



REPORT OF APOLLO 13 REVIEW BOARD

APPENDIX A BASELINE DATA: APOLLO 13 FLIGHT SYSTEMS AND OPERATIONS

NATIONAL AERONAUTICS AND SPACE ADMINISTRATION

1

2

3

4

5

6

7

CONTENTS

Part		Page
	APPENDIX A - BASELINE DATA: APOLLO 13 FLIGHT SYSTEMS AND OPERATIONS	A-1
A1	<u>APOLLO SPACECRAFT CONFIGURATION</u>	A-3
	LAUNCH ESCAPE ASSEMBLY	A-3
	COMMAND MODULE	A-3
	SERVICE MODULE	A-8
	SPACECRAFT LM ADAPTER	A-9
A2	<u>SYSTEMS DESCRIPTION DATA</u>	A-11
	INTRODUCTION	A-11
A2.1	GUIDANCE AND CONTROL	A-12
	Guidance and Control Systems Interface	A-12
	Attitude Reference	A-12
	Attitude Control	A-14
	Thrust and Thrust Vector Control	A-16
A2.2	GUIDANCE AND NAVIGATION SYSTEM (G&N)	A-18
A2.3	STABILIZATION AND CONTROL SYSTEM (SCS)	A-20
A2.4	SERVICE PROPULSION SYSTEM (SPS)	A-22
A2.5	REACTION CONTROL SYSTEM (RCS).	A-24
	SM RCS Functional Description	A-24
	CM RCS Functional Description	A-26
A2.6	<u>ELECTRICAL POWER SYSTEM</u>	A-28
	Introduction	A-28

Part		Page
	Functional Description	A-30
	Major Component/Subsystem Description	A-32
	Performance and Design Data	A-66
	Operational Limitations and Restrictions	A-67
	Systems Test Meter	A-70
	Command Module Interior Lighting	A-72
A2.7	ENVIRONMENTAL CONTROL SYSTEM	A-81
	Introduction	A-81
	Functional Description	A-83
	Oxygen Subsystem	A-86
A2.8	TELECOMMUNICATIONS SYSTEM	A-88
	Introduction	A-88
	Functional Description	A-89
A2.9	SEQUENTIAL SYSTEMS	A-90
	Introduction	A-90
	Sequential Events Control Subsystem	A-90
	Origin of Signals	A-92
A2.10	CAUTION AND WARNING SYSTEM	A-93
	Introduction	A-93
	Functional Description	A-93
	Major Component Subsystem Description	A-93
	Operational Limitations and Restrictions	A-97

Part		Page
A2.11	MISCELLANEOUS SYSTEMS DATA	A-99
	Introduction	A-99
	Timers	A-99
	Accelerometer (G-meter)	A-99
	Command Module Uprighting System	A-99
A2.12	CREW PERSONAL EQUIPMENT	A-103
A2.13	DOCKING AND TRANSFER	A-106
	Introduction	A-106
	Functional Description	A-109
A3	<u>LUNAR MODULE SYSTEMS DESCRIPTION</u>	A-111
	INTRODUCTION	A-111
	LM CONFIGURATION	A-111
	Ascent Stage	A-114
	Descent Stage	A-119
	LM - SLA - S-IVB Connections	A-119
	LM-C&M Interfaces	A-119
	Stowage Provisions	A-122
A4	<u>MISSION CONTROL CENTER ACTIVITIES</u>	A-123
	INTRODUCTION	A-123
	MISSION OPERATIONS CONTROL ROOM	A-128
	MCC SUPPORT ROOMS	A-131
	MISSION SUPPORT AREAS	A-133
	Communications, Command, and Telemetry System (CCATS)	A-133

Part		Page
	Real-Time Computer Complex (RTCC)	A-134
A5	<u>EXCERPTS FROM APOLLO FUEL CELL AND CRYOGENIC GAS</u> <u>STORAGE SYSTEM FLIGHT SUPPORT HANDBOOK</u>	A-139

BASELINE DATA: APOLLO 13 FLIGHT

SYSTEMS AND OPERATIONS

Appendix A is divided into five parts. Part A1 briefly describes the Apollo spacecraft configuration; Part A2 provides a systems description of the Apollo spacecraft configuration with special emphasis on the electrical power system (EPS); Part A3 describes the lunar module systems; Part A4 briefly describes the Mission Control Center at Houston, Texas, and its interface with the spacecraft during the mission; and Part A5 gives a detailed description of the fuel cells and cryogenic gas storage systems aboard the Apollo spacecraft. This baseline material may not always represent the precise Apollo 13 configuration in every case, since there is a continuous updating which is documented periodically. For example, Fuel Cell 2 on Apollo 13 was normally connected to bus A in the distribution system, rather than as described in Part A2.6.

The data were extracted from the following sources:

APPENDIX A

- | | |
|-------------------|---|
| PART A1
and A2 | Technical Manual SM2A-03-Block II-(1)
Apollo Operations Handbook Block II Spacecraft,
Volume 1, dated January 15, 1970. |
| PART A3 | Technical Manual LMA790-3-IM, Apollo Operations
Handbook, Lunar Module, Volume 1, dated February 1,
1970. |
| PART A4 | Manned Spacecraft Center Flight Operations Plan -
H Missions, dated August 31, 1969. |
| PART A5 | Apollo Fuel Cell and Cryogenic Gas Storage System
Flight Support Handbook, dated February 18, 1970,
prepared by Propulsion and Power Division, Manned
Spacecraft Center. |

This page left blank intentionally.

PART A1

APOLLO SPACECRAFT CONFIGURATION

The Apollo spacecraft consists of a launch escape assembly (LEA), command module (CM), service module (SM), the spacecraft lunar module adapter (SLA), and the lunar module (LM). The reference system and stations are shown in figure A1-1.

LAUNCH ESCAPE ASSEMBLY

The LEA (fig. A1-2) provides the means for separating the CM from the launch vehicle during pad or first-stage booster operation. This assembly consists of a Q-ball instrumentation assembly (nose cone), ballast compartment, canard surfaces, pitch control motor, tower jettison motor, launch escape motor, a structural skirt, an open-frame tower, and a boost protective cover (BPC). The structural skirt at the base of the housing, which encloses the launch escape rocket motors, is secured to the forward portion of the tower. The BPC (fig. A1-3) is attached to the aft end of the tower to protect the CM from heat during boost, and from exhaust damage by the launch escape and tower jettison motors. Explosive nuts, one in each tower leg well, secure the tower to the CM structure.

COMMAND MODULE

The CM (fig. A1-4), the spacecraft control center, contains necessary automatic and manual equipment to control and monitor the spacecraft systems; it also contains the required equipment for safety and comfort of the flight crew. The module is an irregular-shaped, primary structure encompassed by three heat shields (coated with ablative material and joined or fastened to the primary structure) forming a truncated, conic structure. The CM consists of a forward compartment, a crew compartment, and an aft compartment for equipment. (See fig. A1-4.)

The command module is conical shaped, 11 feet 1.5 inches long, and 12 feet 6.5 inches in diameter without the ablative material. The ablative material is nonsymmetrical and adds approximately 4 inches to the height and 5 inches to the diameter.

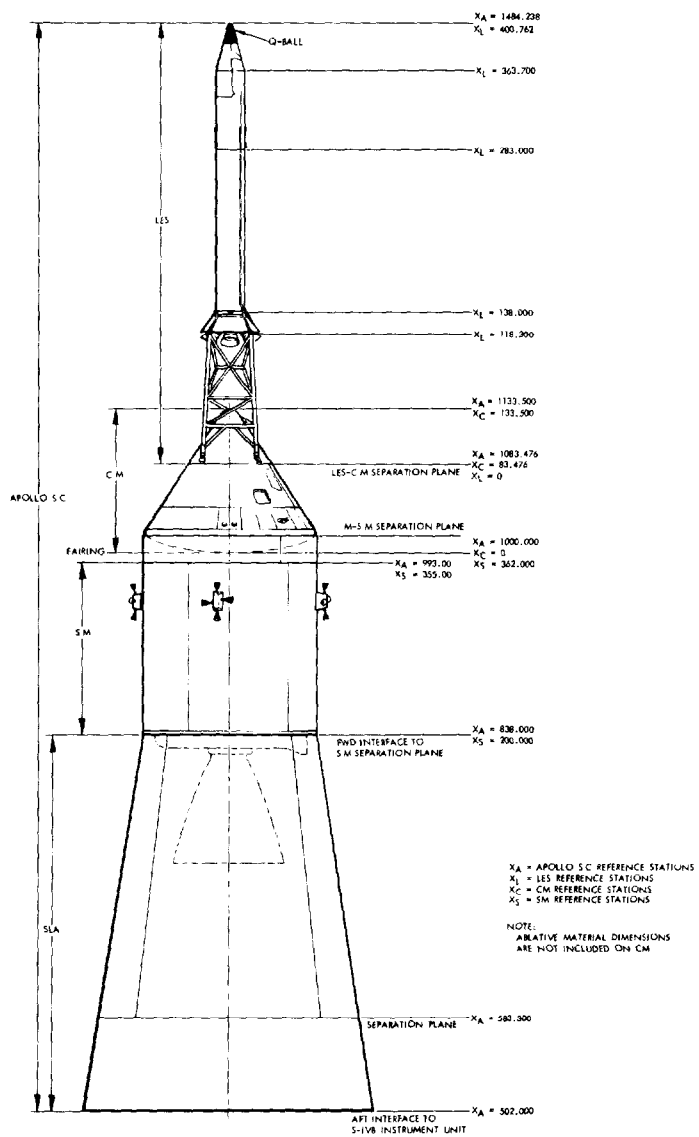

Figure A1-1.- Block II spacecraft reference stations.

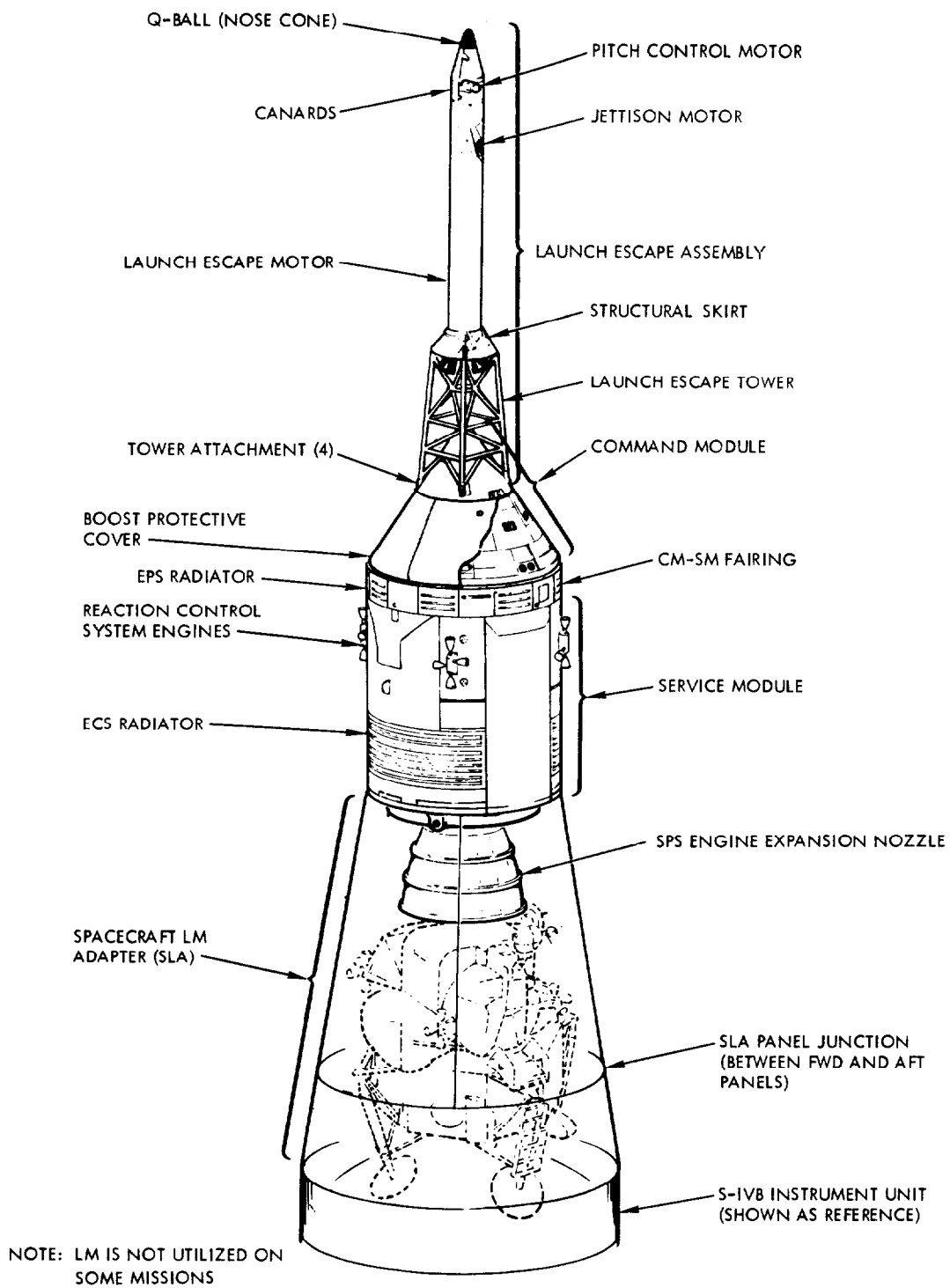
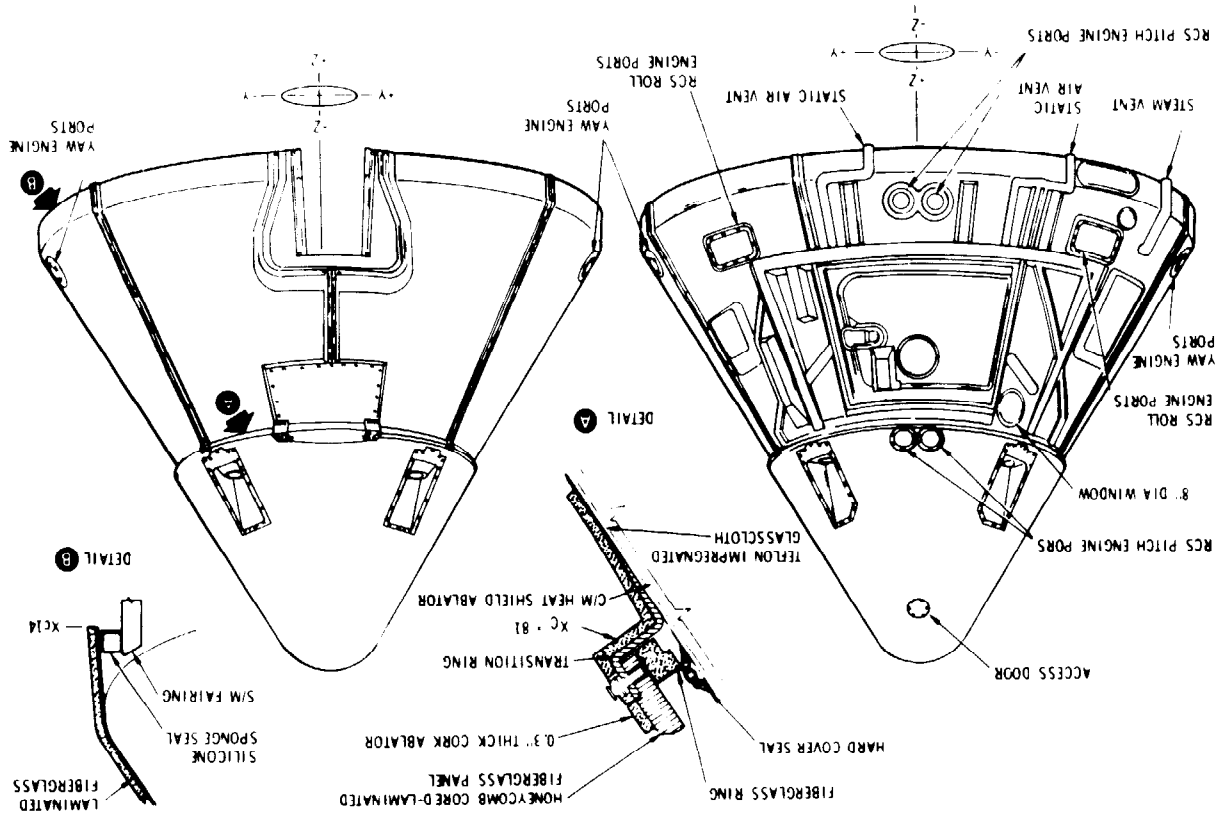

Figure A1-2.- Block II spacecraft configuration.

Figure A1-3.- Boost protective cover.



COMMAND MODULE

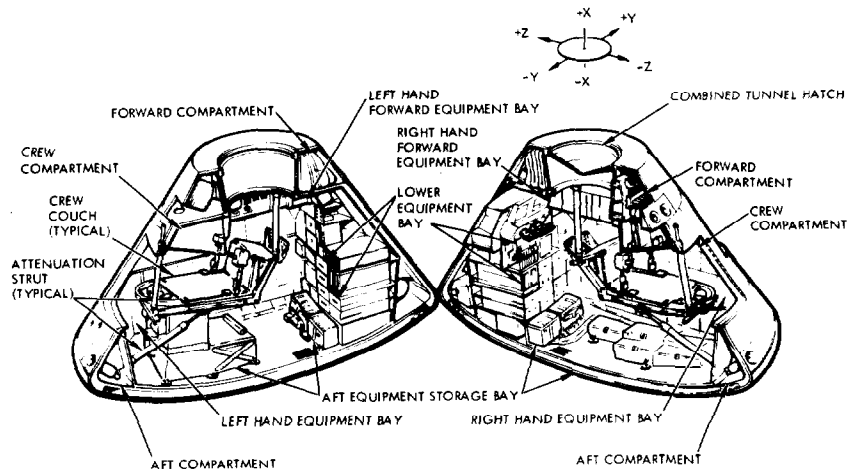
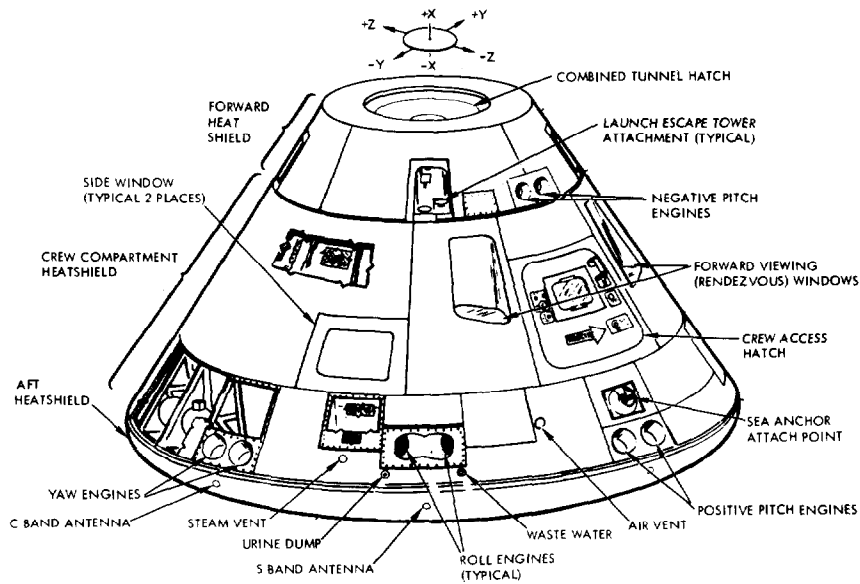

Figure A1-4.- Block II command module.

SERVICE MODULE

The service module (fig. A1-5) is a cylindrical structure formed by 1-inch-thick aluminum honeycomb panels. Radial beams, from milled aluminum alloy plates, separate the structure interior into six unequal sectors around a circular center section. Equipment contained within

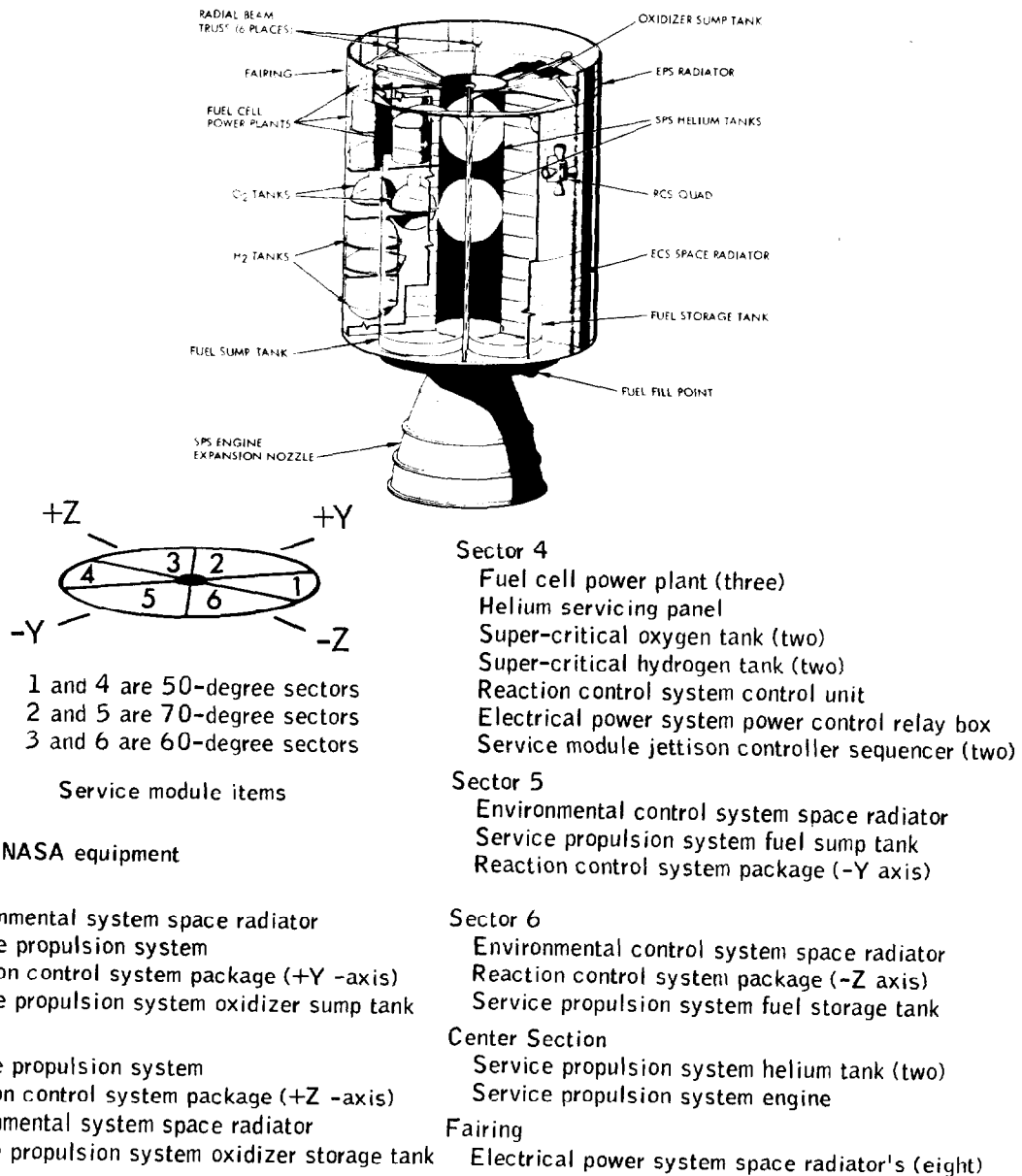

Figure A1-5.- Service module.

the service module is accessible through maintenance doors located around the exterior surface of the module. Specific items, such as propulsion systems (SPS and RCS), fuel cells, and most of the SC onboard consumables (and storage tanks) contained in the SM compartments, are listed in figure A1-5. The service module is 12 feet 11 inches long (high) and 12 feet 10 inches in diameter.

Radial beam trusses on the forward portion of the SM structure provide a means for securing the CM to the SM. Alternate beams one, three, and five have compression pads for supporting the CM. Beams two, four, and six have shear-compression pads and tension ties. A flat center section in each tension tie incorporates redundant explosive charges for SM-CM separation. These beams and separation devices are enclosed within a fairing (26 inches high and 13 feet in diameter) between the CM and SM.

SPACECRAFT LM ADAPTER

The spacecraft LM adapter (SLA) (fig. A1-6) is a large truncated cone which connects the CSM and S-IVB on the launch vehicle. It houses the lunar module (LM), the nozzle of the service propulsion system, and the high-gain antenna in the stowed position. The adapter, constructed of eight 2-inch-thick aluminum panels, is 154 inches in diameter at the forward end (CM interface) and 260 inches at the aft end. Separation of the CSM from the SLA is accomplished by means of explosive charges which disengage the four SLA forward panels from the aft portion. The individual panels are restrained to the aft SLA by hinges and accelerated in rotation by pyrotechnic-actuated thrusters. When reaching an angle of 45 degrees measured from the vehicle's X-axis, spring thrusters (two per panel) jettison the panels. The panel jettison velocity and direction of travel is such as to minimize the possibility of recontact with the spacecraft or launch vehicle.

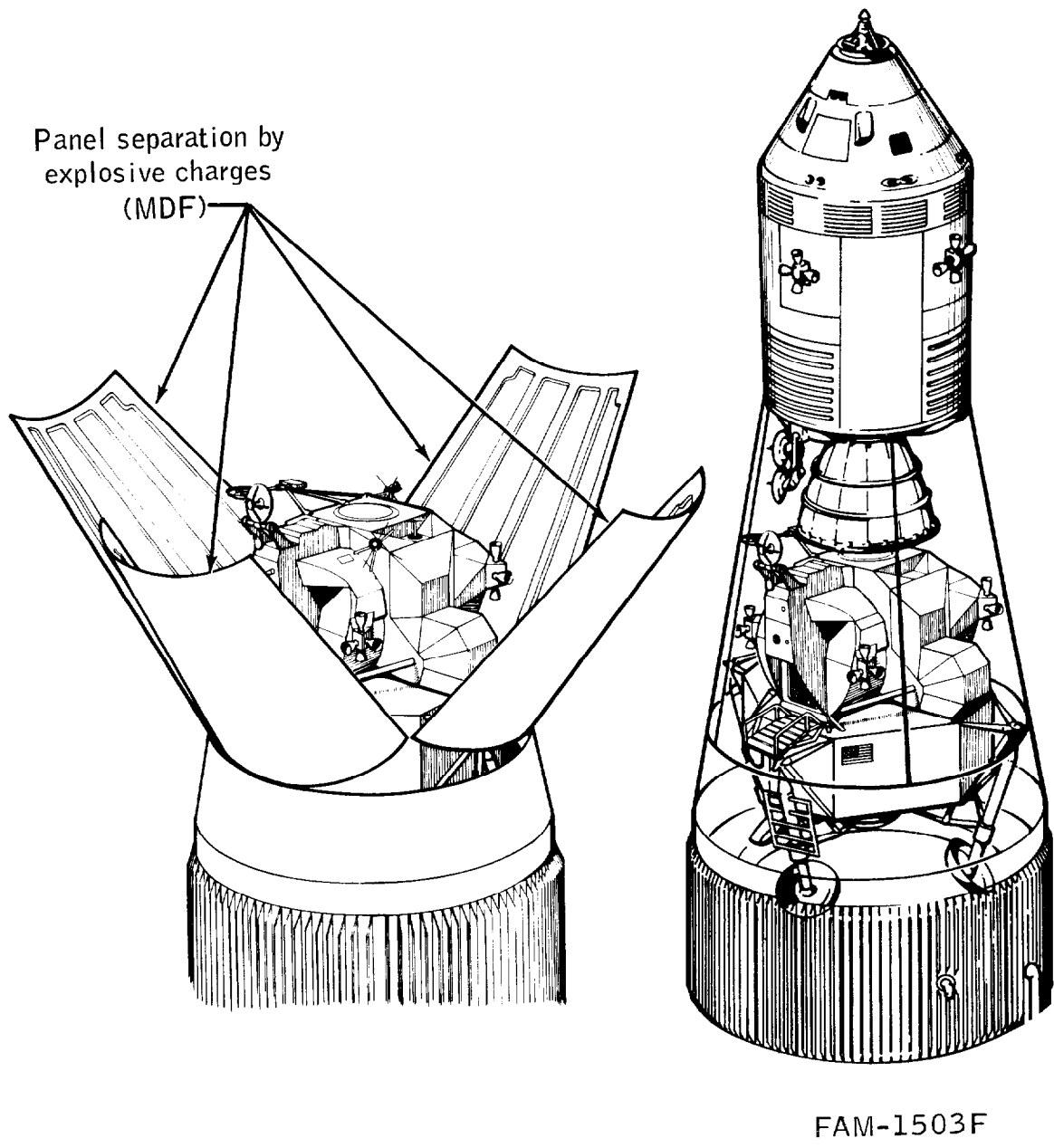

Figure A1-6.- Spacecraft LM adapter.

PART A2

SYSTEMS DESCRIPTION DATA

INTRODUCTION

Systems description data include description of operations, component description and design data, and operational limitations and restrictions. Part 2.1 describes the overall spacecraft navigation, guidance, and control requirements and the resultant systems interface. Parts A2.2 through A2.10 present data grouped by spacecraft systems, arranged in the following order: guidance and navigation, stabilization and control, service propulsion, reaction control, electrical power, environmental control, telecommunications, sequential, and caution and warnings. Part A2.11 deals with miscellaneous systems data. Part A2.12 deals with crew personal equipment. Part A2.13 deals with docking and crew transfer.

These data were extracted from the technical manual SM2A-03-BLOCK II-(1), Apollo Operations Handbook, Block II Spacecraft, Volume 1, dated January 15, 1970.

PART A2.1

GUIDANCE AND CONTROL

Guidance and Control Systems Interface

The Apollo guidance and control functions are performed by the primary guidance, navigation, and control system (PGNCS), and stabilization and control system (SCS). The PGNCS and SCS systems contain rotational and translational attitude and rate sensors which provide discrete input information to control electronics which, in turn, integrate and condition the information into control commands to the spacecraft propulsion systems. Spacecraft attitude control is provided by commands to the reaction control system (RCS). Major velocity changes are provided by commands to the service propulsion system (SPS). Guidance and control provides the following basic functions:

- a. Attitude reference
- b. Attitude control
- c. Thrust and thrust vector control.

The basic guidance and control functions may be performed automatically, with primary control furnished by the command module computer (CMC) or manually, with primary control furnished by the flight crew. The subsequent paragraphs provide a general description of the basic functions.

Attitude Reference

The attitude reference function (fig. A2.1-1) provides display of the spacecraft attitude with reference to an established inertial reference. The display is provided by two flight director attitude indicators (FDAI) located on the main display console, panels 1 and 2. The displayed information consists of total attitude, attitude errors, and angular rates. The total attitude is displayed by the FDAI ball. Attitude errors are displayed by three needles across scales on the top, right, and bottom of the apparent periphery of the ball. Angular rates are displayed by needles across the top right, and bottom of the FDAI face.

Total attitude information is derived from the IMU stable platform or the gyro display coupler (GDC). The IMU provides total attitude by maintaining a gimballed, gyro-stabilized platform to an inertial reference orientation. The GDC provides total attitude by updating attitude information with angular rate inputs from gyro assembly 1 or 2.

A-13

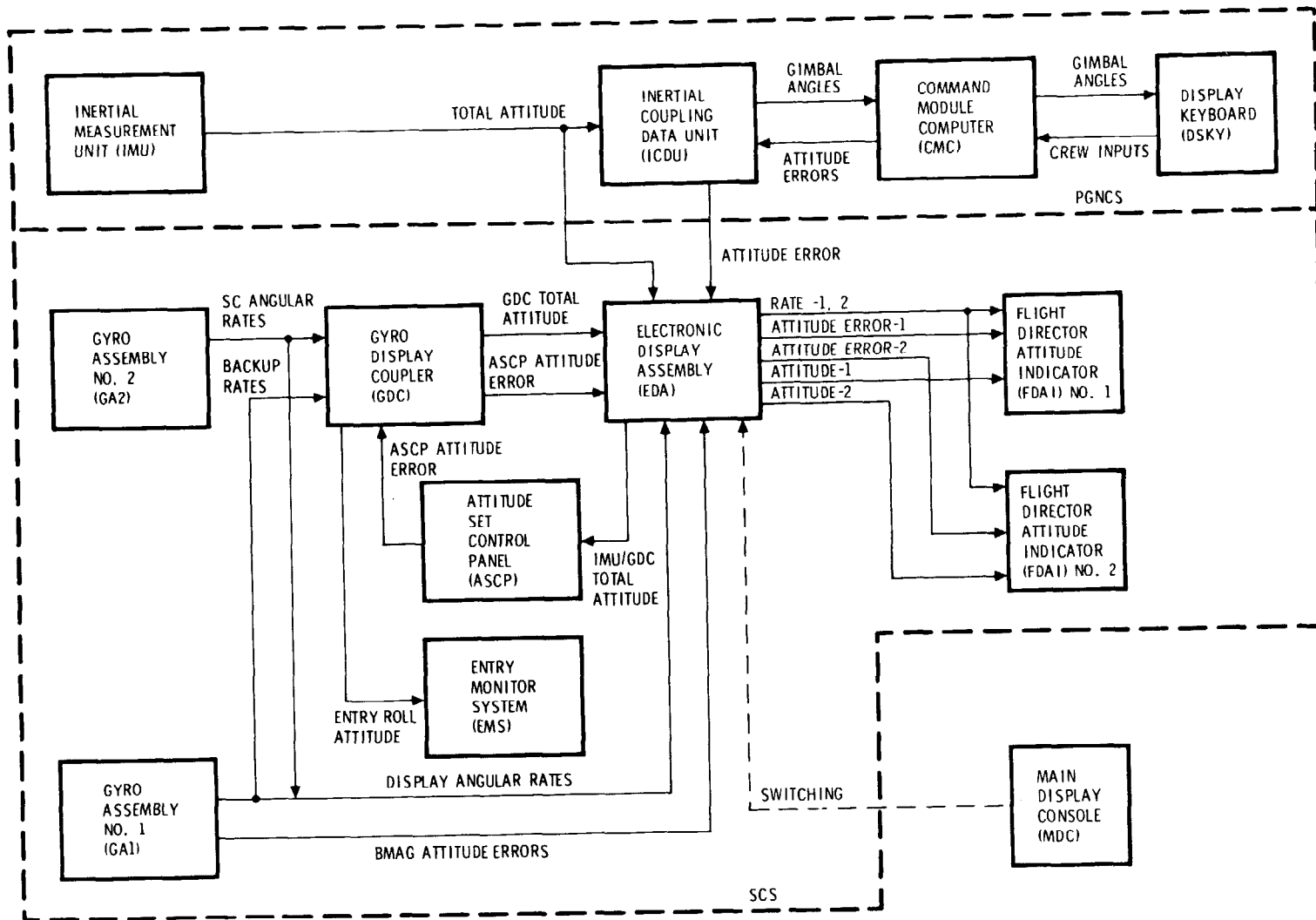

Figure A2.1-1.- Guidance and control.

Attitude error information is derived from three sources. The first source is from the IMU through the coupling data unit (CDU) which compares IMU gimbal angles with CMC commanded angles set into the CDU. Any angular difference between the IMU gimbals and the CDU angles is sent to the FDAI for display on the attitude error needles. The second source is from gyro assembly 1 which contains three (one for each of the X, Y, and Z axes) single-degree-of-freedom attitude gyros. Any spacecraft rotation about an axis will offset the case of a gyro from the float. This rotation is sensed as a displacement off null, and a signal is picked off which is representative of the magnitude and direction of rotation. This signal is sent to the FDAI for display on the attitude error needles. The third source is from the GDC which develops attitude errors by comparing angular rate inputs from gyro assembly 1 or 2 with an internally stored orientation. These data are sent to the FDAI for display on the attitude error needles.

Angular rates are derived from either gyro assembly 1 or 2. Normally, the no. 2 assembly is used; however, gyro assembly 1 may be switched to a backup rate mode if desired. For developing rate information, the gyros are torqued to null when displaced; thus, they will produce an output only when the spacecraft is being rotated. The output signals are sent to the FDAI for display on the rate needles and to the GDC to enable updating of the spacecraft attitude.

Attitude Control

The attitude control function is illustrated in figure A2.1-2. The control may be to maintain a specific orientation, or to command small rotations or translations. To maintain a specific orientation, the attitude error signals, described in the preceding paragraph, are also routed to the control reaction jet on-off assembly. These signals are conditioned and applied to the proper reaction jet which fires in the direction necessary to return the spacecraft to the desired attitude. The attitude is maintained within specified deadband limits. The deadband is limited within both a rate and attitude limit to hold the spacecraft excursions from exceeding either an attitude limit or angular rate limit. To maneuver the spacecraft, the reaction jets are fired automatically under command of the CMC or manually by flight crew use of the rotation control. In either case, the attitude control function is inhibited until the maneuver is completed. Translations of small magnitude are performed along the +X axis for fuel settling of SPS propellants prior to burns, or for a backup deorbit by manual commands of the translation control. An additional control is afforded by enabling the minimum impulse control at the lower equipment bay. The minimum impulse control produces one directional pulse of small magnitude each time it is moved from detent. These small pulses are used to position the spacecraft for navigational sightings.

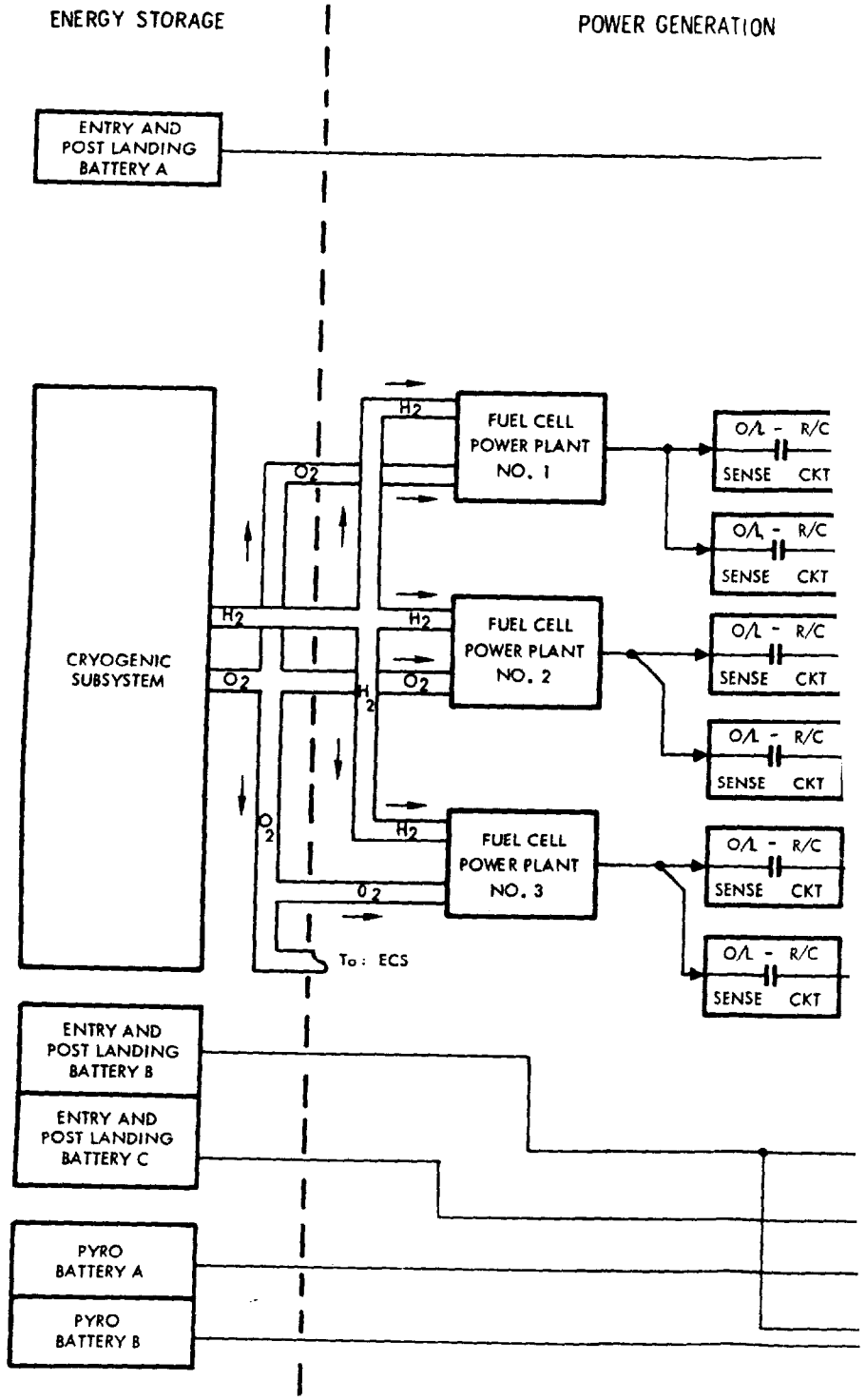

GENERATION

POWER CONVERSION

POWER DISTRIBUTION

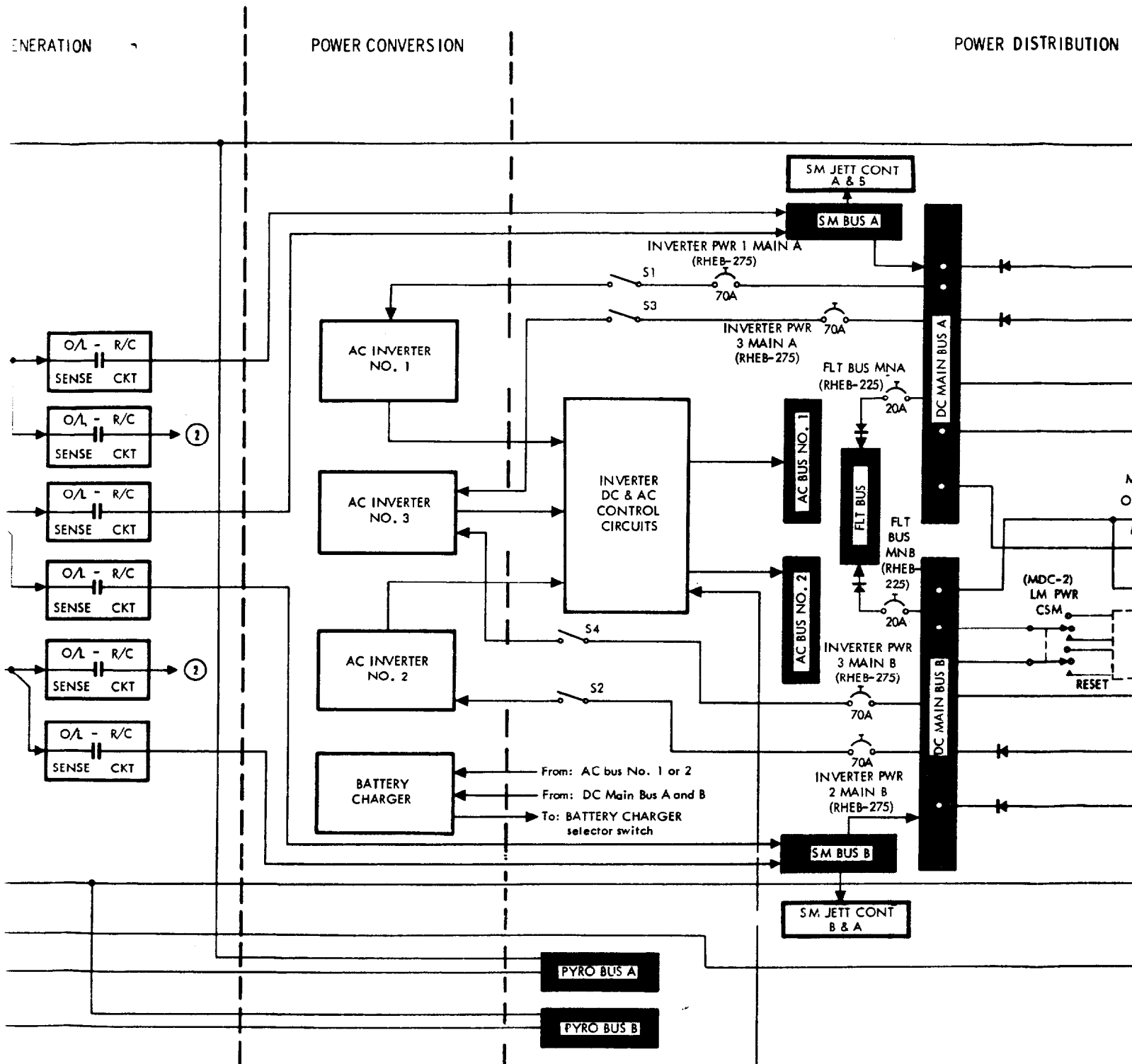

POWER DISTRIBUTION

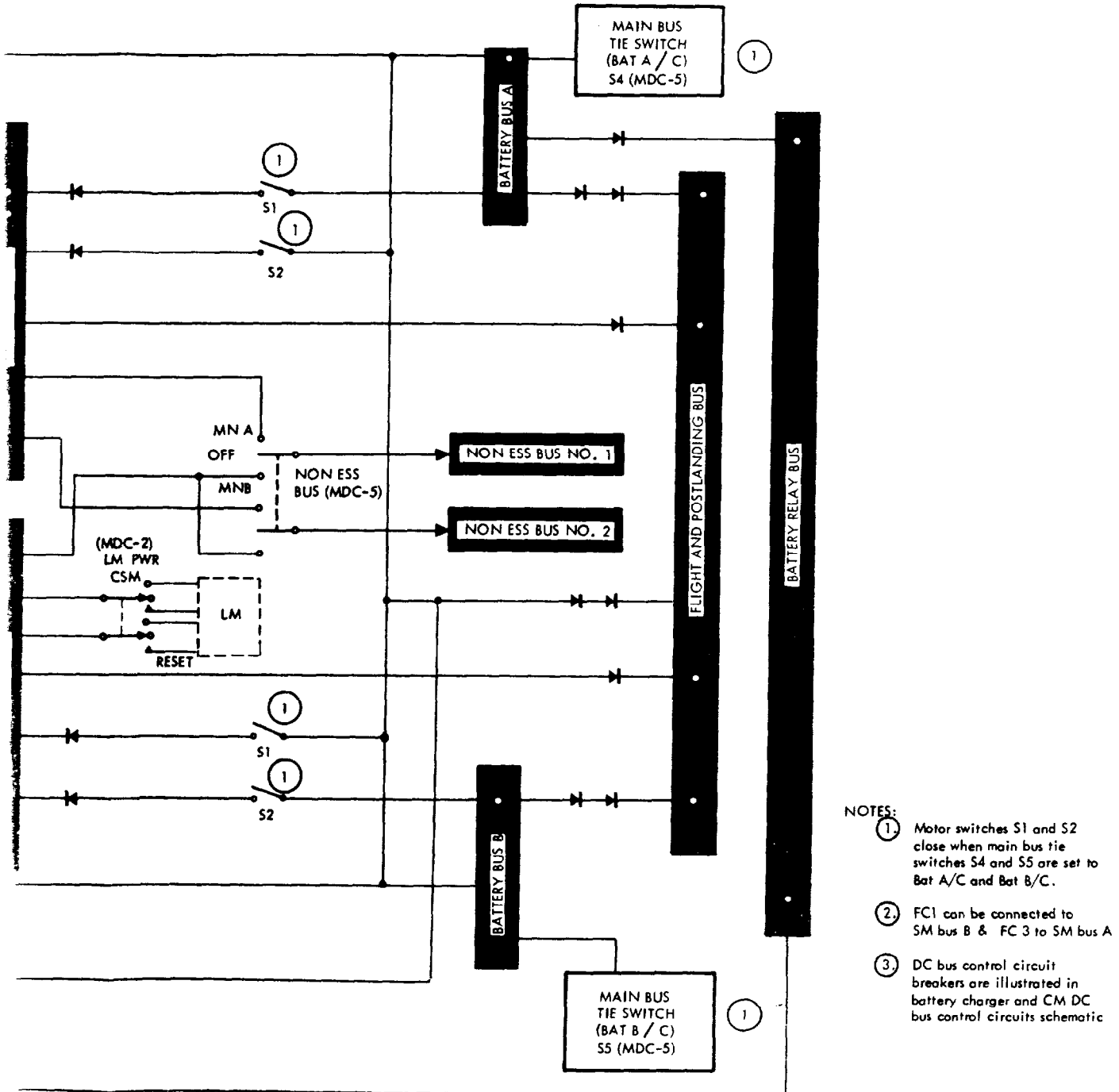

- NOTES:
- ① Motor switches S1 and S2 close when main bus tie switches S4 and S5 are set to Bat A/C and Bat B/C.
 - ② FC1 can be connected to SM bus B & FC 3 to SM bus A
 - ③ DC bus control circuit breakers are illustrated in battery charger and CM DC bus control circuits schematic

Figure A2.6-1.- Electrical power subsystem block diagram.

Functional Description

Energy storage.- The primary source of energy is the cryogenic gas storage system that provides fuel (H_2) and oxidizer (O_2) to the power generating system. Two hydrogen and two oxygen tanks, with the associated controls and plumbing, are located in the service module. Storage of reactants is accomplished under controlled cryogenic temperatures and pressures; automatic and manual pressure control is provided. Automatic heating of the reactants for repressurization is dependent on energy demand by the power generating and/or environmental control subsystems. Manual control can be used when required.

A secondary source of energy storage is provided by five silver oxide-zinc batteries located in the CM. Three rechargeable entry and postlanding batteries supply sequencer logic power at all times, supplemental dc power for peak loads, all operating power required for entry and postlanding, and can be connected to power either or both pyro circuits. Two pyro batteries provide energy for activation of pyro devices throughout all phases of a mission.

Power generation.- Three Bacon-type fuel cell power plants, generating power through electrochemical reaction of H_2 and O_2 , supply primary dc power to spacecraft systems until CSM separation. Each power plant is capable of normally supplying from 400 to 1420 watts at 31 to 27 V dc (at fuel cell terminals) to the power distribution system. During normal operation all three power plants generate power, but two are adequate to complete the mission. Should two of the three malfunction, one power plant will insure successful mission termination; however, spacecraft loads must be reduced to operate within the limits of a single power-plant.

Normal fuel cell connection to the distribution system is: fuel cell 1 to main dc bus A; fuel cell 2 to main dc busses A and B; and fuel cell 3 to main dc bus B. Manual switch control is provided for power plant connection to the distribution system, and manual and/or automatic control for power plant isolation in case of a malfunction.

During the CSM separation maneuver, the power plants supply power through the SM buses to two SM jettison control sequencers. The sequencers sustain SM RCS retrofire during CSM separation and fire the SM positive roll RCS engines 2 seconds after separation to stabilize the SM during entry. Roll engine firing is terminated 7.5 seconds after separation. The power plants and SM buses are isolated from the umbilical through a SM deadface. The sequencers are connected to the SM buses when the CM/SM SEP switch (MDC-2) is activated; separation occurs 100 milliseconds after switch activation.

Power conversion.- Primary dc power is converted into ac by solid state static inverters that provide 115/200-volt 400-cps 3-phase ac power up to 1250 volt-amperes each. The ac power is connected by motor switch controls to two ac buses for distribution to the ac loads. One inverter has the capability of supplying all spacecraft primary ac power. One inverter can power both buses while the two remaining inverters act as redundant sources. However, throughout the flight, each bus is powered by a separate inverter. Provisions are made for inverter isolation in the event of malfunctions. Inverter outputs cannot be phase synchronized; therefore, interlocked motorized switching circuits are incorporated to prevent the connection of two inverters to the same bus.

A second conversion unit, the battery charger, assures keeping the three entry and postlanding batteries in a fully charged state. It is a solid state device utilizing dc from the fuel cells and ac from the inverter to develop charging voltage.

Power distribution.- Distribution of dc power is accomplished via two redundant dc buses in the service module which are connected to two redundant buses in the command module through a SM deadface, the CSM umbilical, and a CM deadface. Additional buses provided are: two dc buses for servicing nonessential loads; a flight bus for servicing in-flight telecommunications equipment; two battery buses for distributing power to sequencers, gimbal motor controls, and servicing the battery relay bus for power distribution switching; and a flight and postlanding bus for servicing some communications equipment and the postlanding loads.

Three-phase ac is distributed via two redundant ac buses, providing bus selection through switches in the ac-operated component circuits.

Power to the lunar module is provided through two umbilicals which are manually connected after completion of transposition and docking. An average of 81 watts dc is provided to continuous heaters in the abort sensor assembly (ASA), and cycling heaters in the landing radar, rendezvous radar, S-band antenna, and inertial measurement unit (IMU). Power consumption with all heaters operating simultaneously is approximately 309 watts. LM floodlighting is also powered through the umbilical for use during manned lunar module operation while docked with the CSM.

A dc sensing circuit monitors voltage on each main dc bus, and an ac sensing circuit monitors voltage on each ac bus. The dc sensors provide an indication of an undervoltage by illuminating a warning light. The ac sensors illuminate a warning light when high- or low-voltage limits are exceeded. In addition, the ac sensors activate an automatic disconnect of the inverter from the ac bus during an overvoltage condition. The ac overload conditions are displayed by illumination of an overload warning light and are accompanied by a low voltage light. Additional

sensors monitor fuel cell overload and reverse current conditions, providing an automatic disconnect, together with visual indications of the disconnect whenever either condition is exceeded.

Switches, meters, lights, and talk-back indicators are provided for controlling and monitoring all functions of the EPS.

Major Component/Subsystem Description

The subsequent paragraphs describe the cryogenic storage subsystem and each of the various EPS components.

Cryogenic storage.- The cryogenic storage subsystem (figs. A2.6-2 and A2.6-3) supplies hydrogen to the EPS, and oxygen to the EPS, ECS, and for initial LM pressurization. The two tanks in the hydrogen and oxygen systems are of sufficient size to provide a safe return from the furthest point of the mission on the fluid remaining in any one tank. The physical data of the cryogenic storage subsystem are as follows:

	Weight of usable cryogenics (lb/tank)	Design storage pressure (psia)	Minimum allowable operating pressure (psia)	Approximate flow rate at min dq/dm (+145° F environment) (lb/hr-2 tanks)	Approximate quantities at minimum heater and fan cycling (per tank) (min dq/dm)
O ₂	320 (min)	900±35	150	1.71	45 to 25%
H ₂	28 (min)	245 (+15, -20)	100	0.140	53 to 33%

Initial pressurization from fill to operating pressures is accomplished by GSE. After attaining operating pressures, the cryogenic fluids are in a single-phase condition, therefore, completely homogeneous. This avoids sloshing which could cause sudden pressure fluctuations, possible damage to internal components, and prevents positive mass quantity gauging. The single-phase expulsion process continues at nearly constant pressure and increasing temperature above the 2-phase region.

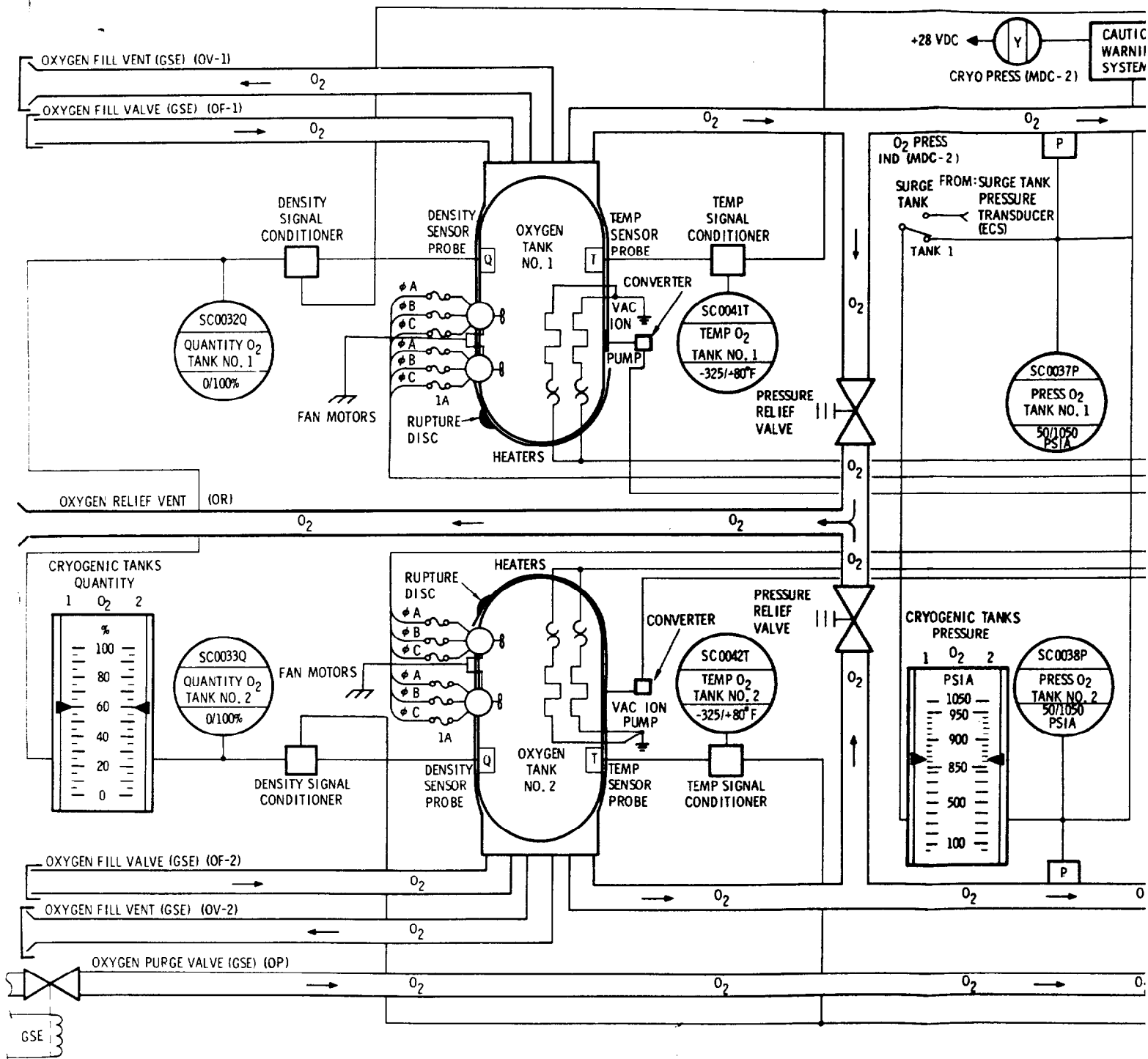
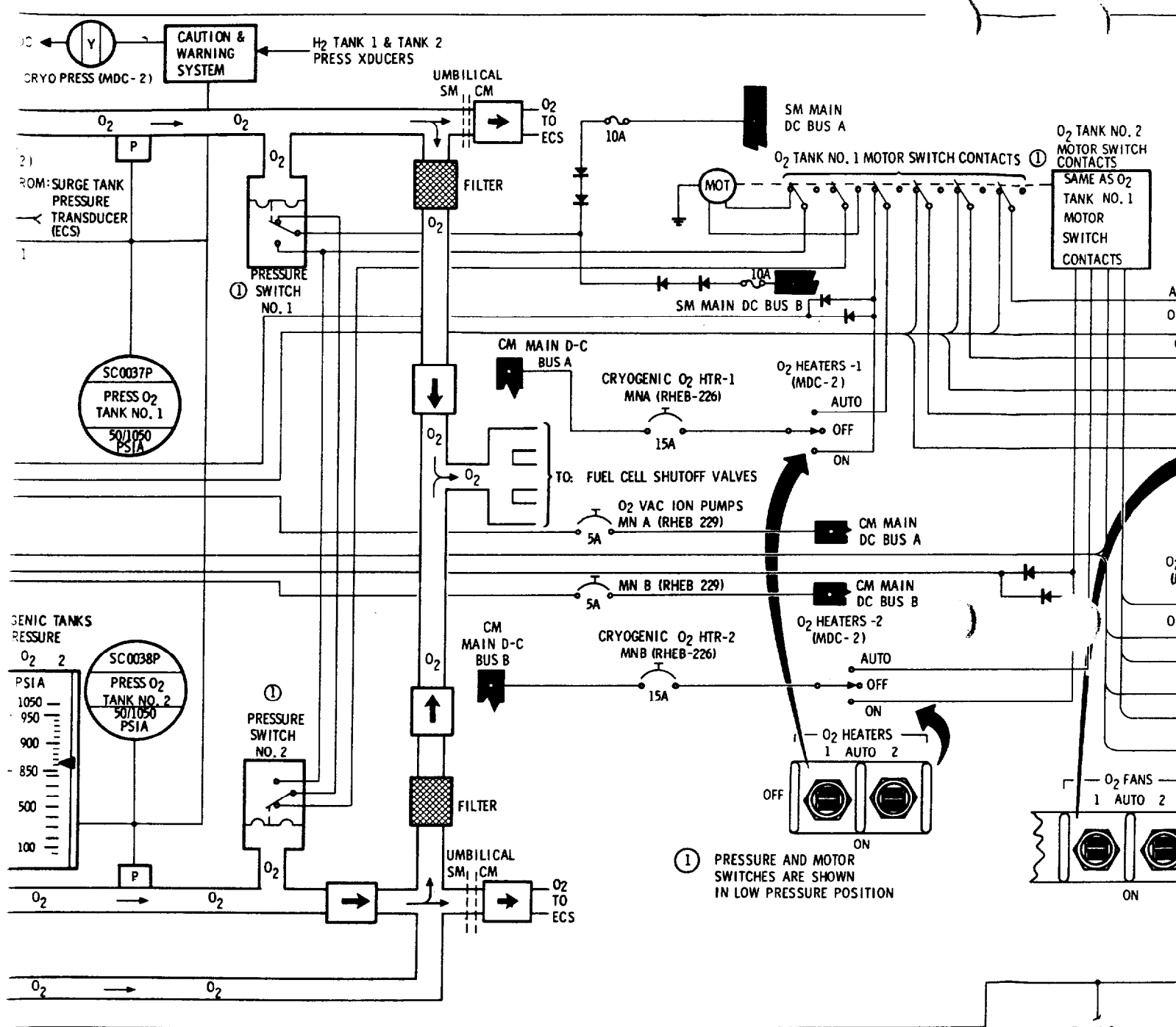
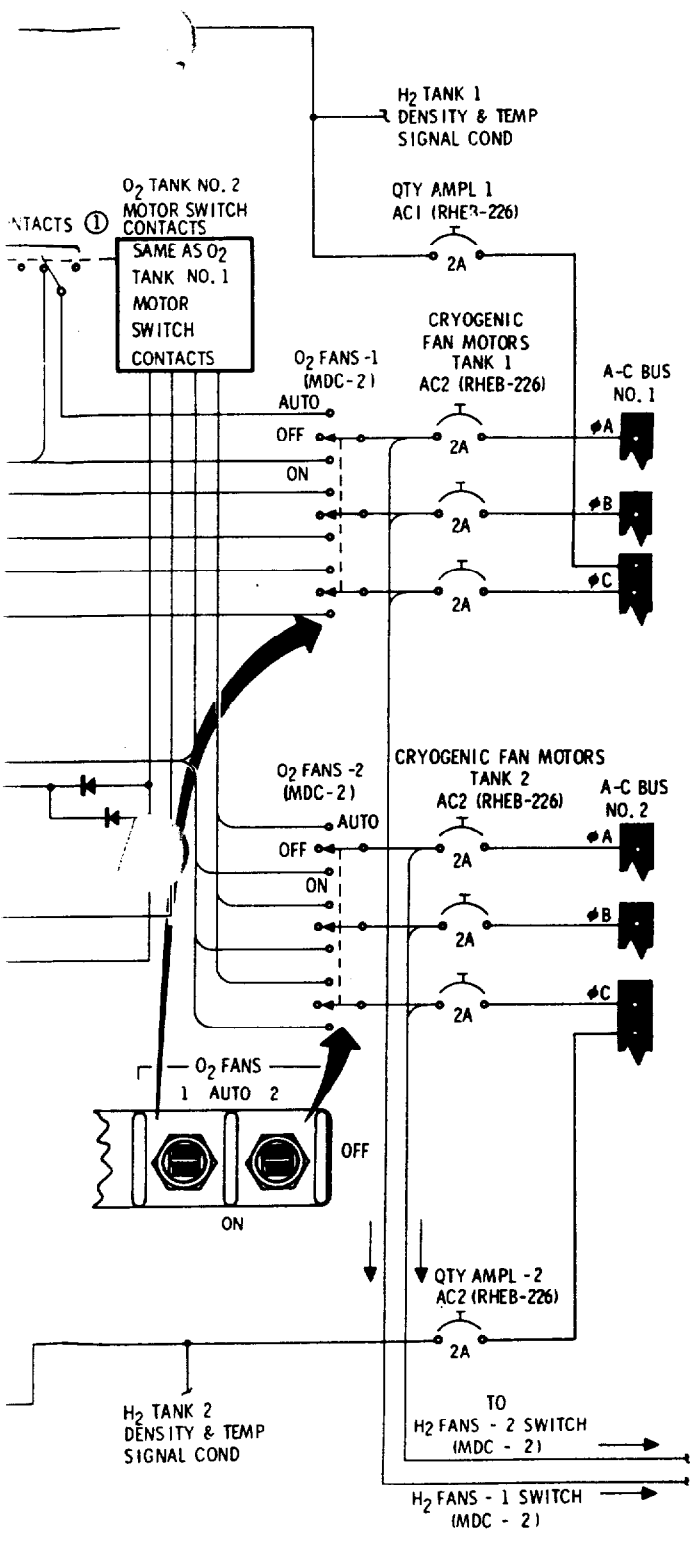
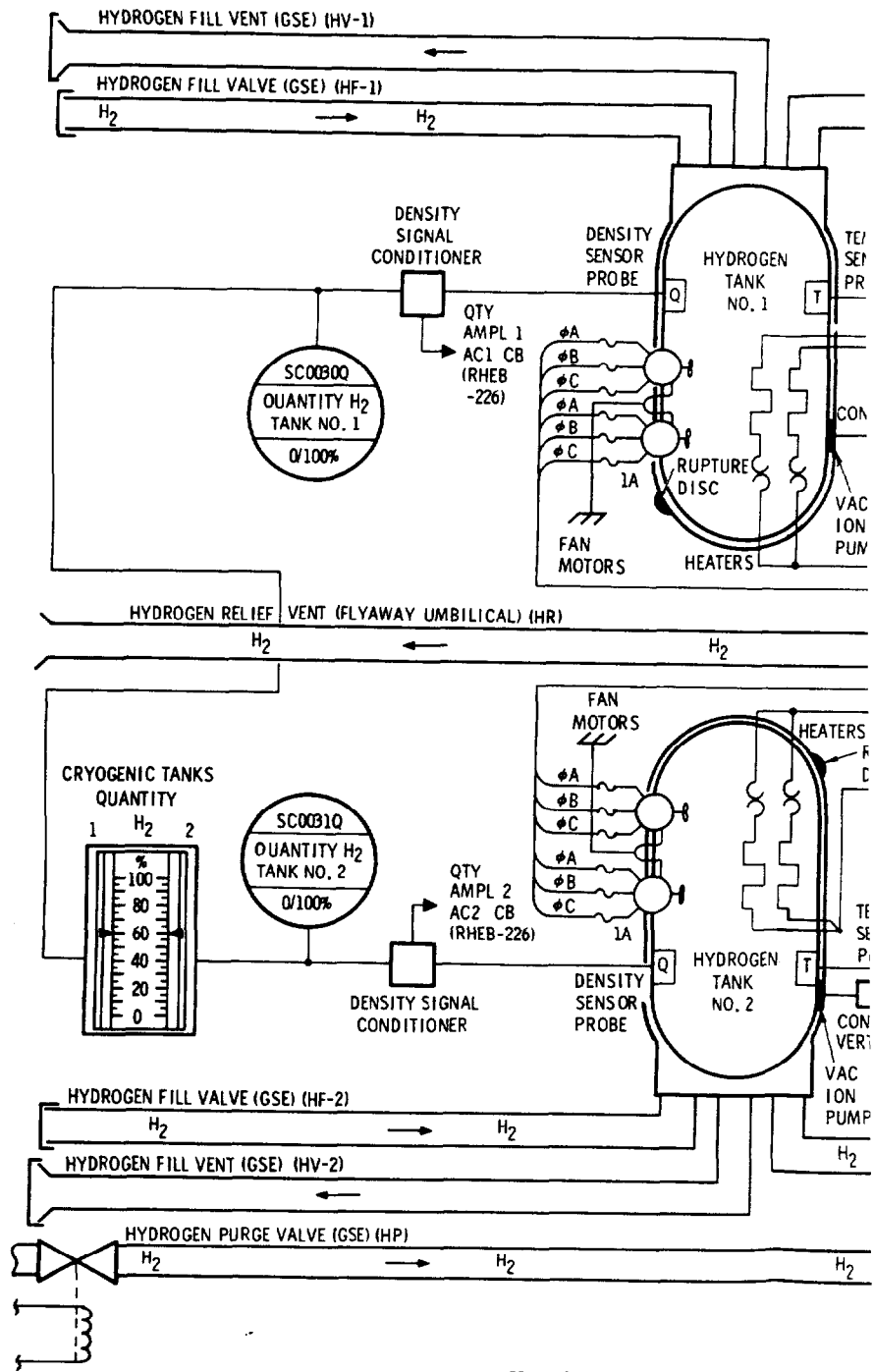
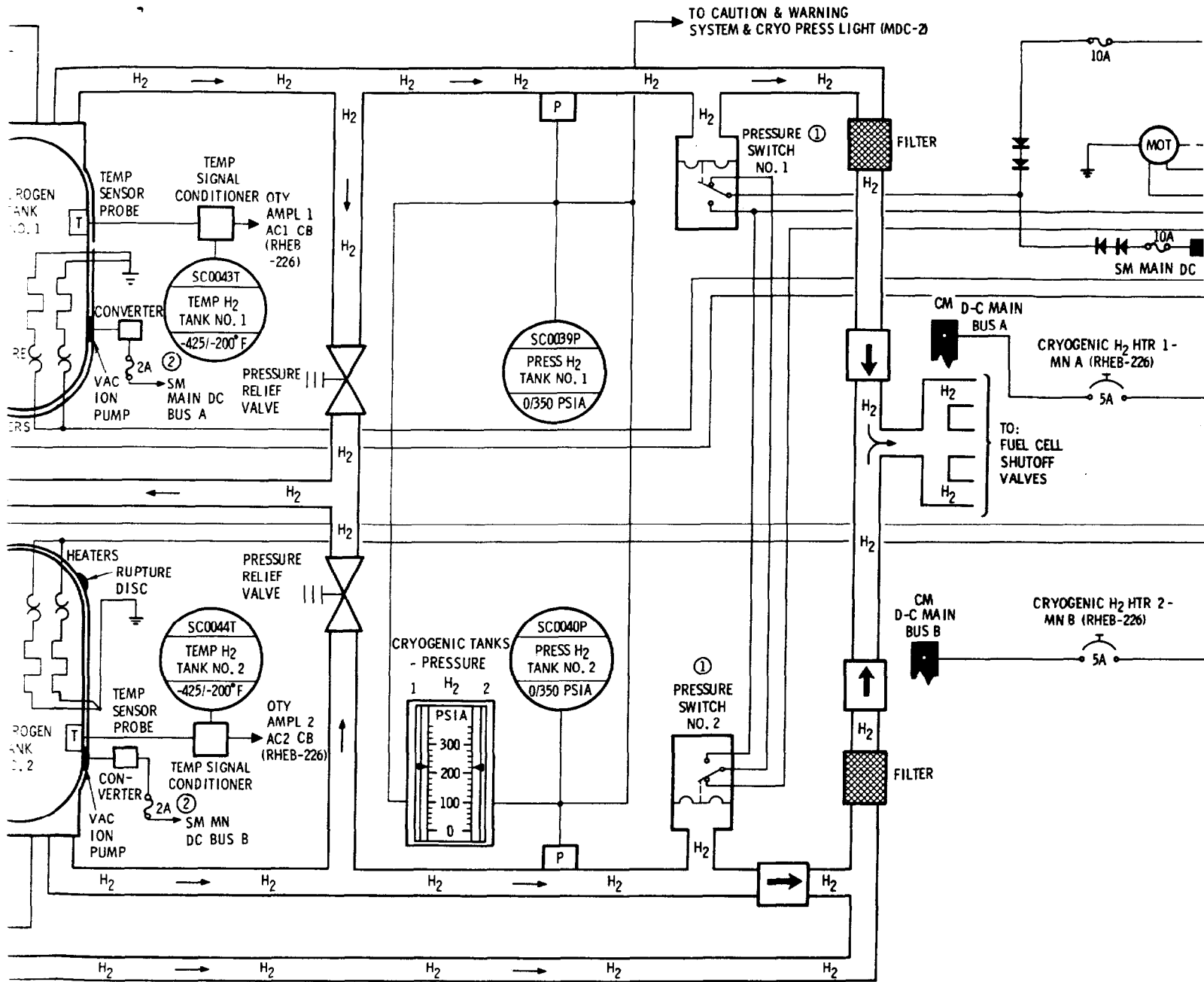

Figure A2.6-2.- Cryogenic storage subsystem (oxygen).









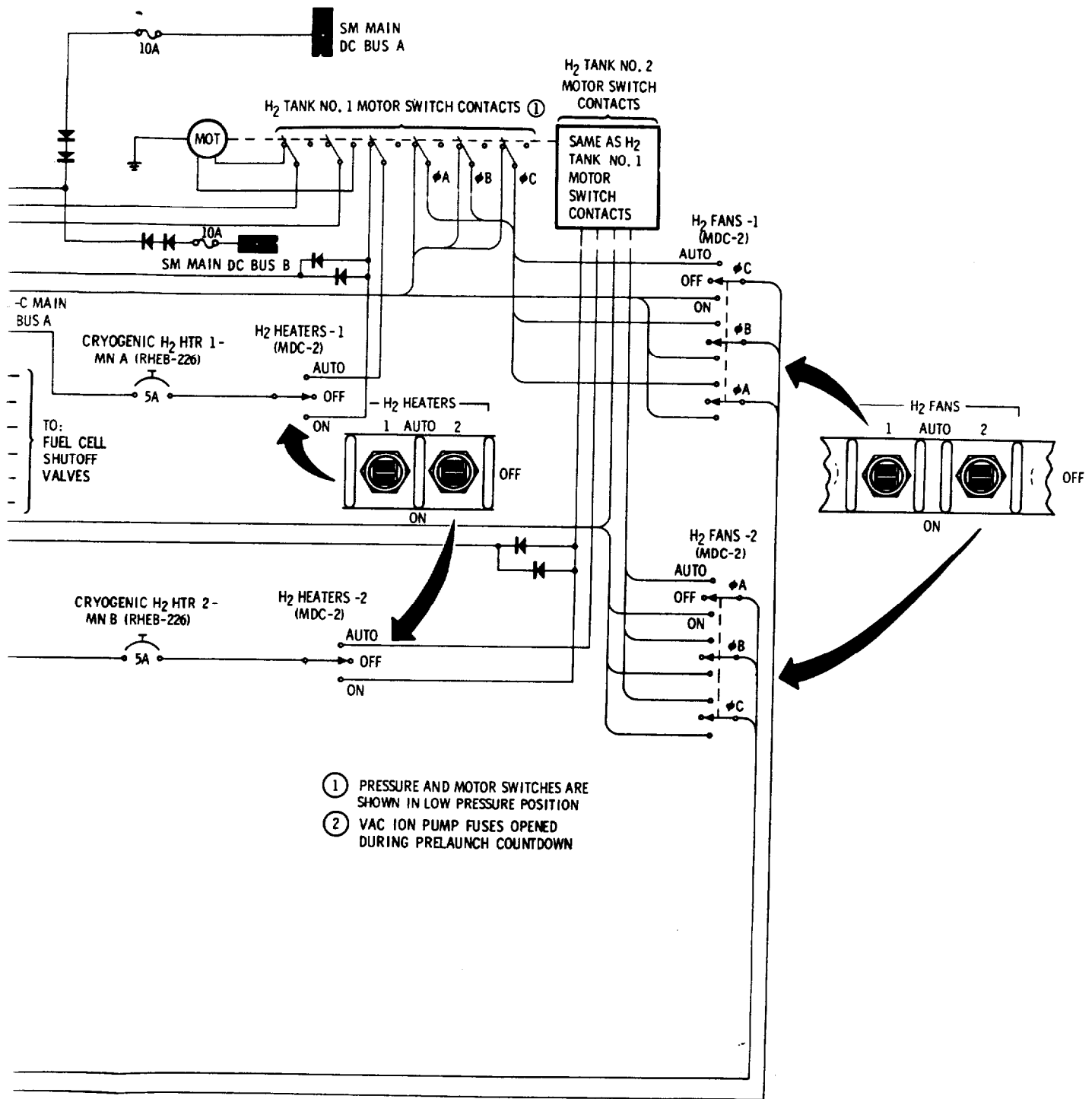

Figure A2.6-3.- Cryogenic storage subsystem (hydrogen)

Two parallel dc heaters in each tank supply the heat necessary to maintain design pressures. Two parallel 3-phase ac circulating fans circulate the fluid over the heating elements to maintain a uniform density and decrease the probability of stratification. A typical heater and fan installation is shown in figure A2.6-4. Relief valves provide overpressure relief, check valves provide tank isolation, and individual fuel cell shutoff valves provide isolation of malfunctioning power plants. Filters extract particles from the flowing fluid to protect the ECS and EPS components. The pressure transducers and temperature probes indicate the thermodynamic state of the fluid. A capacitive quantity probe indicates quantity of fluid remaining in the tanks.

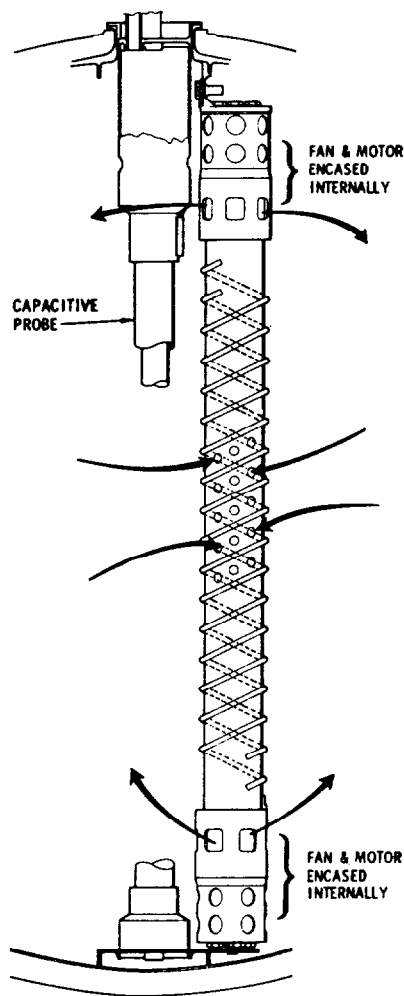

Figure A2.6-4.- Cryogenic pressurization and quantity measurement devices.

Repressurization of the systems can be automatically or manually controlled by switch selection. The automatic mode is designed to give a single-phase reactant flow into the feed lines at design pressures. The heaters and fans are automatically controlled through a pressure switch-motor switch arrangement. As pressure in the tanks decreases, the pressure switch in each tank closes to energize the motor switch, closing contacts in the heater and fan circuits. Both tanks have to decrease in pressure before heater and fan circuits are energized. When either tank reaches the upper operating pressure limit, that respective pressure switch opens to again energize the motor switch, thus opening the heater and fan circuits to both tanks. The O₂ circuits are energized at 865 psia minimum and de-energized at 935 psia maximum. The H₂ circuits energize at 225 psia minimum and de-energize at 260 psia maximum. The most accurate quantity readout will be acquired shortly after the fans have stopped. During all other periods partial stratification may degrade quantity readout accuracy.

When the systems reach the point where heater and fan cycling is at a minimum (due to a reduced heat requirement), heat leak of the tank is sufficient to maintain design pressures, provided flow is within the min dq/dm values shown in the preceding tabulation. This realm of operation is referred to as the min dq/dm region. The minimum heat requirement region for oxygen starts at approximately 45-percent quantity and terminates at approximately 25-percent quantity. Between these tank quantities, minimum heater and fan cycling will occur under normal usage. The amount of heat required for repressurization at quantities below 25-percent starts to increase until below the 3-percent level practically continuous heater and fan operation is required. In the hydrogen system, the quantity levels for minimum heater and fan cycling are between approximately 53 and 33 percent, with continuous operation occurring at approximately the 5 percent-level.

Assuming a constant level flow from each tank (O₂ - 1 lb/hr, H₂ - 0.09 lb/hr) each successive repressurization period is of longer duration. The periods between repressurizations lengthen as quantity decreases from full to the minimum dq/dm level, and become shorter as quantity decreases from the minimum dq/dm level to the residual level. Approximate repressurization periods are shown in table A2.6-I, which also shows the maximum flow rate in pounds per hour from a single tank with the repressurization circuits maintaining minimum design pressure.

The maximum continuous flow that each cryogenic tank can provide at minimum design pressure is dependent on the quantity level and the heat required to maintain that pressure. The heat required to maintain a constant pressure decreases as quantity decreases from full to the minimum

dq/dm point. As quantity decreases beyond the minimum dq/dm region, the heat required to maintain a constant pressure increases. As fluid is withdrawn, a specific amount of heat is withdrawn. When the withdrawal rate exceeds the heat that can be supplied by the heaters, fan motors, and heat leak, there is a resultant pressure decrease below the minimum design operating level.

The ability to sustain pressure and flow is a factor of the amount of heat required versus the heat provided by heaters, fan motors, and heat leak. Since heat leak characteristics of each tank vary slightly, the flow each tank can provide will also vary to a small degree. Heat input from heaters, fan motors, and heat leak into an O₂ tank is

595.87 Btu/hour (113.88-watt heaters supply 389.67 Btu, 52.8-watt fan motors supply 180.2 Btu, and heat leak supplies 26 Btu). Heat input from similar sources into a H₂ tank is 94.6 Btu/hr (18.6-watt heaters supply

63.48 Btu, 7-watt fan motors supply 23.89 Btu, and heat leak supplies 7.24 Btu). These figures take into consideration the line loss between the power source and the operating component.

TABLE A2.6-I.- OXYGEN AND HYDROGEN REPRESSURIZATION AND FLOW.

Quantity (percent)	Oxygen		Hydrogen	
	Repressurization time, minutes (865 to 935 psia)	Flow at 865 psia	Repressurization time, minutes (225 to 260 psia)	Flow at 225 psia
100	4.0	3.56	20.0	0.38
95	4.3	3.97	21.0	0.42
90	4.6	4.55	22.0	0.46
85	5.0	5.27	23.0	0.49
80	5.4	6.02	24.5	0.52
75	5.7	7.01	26.5	0.65
70	6.5	7.94	28.5	0.76
65	7.4	9.01	31.0	0.80
60	8.7	10.80	33.5	0.87
55	9.6	12.54	36.0	0.93
50	10.8	14.19	39.0	0.97
45	11.5	15.69	41.0	0.98
40	12.4	17.01	41.0	0.97
35	12.6	17.56	41.0	0.94
30	13.0	17.56	40.5	0.91
25	13.1	16.55	40.5	0.83
20	13.2	15.48	42.0	0.71
15	14.5	12.28	47.0	0.54
10	17.8	8.76	58.0	0.37
7.5	21.4	7.09	71.0	0.23
5	24.0	5.37	Continuous	0.16

To avoid excessive temperatures, which could be realized during continuous heater and fan operation at extremely low quantity levels, a thermal sensitive interlock device is in series with each heater element. The device automatically opens the heater circuits when internal tank shell temperatures reach +90° F., and closes the circuits at +70° F. Assuming normal consumption, oxygen temperature will be approximately -157° F., at mission termination, while hydrogen temperature will be approximately -385° F.

The manual mode of operation bypasses the pressure switches, and supplies power directly to the heaters and/or fans through the individual control switches. It can be used in case of automatic control failure, heater failure, or fan failure.

Tank pressures and quantities are monitored on meters located on MDC-2. The caution and warning system (CRYO PRESS) will alarm when oxygen pressure in either tank exceeds 950 psia or falls below 800 psia. The hydrogen system alarms above 270 psia and below 220 psia. Since a common lamp is provided, reference must be made to the individual pressure and quantity meters (MDC-2) to determine the malfunctioning tank. Tank pressures, quantities, and reactant temperatures of each tank are telemetered to MSFN.

Oxygen relief valves vent at a pressure between 983 and 1010 psig and reseal at 965 psig minimum. Hydrogen relief valves vent at a pressure between 273 and 285 psig, and reseal at 268 psig minimum. Full flow venting occurs approximately 2 pounds above relief valve opening pressure.

All the reactant tanks have vac-ion pumps to maintain the integrity of the vacuum between the inner and outer shell, thus maintaining heat leak at or below the design level. SM main dc bus A distributes power to the H₂ tank 1 pump and bus B to the H₂ tank 2 pump. Fuses provide power source protection. These fuses are removed during prelaunch to disable the circuit for flight. Circuit breakers, O₂ VAC ION PUMPS - MNA - MNB (RHEB-229), provide power source protection for the CM main buses, which distribute power to the O₂ vac-ion pumps. The circuit breakers allow use of the O₂ vac-ion pump circuits throughout flight, and provide a means of disabling circuit if necessary. The O₂ circuit breakers are opened on the launch pad, and closed at 90 percent tank quantity.

The most likely period of overpressurization in the cryogenic system will occur during operation in the minimum dq/dm region. The possibility of overpressurization is predicted on the assumption of a vacuum breakdown, resulting in an increase in heat leak. Also, under certain conditions, that is, extremely low power levels and/or a depressurized cabin,

demand may be lower than the minimum dq/dm flow necessary. Any of the preceding conditions would result in an increase of pressure within a tank.

In the case of hydrogen tank overpressurization, prior to reaching relief valve cracking pressure, tank pressure can be decreased by performing an unscheduled fuel cell hydrogen purge. A second method for relieving overpressure is to increase electrical loads, thus increasing fuel cell demand. However, in using this method, consideration must be given to the fact that there will be an increase in oxygen consumption, which may not be desirable.

Several procedures can be used to correct an overpressure condition in the oxygen system. One is to perform an unscheduled fuel cell purge. A second is to increase oxygen flow into the command module by opening the ECS DIRECT O_2 valve. The third is to increase electrical loads, which may not be desirable because this method will also increase hydrogen consumption.

A requirement for an overpressure correction in both reactant systems simultaneously is remote, since both reactant systems do not reach the minimum dq/dm region in parallel.

During all missions, to retain a single tank return capability, there is a requirement to maintain a balance between the two tanks in each of the reactant systems. When a 2- to 4-percent difference is indicated on the oxygen quantity meters (MDC-2), the O_2 HEATERS switch (MDC-2) of the lesser tank is positioned to OFF until tank quantities equalize. A 3-percent difference in the hydrogen quantity meters (MDC-2) will require positioning the H_2 HEATERS switch (MDC-2) of the lesser tank to OFF until tank quantities equalize. This procedure retains the automatic operation of the repressurization circuits, and provides for operation of the fan motors during repressurization to retain an accurate quantity readout in all tanks. The necessity for balancing should be determined shortly after a repressurization cycle, since quantity readouts will be most accurate at this time.

Batteries.- Five silver oxide-zinc storage batteries are incorporated in the EPS. These batteries are located in the CM lower equipment bay.

Three rechargeable entry and postlanding batteries (A, B, and C) power the CM systems after CSM separation and during postlanding. Prior to CSM separation, the batteries provide a secondary source of power while the fuel cells are the primary source. The entry batteries are used for the following purposes:

- a. Provide CM power after CSM separation
- b. Supplement fuel cell power during peak load periods (Delta V maneuvers)
- c. Provide power during emergency operations (failure of two fuel cells)
- d. Provide power for EPS control circuitry (relays, indicators, etc.)
- e. Provide sequencer logic power
- f. Provide power for recovery aids during postlanding
- g. Batteries A, B, or C can power pyro circuits by selection.

Each entry and postlanding battery is mounted in a vented plastic case and consists of 20 silver oxide-zinc cells connected in series. The cells are individually encased in plastic containers which contain relief valves that open at 35 ± 5 psig, venting during an overpressure into the battery case. The three cases can be vented overboard through a common manifold, the BATTERY VENT valve (RHEB-252), and the ECS waste water dump line.

Since the BATTERY VENT is closed prior to lift-off, the interior of the battery cases is at a pressure of one atmosphere. The pressure is relieved after earth orbit insertion and completion of cabin purge by positioning the control to VENT for 5 seconds. After completion the control is closed, and pressure as read out on position 4A of the System Test Meter (LEB-101) should remain at zero unless there is battery outgassing. Outgassing can be caused by an internal battery failure, an abnormal high-rate discharge, or by overcharging. If a pressure increase is noted on the system test meter, the BATTERY VENT is positioned to VENT for 5 seconds, and reclosed. Normal battery charging procedures require a check of the battery manifold after completion of each recharge.

Since the battery vent line is connected to the waste water dump line, it provides a means of monitoring waste water dump line plugging, which would be indicated by a pressure rise in the battery manifold line when the BATTERY VENT control is positioned to VENT.

Each battery is rated at 40-ampere hours (AH) minimum and will deliver this at a current output of 35 amps for 30 minutes and a subsequent output of 2 amps for the remainder of the rating.

At Apollo mission loads, each battery is capable of providing 45 AH and will provide this amount after each complete recharge cycle. However, 40 AH is used in mission planning for inflight capability, and 45 AH for postlanding capability of a fully charged battery.

Open circuit voltage is 37.2 volts. Sustained battery loads are extremely light (2 to 3 watts); therefore, a battery bus voltage of approximately 34 V dc will be indicated on the spacecraft voltmeter, except when the main bus tie switches have been activated to tie the battery outputs to the main dc buses. Normally, only batteries A and B will be connected to the main dc buses. Battery C is isolated during prelaunch by opening the MAIN A-BAT C and MAIN B-BAT C circuit breakers (RHEB-275). Battery C will therefore provide a backup for main dc bus power in case of failure of battery A or B or during the time battery A or B is being recharged. The two-battery configuration provides more efficient use of fuel cell power during peak power loads and decreases overall battery recharge time. The MAIN A- and MAIN B-BAT C circuit breakers are closed prior to CSM separation or as required during recharge of battery A or B.

Battery C, through circuit breakers BAT C to BAT BUS A and BAT C to BAT BUS B (RHEB-250), provides backup power to the respective battery bus in the event of failure of entry battery A or B. These circuit breakers are normally open until a failure of battery A or B occurs. This circuit can also be used to recharge battery A or B in the event of a failure in the normal charging circuit.

The two pyrotechnic batteries supply power to initiate ordnance devices in the SC. The pyrotechnic batteries are isolated from the rest of the EPS to prevent the high-power surges in the pyrotechnic system from affecting the EPS, and to insure source power when required. These batteries are not to be recharged in flight. Entry and postlanding battery A, B, or C can be used as a redundant source of power for initiating pyro circuits in the respective A or B pyro system, if either pyro battery fails. This can be performed by proper manipulation of the circuit breakers on RHEB-250. Caution must be exercised to isolate the failed pyro battery by opening the PYRO A (B) SEQ A (B) circuit breaker, prior to closing the yellow colored BAT BUS A (B) to PYRO BUS TIE circuit breaker.

Performance characteristics of each SC battery are as follows:

Battery	Rated capacity per battery	Open circuit voltage (max.)	Nominal voltage	Minimum voltage	Ambient battery temperature
Entry and Postlanding, A, B, and C (3)	40 amp-hrs (25 ampere rate)	37.8 V dc max. (37.2 V dc in flight)	29 V dc (35 amps load)	27 V dc (35 amps load)	50° to 110° F
Pyro A and B (2)	0.75 amp-hrs (75 amps for 36 seconds)	37.8 V dc max. (37.2 V dc in flight)	23 V dc (75 amps load)	20 V dc (75 amps load) (32 V dc open circuit)	60° to 110° F

NOTE: Pyro battery load voltage is not measurable in the SC due to the extremely short time they power pyro loads.

Fuel cell power plants. - Each of the three Bacon-type fuel cell power plants is individually coupled to a heat rejection (radiator) system, the hydrogen and oxygen cryogenic storage systems, a water storage system, and a power distribution system. A typical power plant schematic is shown in figure A2.6-5.

The power plants generate dc power on demand through an exothermic chemical reaction. The by-product water is fed to a potable water storage tank in the CM where it is used for astronaut consumption and for cooling purposes in the ECS. The amount of water produced is equivalent to the power produced which is relative to the reactant consumed. (See table A2.6-II.)

TABLE A2.6-II.- REACTANT CONSUMPTION AND WATER PRODUCTION

Load (amps)	O ₂ lb/hr	H ₂ lb/hr	H ₂ O lb/hr	cc/hr
0.5	0.0102	0.001285	0.01149	5.21
1	0.0204	0.002570	0.02297	10.42
2	0.0408	0.005140	0.04594	20.84
3	0.0612	0.007710	0.06891	31.26
4	0.0816	0.010280	0.09188	41.68
5	0.1020	0.012850	0.11485	52.10
6	0.1224	0.015420	0.13782	62.52
7	0.1428	0.017990	0.16079	72.94
8	0.1632	0.020560	0.18376	83.36
9	0.1836	0.023130	0.20673	93.78
10	0.2040	0.025700	0.2297	104.20
15	0.3060	0.038550	0.34455	156.30
20	0.4080	0.051400	0.45940	208.40
25	0.5100	0.064250	0.57425	260.50
30	0.6120	0.077100	0.68910	312.60
35	0.7140	0.089950	0.80395	364.70
40	0.8160	0.10280	0.91880	416.80
45	0.9180	0.11565	1.03365	468.90
50	1.0200	0.12850	1.1485	521.00
55	1.1220	0.14135	1.26335	573.10
60	1.2240	0.15420	1.3782	625.20
65	1.3260	0.16705	1.49305	677.30
70	1.4280	0.17990	1.6079	729.40
75	1.5300	0.19275	1.72275	781.50
80	1.6320	0.20560	1.83760	833.60
85	1.7340	0.21845	1.95245	885.70
90	1.8360	0.23130	2.06730	937.90
95	1.9380	0.24415	2.18215	989.00
100	2.0400	0.25700	2.2970	1042.00

FORMULAS:

$$O_2 = 2.04 \times 10^{-2} I$$

$$H_2 = 2.57 \times 10^{-3} I$$

$$H_2O = 10.42 \text{ cc/amp/hr}$$

$$H_2O = 2.297 \times 10^{-2} \text{ lb/amp/hr}$$

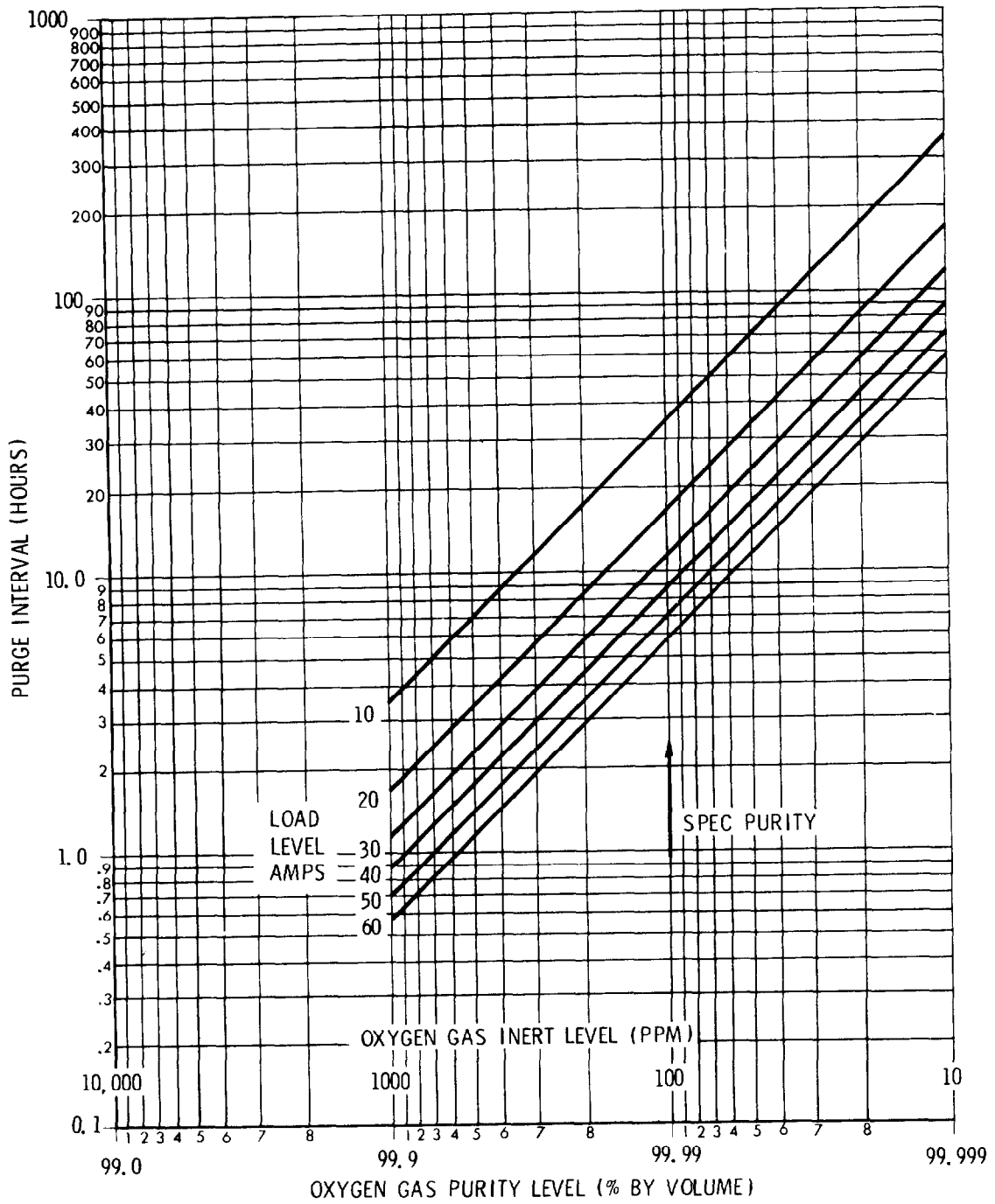

Figure A2.6-7.- O₂ gas purity effect on purge interval.

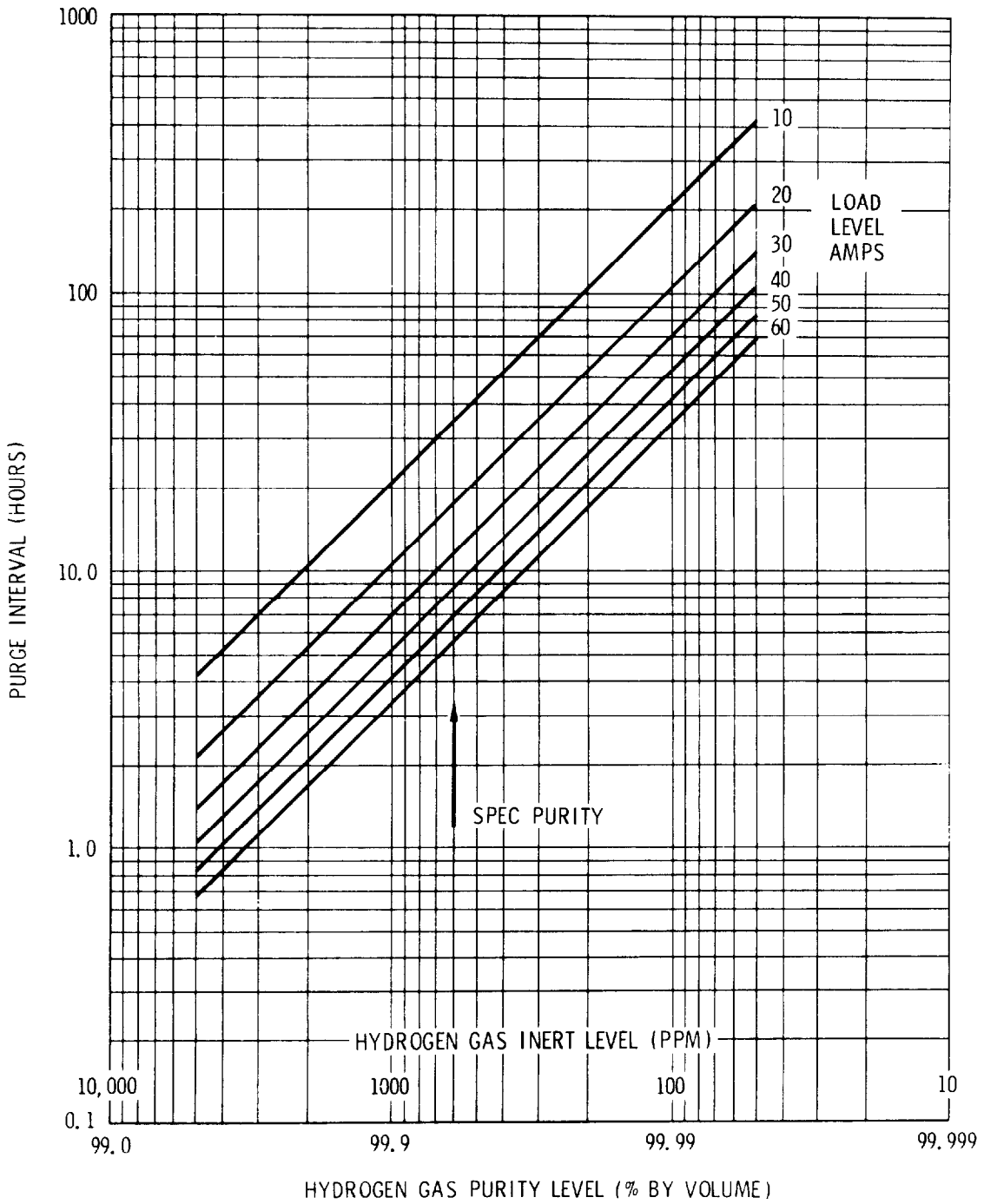

Figure A2.6-8.- H₂ gas purity effect on purge interval.

voltage, resulting from a decreased load, is followed by a gradual decrease in fuel cell skin temperature which causes a decrease in terminal voltage.

The range in which the terminal voltage is permitted to vary is determined by the high and low voltage input design limits of the components being powered. For most components the limits are 30 volts dc and 25 volts dc. To remain within these design limits, the dc bus voltage must be maintained between 31.0 and 26.2 volts dc. To compensate for cyclic loads, it is recommended sustained bus voltage be maintained between 26.5 and 30.0 V dc. Bus voltage is maintained within prescribed limits by the application of entry and postlanding batteries during load increases (power up). Load increase or decrease falls well within the limits of power supply capability and, under normal conditions, should not require other than normal checklist procedures.

Power up.- Powering up spacecraft systems is performed in one continuous sequence providing the main bus voltage does not decrease below 26.5 volts. If bus voltage decreases to this level, the power up sequence can be interrupted for the time required for fuel cell temperatures to increase with the resultant voltage increase or the batteries can be connected to the main buses thus reducing the fuel cell load. In most cases, powering up can be performed in one continuous sequence; however, when starting from an extremely low spacecraft load, it is probable that a power up interruption or earlier battery coupling may be required. The greatest load increase occurs while powering up for a delta V maneuver.

Power down.- Powering down spacecraft systems is performed in one continuous sequence providing the main bus voltage does not increase above 31.0 volts. Powering down from relatively high spacecraft load levels, that is, following a delta V, the sequence may have to be interrupted for the time required for fuel cell temperature, and as a result, bus voltage to decrease. To expedite power down, one fuel cell can be disconnected from the buses increasing the loads on the remaining fuel cells and decreasing bus voltage, thus allowing continuation of the power down sequence.

Fuel cell disconnect.- If the requirement arises to maintain a power plant on open circuit, temperature decay would occur at an average rate of approximately 6 deg/hr, with the automatic in-line heater circuit activating at a skin temperature of 385° F and maintaining power plant temperature at 385° F. In-line heater activation can be confirmed by a 4.5- to 6-amp indication as observed on the dc amps meter (MDC-3) with the dc indicator switch positioned to the open circuited fuel cell position. Reactant valves remain open. Fuel cell pumps can be turned off until the in-line heater circuit activates, at which time they must be on.

Closing of reactant valves during a power plant disconnect is dependent on the failure experienced. If power plant failure is such as to allow future use, that is, shutdown due to partially degraded output, it is recommended the reactant valves remain open to provide a positive reactant pressure. The valves should be closed after power-plant skin temperature decays below 300° F. The reactant valves are closed during initial shutdown, if the failure is a reactant leak, an abnormally high regulator output pressure, or complete power-plant failure.

Prior to disconnecting a fuel cell, if a single inverter is being used, each of the remaining power plants is connected to both main dc buses to enhance load sharing since bus loads are unbalanced. If two inverters are being used, main dc bus loads are relatively equal; therefore, each of the remaining power plants is connected to a separate main dc bus for bus isolation. If one power plant had been placed on open circuit for an extended period of time, prior to powering up to a configuration requiring three power plants, reconnecting is accomplished prior to the time of heavy load demands. This permits proper conditioning of the power plant which has been on open circuit. The time required for proper conditioning is a function of skin temperature increase and the load applied to the power plant.

Inverters.- Each inverter (fig. A2.6-9) is composed of an oscillator, an eight-stage digital countdown section, a dc line filter, two silicon controlled rectifiers, a magnetic amplifier, a buck-boost amplifier, a demodulator, two dc filters, an eight-stage power inversion section, a harmonic neutralization transformer, an ac output filter, current sensing transformers, a Zener diode reference bridge, a low-voltage control, and an overcurrent trip circuit. The inverter normally uses a 6.4-kHz square wave synchronizing signal from the central timing equipment (CTE) which maintains inverter output at 400 Hz. If this external signal is completely lost, the free running oscillator within the inverter will provide pulses that will maintain inverter output within ± 7 Hz. The internal oscillator is normally synchronized by the external pulse. The subsequent paragraphs describe the function of the various stages of the inverter.

The 6.4-kHz square wave provided by the CTE is applied through the internal oscillator to the eight-stage digital countdown section. The oscillator has two divider circuits which provide a 1600-Hz signal to the magnetic amplifier.

The eight-stage digital countdown section, triggered by the 6.4-kHz signal, produces eight 400-Hz square waves, each mutually displaced one pulse-time from the preceding and following wave. One pulse-time is 156 microseconds and represents 22.5 electrical degrees. The eight square waves are applied to the eight-stage power inversion section.

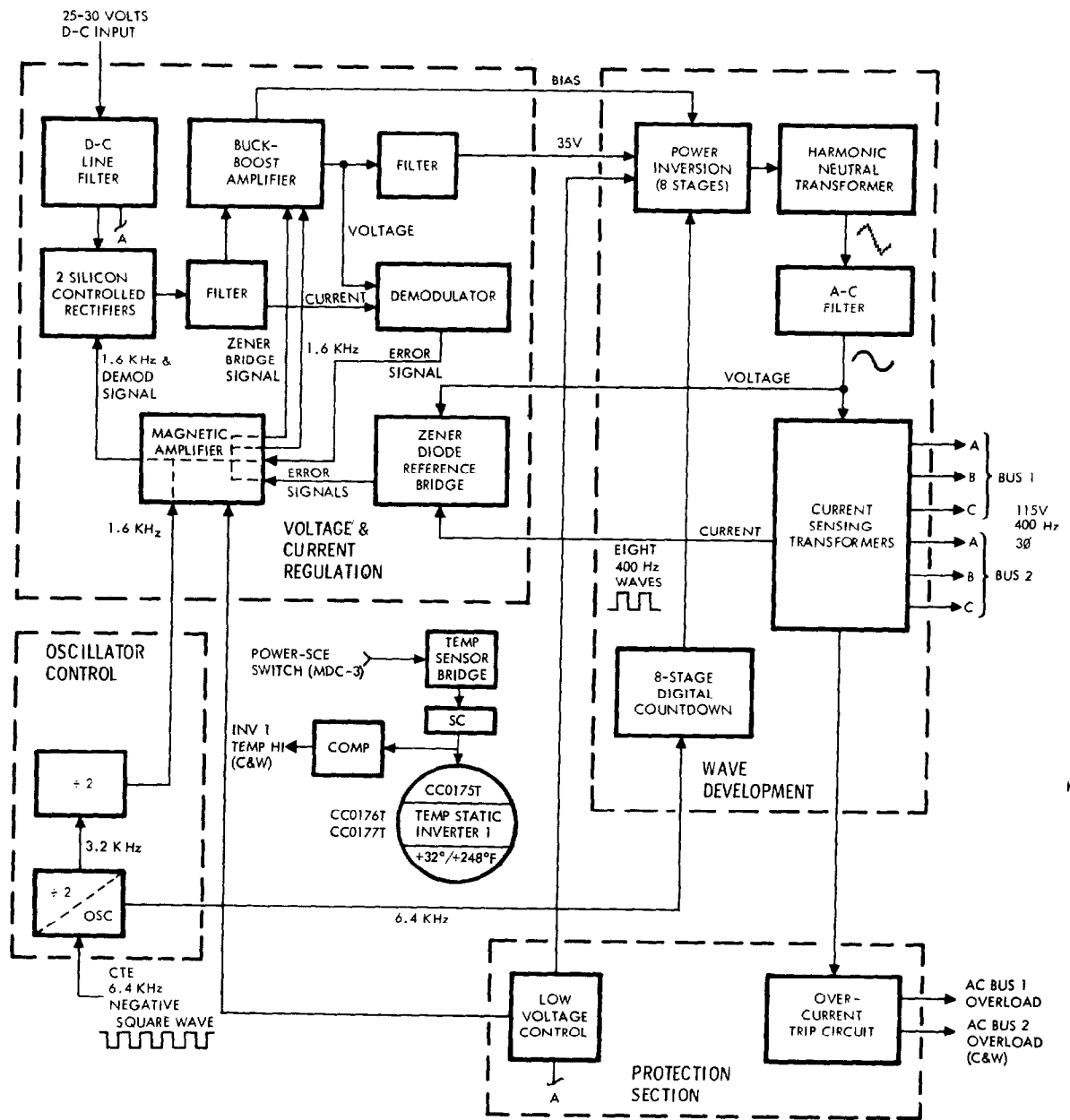

NOTE: Unless otherwise specified:
 1. Inverter 1 is shown.
 2. A denotes input voltage.

Figure A2.6-9.- Inverter block diagram.

The eight-stage power inversion section, fed a controlled voltage from the buck-boost amplifier, amplifies the eight 400-Hz square waves produced by the eight-stage digital countdown section. The amplified square waves, still mutually displaced 22.5 electrical degrees, are next applied to the harmonic neutralization transformer.

The harmonic neutralization section consists of 31 transformer windings on one core. This section accepts the 400-Hz square-wave output of the eight-stage power inversion section and transforms it into a 3-phase 400-Hz 115-volt signal. The manner in which these transformers are wound on a single core produces flux cancellation which eliminates all harmonics up to and including the fifteenth of the fundamental frequency. The 22.5° displacement of the square waves provides a means of electrically rotating the square wave excited primary windings around the 3-phase, wye-connected secondary windings, thus producing the 3-phase 400-Hz sine wave output. This 115-volt signal is then applied to the ac output filter.

The ac output filter eliminates the remaining higher harmonics. Since the lower harmonics were eliminated by the harmonic neutral transformer, the size and weight of this output filter was reduced. Circuitry in this filter also produces a rectified signal which is applied to the Zener diode reference bridge for voltage regulation. The amplitude of this signal is a function of the amplitude of ac output voltage. After filtering, the 3-phase 115-volt ac 400-Hz sine wave is applied to the ac buses through individual phase current-sensing transformers.

The current-sensing transformers produce a rectified signal, the amplitude of which is a direct function of inverter output current magnitude. This dc signal is applied to the Zener diode reference bridge to regulate inverter current output: it is also paralleled to an overcurrent sensing circuit.

The Zener diode reference bridge receives a rectified dc signal, representing voltage output, from the circuitry in the ac output filter. A variance in voltage output unbalances the bridge, providing an error signal of proper polarity and magnitude to the buck-boost amplifier via the magnetic amplifier. The buck-boost amplifier, through its bias voltage output, compensates for voltage variations. When inverter current output reaches 200 to 250 percent of rated current, the rectified signal applied to the bridge from the current sensing transformers is of sufficient magnitude to provide an error signal, causing the buck-boost amplifier to operate in the same manner as during an overvoltage condition. The bias output of the buck-boost amplifier, controlled by the error signal, will be varied to correct for any variation in inverter voltage or a beyond-tolerance increase in current output. When inverter current output exceeds 250 percent of rated current, the overcurrent sensing circuit is activated.

The overcurrent sensing circuit monitors a rectified dc signal representing current output. When total inverter current output exceeds 250 percent of rated current, this circuit will illuminate an overload lamp in 15 ± 5 seconds. If current output of any single phase exceeds 300 percent of rated current, this circuit will illuminate the overload lamp in 5 ± 1 seconds. The AC BUS 1 OVERLOAD and AC BUS 2 OVERLOAD lamps are in the caution/warning matrix on MDC-2.

The dc power to the inverter is supplied from the main dc buses through the dc line filter. The filter reduces the high-frequency ripple in the input, and the 25 to 30 volts dc is applied to two silicon-controlled rectifiers.

The silicon-controlled rectifiers are alternately set by the 1600-Hz signal from the magnetic amplifier to produce a dc square wave with an on-time of greater than 90° from each rectifier. This is filtered and supplied to the buck-boost amplifier where it is transformer-coupled with the amplified 1600-Hz output of the magnetic amplifier, to develop a filtered 35 volts dc which is used for amplification in the power inversion stages.

The buck-boost amplifier also provides a variable bias voltage to the eight-stage power inversion section. The amplitude of this bias voltage is controlled by the amplitude and polarity of the feedback signal from the Zener diode reference bridge which is referenced to output voltage and current. This bias signal is varied by the error signal to regulate inverter voltage and maintain current output within tolerance.

The demodulator circuit compensates for any low-frequency ripple (10 to 1000 Hz) in the dc input to the inverter. The high-frequency ripple is attenuated by the input filters. The demodulator senses the 35-volt dc output of the buck-boost amplifier and the current input to the buck-boost amplifier. An input dc voltage drop or increase will be reflected in a drop or increase in the 35-volt dc output of the buck-boost amplifier, as well as a drop or increase in current input to the buck-boost amplifier. A sensed decrease in the buck-boost amplifier voltage output is compensated for by a demodulator output, coupled through the magnetic amplifier to the silicon-controlled rectifiers. The demodulator output causes the SCR's to conduct for a longer time, thus increasing their filtered dc output. A sensed increase in buck-boost amplifier voltage output, caused by an increase in dc input to the inverter, is compensated for by a demodulator output coupled through the magnetic amplifier to the silicon-controlled rectifiers, causing them to conduct for shorter periods, thus producing a lower filtered dc output to the buck-boost amplifier. In this manner, the 35-volt dc input to the power inversion section is maintained at a relatively constant level irrespective of the fluctuations in dc input voltage to the inverter.

The low-voltage control circuit samples the input voltage to the inverter and can terminate inverter operation. Since the buck-boost amplifier provides a boost action during a decrease in input voltage to the inverter, in an attempt to maintain a constant 35 volts dc to the power inversion section and a regulated 115-volt inverter output, the high boost required during a low-voltage input would tend to overheat the solid state buck-boost amplifier. As a precautionary measure, the low-voltage control will terminate inverter operation by disconnecting operating voltage to the magnetic amplifier and the first power inversion stage when input voltage decreases to between 16 and 19 volts dc.

A temperature sensor with a range of +32° to +248° F is installed in each inverter and provides an input to the C&WS which will illuminate a light at an inverter overtemperature of 190° F. Inverter temperature is telemetered to MSFN.

Battery charger.- A constant voltage, solid-state battery charger (fig. A2.6-10), located in the CM lower equipment bay, is incorporated into the EPS. The BATTERY CHARGER selector switch (MDC-3) controls power input to the charger, as well as connecting the charger output to the selected battery (fig. A2.6-14). When the BATTERY CHARGER selector switch is positioned to entry battery A, B, or C, a relay (K1) is activated completing circuits from ac and dc power sources to the battery charger. Battery charger output is also connected to the selected battery to be charged through contacts of the MAIN BUS TIE motor switch. Positioning the MAIN BUS TIE switch (A/C or B/C) to OFF for battery A or B, and both switches to OFF for battery C will disconnect main bus loads from the respective batteries and also complete the circuit from the charger to the battery.

The battery charger is provided 25 to 30 volts from both main dc buses and 115 volts 400-Hz 3-phase from either of the ac buses. All three phases of ac are used to boost the 25- to 30-volt dc input and produce 40 volts dc for charging. In addition, phase A of the ac is used to supply power for the charger circuitry. The logic network in the charger, which consists of a two-stage differential amplifier (comparator), Schmitt trigger, current sensing resistor, and a voltage amplifier, sets up the initial condition for operation. The first stage of the comparator is in the on mode, with the second stage off, thus setting the Schmitt trigger first stage to on with the second stage off. Maximum base drive is provided to the current amplifier which turns the switching transistor to the on mode. With the switching transistor on, current flows from the transformer rectifier through the switching transistor, current sensing resistor, and switch choke to the battery being charged. Current lags voltage due to switching choke action. As current flow increases, the voltage drop across the sensing resistor increases, and at a specific level sets the first stage of the comparator to off and the second stage

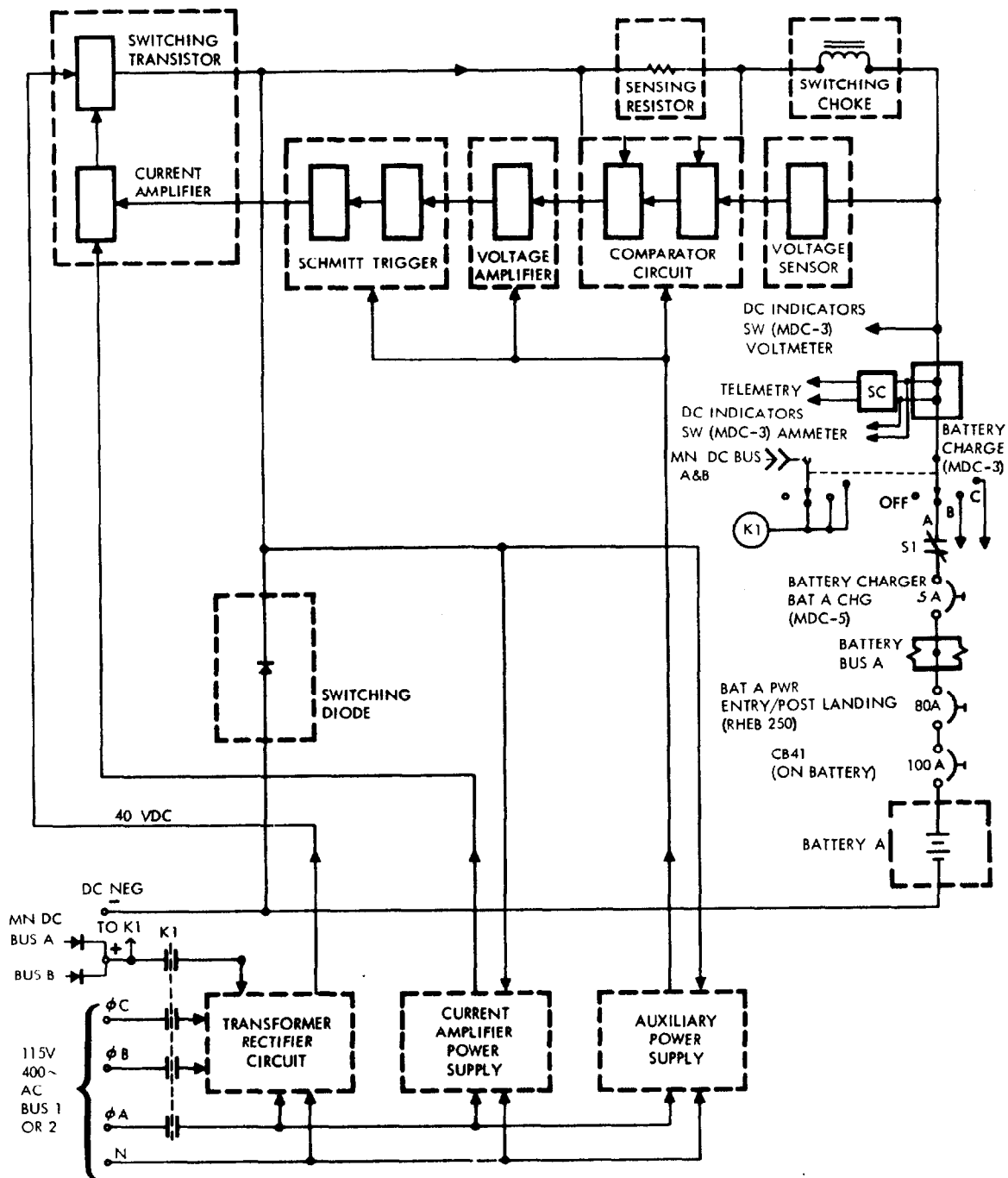

Figure A2.6-10.- Battery charger block diagram.

to on. The voltage amplifier is set off to reverse the Schmitt trigger to first stage off and second stage on. This sets the current amplifier off, which in turn sets the switching transistor off. The switching transistor in the off mode terminates power from the source, causing the field in the choke to continue collapsing, discharging into the battery, then through the switching diode and the current sensing resistor to the opposite side of the choke. As the EMF in the choke decreases, current through the sensing resistor decreases, reducing the voltage drop across the resistor. At some point, the decrease in voltage drop across the sensing resistor reverses the comparator circuit, setting up the initial condition and completing one cycle of operation. The output load current, due to the choke action, remains relatively constant except for the small variation through the sensing resistor. This variation is required to set and reset the switching transistor and Schmitt trigger through the action of the comparator.

Battery charger output is regulated by the sensing resistor until battery voltage reaches approximately 37 volts. At this point, the biased voltage sensor circuit is unbiased, and in conjunction with the sensing resistor, provides a signal for cycling the battery charger. As battery voltage increases, the internal impedance of the battery increases, decreasing current flow from the charger. At 39.8 volts, the battery is fully charged and current flow becomes negligible. Recharging the batteries until battery amp hour input equates amp hours previously discharged from the battery assures sufficient battery capacity for mission completion. The MSFN will monitor this function. If there is no contact with the MSFN, battery charging is terminated when the voltmeter indicates 39.5 V dc with the DC INDICATORS switch set to the BAT CHARGER position.

Charger voltage is monitored on the DC VOLTS METER (MDC-3). Current output is monitored on the inner scale of the DC AMPS meter (MDC-3) by placing the DC INDICATORS switch (MDC-3) to the BAT CHARGER position. Battery charger current output is telemetered to the MSFN.

When charging battery A or B, the respective BAT RLY BUS-BAT A or B circuit breaker (MDC-5) is opened to expedite recharge. During this period, only one battery will be powering the battery relay bus. Relay bus voltage can be monitored by selecting positions 4 and B on the Systems Test Meter (LEB-101) and from the couches by the Fuel Cell-Main Bus B-1 and Fuel Cell - Main Bus A-3 talk-back indicators (MDC-3) which will be barber-poled. If power is lost to the relay bus, these indicators will revert to the gray condition, indicating loss of power to the relay bus and requiring remedial action.

Recharge of a battery immediately after it is exposed to any appreciable loads requires less time than recharge of a battery commencing 30 minutes or more after it is disconnected from these loads. Therefore, it is advantageous to connect batteries to the charger as soon as possible

after they are disconnected from the main buses since this decreases overall recharge time.

Power distribution.- The dc and ac power distribution to components of the EPS is provided by two redundant buses in each system. A single-point ground on the spacecraft structure is used to eliminate ground loop effects. Sensing and control circuits are provided for monitoring and protection of each system.

Distribution of dc power (fig. A2.6-11) is accomplished with a two-wire system and a series of interconnected buses, switches, circuit breakers, and isolation diodes. The dc negative buses are connected to the vehicle ground point (VGP). The buses consist of the following:

- a. Two main dc buses (A and B), powered by the three fuel cells and/or entry and postlanding batteries A, B, and C.
- b. Two battery buses (A and B), each powered by its respective entry and postlanding battery A and B. Battery C can power either or both buses if batteries A and/or B fail.
- c. Flight and postlanding bus, powered through both main dc buses and diodes, or directly by the three entry and postlanding batteries A, B, and C, through dual diodes.
- d. Flight bus, powered through both main dc buses and isolation diodes.
- e. Nonessential bus, powered through either dc main bus A or B.
- f. Battery relay bus, powered by entry and postlanding batteries through the individual battery buses and isolation diodes.
- g. Pyro buses, isolated from the main electrical power system when powered by the pyro batteries. A capability is provided to connect either entry battery to the A or B pyro system in case of loss of a pyro battery.
- h. SM jettison controllers, completely isolated from the main electrical power system until activated during CSM separation, after which they are powered by the fuel cells.

Power from the fuel cell power plants can be connected to the main dc buses through six motor switches (part of overload/reverse current circuits in the SM) which are controlled by switches in the CM located on MDC-3. Fuel cell power can be selected to either or both of the main dc buses. Six talk-back indicators show gray when fuel cell output is connected and striped when disconnected. When an overload condition occurs, the overload-reverse current circuits in the SM automatically

disconnect the fuel cell power plants from the overloaded bus and provide visual displays (talk-back indicator and caution and warning lamp illumination)(FC BUS DISCONNECT) for isolation of the trouble. A reverse current condition will disconnect the malfunctioning power plant from the dc system. The dc undervoltage sensing circuits (fig. A2.6-12) are provided to indicate bus low-voltage conditions. If voltage drops below 26.25 volts dc, the applicable dc undervoltage light on the caution and warning panel (MDC-2) will illuminate. Since each bus is capable of handling all EPS loads, an undervoltage condition should not occur except in an isolated instance; if too many electrical units are placed on the bus simultaneously or if a malfunction exists in the EPS. A voltmeter (MDC-3) is provided to monitor voltage of each main dc bus, the battery charger, and each of the five batteries. An ammeter is provided (MDC-3) to monitor current output of fuel cells 1, 2, 3, batteries A, B, C, and the battery charger.

During high power demand or emergencies, supplemental power to the main dc buses can be supplied from batteries A and B via the battery buses and directly from battery C (fig. A2.6-13). During entry, spacecraft power is provided by the three entry and postlanding batteries which are connected to the main dc buses prior to CSM separation; placing the MAIN BUS TIE switches (MDC-5) to BAT A/C and BAT B/C provides this function after closing the MAIN A-BAT C and MAIN B-BAT C circuit breakers (RHEB-275). The switches are manually placed to OFF after completion of RCS purge and closing the FLIGHT AND POST LDG-BAT BUS A, BAT BUS B, and BAT C circuit breakers (RHEB-275) during main chute descent. The AUTO position provides an automatic connection of the entry batteries to the main dc buses at CSM separation. The auto function is used only on the launch pad after the spacecraft is configured for a LES pad abort.

A nonessential bus, as shown on fig. A2.6-11, permits isolating non-essential equipment during a shortage of power (two fuel cell power plants out). The flight bus distributes power to inflight telecommunications equipment. The flight and postlanding bus distributes power to some of the inflight telecommunications equipment, float bag No. 3 controls, the ECS postlanding vent and blower control, and postlanding communications and lighting equipment. In flight, the postlanding bus receives power from the fuel cells and/or entry and postlanding batteries through the main dc buses. After completion of RCS purge during main chute descent, the entry batteries supply power to the postlanding bus directly through individual circuit breakers. These circuit breakers (FLIGHT & POST LANDING-BAT BUS A, BAT BUS B, and BAT C - RHEB-275) are normally open in flight and closed during main chute descent just prior to positioning the MAIN BUS TIE switches to OFF.

Motor switch contacts which close when the MAIN BUS TIE switches are placed to ON, complete the circuit between the entry and postlanding batteries and the main dc buses, and open the connection from the battery

charger to the batteries. The battery relay bus provides dc power to the ac sensing units, the fuel cell and inverter control circuits, fuel cell reactant and radiator valves, and the fuel cell-main BUS A and B talk-back indicators on MDC-3. The pyrotechnic batteries supply power to ordnance devices for separation of the LES, S-IVB, forward heat shield, SM from CM, and for deployment and release of the drogue and main parachutes during a pad abort, high-altitude abort, or normal mission progression. The three fuel cell power plants supply power to the SM jettison controllers for the SM separation maneuver.

Distribution of ac power (fig. A2.6-14) is accomplished with a four-wire system via two redundant buses, ac bus 1 and ac bus 2. The ac neutral bus is connected to the vehicle ground point. The ac power is provided by one or two of the solid-state 115/200-volt 400-Hz 3-phase inverters. The dc power is routed to the inverters through the main dc buses. Inverter No. 1 is powered through dc main bus A, inverter No. 2 through dc main bus B, and inverter No. 3 through either dc main bus A or B by switch selection. Each of these circuits has a separate circuit breaker and a power control motor switch. Switches for applying power to the motor switches are located on MDC-3. All three inverters are identical and are provided with overtemperature circuitry. A light indicator, in the caution/warning group on MDC-2, illuminates at 190° to indicate an overtemperature situation. Inverter output is routed through a series of control motor switches to the ac buses. Six switches (MDC-3) control motor switches which operate contacts to connect or disconnect the inverters from the ac buses. Inverter priority is 1 over 2, 2 over 3, and 3 over 1 on any one ac bus. This indicates that inverter 2 cannot be connected to the bus until the inverter 1 switch is positioned to OFF. Also, when inverter 3 switch is positioned to ON, it will disconnect inverter 1 from the bus before the inverter 3 connection will be performed. The motor switch circuits are designed to prevent connecting two inverters to the same ac bus at the same time. The ac loads receive power from either ac bus through bus selector switches. In some instances, a single phase is used for operation of equipment and in others all three. Overvoltage and overload sensing circuits (fig. A2.6-12) are provided for each bus. An automatic inverter disconnect is effected during an overvoltage. The ac bus voltage fail and overload lights in the caution/warning group (MDC-2) provide a visual indication of voltage or overload malfunctions. Monitoring voltage of each phase on each bus is accomplished by selection with the AC INDICATORS switch (MDC-3). Readings are displayed on the AC VOLTS meter (MDC-3). Phase A voltage of each bus is telemetered to MSFN stations.

Several precautions should be taken during any inverter switching. The first precaution is to completely disconnect the inverter being taken out of the circuit whether due to inverter transfer or malfunction. The second precaution is to insure that no more than one switch on AC BUS 1 or AC BUS 2 (MDC-3) is in the up position at the same time. These

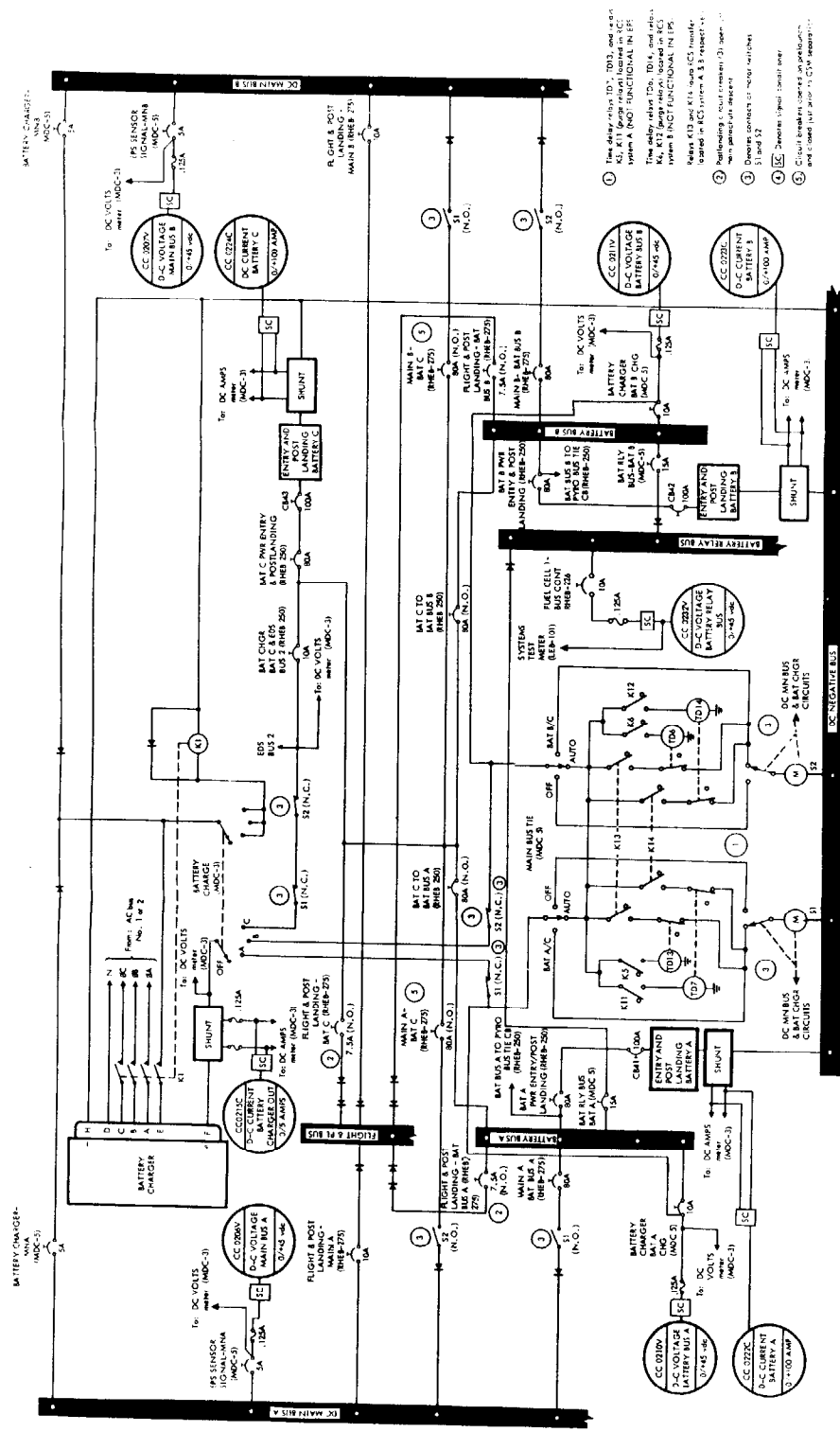

Figure A2.6-13. - Battery charger and DC bus control circuitry.

precautions are necessary to assure positive power transfer since power to any one inverter control motor switch is routed in series through the switch of another inverter. A third precaution must be exercised to preclude a motor switch lockout when dc power to inverter 3 is being transferred from dc main bus A to dc main bus B, or vice versa. The AC INVERTER 3 switch (MDC-3) should be held in the OFF position for 1 second when performing a power transfer operation from one main dc bus to the other.

Performance and Design Data

Alternating current and direct current data.- The ac and dc performance and design data for the EPS is as follows:

Alternating current

Phases	3
Displacement	$120 \pm 2^\circ$
Steady-state voltage	115.5 (+1, -1.5) V ac (average 3 phases)
Transient voltage	115 (+35, -65) V ac
Recovery	To 115 ± 10 V within 15 ms, steady state within 50 ms
Unbalance	2 V ac (worst phase from average)
Frequency limites	
Normal (synchronized to central timing equipment)	400 ± 3 Hz
Emergency (loss of central timing equipment)	400 ± 7 Hz
Wave characteristics (sine wave)	
Maximum distortion	5 percent
Highest harmonic	4 percent
Crest factor	1.414 ± 10 percent
Rating	1250 V ac

Direct current

Steady-state voltage limits	
Normal	29 ± 2.0 V dc
Minimum CM bus	26.2 V dc
Min Precautionary CM bus	26.5 V dc (allows for cyclic loads)
Maximum CM bus	31.0 V dc
Max Precautionary CM bus	30.0 V dc (allows for cyclic loads)
During postlanding and preflight checkout periods	27 to 30 V dc
Ripple voltage	1 V peak to peak

Operational Limitations and Restrictions

Fuel cell power plants.- Fuel cell power plants are designed to function under atmospheric and high-vacuum conditions. Each must be able to maintain itself at sustaining temperatures and minimum electrical loads at both environment extremes. To function properly, fuel cells must operate under the following limitations and restrictions:

External nonoperating temperature	-20° to +140° F.
Operating temperature inside SM	+30° to 145° F.
External nonoperating pressure	Atmospheric
Normal voltage	27 to 31 V dc
Minimum operating voltage at terminals	
Emergency operation	20.5 V dc at 2295 watts (gross power level)
Normal operation	27 V dc

Maximum operating voltage 31.5 V dc
at terminals

Fuel cell disconnect 75 amperes no trip, 112 amperes
overload disconnect after 25 to 300 seconds

Maximum reverse current 1 second minimum before disconnect

Minimum sustaining power/ 420 watts
fuel cell power plant
(with in-line heater OFF)

In-line heater power 160 watts
(sustain F/C skin temp (5 to 6 amps)
above 385° F min)

Maximum gross power 2295 watts at 20.5 V dc min.
under emergency
conditions

Nitrogen pressure 50.2 to 57.5 psia (53 psia, nominal)

Reactant pressure
Oxygen 58.4 to 68.45 psia (62.5 psia,
nominal)

Hydrogen 57.3 to 67.0 psia (61.5 psia,
nominal)

Reactant consumption/fuel
cell power plant

Hydrogen PPH = Amps x (2.57×10^{-3})
Oxygen PPH = Amps x (2.04×10^{-2})

Minimum skin temperature +385° F
for self-sustaining
operation

Minimum skin temperature +360° F
for recovery in flight

Maximum skin temperature +500° F

Approximate external -260° to +400° F
environment temperature
range outside SC (for
radiation)

Fuel cell power plant normal operating temperature range	+385° to +450° F
Condenser exhaust normal operating temperature	+150° to +175° F
Purging nominal frequency	Dependent on mission load profile and reactant purity after tank fill
O ₂ purge duration	2 minutes
H ₂ purge duration	80 seconds
Additional flow rate while purging	
Oxygen	Up to 0.6 lb/hr
Hydrogen	Up to 0.75 lb/hr (nominal 0.67 lb/hr)

Cryogenic storage subsystem.- The cryogenic storage subsystem must be able to meet the following requirements for proper operation of the fuel cell power plants and the ECS:

Minimum usable quantity	
Oxygen	320 lbs each tank (min)
Hydrogen	28 lbs each tank (min)
Temperature at time of fill	
Oxygen	-297° F. (approx.)
Hydrogen	-423° F. (approx.)
Operating pressure range	
Oxygen	
Normal	865 to 935 psia
Minimum	150 psia
Hydrogen	
Normal	225 to 260 psia
Minimum	100 psia
Temperature probe range	
Oxygen	-325° to +80° F
Hydrogen	-425° to -200° F
Maximum allowable difference in quantity balance between tanks	

Oxygen tanks No. 1 and 2 2 to 4 percent
2
Hydrogen tanks No. 1 3 percent
and 2

Pressure relief valve
operation

Crack pressure

Oxygen 983 psig min.

Hydrogen 273 psig min.

Reseat pressure

Oxygen 965 psig min.

Hydrogen 268 psig min.

Full flow, maximum
relief

Oxygen 1010 psig max.

Hydrogen 285 psig max.

Additional data. - Additional data about limitations and restrictions may be found in the CSM/LM Spacecraft Operational Data Book SNA-8-D-027, Vol I, (CSM SD68-447).

Systems Test Meter

The SYSTEMS TEST meter and the alphabetical and numerical switches, located on panel 101 in the CM LEB, provide a means of monitoring various measurements within the SC, and verifying certain parameters displayed only by event indicators. The following can be measured using the SYSTEMS TEST meter, the respective switch positions, and the range of each sensor. Normal operating parameters of measurable items are covered in the telemetry listing.

Conversion of the previously listed measurements to the SYSTEMS TEST meter indications are listed in Table A2.6-IV. The XPNDR measurements are direct readouts and do not require conversion.

TABLE A2.6-III.- SYSTEMS TEST DATA

Systems test indication (telemetry identity and code no.)	Switch positions		Sensor range
	Numerical select	Alphabetical select	
N ₂ pressure, psia F/C 1 SC 2060P F/C 2 SC 2061P F/C 3 SC 2062P	1 1 1	A B C	0 to 75 psia
O ₂ pressure, psia F/C 1 SC 2066P F/C 2 SC 2067P F/C 3 SC 2068P	1 2 2	D A B	0 to 75 psia
H ₂ pressure, psia F/C 1 SC 2069P F/C 2 SC 2070P F/C 3 SC 2071P	2 2 3	C D A	0 to 75 psia
EPS radiator outlet temperature F/C 1 SC 2087T F/C 2 SC 2088T F/C 3 SC 2089T	3 3 3	B C D	-50° to +300° F
Battery manifold pressure, psia	4	A	0 to 20 psia
Batt relay bus CCO232V	4	B	0 to +45 V dc
LM power	4	D	0 to +10 amps
SPS oxidizer line temperature SP 0049T	5	A	0 to +200° F
CM-RCS oxidizer valve temperature			-50° to +50° F
-P engine, sys A CR 2100T	6	B	
+Y engine, sys B CR 2116T	5	D	
-P engine, sys B CR 2110T	5	C	
CW engine, sys B CR 2119T	6	D	
CCW engine, sys A CR 2114T	6	A	
-Y engine, sys A CR 2103T	6	C	
Pwr output	XPNDR	A	≥1.0 V dc (nominal)
AGC signal	XPNDR	B	Test ≥1.0 V dc Operate 0.0 to 4.5 V dc
Phase lockup	XPNDR	C	Locked ≥4.0 V dc Unlocked <0.8 V dc

NOTE: Position 7 on the numerical selector switch is an off position.

Command Module Interior Lighting

The command module interior lighting system (fig. A2.6-15) furnishes illumination for activities in the couch, lower equipment bay and tunnel areas, and back-lighted panel lighting to read nomenclature, indicators, and switch positions. Tunnel lighting is provided on SC which will be concerned with LM activity.

Floodlighting for illumination of work areas is provided by use of fluorescent lamps. Integral panel and numerics lighting is provided by electroluminescent materials. Tunnel lights are incandescent. Pen flashlights are provided for illuminating work areas which cannot be illuminated by the normal spacecraft systems, such as under the couches.

Electroluminescence (EL) is the phenomena whereby light is emitted from a crystalline phosphor ($Z_N S$) placed as a thin layer between two closely spaced electrodes of an electrical capacitor. One of the electrodes is a transparent material. The light output varies with voltage and frequency and occurs as light pulses, which are in-phase with the input frequency. Advantageous characteristics of EL for spacecraft use are an "after-glow" of less than 1 second, low power consumption, and negligible heat dissipation.

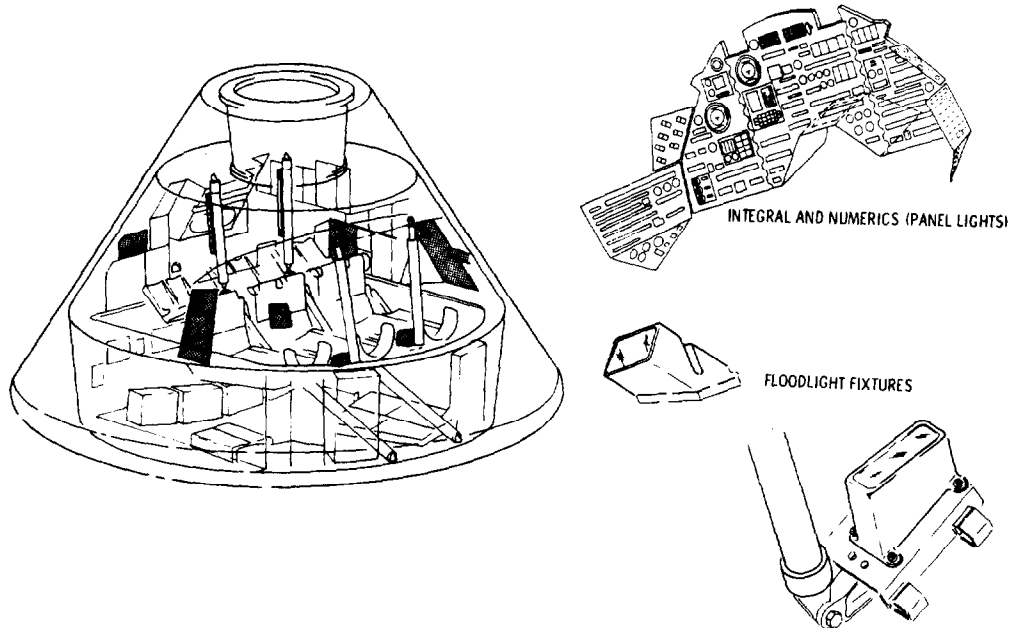

Figure A2.6-15.- CM interior lighting.

TABLE A2.6-IV.- SYSTEMS TEST METER INDICATIONS

Systems test meter display	N ₂ , O ₂ , H ₂ pressure (PSIA)	EPS radiator outlet temperature (° F.)	CM-RCS oxidizer valve temperature (° F.)	LM power (amps)	SPS temperature (° F.)	Battery manifold pressure (PSIA)	Battery relay bus (v dc)
0.0	0	-50					
0.2	3	-36	-50	0	0	0.00	0
0.4	6	-22	-46	0.4	8	0.80	1.8
0.6	9	-8	-42	0.8	16	1.60	3.6
0.8	12	+6	-38	1.2	24	2.40	5.4
1.0	15	+20	-34	1.6	32	3.20	7.2
1.2	18		-30	2.0	40	4.00	9.0
1.4	21	+34	-26	2.4	48		
1.6	24	+48	-22	2.8	56	4.80	10.8
1.8	27	+62	-18	3.2	64	5.60	12.6
2.0	30	+76	-14	3.6	72	6.40	14.4
2.2	33	+90	-10	4.0	80	7.20	16.2
2.4	36	+104	-6	4.4		8.00	18.0
2.6	39	+118	-4	4.8	88		
2.8	42	+132	0	5.2	96	8.80	19.8
3.0	45	+146	+4	5.6	104	9.60	21.6
3.2	48	+160	+10	6.0	112	10.40	23.4
3.4	51	+174	+14		120	11.20	25.2
3.6	54	+188	+18	6.4		12.00	27.0
3.8	57	+202	+22	6.8	128	12.80	
4.0	60	+216	+26	7.2	136	13.60	28.8
4.2	63	+230	+30	7.6	144	14.40	30.6
4.4	66	+244	+34	8.0	152	15.20	32.4
4.6	69	+258	+38	8.4	160	16.00	34.2
4.8	72	+272	+42	8.8			36.0
5.0	75	+286	+46	9.2	168	16.80	37.8
		+300	+50	9.6	176	17.60	39.6
				10.0	184	18.40	41.4
					192	19.20	43.2
					200	20.00	45.0

A-73

Floodlight system.- The interior floodlight system consists of six floodlight fixture assemblies and three control panels (fig. A2.6-16). Each fixture assembly contains two fluorescent lamps (one primary and one secondary) and converters. The lamps are powered by 28 V dc from main dc buses A and B (fig. A2.6-17). This assures a power source for lights in all areas in the event either bus fails. The converter in each floodlight fixture converts 28 V dc to a high-voltage pulsating dc for operation of the fluorescent lamps.

Floodlights are used to illuminate three specific areas: the left main display console, the right main display console, and the lower equipment bay. Switches on MDC-8 provide control of lighting of the left main display console area. Switches on MDC-5 provide control of lighting of the right main display console area. Switches for control of lighting of the lower equipment bay area are located on LEB-100. Protection for the floodlight circuits is provided by the LIGHTING - MN A and MN B circuit breakers on RHEB-226.

Each control panel has a dimming (DIM-1-2) toggle switch control, a rheostat (FLOOD-OFF-BRT) control, and an on/off (FIXED-OFF) toggle switch control. The DIM-1 position provides variable intensity control of the primary flood lamps through the FLOOD-OFF-BRT rheostat, and on-off control of the secondary lamps through the FIXED-OFF switch. The DIM-2 position provides variable intensity control of the secondary lamps through the FLOOD-OFF-BRT rheostat, and on-off control of the primary lamps through the FIXED-OFF switch. When operating the primary lamps under variable intensity control (DIM-1 position), turn on of the lamps is acquired after the FLOOD-OFF-BRT rheostat is moved past the midpoint. In transferring variable intensity control to the secondary lamps, the FLOOD-OFF-BRT rheostat should first be rotated to the OFF position before placing the DIM switch to the DIM-2 position. The rheostat is then moved to the full bright setting and should remain in this position unless dimming is desired. Dimming of the secondary flood lamps should not be used unless dimming control of the primary floodlights is not available. Dimming of the secondary lamps results in approximately a 90-percent reduction in lamp life. The range of intensity variation is greater for the primary than the secondary floodlights.

The commander's control panel (MDC-8) has a POST LANDING-OFF-FIXED switch which connects the flight and postlanding bus to his floodlights (fig. A2.6-17). The POST LANDING position provides single intensity lighting to the commander's primary or secondary lamps as selected by the DIM-1 or DIM-2 position, respectively. It is for use during the latter stages of descent after main dc bus power is disconnected, and during postlanding.

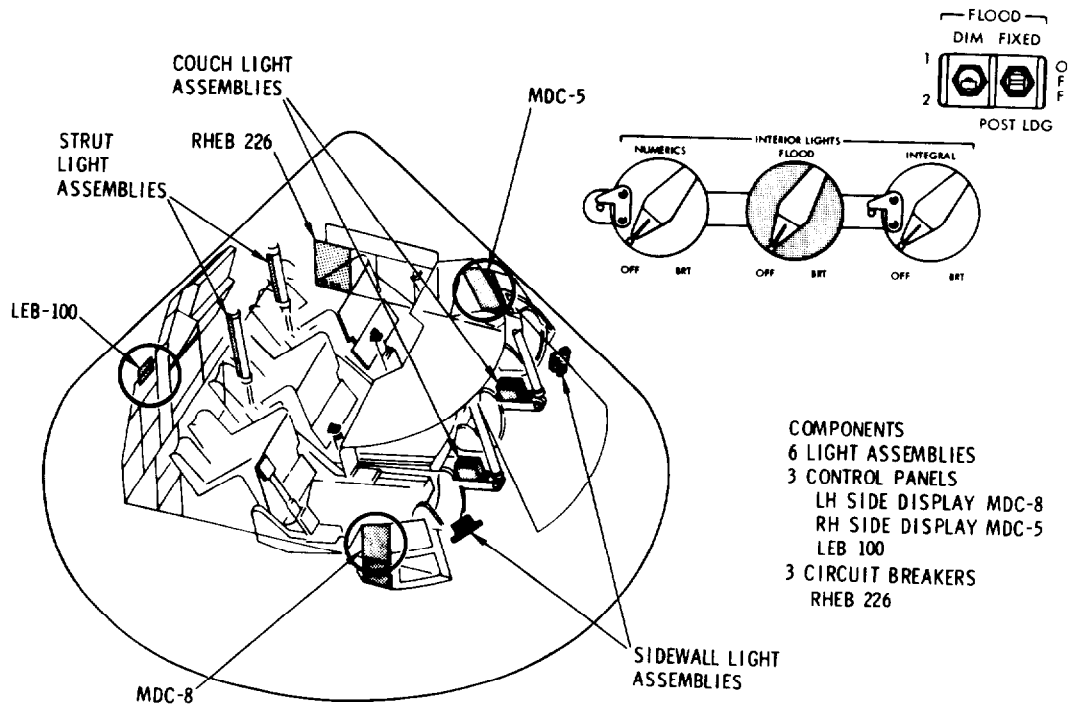

Figure A2.6-16.- CM floodlight configuration.

A-76

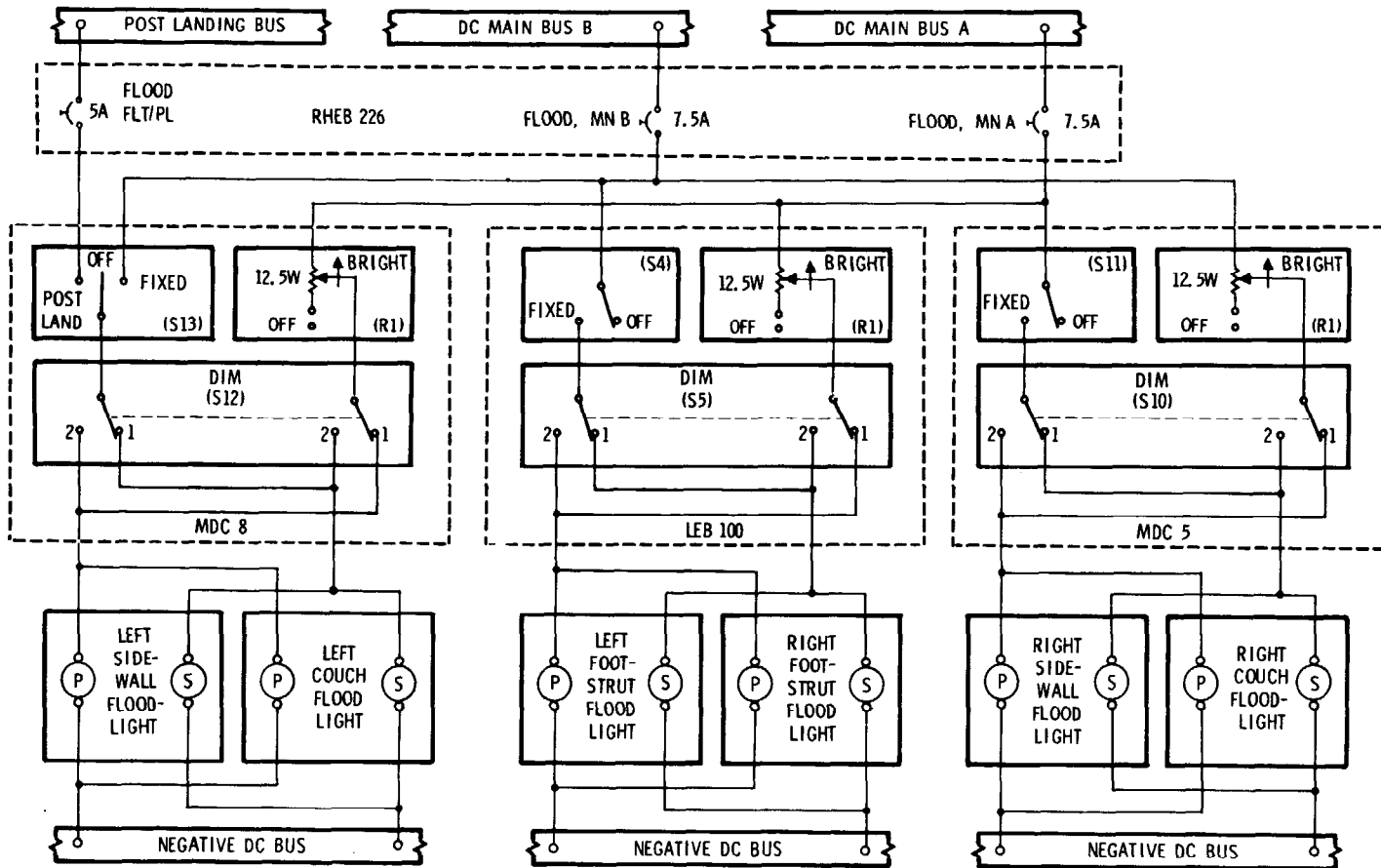

Figure A2.6-17.- CM floodlight system schematic.

Integral lighting system.- The integral lighting system controls the EL lamps behind the nomenclature and instrument dial faces on all MDC panels, and on specific panels in the lower equipment bay, left hand equipment bay, and right hand equipment bay (figs. A2.6-18 and A2.6-19). The controls (fig. A2.6-18) are rotary switches controlling variable transformers powered through the appropriate ac bus. Each rotary control switch has a mechanical stop which prevents the switch being positioned to OFF. Disabling of a circuit because of malfunctions is performed by opening the appropriate circuit breaker on RHEB-226. The INTEGRAL switch on MDC-8 controls the lighting of panels viewed by the commander, MDC-1, 7, 8, 9, 15, and the left half of 2. The INTEGRAL switch on MDC-5 controls the lighting of panels viewed by the LM pilot, MDC-3, 4, 5 and 6, 16, RHEB-229 and 275, and the right half of MDC-2. The INTEGRAL switch on LEB-100 controls the lighting of MDC-10, LEB-100, 101, 122 and the DSKY lights on 140, RHEB-225, 226 and LHEB 306. Intensity of the lighting can be individually controlled in each of the three areas.

Numerics lighting system.- Numerics lighting control is provided over all electroluminescent digital readouts. The NUMERICS rotary switch on MDC-8 controls the off/intensity of numerals on the DSKY and Mission Timer on MDC-2, and the range and delta V indicators of the Entry Monitor System of MDC-1. The switch on LEB-100 controls the off/intensity of the numerals on the LEB-140 DSKY and the Mission Timer on LHEB-306. Protection for the integral and numerics circuits is provided by the LIGHTING-NUMERICS/INTEGRAL-LEB AC 2, L MDC AC 1, and R MDC AC 1 circuit breakers on RHEB-226. These circuit breakers are used to disable a circuit in case of a malfunction. The L MDC AC 1 circuit breakers also feed the EMS roll attitude and scroll incandescent lamps.

Tunnel lighting.- The six light fixtures in the CM tunnel provide illumination for tunnel activity during docking and undocking. Each of the fixtures, containing two incandescent lamps, is provided 28 V dc through a TUNNEL LIGHTS-OFF switch on MDC-2 (fig. A2.6-20). Main dc bus A distributes power to one lamp in each fixture, and main dc bus B to the other lamp. Protection is provided by the LIGHTING/COAS/TUNNEL/RNDZ/SPOT MN A and MN B circuit breakers on RHEB-226.

A-78

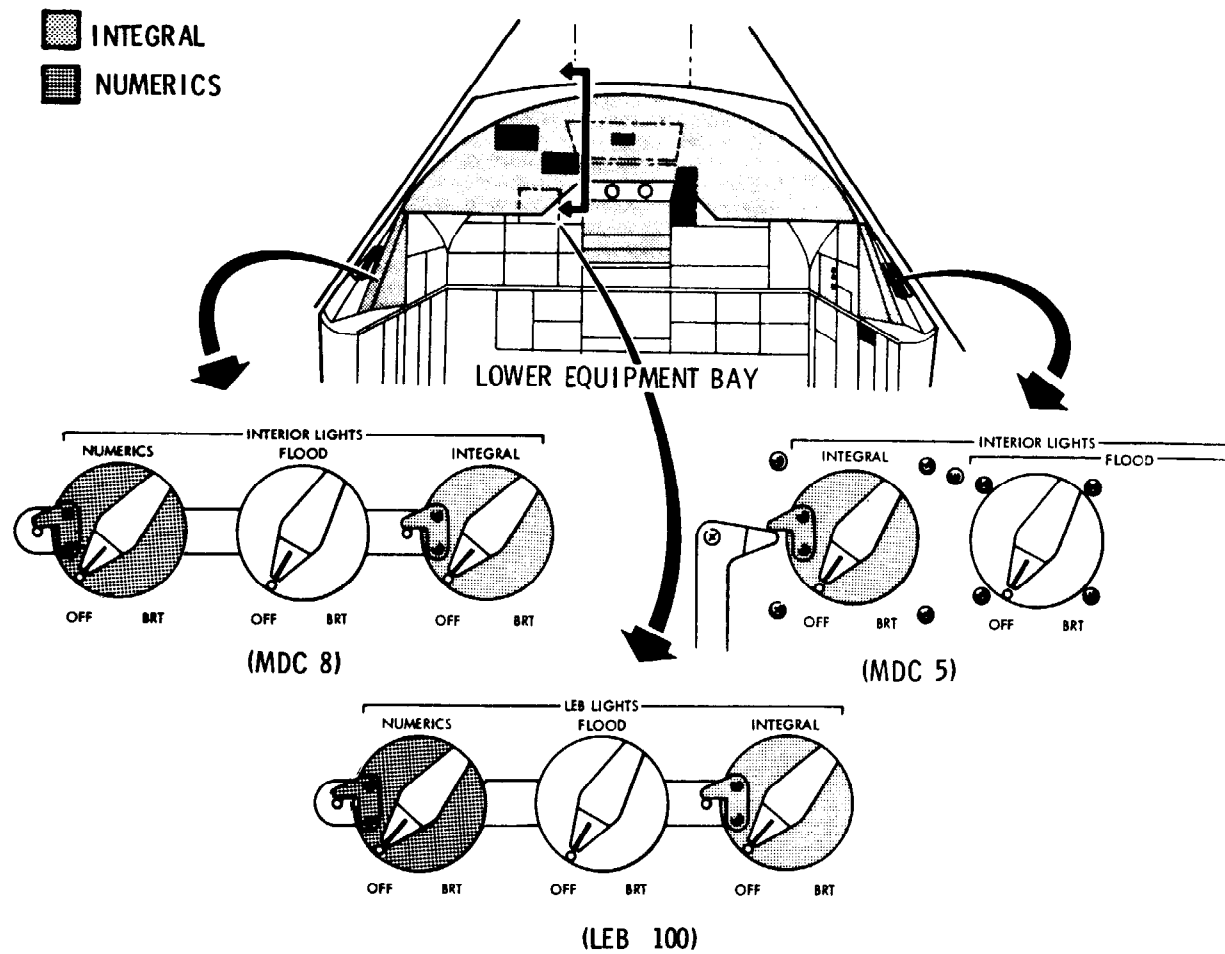

Figure A2.6-18.- CM integral/numerics illumination system.

A-79

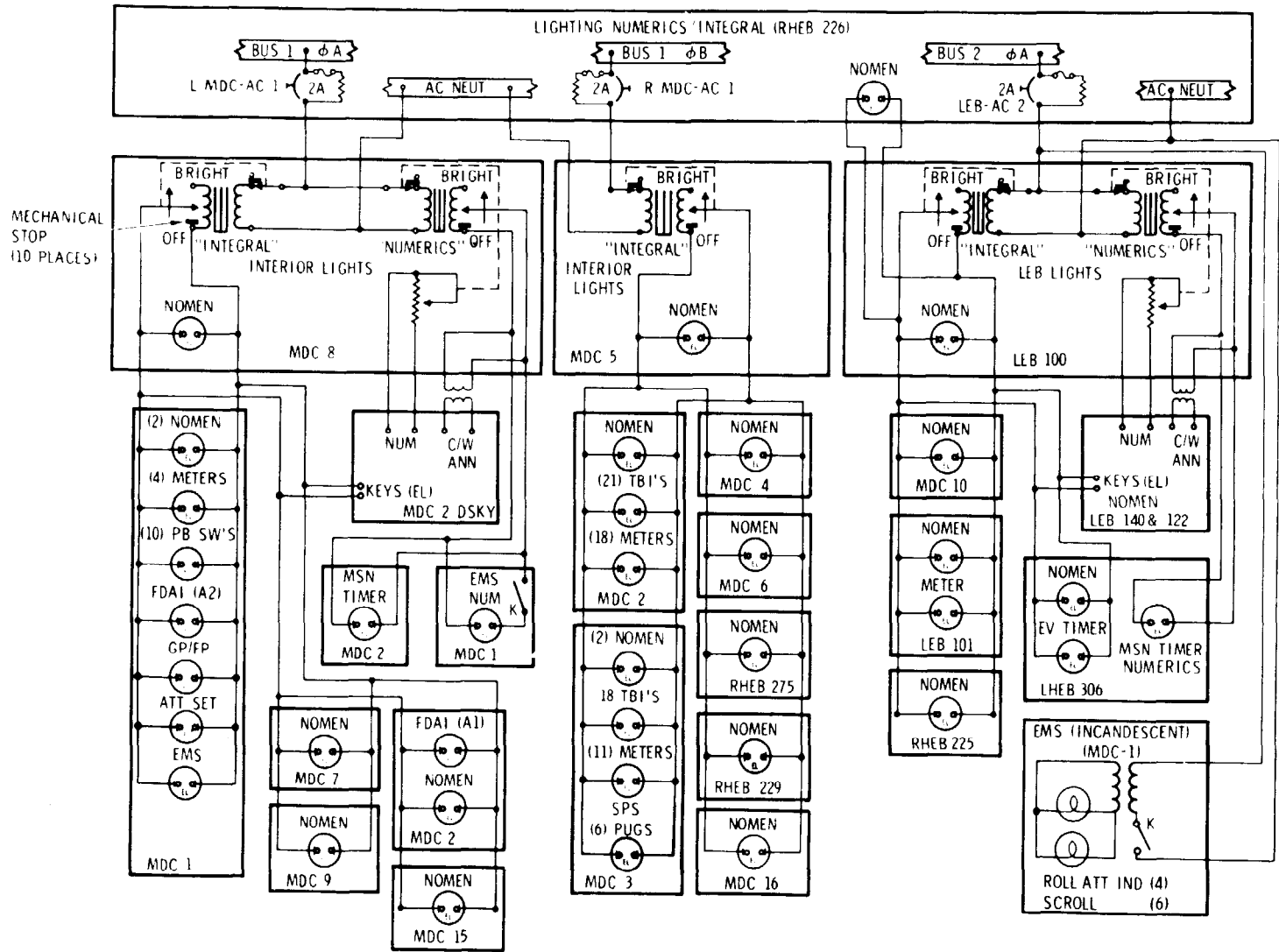

Figure A2.6-19.- Integral and numerics panel lighting schematic.

A-80

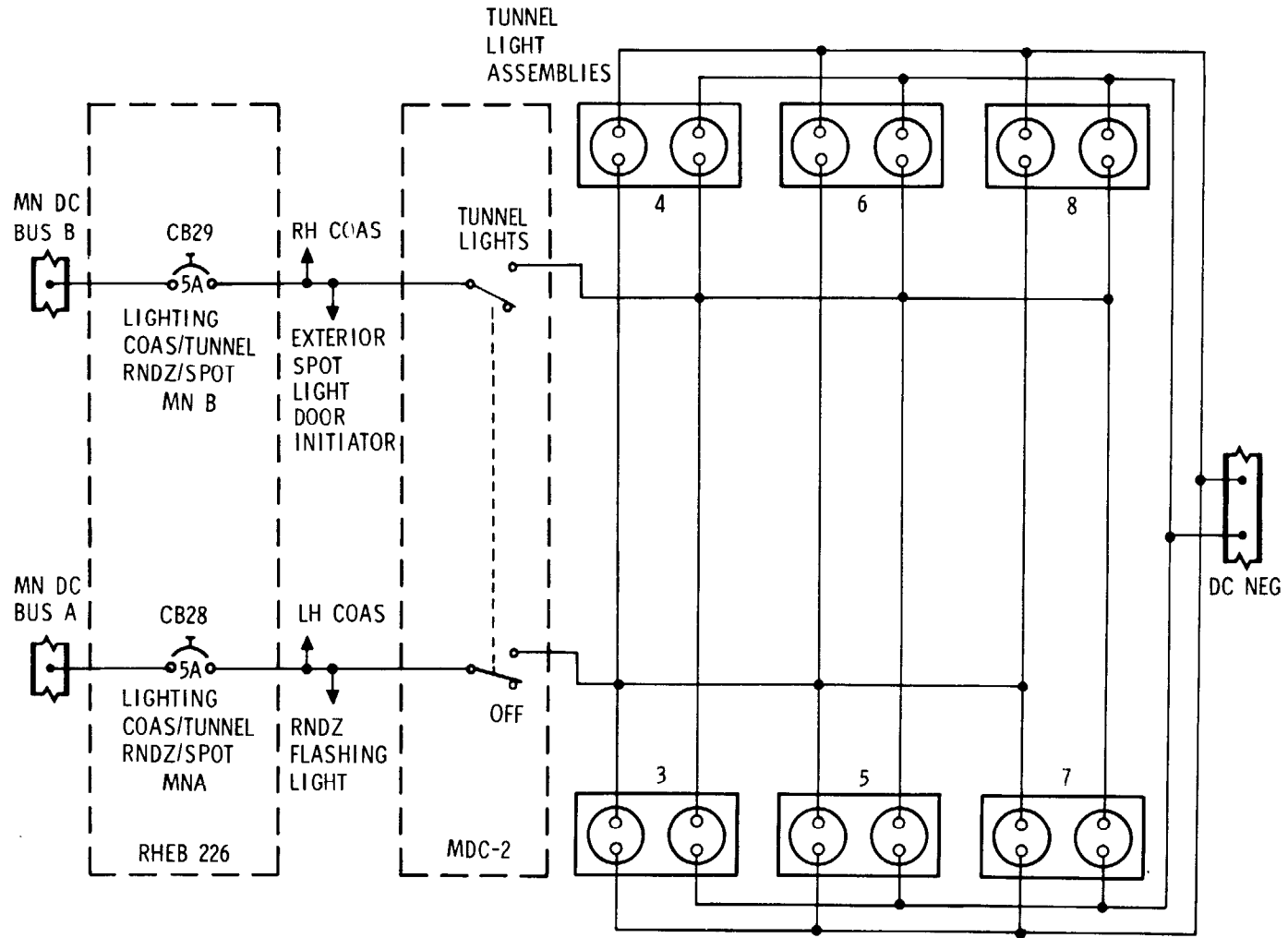

Figure A2.6-20.- Tunnel lighting schematic.

PART A2.7

ENVIRONMENTAL CONTROL SYSTEM

Introduction

The environment control system (ECS) is designed to provide the flight crew with a conditioned environment that is both life-supporting, and as comfortable as possible. The ECS is aided in the accomplishment of this task through an interface with the electrical power system, which supplies oxygen and potable water. The ECS also interfaces with the electronic equipment of the several Apollo systems, for which the ECS provides thermal control, with the lunar module (LM) for pressurizing the LM, and with the waste management system to the extent that the water and the urine dump lines can be interconnected.

The ECS is operated continuously throughout all Apollo mission phases. During this operating period the system provides the following three major functions for the crew:

- a. Spacecraft atmosphere control
- b. Water management
- c. Thermal control.

Control of the spacecraft atmosphere consists of regulating the pressure and temperature of the cabin and suit gases; maintaining the desired humidity by removing excess water from the suit and cabin gases; controlling the level of contamination of the gases by removing CO₂, odors, and particulate matter; and ventilating the cabin after landing. There are provisions for pressurizing the lunar module during docking and subsequent CSM/LM operations.

Water management consists of collecting, sterilizing, and storing the potable water produced in the fuel cells, and delivering chilled and heated water to the crew for metabolic consumption, and disposing of the excess potable water by either transferring it to the waste water system or by dumping it overboard. Provisions are also made for the collection and storage of waste water (extracted in the process of controlling humidity), delivering it to the glycol evaporators for supplemental cooling, and dumping the excess waste water overboard.

Thermal control consists of removing the excess heat generated by the crew and the spacecraft equipment, transporting it to the cab heat exchanger (if required), and rejecting the unwanted heat to space, either by radiation from the space radiators, or in the form of steam by boiling water in the glycol evaporators.

Five subsystems operating in conjunction with each other provide the required functions:

- a. Oxygen subsystem
- b. Pressure suit circuit (PSC)
- c. Water subsystem
- d. Water-glycol subsystem
- e. Postlanding ventilation (PLV) subsystem.

The oxygen subsystem controls the flow of oxygen within the command module (CM); stores a reserve supply of oxygen for use during entry and emergencies; regulates the pressure of oxygen supplied to the subsystem and PSC components; controls cabin pressure in normal and emergency (high flow-rate) modes; controls pressure in the water tanks and glycol reservoir; and provides for PSC purge via the DIRECT O₂ valve.

The pressure suit circuit provides the crew with a continuously conditioned atmosphere. It automatically controls suit gas circulation, pressure, and temperature; and removes debris, excess moisture, odors, and carbon dioxide from both the suit and cabin gases.

The water subsystem (potable section) collects and stores potable water; delivers hot and cold water to the crew for metabolic purposes; and augments the waste water supply for evaporative cooling. The waste water section collects and stores water extracted from the suit heat exchanger, and distributes it to the water inflow control valves of the evaporators, for evaporative cooling.

The water-glycol subsystem provides cooling for the PSC, the potable water chiller, and the spacecraft equipment; and heating or cooling for the cabin atmosphere.

The postlanding ventilation subsystem provides a means for circulating ambient air through the command module cabin after landing.

Functional Description

The environmental control system operates continuously throughout all mission phases. Control begins during preparation for launch and continues through recovery. The following paragraphs describe the operating modes and the operational characteristic of the ECS from the time of crew insertion to recovery.

Spacecraft atmosphere control.- During prelaunch operations the SUIT CIRCUIT RETURN VALVE is closed; and the DIRECT O₂ valve is opened slightly (approximately 0.2 pound per hour flowrate) to provide an oxygen purge of the PSC. Just before prime crew insertion the O₂ flowrate is increased to 0.6 pound per hour. This flow is in excess of that required for metabolic consumption and suit leakage. This excess flow causes the PSC to be pressurized slightly above the CM cabin. The slight overpressure maintains the purity of the PSC gas system by preventing the cabin gases from entering the PSC.

Any changes made in the pressure or composition of the cabin gas during the prelaunch period is controlled by the ground support equipment through the purge port in the CM side hatch.

As soon as the crew connects into the PSC, the suit gas becomes contaminated by CO₂, odors, moisture, and is heated. The gases are circulated by the suit compressor through the CO₂ and odor absorber assembly where a portion of the CO₂ and odors are removed; then through the heat exchanger, where they are cooled and the excess moisture is removed. Any debris that might get into the PSC is trapped by the debris trap or on felt pads on the upstream side of each LiOH cartridge.

During the ascent, the cabin remains at sea level pressure until the ambient pressure decreases a nominal 6 psi. At that point the CABIN PRESSURE RELIEF valve vents the excess gas overboard, maintaining cabin pressure at 6 psi above ambient. As the cabin pressure decreases, a relief valve in the O₂ DEMAND REGULATOR vents suit gases into the cabin to maintain the suit pressure slightly above cabin pressure.

Sometime after attaining orbit it will be necessary to close the DIRECT O₂ valve to conserve oxygen. (Refer to Volume 2, Apollo Operations Handbook for the procedure.) After the DIRECT O₂ valve is closed, makeup oxygen for the PSC is supplied by the DEMAND REGULATOR when the SUIT CIRCUIT RETURN VALVE is closed or from the cabin via the cabin pressure regulator when the SUIT CIRCUIT RETURN VALVE is open.

Before changing from a suited to a shirtsleeve environment it is necessary to open the SUIT CIRCUIT RETURN VALVE, for the following reasons. When a suit is vented (by removing helmet, gloves, etc.) some of the PSC gases flow into the cabin, which results in contaminating the cabin gas, and in lowering suit pressure relative to cabin pressure. Opening the SUIT CIRCUIT RETURN VALVE allows cabin gas to circulate through the PSC for scrubbing, and tends to equalize the pressure differential between the PSC and cabin. If the valve is not opened, the resultant pressure differential will cause the suit DEMAND REG to dump oxygen into the PSC at a flowrate that will turn on the O₂ FLOW HI warning light. Opening the SUIT CIRCUIT RETURN VALVE will correct this situation.

During normal space operations, the cabin pressure is maintained at a nominal 5 psia by the cabin pressure regulator, at flowrates up to 1.4 pounds of oxygen per hour. In the event a high leak rate develops, the EMERGENCY CABIN PRESSURE regulator will supply oxygen at high flow rates to maintain the cabin pressure above 3.5 psia for more than 5 minutes, providing the leak is effectively no larger than a 1/2-inch hole.

When performing depressurized operations the suit circuit pressure is maintained above 3.5 psia by the O₂ DEMAND REGULATOR; the cabin pressure regulator shuts off automatically to prevent wasting oxygen.

Prior to entry SUIT CIRCUIT RETURN VALVE is closed, isolating the suit circuit from the cabin; the O₂ DEMAND REGULATOR then controls suit pressure. Cabin pressure is maintained during the descent by the cabin pressure regulator until the ambient pressure rises to a maximum of 0.9 psi above cabin pressure. At that point the cabin relief valve will open, allowing ambient air to flow into the cabin. As the cabin pressure increases, the O₂ DEMAND REGULATOR admits oxygen into the suit circuit to maintain the suit pressure slightly below the cabin, as measured at the suit compressor inlet manifold.

After spacecraft landing, the cabin is ventilated with ambient air by postlanding ventilation fan and valves. When the CM is floating upright in the water, the POST LANDING VENT switch is placed in the HIGH (day) or LOW (night) position. Either of these positions will supply power to open both vent valves and start the fan. In the HIGH position, the fan will circulate 150 cubic feet per minute (cfm); LOW, 100 cfm. An attitude sensing device automatically closes both valves and removes power from the fan motor when the CM X axis rotates more than 60 degrees from vertical. Once the device is triggered, it will remain locked up until the CM is upright, and the POST LANDING VENT switch is placed in the OFF position. This action resets the control circuit for normal system operation. The PLVC switch on panel 376 provides an override

control for opening the PLV valves and turning on the fan in case the attitude sensor is locked up and cannot be reset; or when the CM is inverted and egress must be made through the tunnel hatch. In either case the POST LANDING VENT switch must be in the LOW or HIGH position.

Water management.- In preparing the spacecraft for the mission, the potable and waste water tanks are partially filled to insure an adequate supply for the early stages of the mission. From the time the fuel cells are placed in operation until CSM separation, the fuel cells replenish the potable water supply. A portion of the water is chilled and made available to the crew through the drinking fixture and the food preparation unit. The remainder is heated, and is delivered through a separate valve on the food preparation unit.

From the time the crew connects into the suit circuit until entry, the water accumulator pumps are extracting water from the suit heat exchanger and pumping it into the waste water system. The water is delivered to the glycol evaporators through individual water control valves. Provision is made for dumping excess waste water manually when the tank is full.

A syringe injection system is incorporated to provide for periodic injection of bactericide to kill bacteria in the potable water system.

Thermal control.- Thermal control is provided by two water-glycol coolant loops (primary and secondary). During prelaunch operations ground servicing equipment cools the water-glycol and pumps it through the primary loop, providing cooling for the electrical and electronic equipment, and the suit and cabin heat exchangers. The cold water-glycol is also circulated through the reservoir to make available a larger quantity of coolant for use as a heat sink during the ascent. Additional heat sink capability is obtained by selecting maximum cooling on the CABIN TEMP selector, and placing both cabin fans in operation. This cold soaks the CM interior structure and equipment. Shortly before launch, one of the primary pumps is placed in operation, the pump in the ground servicing unit is stopped, and the unit is isolated from the spacecraft system.

During the ascent, the radiators will be heated by aerodynamic friction. To prevent this heat from being added to the CM thermal load, the PRIMARY GLYCOL TO RADIATORS valve is placed in the PULL TO BYPASS position at approximately 75 seconds before launch. The coolant then circulates within the CM portion of the loop.

The heat that is generated in the CM, from the time that the ground servicing unit is isolated until the spacecraft reaches 110K feet, is absorbed by the coolant and the prechilled structure. Above 110K feet

it is possible to reject the excess heat by evaporating water in the primary glycol evaporator.

After attaining orbit the reservoir is isolated from the loop to maintain a reserve quantity of coolant for refilling the primary loop in case of loss of fluid by leakage. The PRIMARY GLYCOL TO RADIATORS valve is placed in the position (control pushed in) to allow circulation through the radiators and the radiator outlet temperature sensors. If the radiators have cooled sufficiently (radiator outlet temperature is less than the inlet) they will be kept on-stream; if not, they will be bypassed until sufficient cooling has taken place. After the radiators have been placed on-stream, the glycol temperature control is activated (GLYCOL EVAP TEMP IN switch in AUTO); and the CABIN TEMP selector is positioned as desired.

The primary loop provides thermal control throughout the mission unless a degradation of system performance requires the use of the secondary loop.

Several hours before CM-SM separation the system valves are positioned so that the primary loop provides cooling for the cabin heat exchanger, the entire cold plate network, and the suit heat exchanger. The CABIN TEMP control valve is placed in the MAX COOL position, and both cabin fans are turned on to cold-soak in the CM interior structure.

Prior to separation the PRIMARY GLYCOL TO RADIATORS, and the GLYCOL TO RADIATORS SEC valves are placed in the BYPASS position to prevent loss of coolant when the CSM umbilical is cut. From that time (until approximately 110K feet spacecraft altitude) cooling is provided by water evaporation.

Oxygen Subsystem

The oxygen subsystem shares the oxygen supply with the electrical power system. Approximately 640 pounds of oxygen is stored in two cryogenic tanks located in the service module. Heaters within the tanks pressurize the oxygen to 900 psig for distribution to the using equipment.

Oxygen is delivered to the command module through two separate supply lines, each of which is connected to an oxygen inlet restrictor assembly. Each assembly contains a filter, a capillary line, and a spring-loaded check valve. The filters provide final filtration of gas entering the CM. The capillaries which are wound around the hot glycol line serve two purposes; they restrict the total O₂ flow rate to a maximum of 9.0 pounds per hour, and they heat the oxygen entering the CM. The check valves serve to isolate the two supply lines.

Downstream of the inlet check valves the two lines tee together and a single line is routed to the OXYGEN-S/M SUPPLY valve on panel 326. This valve is used in flight as a shutoff valve to back up the inlet check valves during entry. It is closed prior to CM-SM separation.

PART A2.8
TELECOMMUNICATIONS SYSTEM

Introduction

The communications subsystem is the only link between the spacecraft and the manned space flight network (MSFN). In this capacity, the communications subsystem provides the MSFN flight controllers with data through the pulse code modulated (PCM) telemetry system for monitoring spacecraft parameters, subsystem status, crew biomedical data, event occurrence, and scientific data. As a voice link, the communications subsystem gives the crew the added capability of comparing and evaluating data with MSFN computations. The communications subsystem, through its MSFN link, serves as a primary means for the determination of spacecraft position in space and rate of change in position. CM-LM rendezvous is facilitated by a ranging transponder and an active ranging system. Through the use of television camera, crew observations and public information can be transmitted in real time to MSFN. A means by which CM and LM telemetry and voice can be stored in the spacecraft for later playback, to avoid loss because of an interrupted communications link, is provided by the communications subsystem in the form of the data storage equipment (DSE). Direction-finding aids are provided for postlanding location and rescue by ground personnel.

The following list summarizes the general telecomm functions:

- a. Provide voice communication between:
 - (1) Astronauts via the intercom
 - (2) CSM and MSFN via the unified S-band equipment (USBE) and in orbital and recovery phases via the VHF/AM
 - (3) CSM and extravehicular astronaut (EVA) via VHF/AM
 - (4) CSM and LM via VHF/AM
 - (5) CSM and launch control center (LCC) via PAD COMM
 - (6) CSM and recovery force swimmers via swimmers umbilical
 - (7) Astronauts and the voice log via intercomm to the data storage equipment

- b. Provide data to the MSFN of :
 - (1) CSM system status
 - (2) Astronaut biomedical status
 - (3) Astronaut activity via television
 - (4) EVA personal life support system (PLSS) and biomed status
 - (5) LM system status recorded on CSM data storage equipment
- c. Provide update reception and processing of:
 - (1) Digital information for the command module computer (CMC)
 - (2) Digital time-referencing data for the central timing equipment (CTE)
 - (3) Real-time commands to remotely perform switching functions in three CM systems
- d. Facilitate ranging between:
 - (1) MSFN and CSM via the USBE transponder
 - (2) LM and CSM via the rendezvous radar transponder (RRT)
 - (3) CSM and LM via the VHF/AM ranging system
- e. Provide a recovery aid VHF for spacecraft location.
- f. Provide a time reference for all time-dependent spacecraft subsystems except the guidance and navigation subsystem.

Functional Description

The functional description of the telecommunications system is divided into four parts: intercommunications equipment, data equipment, radio frequency equipment, and antenna equipment. All of these functional groups of equipment interface with each other to perform the system tasks. In the functional descriptions of these parts, such interfaces will be apparent.

PART A2.9

SEQUENTIAL SYSTEMS

Introduction

Sequential systems include certain detection and control subsystems of the launch vehicle (LV) and the Apollo spacecraft (SC). They are utilized during launch preparations, ascent, and entry portions of a mission, preorbital aborts, early mission terminations, docking maneuvers, and SC separation sequences. Requirements of the sequential systems are achieved by integrating several subsystems. Figure A2.9-1 illustrates the sequential events control subsystem (SECS), which is the nucleus of sequential systems, and its interface with the following subsystems and structures:

- a. Displays and controls
- b. Emergency detection (EDS)
- c. Electrical power (EPS)
- d. Stabilization and control (SCS)
- e. Reaction control (RCS)
- f. Docking (DS)
- g. Telecommunications (T/C)
- h. Earth landing (ELS)
- i. Launch escape (LES)
- j. Structural

Sequential Events Control Subsystem

The SECS is an integrated subsystem consisting of 12 controllers which may be categorized in seven classifications listed as follows:

- a. Two master events sequence controllers (MESC)
- b. Two service module jettison controllers (SMJC)

- c. One reaction control system controller (RCSC)
- d. Two lunar module (LM) separation sequence controllers (LSSC)
- e. Two lunar docking events controllers (LDEC)
- f. Two earth landing sequence controllers (ELSC)
- g. One pyro continuity verification box (PCVB)

Five batteries and three fuel cells are the source of electrical power. The SMJC is powered by fuel cells; however, battery power is used for the start signal. The RCSC is powered by the fuel cells and batteries. The remaining controllers of the SECS are powered by batteries exclusively.

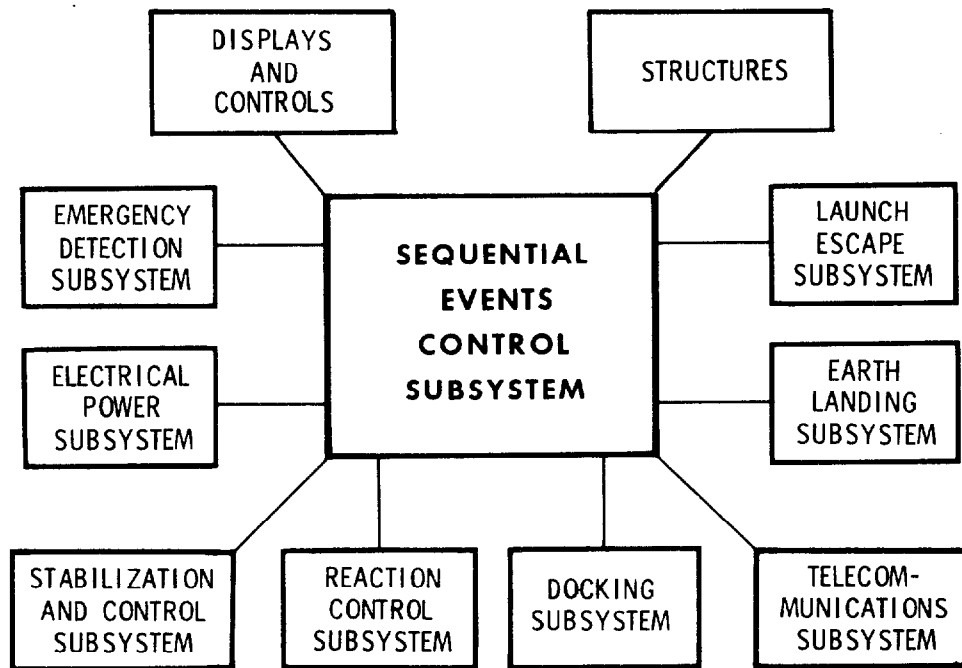

Figure A2.9-1.- SECS interface.

Origin of Signals

The SECS receives manual and/or automatic signals and performs control functions for normal mission events or aborts. The manual signals are the result of manipulating switches on the main display console (MDC) or rotating the Commander's translation hand control counterclockwise, which is the prime control for a manual abort. Automatic abort signals are relayed by the emergency system (EDS).

PART A2.10

CAUTION AND WARNING SYSTEM

Introduction

The caution and warning system (C&WS) monitors critical parameters of most of the systems in the CM and SM. When a malfunction or out-of-tolerance condition occurs in any of these systems, the crew is immediately alerted in order that corrective action may be taken.

Functional Description

Upon receipt of malfunction or out-of-tolerance signals, the C&WS simultaneously identifies the abnormal condition and alerts the crew to its existence. Each signal will activate the appropriate systems status indicator and a master alarm circuit. The master alarm circuit visually and aurally attracts the crew's attention by alarm indicators on the MDC and by an audio tone in the headsets. Crew acknowledgment of an abnormal condition consists of resetting the master alarm circuit, while retaining the particular systems status malfunction indication. The capability exists for the crew to select several modes of observing systems status and master alarm indicators and of monitoring CM or SM systems.

Major Component Subsystem Description

The C&WS consists of one major component, the detection unit. It is located behind MDC-3, and therefore is neither visible nor accessible to the crew during the mission. The balance of the system is made up of visual indicators, aural alerting and associated circuits, and those switches required to control the various system functions. Visual indicators include the two uppermost fuel cell electromechanical event devices on MDC-3, as well as all systems status and master alarm lights.

The detection unit circuits consist of comparators, logic, lamp drivers, and a master alarm and tone generator. Also incorporated are two redundant power supplies, a regulated +12 and a -12 V dc for the electronics.

Inputs to the detection unit consist of both analog and event-type signals. The analog signals are in the 0 to 5 V dc range. Alarm limits for these signals trigger voltage comparators, which, in turn, activate logic and lamp-driver circuits, thus causing activation of the master

alarm circuit and tone generator, illumination of applicable systems status lights on MDC-2, and for certain measurements, activation of applicable electromechanical event indicators on MDC-3. Several event inputs are monitored by the C&WS detection unit. These signals originate from solid state and mechanical switch closures in malfunction sensing devices. These signals will directly illuminate applicable system status lights and, through logic circuitry, activate the master alarm lights and tone generator. One event signal, originating within the detection unit, directly illuminates the C/W light, but activates only the MASTER ALARM switch lights of the master alarm circuit. One event signal, "CREW ALERT," originates from MSFN stations through the UDL portion of the communications system. This system status light can only be extinguished by a second signal originating from the MSFN.

The master alarm circuit alerts crewmembers whenever abnormal conditions are detected. This is accomplished visually by illumination of remote MASTER ALARM switch-lights on MDC-1, MDC-3, and LEB-122. An audio alarm tone, sent to the three headsets, aurally alerts the crew. The output signal of the tone generator is a square wave that is alternately 750 and 2000 cps, modulated at 2.5 times per second. Although the tone is audible above the conversation level, it does not render normal conversation indistinct or garbled. When the crew has noted the abnormal condition, the master alarm lights and the tone generator are deactivated and reset by depressing any one of the three MASTER ALARM switch-lights. This action leaves the systems status lights illuminated and resets the master alarm circuit for alerting the crew if another abnormal condition should occur. The individual systems status lights will remain illuminated until the malfunction or out-of-tolerance condition is corrected, or the NORMAL-BOOST-ACK switch (MDC-3) is positioned to ACK.

The C&WS power supplies include sensing and switching circuitry that insure unit self-protection should high-input current, or high- or low-output voltage occur. Any of these fault conditions will cause the illumination of the master alarm lights and the C/W system status light. The tone generator, however, will not be activated because it requires the 12 V dc output from the malfunctioned power supply for its operation. The crew must manually select the redundant power supply to return the C&WS to operation. This is accomplished by repositioning the CAUTION/WARNING-POWER switch on MDC-2. In so doing, the C/W status light is extinguished, but the master alarm circuit remains activated, requiring it to be reset.

Incorporated into the C&WS is the capability to test the lamps of systems status and master alarm lights. Position 1 of the CAUTION/WARNING-LAMP TEST switch tests the illumination of the left-hand group of status lights on MDC-2 and the MASTER ALARM switch-light on MDC-1.

Position 2 tests the MASTER ALARM switch-light on MDC-3 and the right-hand group of status lights on MDC-2. The third MASTER ALARM light, located on LEB-122, is tested by placing the CONDITION LAMPS switch on LEB-122 to TEST.

The position of the CAUTION/WARNING - CSM-CM switch (MDC-2) establishes the systems to be monitored. Before CM-SM separation, systems in both the CM and SM are monitored for malfunction or out-of-tolerance conditions with this switch in the CSM position. Positioning the switch to CM deactivates systems status lights and event indicators associated with SM systems.

The CAUTION/WARNING - NORMAL-BOOST-ACK switch (MDC-2) permits variable modes of status and alarm light illumination. For most of the mission, the switch is set to the NORMAL position to give normal C&WS operation; that is, upon receipt of abnormal condition signals, all systems status lights and master alarm lights are capable of illumination. During the ascent phase, the switch is set to the BOOST position, which prevents the MASTER ALARM switch-light on MDC-1 from illuminating. This prevents possible confusion on MDC-1 between the red MASTER ALARM light and the adjacent red ABORT light. The ACK switch position is selected when the crew desires to adapt their eyes to darkness, or if a continuously illuminated systems status light is undesirable. While in this mode, incoming signals will activate only the master alarm lights and the tone generator. To determine the abnormal condition, the crew must depress either MASTER ALARM switch-light on MDC-1 or -3. This illuminates the applicable systems status light, and deactivates and resets the master alarm circuit. The systems status light will remain illuminated as long as the switch-light is depressed. However, it may be recalled as long as the abnormal condition exists by again pressing either switch-light.

A stowable tone booster is added to the caution and warning system to allow all three astronauts to sleep simultaneously with the headsets removed. Stowage of this unit during non-use periods is under locker A3.

The unit consists of a power plug, tone booster, and a photo-sensitive device which can be used on the left or right side of the command module. The power connection is made to the UTILITY receptacle on MDC-15 or 16. The tone booster, which provides an audible signal, is mounted by velcro pad to the left-hand or right-hand girth shelf. The photo-sensitive device is mounted by velcro over the MDC-1 or MDC-3 MASTER ALARM lamp.

Since the MASTER ALARM is triggered by any caution/warning monitored symptom, it will activate the tone booster until the

MASTER ALARM is extinguished by a manual reset. In the event of a caution/warning system power supply failure, this unit will provide the audio alarm.

Electrical power distribution.- The C&WS receives power from the MNA & MNB buses (see fig. A2.10-1). Two circuit breakers, located on MDC-5, provide circuit protection. Closure of either circuit breaker will allow normal system operation.

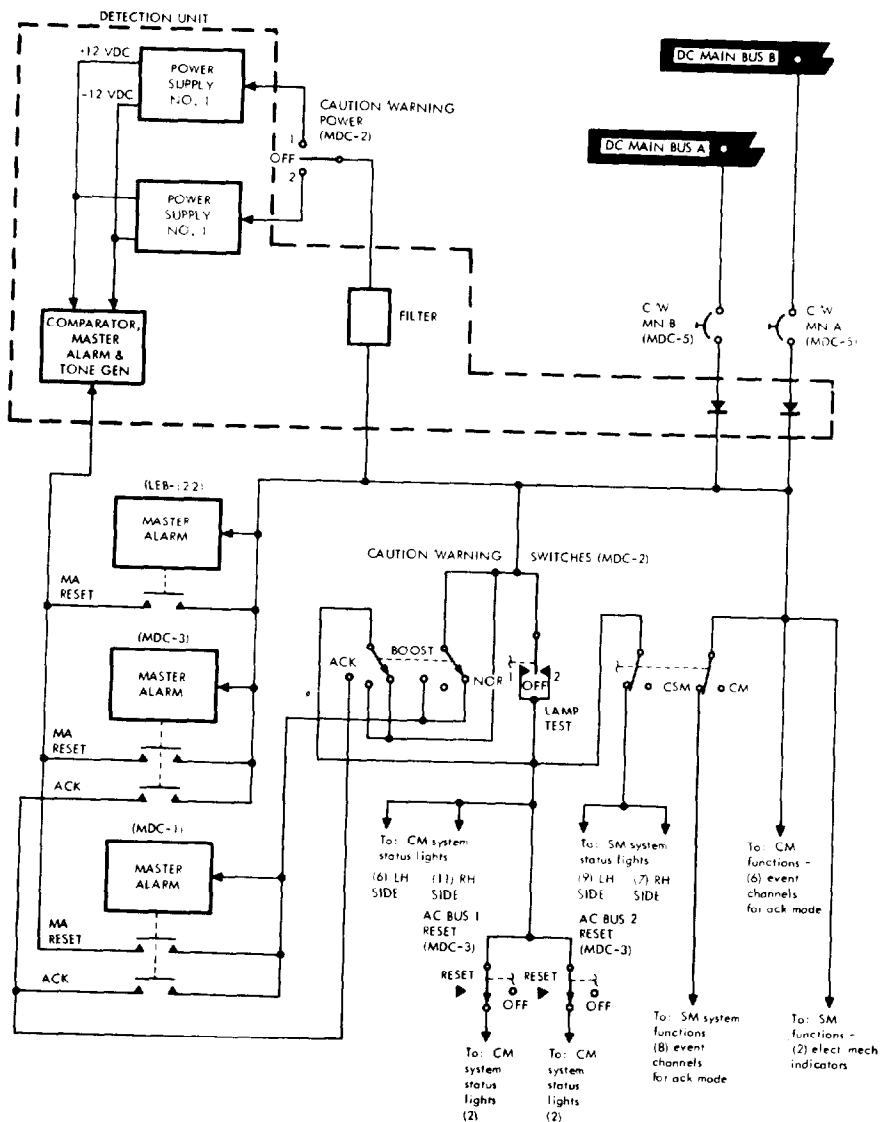

Figure A2.10-1.- C&WS power distribution diagram.

Operational Limitations and Restrictions

With the CAUTION/WARNING - NORMAL-BOOST-ACK switch in the BOOST position during ascent, the MASTER ALARM switch-light on MDC-1 will not illuminate should a malfunction occur. The master alarm circuit reset capability of the light is also disabled during this time. This requires the MASTER ALARM switch-light on MDC-3 to be used exclusively for monitoring and resetting functions during boost. Several peculiarities should be noted in regard to the CAUTION/WARNING - POWER switch. Whenever this switch is moved from or through the OFF position to either power supply position, the master alarm circuit is activated, requiring it be reset. Also, switching from one power supply to another (when there is no power supply failure) may cause the C/W system status light to flicker as the switch passes through the OFF position.

Should both power supplies fail, the C&WS is degraded to the extent that the complete master alarm circuit, as well as those system status lights that illuminate as the result of analog-type input signals, are rendered inoperative. This leaves only those status lights operative that require event-type input signals. They include the following SM and CM lights: CMC, ISS, BMAG 1 TEMP, BMAG 2 TEMP, SPS ROUGH ECO, PITCH GMBL 1, PITCH GMBL 2, YAW CMBL 1, YAW GMBL 2, O₂ FLOW HI, FC BUS DISCONNECT, AC BUS 1, AC BUS 1 OVERLOAD, AC BUS 2, AC BUS 2 OVERLOAD, MN BUS A UNDERVOLT, MN BUS B UNDERVOLT, and CREW ALERT. The C/W light will be operative only while the CAUTION/WARNING - POWER switch is in position 1 or 2.

The CAUTION/WARNING - CSM-CM switch must be in the CSM position in order to conduct a lamp test of those system status lights associated with SM systems. The status lights of CM systems may be tested with the switch in either position. Circuit design permits a complete lamp test to be conducted with the CAUTION/WARNING switch in the NORMAL or ACK position only. In the BOOST position, all lamps except the MASTER ALARM light on MDC-1 may be tested.

Normally, each abnormal condition signal will activate the C&WS master alarm circuit and tone generator, and illuminate the applicable systems status light. However, after initial activation of any status light that monitors several parameters, and reset of the MASTER ALARM, any additional out-of-tolerance condition or malfunction associated with the same system status light will not activate the MASTER ALARM until the first condition has been corrected, thus extinguishing the status light.

Each crewmember's audio control panel has a power switch which will allow or inhibit the tone signal from entering his headset. The AUDIO-TONE position allows the signal to pass on to the headset, while the AUDIO position inhibits the signal.

PART A2.11

MISCELLANEOUS SYSTEMS DATA

Introduction

Miscellaneous systems data pertain to items that are not covered in other systems. These items consist of timers, accelerometers (G-meter), and uprighting system.

Timers

Two mission timers (electrical) and two event timers (electrical/mechanical) are provided for the crew in the command module. One mission timer is located on panel 2 of the MDC and the other on panel 306 in the left-hand forward equipment bay. Each mission timer has provisions for manually setting the readout (hours, minutes, and seconds), and the capability of starting, stopping, and resetting to zero. The numerical elements are electroluminescent lamps and the intensity is controlled by the NUMERICS light control on panels MDC-8 and LEB-100. The event timers are located on MDC-1 and -306 in the left-hand forward equipment bay, and provide the crew with a means of monitoring and timing events. All timers reset and start automatically when lift-off occurs, and the timer located on MDC-1 will be automatically reset and restarted if an abort occurs. The event timers are integrally illuminated by an internal electroluminescent lamp and controlled by the INTEGRAL light controls located on MDC-8 and LEB-100.

Accelerometer (G-meter)

The accelerometer or G-meter (MDC-1) provides the crew with a visual indication of spacecraft positive and negative G-loads. This meter is illuminated by an internal electroluminescent lamp and controlled by the INTEGRAL light control on MDC-8.

Command Module Uprighting System

The CM uprighting system is manually controlled and operated after the CM has assumed a stable, inverted floating attitude. The system consists of three inflatable air bags, two relays, three solenoid-control valves, two air compressors, control switches, and air lines. The inflatable bags are located in the CM forward compartment and the air compressors in the aft compartment. The control switches and circuit breakers are

located in the crew compartment. The switches control relays which are powered by the postlanding bus and the relays control power to the compressors which are powered by battery buses A and B. (See figure A2.11-1.)

A-101

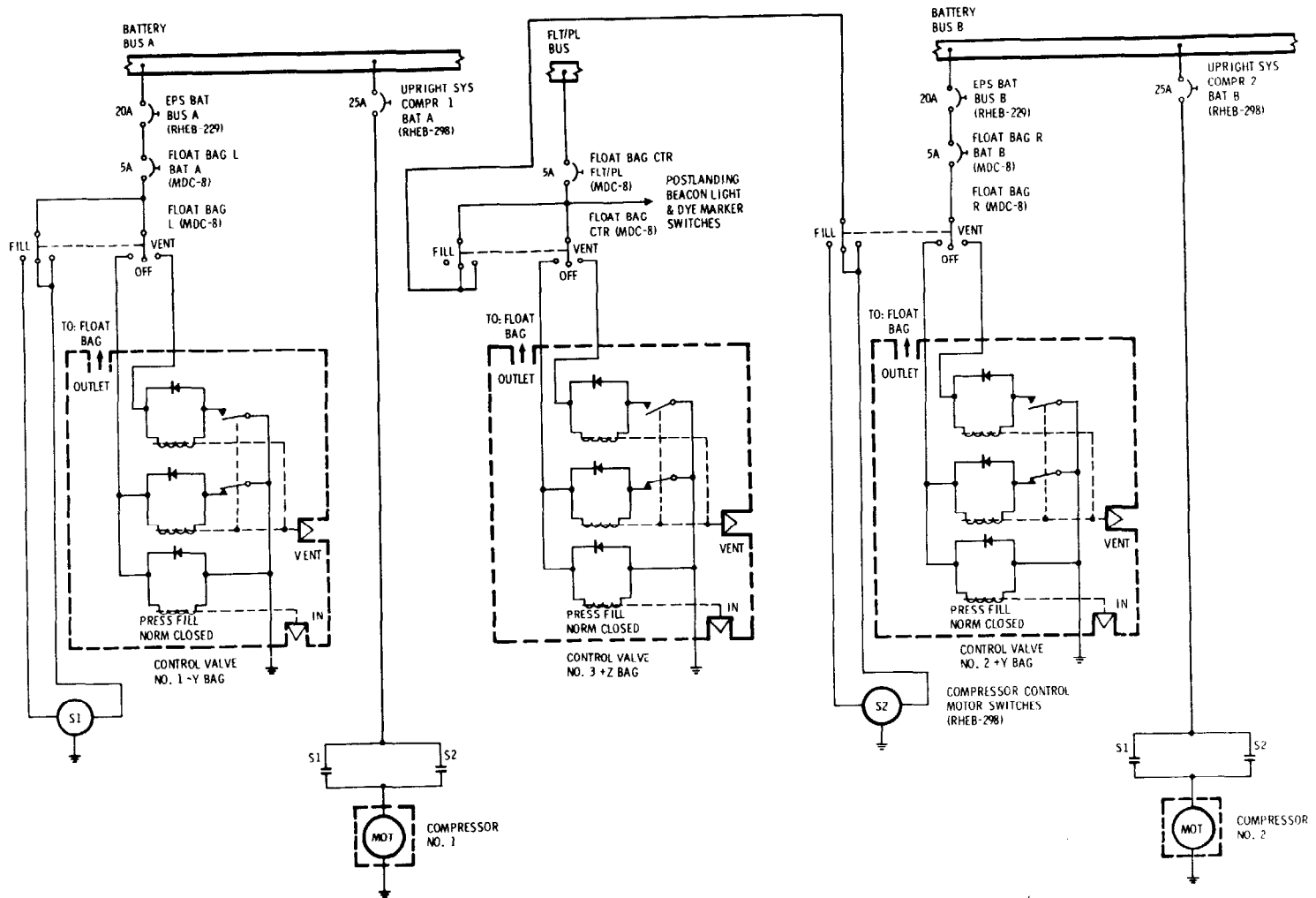

Figure A2.11-1.- Sequential systems operational/functional diagram.

Functional description.- FLOAT BAG 1L switch controls inflation of the air bag on -Y axis, switch 2R controls inflation of the air bag on the +Y axis, and switch 3 CTR controls inflation of the air bag on the +Z axis of the CM (see fig. A2.11-1). Two of the bags are 45 inches in diameter; the other bag is 24 inches in diameter. If the CM becomes inverted after landing, the crewmember at station 1 initiates filling of the three bags by setting the FLOAT BAG 1L, 2R, and 3 CTR switches to FILL. When the CM is uprighted, the three FLOAT BAG switches will be set to OFF. A 4.25 ± 0.25 -psi relief valve is located in the inlet of each bag. Backup relief valves set at 13.5 psi are located in the outlet of each compressor.

PART A2.12

CREW PERSONAL EQUIPMENT

This section contains the description and operation of Contractor- and NASA-furnished crew personal equipment and miscellaneous stowed equipment that is not described in other sections of the handbook. All major items are identified as Contractor-furnished equipment (CFE) or Government-furnished (NASA) property (GFP - synonymous with GFE).

The crew equipment is presented in the general order of operational usage in SM2A-03-BLOCK. A brief outline is as follows:

- a. Spacesuits
 - (1) Intravehicular Spacesuit Assembly
 - (a) Biomedical Harness and Belt
 - (b) Constant Wear Garment (CWG)
 - (c) Flight Coveralls
 - (d) Pressure Garment Assembly (PGA)
 - (e) Associated Umbilicals, Adapters, and Equipment
 - (2) Extravehicular Spacesuit Assembly
 - (a) Liquid-Cooled Garment (LCG)
 - (b) PGA with Integrated Thermal Meteoroid Garment (ITMG)
 - (c) Associated Equipment
- b. G-Load Restraints
 - (1) Crewman Restraint Harness
 - (2) Interior Handhold and Straps
 - (3) Hand Bar
- c. Zero-g Restraints
 - (1) Rest Stations
 - (2) Velcro and Snap Restraint Areas
 - (3) Straps

- d. Internal Sighting and Illumination Aids
 - (1) Window Shades
 - (2) Mirrors
 - (3) Crewman Optical Alignment Sight (COAS)
 - (4) LM Active Docking Target
 - (5) Window Markings
 - (6) Miscellaneous Aids

- e. External Sighting and Illumination Aids
 - (1) Exterior Spotlight
 - (2) Running Lights
 - (3) EVA Floodlight
 - (4) EVA Handles with RL Disks
 - (5) Rendezvous Beacon

- f. Mission Operational Aids
 - (1) Flight Data File
 - (2) Inflight Toolset
 - (3) Cameras
 - (4) Accessories & Miscellaneous
 - (a) Waste Bags
 - (b) Pilot's Preference Kits (PPKs)
 - (c) Fire Extinguishers
 - (d) Oxygen Masks
 - (e) Utility Outlets
 - (f) Scientific Instrumentation Outlets

- g. Crew Life Support
 - (1) Water
 - (2) Food

- (3) The Galley System
- (4) Waste Management System
- (5) Personal Hygiene
- h. Medical Supplies and Equipment
- i. Radiation Monitoring and Measuring Equipment
- j. Postlanding Recovery Aids
 - (1) Postlanding Ventilation Ducts
 - (2) Swimmer Umbilical and Dye Marker
 - (3) Recovery Beacon
 - (4) Snagging Line
 - (5) Seawater Pump
 - (6) Survival Kit
- k. Equipment Stowage

PART A2.13

DOCKING AND TRANSFER

Introduction

This section identifies the physical characteristics of the docking system and the operations associated with docking and separation.

Docking operational sequence.- The following sequence of illustrations and text describe the general functions that are performed during docking. These activities will vary with the different docking modes.

After the spacecraft and third stage have orbited the earth, possibly up to three revolutions, the third stage is reignited to place the spacecraft on a translunar flight.

Shortly after translunar injection, the spacecraft transposition and docking phase takes place (fig. A2.13-1). When the CSM is separated from the third stage, docking is achieved by maneuvering the CSM close enough so that the extended probe (accomplished during earth orbit) engages with the drogue in the LM. When the probe engages the drogue with the use of the capture latches, the probe retract system is activated to pull the LM and CSM together.

Upon retraction, the LM tunnel ring will activate the 12 automatic docking ring latches on the CM and effect a pressure seal between the modules through the two seals in the CM docking ring face. After the two vehicles are docked, the pressure in the tunnel is equalized from the CM through a pressure equalization valve. The CM forward hatch is removed and the actuation of all 12 latches is verified. Any latches not automatically actuated will be cocked and latched manually by the crewman. The LM to CM electrical umbilicals are retrieved from their stowage position in the LM tunnel and connected to their respective connectors in the CM docking ring.

The vehicle umbilicals supply the power to release the LM from the SLA. Once the hold-down straps are severed, four large springs located at each attachment point push the two vehicles apart, and the combined CSM/LM continues towards the moon.

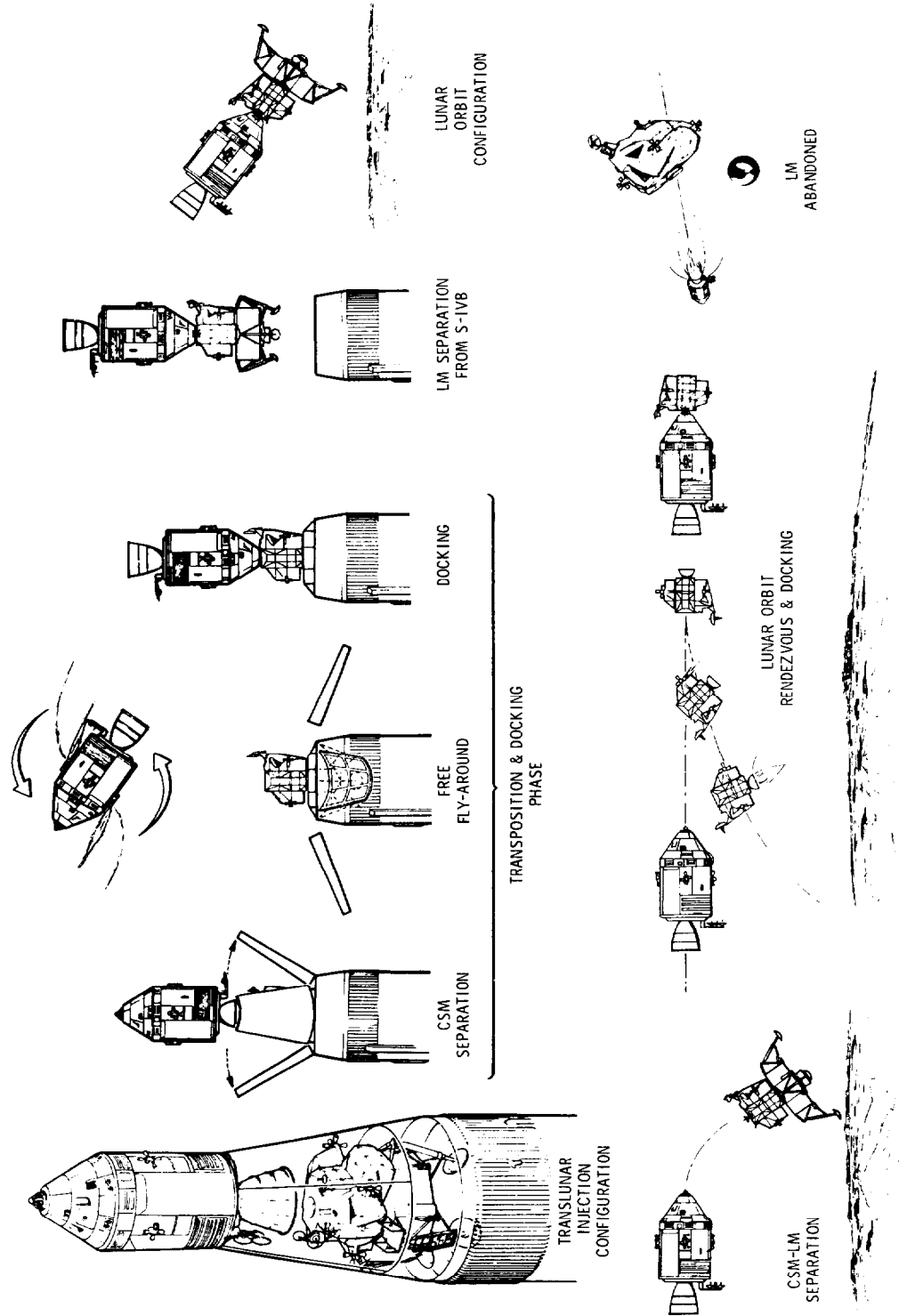

Figure A2.13-1.- CSM/LM docking operational phases.

Once in lunar orbit, the tunnel is repressurized. The probe assembly and drogue assembly are removed from the tunnel and stowed in the CM. The pressure in the LM is equalized through the LM hatch valve. With the pressure equalized, the LM hatch is opened and locked in the open position to provide a passageway between the two modules.

After two crewmen transfer to the LM, the CM crewman retrieves the drogue from its stowage location in the CM, passes it through the tunnel, and helps to install and lock it in the tunnel. The drogue may be installed and locked by the LM crewmen, if they choose. The probe assembly is then retrieved from its stowage location in the CM and installed and preloaded to take all the load between the modules. This accomplished, the LM hatch is closed by the LM crewmen. The 12 docking latches are released and cocked by the crewman in the CM so that the latches are ready for the next docking operation. The CM forward hatch is reinstalled and checked to assure a tight seal. The modules are now prepared for separation.

The probe EXTEND RELEASE/RETRACT switch in the CM (MDC-2) is placed in the EXTEND position, energizing the probe extend latch. The probe extends and during extension will activate a switch energizing an internal electrical motor to unlock the capture latches. After the probe extends, the LM pulls away from the CM and descends to the lunar surface. If the switch is not held until the probe reaches full extension, the capture latches will reengage to hold the two vehicles together. The switch would then have to be reactivated and separation performed with the RCS.

After landing, it will be several hours before the first man steps foot on the moon. The first few hours are spent checking the LM ascent stage and resting. This completed, the cabin is depressurized and one of the crewmen descends to the lunar surface. Following a short period, the second crewman descends to the surface. Lunar surface activities will vary for each mission.

Following completion of the lunar surface exploration the ascent engine is fired using the depleted descent stage as a launch platform.

After rendezvous and docking in lunar orbit, the LM crewmen transfer back to the CM. After the CSM and LM pressures have equalized, the LM crew opens the LM hatch while the CM pilot removes the tunnel hatch. The drogue and probe are removed and stowed in the LM. Lunar samples, film, and equipment to be returned to earth are transferred from the LM to the CM. Equipment in the CM that is no longer needed is put into the LM, and the LM hatch is closed, the CM hatch is replaced, and the seal checked.

The LM is then released by firing the separation system (detonating cord) located around the circumference of the docking ring, thus serving the ring and abandoning the LM (fig. A2.13-1). This completed, the CM SPS engine is fired, placing the spacecraft in a return trajectory toward the earth.

Functional Description

The docking system is a means of connecting and disconnecting the LM/CSM during a mission and is removable to provide for intravehicular transfer between the CSM and LM of the flight crew and transferrable equipment.

The crew transfer tunnel, or CSM/LM interlock area, is a passageway between the CM forward bulkhead and the LM upper hatch. The hatch relationship with the docking hardware is shown in fig. A2.13-2. (The figure does not show the installed positions.) For descriptive purposes that portion of the interlock area above the CM forward bulkhead to the docking interface surface is referred to as the CM tunnel. That portion of the interlock outboard of the LM upper hatch extending to the docking interface surface is referred to as the LM tunnel. The CM tunnel incorporates the CM forward hatch, probe assembly, docking ring and seals, and the docking automatic latches. The LM tunnel contains a hinged pressure hatch, drogue support fittings, drogue assembly, drogue locking mechanism, and LM/CM electrical umbilicals.

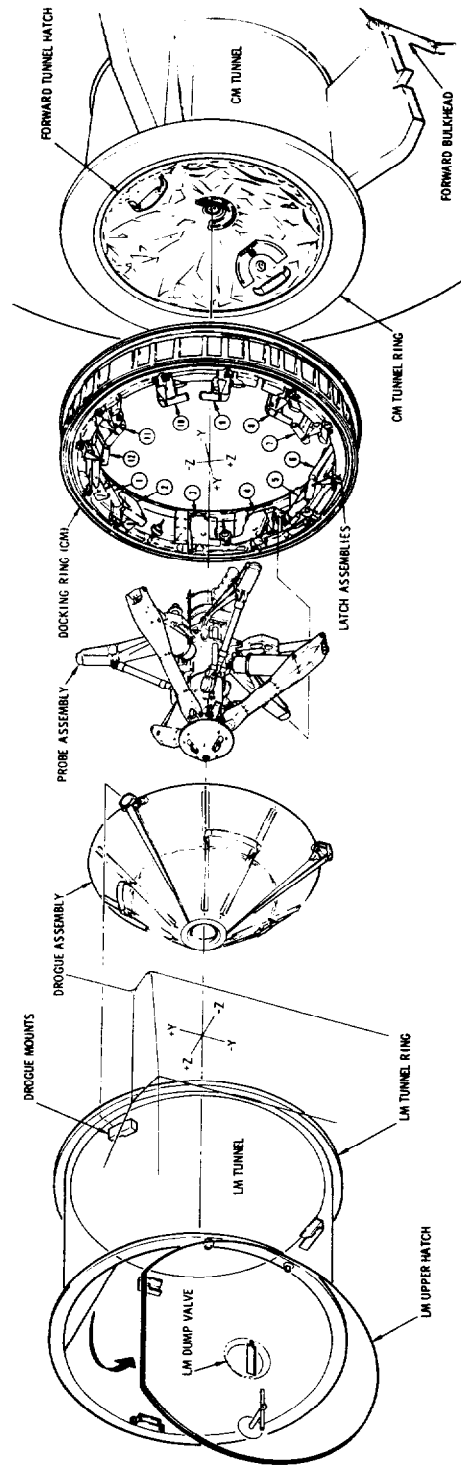

Figure A2.13-2.- Docking system.

PART A3

LUNAR MODULE SYSTEMS DESCRIPTION

INTRODUCTION

This part includes descriptions of the LM, the LM - spacecraft-to-lunar module adapter (SLA) - S-IVB connections, the LM-CSM interfaces, and LM stowage provisions are included in this chapter. These data were extracted from the technical manual LMA 790-3-LM, Apollo Operations Handbook, Lunar Module, Volume 1, dated February 1, 1970.

LM CONFIGURATION

The LM (fig. A3-1) is designed for manned lunar landing missions. It consists of an ascent stage and a descent stage; the stages are joined together at four interstage fittings by explosive nuts and bolts. Subsystem continuity between the stages is accomplished by separable interstage umbilicals and hardline connections.

Both stages function as a single unit during lunar orbit, until separation is required. Stage separation is accomplished by explosively severing the four interstage nuts and bolts, the interstage umbilicals, and the water lines. All other hardlines are disconnected automatically at stage separation. The ascent stage can function as a single unit to accomplish rendezvous and docking with the CSM. The overall dimensions of the LM are given in figure A3-2. Station reference measurements (fig. A1-1) are established as follows:

a. The Z- and Y-axis station reference measurements (inches) start at a point where both axes intersect the X-axis at the vehicle vertical centerline: the Z-axis extends forward and aft of the intersection; the Y-axis, left and right. The point of intersection is established as zero.

b. The +Y-axis measurements increase to the right from zero; the -Y-axis measurements increase to the left. Similarly, the +Z- and -Z-axis measurements increase forward (+Z) and aft (-Z) from zero.

c. The X-axis station reference measurements (inches) start at a design reference point identified as station +X200.000. This reference point is approximately 128 inches above the bottom surface of the footpads (with the landing gear extended); therefore, all X-axis station reference measurements are +X-measurements.

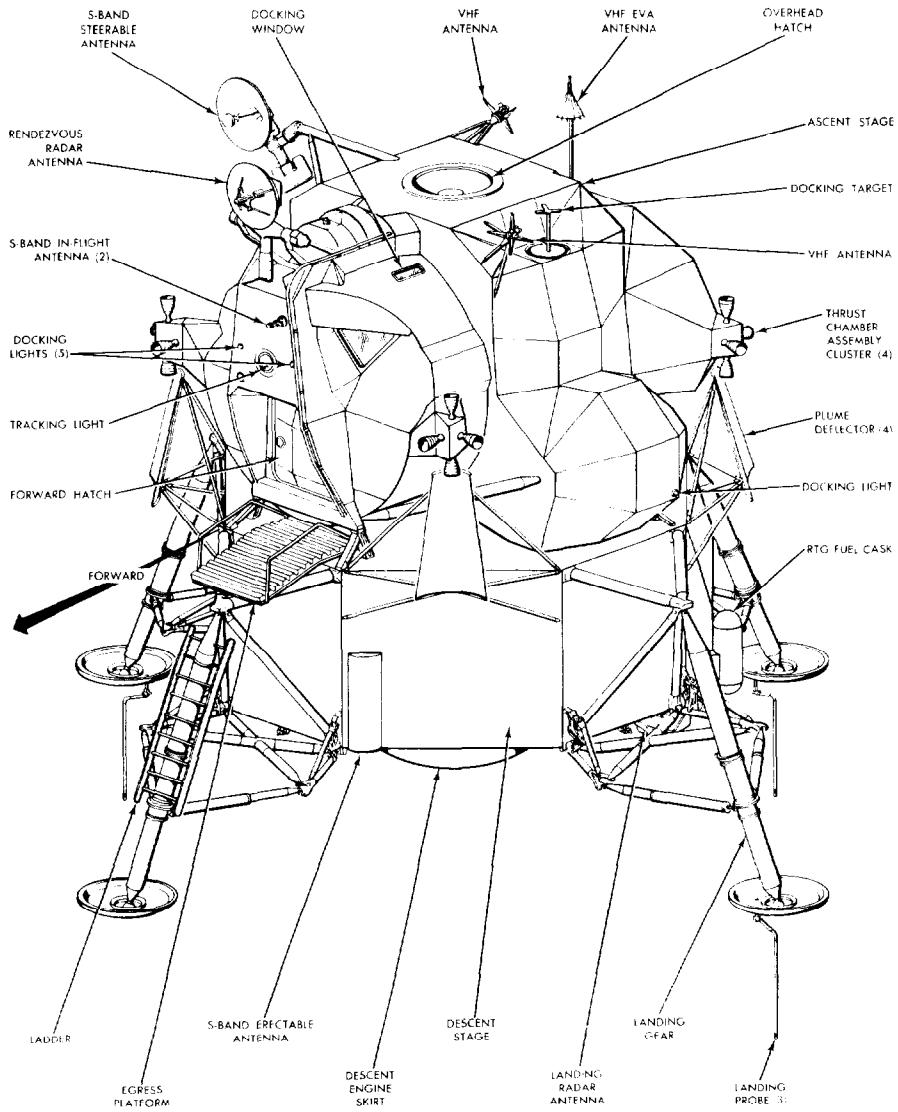

Figure A3-1.- LM configuration.

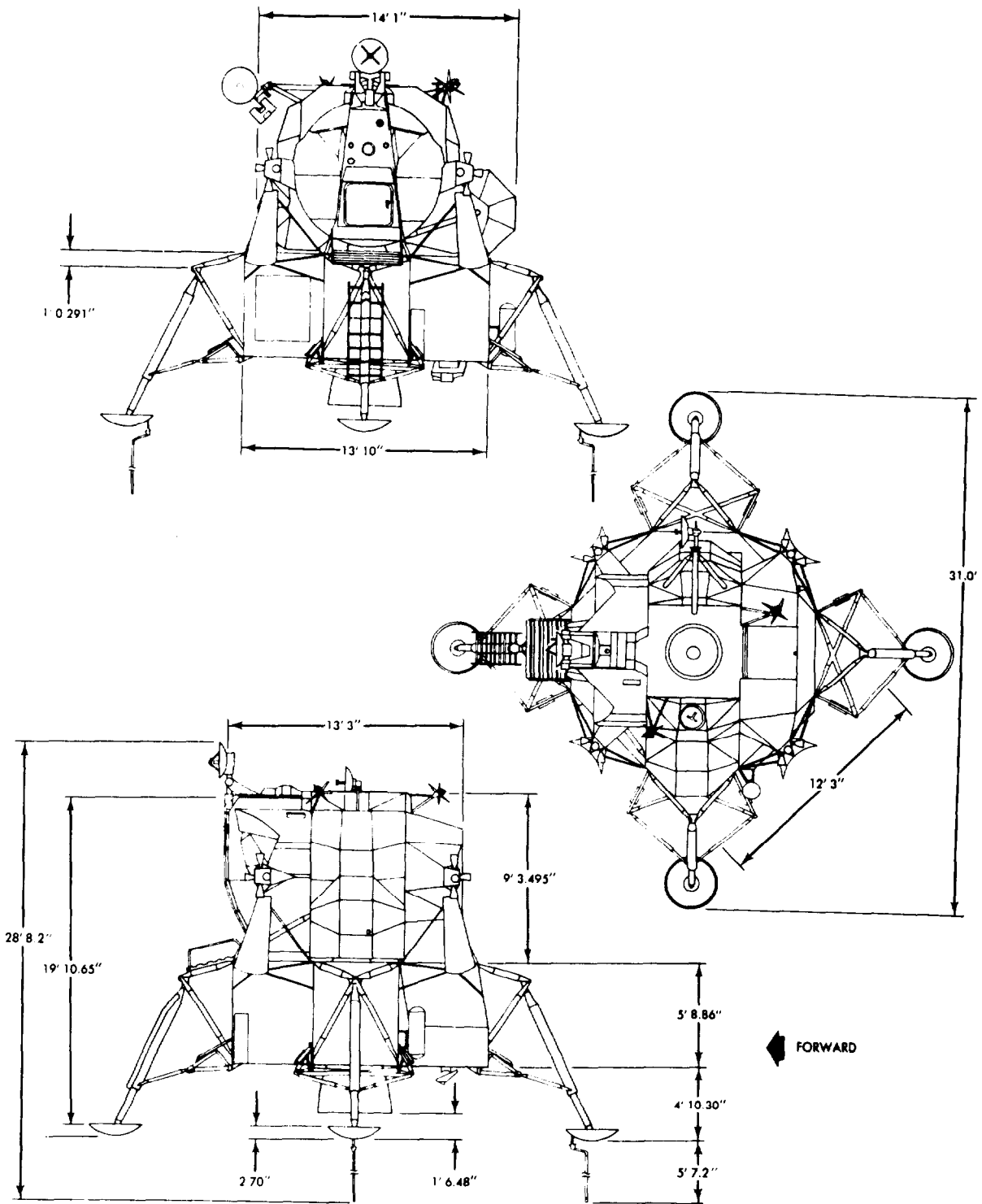

Figure A3-2.- LM overall dimensions.

Ascent Stage

The ascent stage, the control center and manned portion of the LM, accommodates two astronauts. It comprises three main sections: the crew compartment, midsection, and aft equipment bay. The crew compartment and midsection make up the cabin, which has an approximate overall volume of 235 cubic feet. The cabin is climate-controlled, and pressurized to 4.8 ± 0.2 psig. Areas other than the cabin are unpressurized.

Crew Compartment. - The crew compartment is the frontal area of the ascent stage; it is 92 inches in diameter and 42 inches deep. This is the flight station area; it has control and display panels, armrests, body restraints, landing aids, two front windows, a docking window, and an alignment optical telescope (AOT). Flight station centerlines are 44 inches apart; each astronaut has a set of controllers and armrests. Circuit breaker, control, and display panels are along the upper sides of the compartment. Crew provision storage space is beneath these panels. The main control and display panels are canted and centered between the astronauts to permit sharing and easy scanning. An optical alignment station, between the flight stations, is used in conjunction with the AOT. A portable life support system (PLSS) donning station is also in the center aisle, slightly aft of the optical alignment station.

Control and display panels: The crew compartment has 12 control and display panels (fig. A3-3): two main display panels (1 and 2) that are canted forward 10 degrees, two center panels (3 and 4) that slope down and aft 45 degrees towards the horizontal, two bottom side panels (5 and 6), two lower side panels (8 and 12), one center side panel (14), two upper side panels (11 and 16), and the orbital rate display - earth and lunar (ORDEAL) panel aft of panel 8.

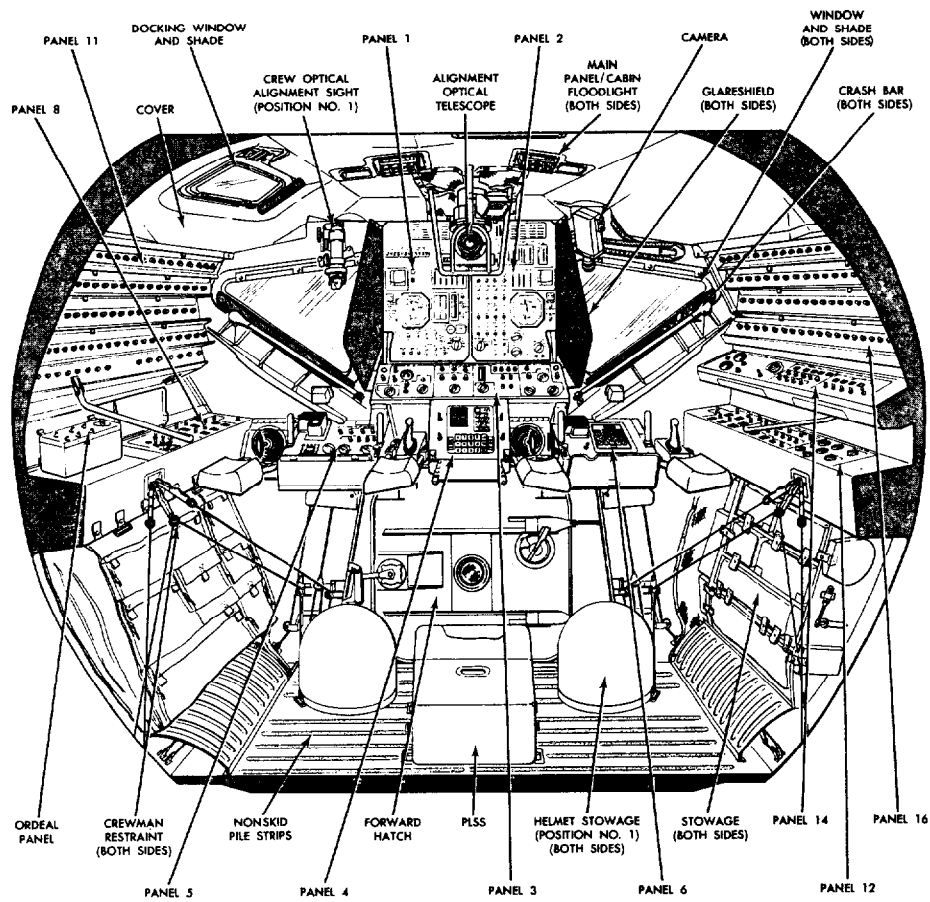

Figure A3-3.- Cabin interior (looking forward).

Panels 1 and 2 are located on each side of the front face assembly centerline, at eye level. Each panel is constructed of two 0.015-inch-thick aluminum-alloy face sheets, spaced 2 inches apart by formed channels. The spacer channels are located along the sheet edges; additional channels, inboard of the edge channels, reinforce the sheets. This forms a rigid box-like construction with a favorable strength-to-weight ratio and a relatively high natural frequency. Four shock mounts support each panel on the structure. Panel instruments are mounted to the back surface of the bottom and/or to the top sheet of the panel. The instruments protrude through the top sheet of the panel. All dial faces are nearly flush with the forward face of the panel. Panel 1 contains warning lights, flight indicators and controls, and propellant quantity indicators. Panel 2 contains caution lights, flight indicators and controls, and Reaction Control Subsystem (RCS) and Environmental Control Subsystem (ECS) indicators and controls.

Panel 3 is immediately below panels 1 and 2 and spans the width of these two panels. Panel 3 contains the radar antenna temperature indicators and engine, radar, spacecraft stability, event timer, RCS and lighting controls.

Panel 4 is centered between the flight stations and below panel 3. Panel 4 contains attitude controller assembly (ACA) and thrust translation controller assembly (TTCA) controls, navigation system indicators, and LM guidance computer (LGC) indicators and controls. Panels 1 through 4 are within easy reach and scan of both astronauts.

Panels 5 and 6 are in front of the flight stations at astronaut waist height. Panel 5 contains lighting and mission timer controls, engine start and stop pushbuttons, and the X-translation pushbutton. Panel 6 contains abort guidance controls.

Panel 8 is at the left of the Commander's station. The panel is canted up 15 degrees from the horizontal; it contains controls and displays for explosive devices, audio controls, and the TV camera connection.

Panel 11, directly above panel 8, has five angled surfaces that contain circuit breakers. Each row of circuit breakers is canted 15 degrees to the line of sight so that the white band on the circuit breakers can be seen when they open.

Panel 12 is at the right of the LM Pilot's station. The panel is canted up 15 degrees from the horizontal; it contains audio, communications, and communications antennas controls and displays.

Panel 14, directly above panel 12, is canted up 36.5 degrees from the horizontal. It contains controls and displays for electrical power distribution and monitoring.

Panel 16, directly above panel 14, has four angled surfaces that contain circuit breakers. Each row of circuit breakers is canted 15 degrees to the line of sight so that the white band on the circuit breakers can be seen when they open.

The orbital rate display - earth and lunar (ORDEAL) panel is immediately aft of the panel 8. It contains the controls for obtaining LM attitude, with respect to a local horizontal, from the LGC.

Windows: Two triangular windows in the front face assembly provide visibility during descent, ascent, and rendezvous and docking phases of the mission. Both windows have approximately 2 square feet of viewing area; they are canted down to the side to permit adequate peripheral and downward visibility. A third (docking) window is in the curved overhead portion of the crew compartment shell, directly above the Commander's flight station. This window provides visibility for docking maneuvers. All three windows consist of two separated panes, vented to space environment. The outer pane is made of Vycor glass with a thermal (multilayer blue-red) coating on the outboard surface and an antireflective coating on the inboard surface. The inner pane is made of structural glass. It is sealed with a Raco seal (the docking window inner pane has a dual seal) and has a defog coating on the outboard surface and an antireflective coating on the inboard surface. Both panes are bolted to the window frame through retainers.

All three windows are electrically heated to prevent fogging. The heaters for the Commander's front window and the docking window receive their power from 115-volt ac bus A and the Commander's 28-volt dc bus, respectively. The heater for the LM Pilot's front window receives power from 115-volt ac bus B. The heater power for the Commander's front window and the docking window is routed through the AC BUS A: CDR WIND HTR and HEATERS: DOCK WINDOW circuit breakers, respectively; for the LM Pilot's front window, through the AC BUS B: SE WIND HTR circuit breaker. These are 2-ampere circuit breakers on panel 11. The temperature of the windows is not monitored with an indicator; proper heater operation directly affects crew visibility and is, therefore, visually determined by the astronauts. When condensation or frost appears on a window, that window heater is turned on. It is turned off when the abnormal condition disappears. When a window shade is closed, that window heater must be off.

Midsection.- The midsection structure (fig. A3-4) is a ring-stiffened semimonocoque shell. The bulkheads consist of aluminum-alloy, chemically milled skin with fusion-welded longerons and machined stiffeners. The midsection shell is mechanically fastened to flanges on the major structural bulkheads at stations +Z27.00 and -Z27.00. The crew compartment shell is mechanically secured to an outboard flange of the +Z27.00 bulkhead. The upper and lower decks, at stations +X294.643 and +X233.500, respectively, are made of aluminum-alloy, integrally stiffened and machined. The lower deck provides structural support for the ascent stage engine. The upper deck provides structural support for the docking tunnel and the overhead hatch.

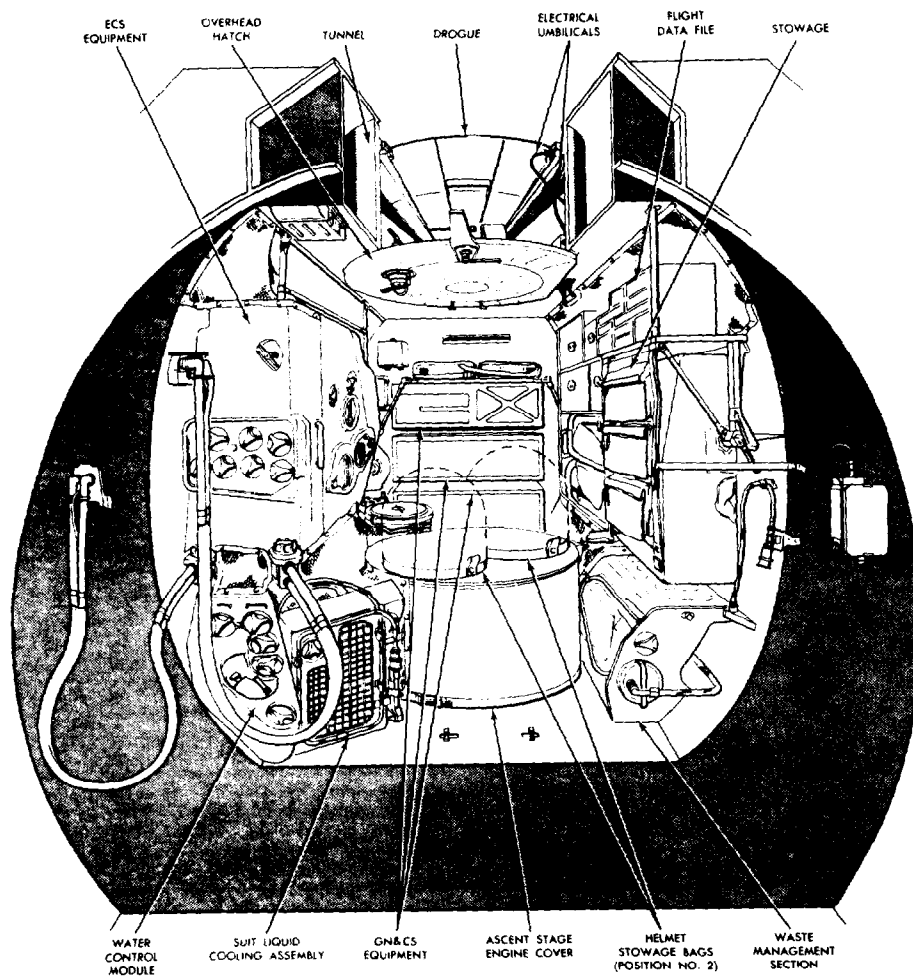

Figure A3-4.- Cabin interior (looking aft).

Two main beams running fore and aft, integral with those above the crew compartment, are secured to the upper deck of the midsection; they support the deck at the outboard end of the docking tunnel. The aft ends of the beams are fastened to the aft bulkhead (-Z27.000), which has provisions for bolting the tubular truss members that support both aft interstage fittings. Ascent stage stress loads applied to the front beam are transmitted through the two beams on the upper deck to the aft bulkhead.

Descent Stage

The descent stage is the unmanned portion of the LM. It contains the descent engine propellant system, auxiliary equipment for the astronauts, and scientific experiment packages to be placed on the lunar surface. The descent stage structure provides attachment and support points for securing the LM within the spacecraft-lunar module adapter (SLA).

LM - SLA - S-IVB Connections

At earth launch, the LM is within the SLA, which is connected to the S-IVB booster. The SLA has an upper section and a lower section. The outriggers, to which the landing gear is attached, provide attachment points for securing the LM to the SLA lower section. The LM is mounted to the SLA support structure on adjustable spherical seats at the apex of each of the four outriggers; it is held in place by a tension holddown strap at each mounting point. Before the LM is removed, the upper section of the SLA is explosively separated into four segments. These segments, which are hinged to the lower section, fold back and are then forced away from the SLA by spring thrusters. The LM is then explosively released from the lower section.

LM-CSM Interfaces

A ring at the top of the ascent stage provides a structural interface for joining the LM to the CSM. The ring, which is compatible with the clamping mechanisms in the CM, provides structural continuity. The drogue portion of the docking mechanism is secured below this ring. The drogue is required during docking operations to mate with the CM-mounted probe. See figure A3-5 for orientation of the LM to the CSM.

Crew transfer tunnel.- The crew transfer tunnel (LM-CM interlock area) is the passageway created between the LM overhead hatch and the CM forward pressure hatch when the LM and the CSM are docked. The

tunnel permits intervehicular transfer of crew and equipment without exposure to space environment.

Final docking latches: Twelve latches are spaced equally about the periphery of the CM docking ring. They are placed around and within the CM tunnel so that they do not interfere with probe operation. When secured, the latches insure structural continuity and pressurization between the LM and the CM, and seal the tunnel interface.

Umbilical: An electrical umbilical, in the LM portion of the tunnel, is connected by an astronaut to the CM. This connection can be made without drogue removal.

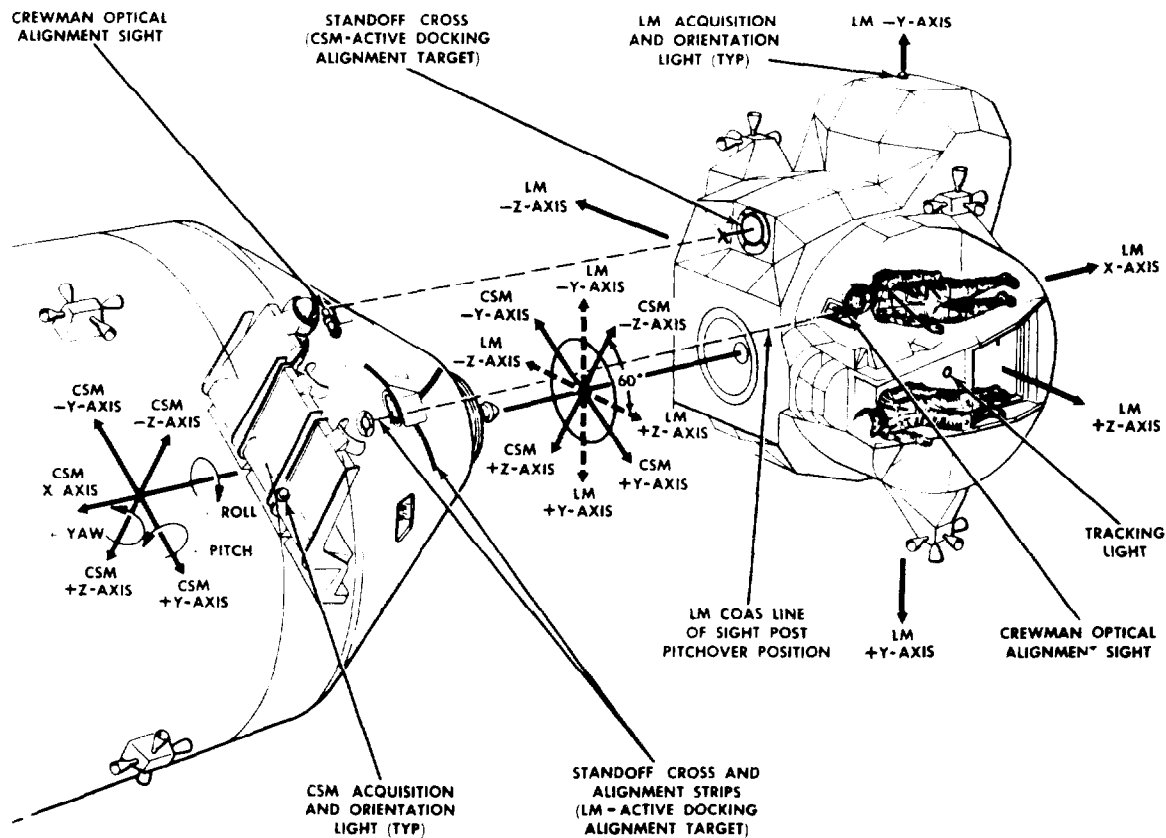

Figure A3-5.- LM-CSM reference axes.

Docking hatches.- The LM has a single docking (overhead) hatch; the CSM has a single, integral, forward hatch. The LM overhead hatch is not removable. It is hinged to open 75 degrees into the cabin.

Docking drogue.- The drogue assembly is a conical structure with provisions for mounting in the LM portion of the crew transfer tunnel. The drogue may be removed from either end of the crew transfer tunnel and may be temporarily stowed in the CM or the LM, during Service Propulsion System (SPS) burns. One of the three tunnel mounts contains a locking mechanism to secure the installed drogue in the tunnel.

Docking probe.- The docking probe provides initial CM-LM coupling and attenuates impact energy imposed by vehicle contact. The docking probe assembly consists of a central body, probe head, capture latches, pitch arms, tension linkages, shock attenuators, a support structure, probe stowage mechanism, probe extension mechanism, probe retraction system, an extension latch, a preload torque shaft, probe electrical umbilicals, and electrical circuitry. The assembly may be folded for removal and stowage from either end of the transfer tunnel.

The probe head is self-centering. When it centers in the drogue the three capture latches automatically engage the drogue socket. The capture latches can be released by a release handle on the CM side of the probe or by depressing a probe head release button from the LM side, using a special tool stowed on the right side stowage area inside the cabin.

Docking aids.- Visual alignment aids are used for final alignment of the LM and CSM, before the probe head of the CM makes contact with the drogue. The LM +Z-axis will align 50 to 70 degrees from the CSM -Z-axis and 30 degrees from the CSM +Y-axis. The CSM position represents a 180-degree pitchover and a counterclockwise roll of 60 degrees from the launch vehicle alignment configuration.

An alignment target is recessed into the LM so as not to protrude into the launch configuration clearance envelope or beyond the LM envelope. The target, at approximately stations -Y46.300 and -Z0.203, has a radioluminescent black standoff cross having green radioluminescent disks on it and a circular target base painted fluorescent white with black orientation indicators. The base is 17.68 inches in diameter. Cross members on the standoff cross will be aligned with the orientation indicators and centered within the target circle when viewed at the intercept parallel to the X-axis and perpendicular to the Y-axis and Z-axis.

Stowage Provisions

The LM has provisions for stowing crew personal equipment. The equipment includes such items as the docking drogue; navigational star charts and an orbital map; umbilicals; a low-micron antibacteria filter for attachment to the cabin relief and dump valve; a crewman's medical kit; an extravehicular visor assembly (EVVA) for each astronaut; a special multipurpose wrench (tool B); spare batteries for the PLSS packs; and other items.

PART A4

MISSION CONTROL CENTER ACTIVITIES

INTRODUCTION

The Mission Control Center (MCC) is located at the Manned Spacecraft Center in Houston, Texas. The MCC contains the communications, computer display and command systems to effectively monitor and control the Apollo spacecraft. These data were extracted from information furnished by Flight Operations Directorate, Manned Spacecraft Center.

Flight operations are controlled from the MCC. The MCC contains two flight control rooms, but only one control room is used per mission. Each control room, called a Mission Operations Control Room (MOCR), is capable of controlling individual Staff Support Rooms (SSR) located adjacent to the MOCR. Both the MOCR's and the SSR's operate on a 24-hour basis. To accomplish this, the various flight control functions and consoles are staffed by three 9-hour shifts. Figures A4-1 and A4-2 show the floor plans and locations of personnel and consoles in the MOCR and the SSR's. Figure A4-3 shows MOCR activity during the Apollo 13 flight, and figure A4-4 shows the MOCR and SSR organizational structure.

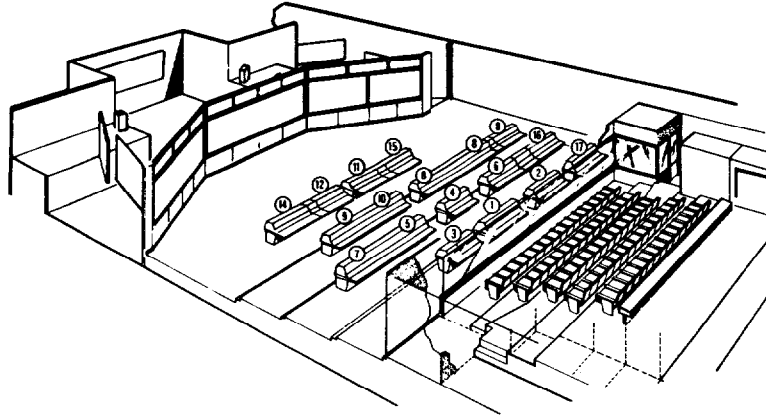

1. Flight Operations Director: Responsible for successful completion of mission flight operations for all missions being supported.

2. Mission Director: Overall mission responsibility and control of flight test operations, which include launch preparation. In Project Mercury there were no alternative mission objectives that could be exercised other than early termination of the mission. The Apollo missions, however, offer many possible alternatives which have to be decided in real time.

3. Public Affairs Officer: Responsible for providing information on the mission status to the public.

4. Flight Director: Responsible for detailed control of the mission from lift-off until conclusion of the flight.

5. Assistant Flight Director: Responsible to the Flight Director for detailed control of the mission from lift-off through conclusion of the flight; assumes the duties of the Flight Director during his absence.

6. Experiments and Flight Planning: Plans and monitors accomplishment of flight planning and scientific experiment activities.

7. Operations and Procedures Officer: Responsible to the Flight Director for the detailed implementation of the MCC/Ground Operational Support Systems mission control procedures.

8. Vehicle Systems Engineers: Monitor and evaluate the performance of all electrical, mechanical and life support equipment aboard the spacecraft (this includes the Agena during rendezvous missions).

9. Flight Surgeon: Directs all operational medical activities concerned with the mission, including the status of the flight crew.

10. Spacecraft Communicator: Voice communications with the astronauts, exchanging information on the progress of the mission with them.

11. Flight Dynamics Officer: Monitors and evaluates the flight parameters required to achieve a successful orbital flight; gives "GO" or "ABORT" recommendations to the Flight Director.

12. Retrofire Officer: Monitors impact prediction displays and is responsible for determination of retrofire times.

14. Booster Systems Engineer: Monitors propellant tank pressurization systems and advises the flight crew and/or Flight Director of systems abnormalities.

15. Guidance Officer: Detects Stage I and Stage II slowrate deviations and other programmed events, verifies proper performance of the Inertial Guidance System, commands onboard computation function and recommends action to the Flight Director.

16. Network Controller: Has detailed operational control of the Ground Operational Support System network.

17. Department of Defense Representative: Overall control of Department of Defense forces supporting the mission, including direction of the deployment of recovery forces, the operation of the recovery communications network, and the search, location and retrieval of the crew and spacecraft.

Figure A4-1.- Personnel and console locations.

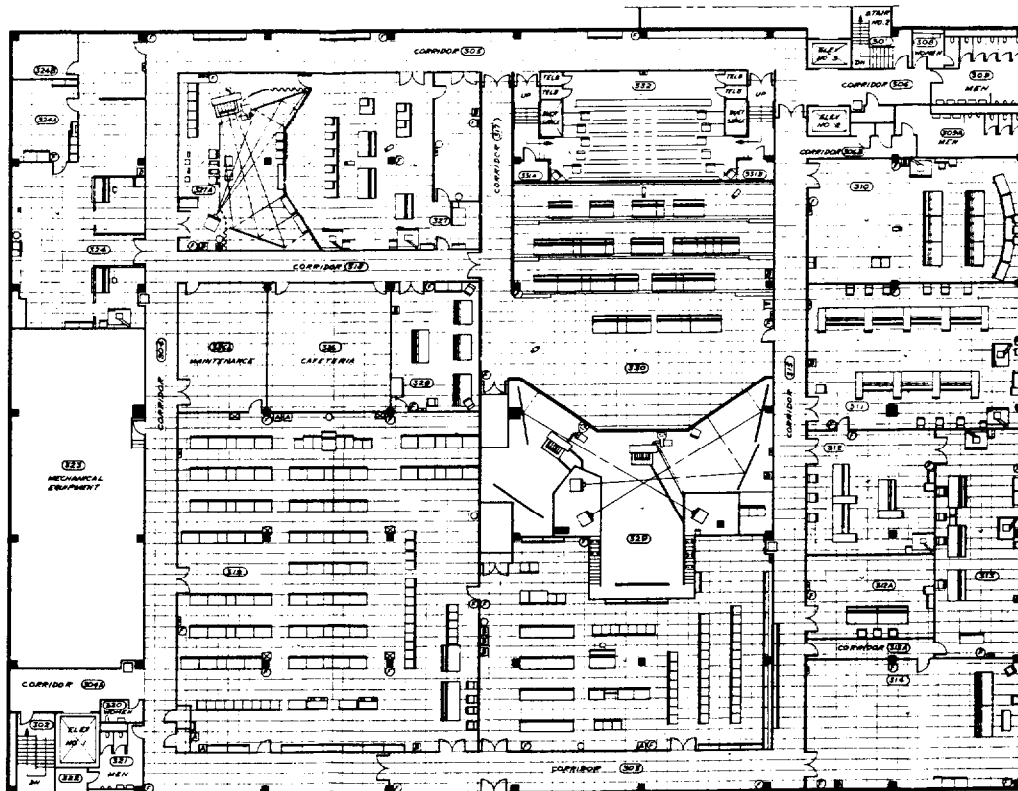

- Legend of symbols
- Clock
 - Zone fire alarm panel
 - Ⓐ "A" power panel
 - Ⓑ "B" power panel
 - Ⓕ Fire extinguisher
 - ⊠ Air duct
 - Ⓞ Ozone exhaust
- | Room no. | Room name |
|----------|---------------------------------------|
| 310 | Flight dynamics SSR |
| 311 | Vehicle systems SSR |
| 312 | Life systems SSR |
| 312A | Flight crew SSR |
| 313 | Operation and procedures SSR |
| 314 | ALSEP SSR |
| 316 | Control and display terminal |
| 319 | Display and timing |
| 324 | } Meteorological center |
| 324A | |
| 324B | |
| 327 | Recovery control |
| 327A | Recovery control display projection |
| 328 | Simulation control |
| 329 | Summary display projection |
| 330 | Mission operations control room no. 1 |
| 331A | } Comm booth |
| 331B | |
| 332 | Visitors viewing area |

Figure A4-2.- Floor plan of MOCR and SSR's.

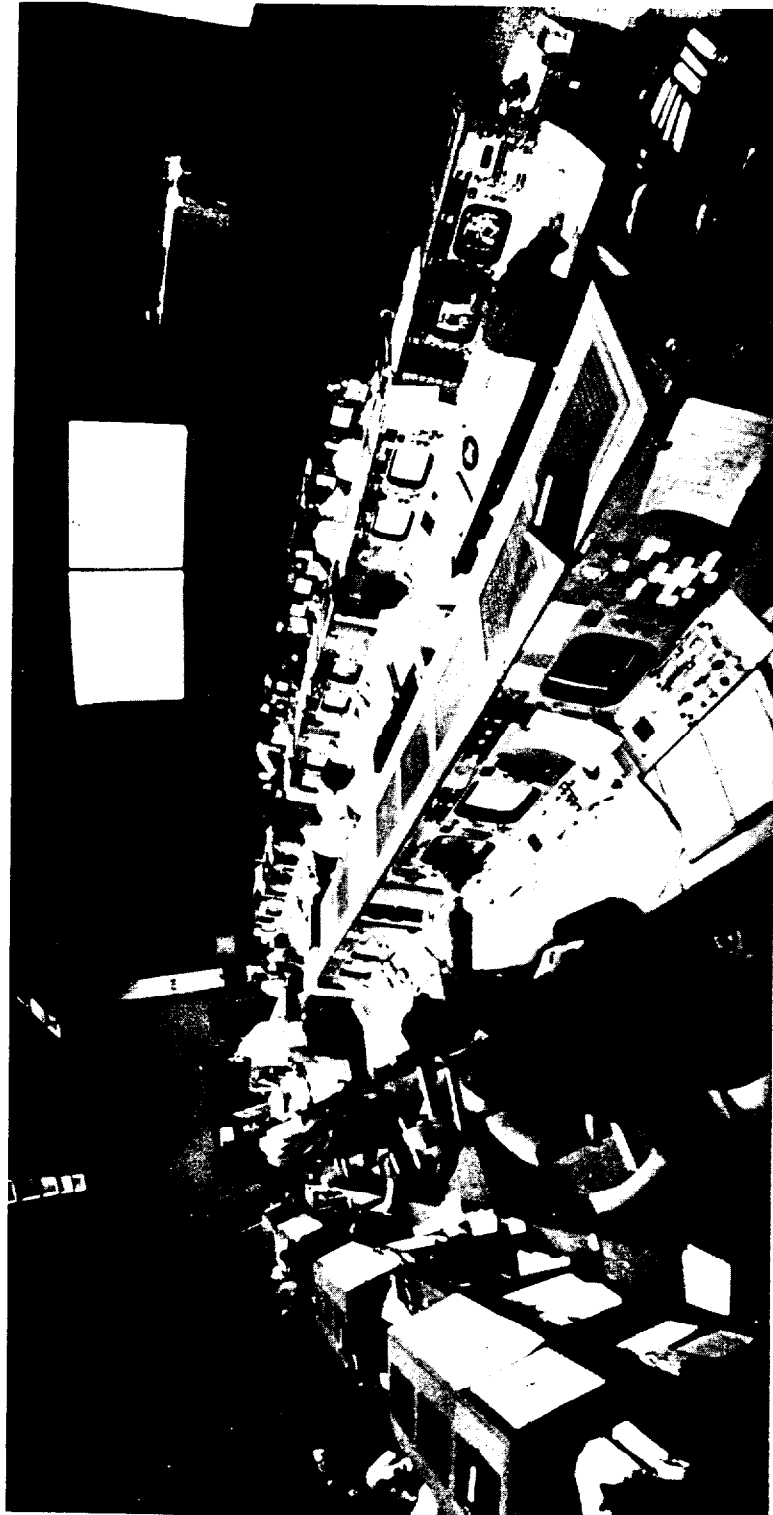

Figure A4-3.- MOCR activity during Apollo 13.

A-127

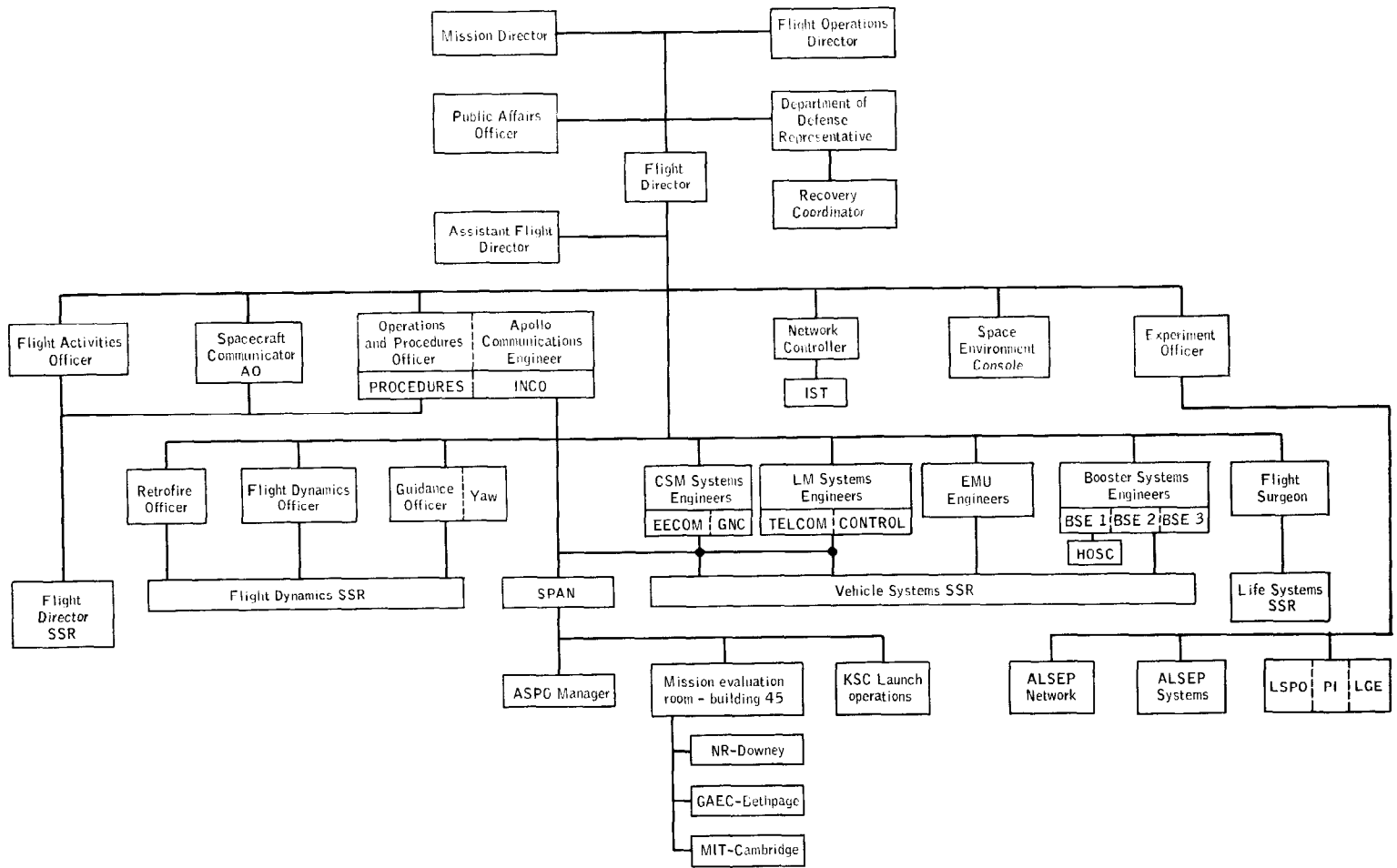

Figure A4-4.- MOCR and SSR organizational structure.

MISSION OPERATIONS CONTROL ROOM

The MOCR was the center for mission control operations. The prime control positions were stationed in this area. The MOCR was broken down into three operations groups. Responsibilities of the groups were as follows:

a. Mission Command and Control Group

- (1) Mission Director (MD)
The MD was responsible for overall conduct of the mission.
- (2) Flight Operations Director (FOD)
The FOD was responsible for the interface between the Flight Director and management.
- (3) Flight Director (FD)
The FD was responsible for MOCR decisions and actions concerning vehicle systems, vehicle dynamics, and MCC/MSFN operations.
- (4) Assistant Flight Director (AFD)
The AFD was responsible for assisting the Flight Director in the performance of his assigned duties.
- (5) Flight Activities Officer (FAO)
The FAO was responsible for developing and coordinating the flight plan.
- (6) Department of Defense Representative (DOD)
The DOD Representative was responsible for coordination and direction of all DOD mission support forces and sites.
- (7) Assistant DOD Representative
The Assistant DOD Representative was responsible for assisting the DOD Representative in the performance of his task.
- (8) Network Controller (NC) (NETWORK)
The Network Controller was responsible to the Flight Director for the detailed operational control and failure analysis of the MSFN.
- (9) Assistant Network Controller
The Assistant Network Controller assisted the Network Controller in the performance of his duties and was responsible for all MCC equipment and its ability to support.

- (10) Public Affairs Officer (PAO)
The PAO was responsible for keeping the public informed on the progress of the mission.
- (11) Surgeon
The Flight Surgeon was responsible to the Flight Director for the analysis and evaluation of all medical activities concerned with the flight.
- (12) Spacecraft Communicator (CAPCOM)
The Spacecraft Communicator was responsible to the Flight Director for all voice communications with the flight crew. The CAPCOM also served in conjunction with FAO as a crew procedures advisor. This position was manned by a member of the backup flight crew.
- (13) Experiments Officer (EO) (EXPO)
The primary function of the EO was to provide overall operational coordination and control for the Apollo Lunar Surface Experiment Package (ALSEP), and the Lunar Geology Experiment (LGE). The coordination was with the various MOCR operational positions and the ALSEP SSR; the Principal Investigators, Management, the Program Officer, Goddard, and the Manned Space Flight Network. The EO was also responsible to the Flight Director for providing ALSEP and LGE status and any ALSEP or LGE activities that could have an effect on the Apollo mission.

b. Systems Operations Group (MOCR)

- (1) Environmental, Electrical, and Communications (EECOM)
The CSM EECOM Engineer was responsible to the FD for monitoring and troubleshooting the CSM environmental, electrical, and sequential systems.
- (2) Guidance, Navigation, and Control (GNC)
The GNC Engineer was responsible to the Flight Director for monitoring and troubleshooting the CSM guidance, navigation, control, and propulsion systems.
- (3) TELCOM
The LM Environmental and Electrical Engineer was responsible to the FD for monitoring and troubleshooting the LM environmental, electrical, and sequential systems.

(4) CONTROL

The LM Guidance, Navigation, and Control Engineer was responsible to the Flight Director for monitoring and troubleshooting the LM guidance, navigation, control, and propulsion systems.

(5) Booster Systems Engineer (BSE)

The Booster Systems Engineers' responsibilities were delegated as follows:

(a) BSE 1 had overall responsibility for the launch vehicle including command capability. In addition, BSE 1 was responsible for all S-IC and S-II stage functions.

(b) BSE 2 had prime responsibility for all S-IVB stage functions with the exception of command.

(c) BSE 3 had prime responsibility for all instrument unit (IU) functions with the exception of command.

(6) Apollo Communications Engineer (ACE) (INCO) and Operations and Procedures Officer (O&P) (PROCEDURES)

The INCO and O&P shared a console and responsibility. The INCO's prime responsibility to the Flight Director was for monitoring and troubleshooting the CSM, LM, TV, PLSS, and erectable antenna communication systems. He was also responsible for execution of all commands associated with the communication systems. The O&P's prime responsibility to the Flight Director was for the detailed implementation of the MCC/MSFN/GSFC/KSC mission control interface procedures. The O&P was also responsible for scheduling and directing all telemetry and DSE voice playbacks. He also developed all communication inputs and changes to the ground support timeline.

c. Flight Dynamics Group

(1) Flight Dynamics Officer (FIDO)

The Flight Dynamics Officer participated in prelaunch checkout designed to insure system readiness, monitored powered flight events and trajectories from the standpoint of mission feasibility; monitored reentry events and trajectories, and updated impact point estimates as required.

(2) Retrofire Officer (RETRO)

The Retrofire Officer participated in prelaunch checkout designed to insure system readiness and maintained an updated reentry plan throughout the mission.

(3) Guidance Officer (GUIDO) and YAW

The Guidance Officer participated in prelaunch checkout designed to insure system readiness and performed the guidance monitor functions during power flight and spacecraft initialization. The GUIDO was also responsible for CSM and LM display keyboards (DSKY) as well as CMC and LGC command updates. The second Guidance Officer (YAW) had the same duties except that he was not responsible for command functions.

MCC SUPPORT ROOMS

Each MOCR group had a staff support room (SSR) to support all activities required by each MOCR position. These SSR's were strategically located in areas surrounding the MOCR's and were manned by the various personnel of a given activity.

a. Staff Support Room

(1) Flight Dynamics SSR

The Flight Dynamics SSR was responsible to the Flight Dynamics Group in the MOCR for providing detailed analysis of launch and reentry parameters, maneuver requirements, and orbital trajectories. It also, with the assistance of the Mission Planning and Analysis Division (MPAD), provided real-time support in the areas of trajectory and guidance to the MOCR Flight Dynamics team on trajectory and guidance matters. An additional service required provided interface between the MOCR Flight Dynamics team and parties normally outside the Flight Control team such as Program Office representatives, spacecraft contractor representatives, et cetera.

(2) Flight Director's SSR

The Flight Director's SSR was responsible for staff support to the Flight Director, AFD, Data Management Officer, and FAO. This SSR was also responsible to the Apollo Communications Engineer in the MOCR for monitoring the detailed status of the communication systems. The SSR was also responsible for two TV channel displays: Ground Timeline and Flight Plan.

- (3) Vehicle Systems SSR
The Vehicle Systems SSR was responsible to the Systems Operations Group in the MOCR for monitoring the detailed status and trends of the flight systems; avoiding, correcting, and circumventing vehicle equipment failures; and detecting and isolating vehicle malfunctions. After the S-IVB was deactivated, the portable life support system engineer and the Experiments Officer occupied the two booster consoles in the Vehicle Systems SSR.
- (4) Life Systems SSR
The Life Systems SSR was responsible to the Life Systems Officer for providing detailed monitoring of the physiological and environmental data from the spacecraft concerning the flight crew and their environment.
- (5) Spaceflight Meteorological Room
The Spaceflight Meteorological Room was responsible to the Mission Command and Control Group for meteorological and space radiation information.
- (6) Space Environment Console (SEC) (RADIATION)
The Space Environment Console was manned jointly by a Space Environment Officer (SEO) from the Flight Control Division and a Space Environment Specialist from the Space Physics Division. During mission support, the SEO was responsible for the console position, the proper operation of the console, and the completion of all necessary activities and procedures. The SEC was the central collecting and coordinating point at MSC for space radiation environment data during mission periods.
- (7) Spacecraft Planning and Analysis (SPAN) Room
The SPAN Room was the liaison interface between the MOCR, the data analysis team, vehicle manufacturers, and KSC Launch Operations. During countdown and real-time operations, the SPAN team leader initiated the appropriate action necessary for the analysis of spacecraft anomalies.
- (8) Recovery Operations Control Room (ROCR)
The Recovery Operations Control Room was responsible for the recovery phase of the mission and for keeping the Flight Director informed of the current status of the recovery operations. Additionally, the Recovery Operations Control Room provided an interface between the DOD Representative and the recovery forces.

(9) ALSEP SSR

The ALSEP SSR was responsible to the Experiments Officer, Lunar Surface Program Office, and Principal Investigators for providing detailed monitoring of ALSEP central station and experiments data. The SSR was also responsible for all scheduling of activities, commanding, and data distribution to appropriate users.

MISSION SUPPORT AREAS

The two primary support areas for the MOCR flight control team were the CCATS area and the RTCC area located on the first floor of the MCC. These two areas of support and their operational positions interfaced with the MOCR flight control team.

Communications, Command, and Telemetry System (CCATS)

The CCATS was the interface between the MCC and MSFN sites. CCATS was a hardware/software configuration (Univac 494 computer) having the capability to provide for the reception, transmission, routing, processing, display and control of incoming, outgoing, and internally generated data in the areas of telemetry, command, tracking, and administrative information. The CCATS consoles were augmented with various high-speed printers (HSP) and TTY receive-only (RO) printers adjacent to the consoles. Figure A4-5 illustrates the CCATS operational organization. CCATS personnel interfaced with the MOCR flight control team were as follows:

a. Command Support Console

This console was a three-position support element whose operators were concerned with the total command data flow from the generation and transfer of command loads from the RTCC to the verification of space vehicle acceptance following uplink command execution. The three command positions were:

- (1) Real-Time Command Controller (RTC)
- (2) Command Load Controller (LOAD CONTROL)
- (3) CCATS Command Controller (CCATS CMD)

b. Telemetry Instrumentation Control Console

This console was a two-position support element whose operators were concerned with the telemetry control of incoming data from the MSFN. Certain telemetry program control was exercised on the incoming data. The two telemetry positions were:

- (1) Telemetry Instrumentation Controller (TIC)
- (2) CCATS Telemetry Controller (CCATS TM)

c. Instrumentation Tracking Controller Console

This console was a two-position support element whose operators were concerned with the tracking radar support involving the spacecraft and ground systems operations and configurations. The two tracking positions were:

- (1) Instrumentation Tracking Controller (TRK)
- (2) USB Controller

d. Central Processor Control Console

This console was a two-position support element and provided the facilities for monitoring and controlling selected software and hardware functions applicable to the configuration of the CCATS computer complex. The two positions were:

- (1) Central Processor Controller (CPC)
- (2) Central Processor Maintenance and Operations (M&O)

e. Communications Controller Console

The operators of this console provided overall communications management between MCC and MSFN elements.

Real-Time Computer Complex (RTCC)

The RTCC provided the data processing support for the MCC. It accomplished the telemetry processing, storage and limit sensing, trajectory and ephemeris calculations, command load generation, display generation, and many other necessary logic processing and calculations. The RTCC supported both MOCR's and as such had two divisions known as computer controller complexes, each capable of supporting one MOCR. Each complex was supported by two IBM 360 computers, known as the mission operations computer (MOC) and the dynamic standby computer (DSC). The DSC served as backup to the MOC. Figure A4-6 illustrates the RTCC operational organization for each complex. A brief description of the RTCC positions follows.

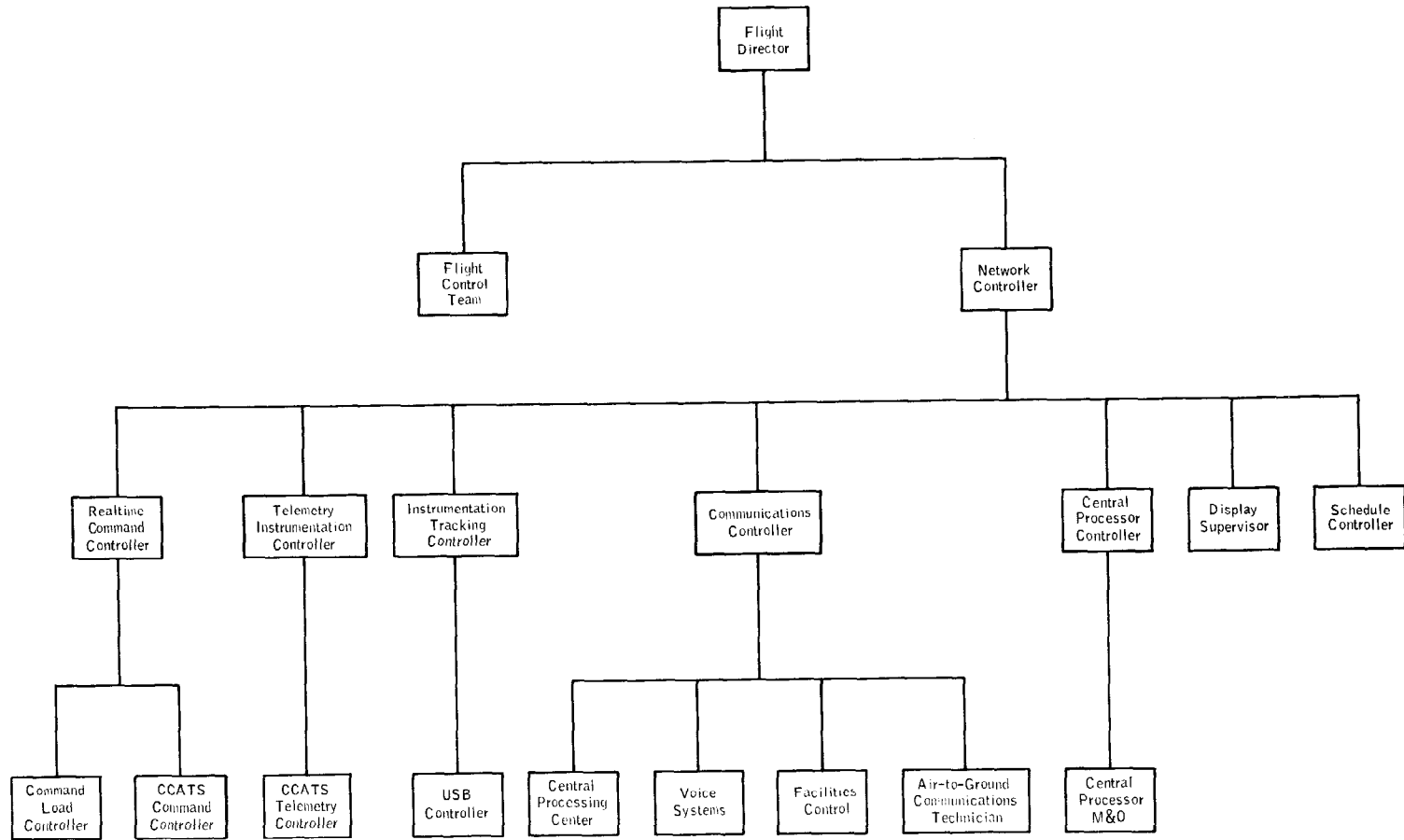

Figure A4-5.- CCATS operational organization.

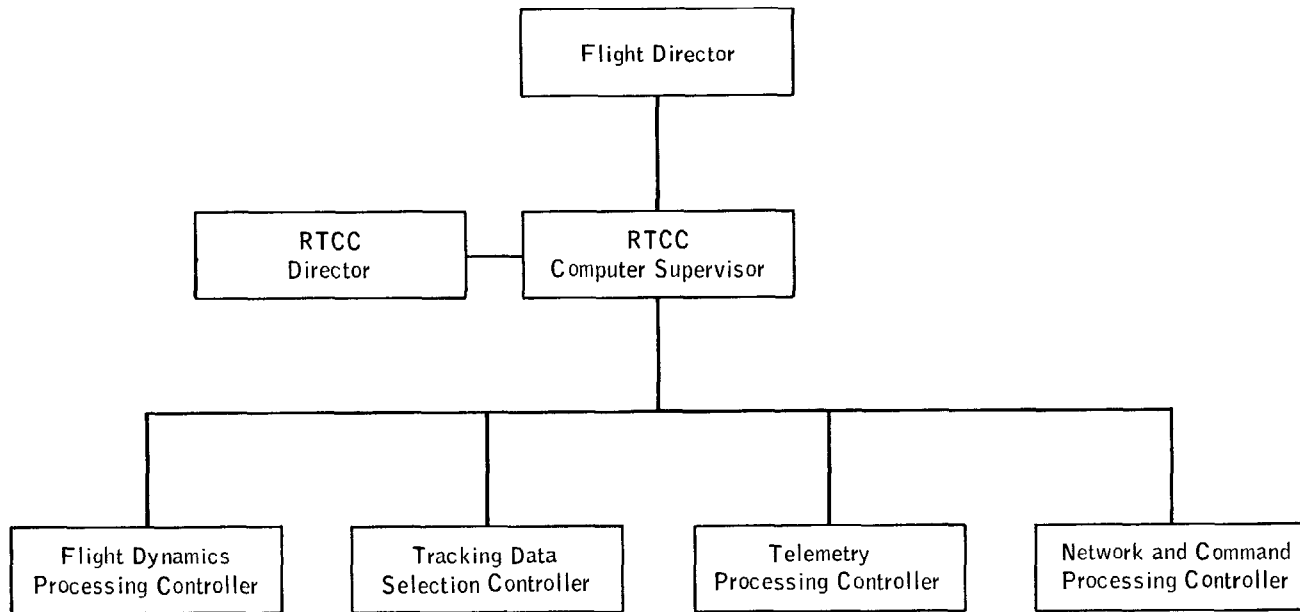

Figure A4-6.- RTCC operational organization.

- a. RTCC Director
Controlled and coordinated the activities of the two computer complexes.
- b. RTCC Computer Supervisor (Computer Sup)
Responsible for the operational control of the complex.
- c. Tracking Data Selection Controller (Data Select)
Monitored the tracking data being processed in the RTCC and insured the data used as input to the MOCR and SSR displays was the best obtainable. Evaluated the quality of tracking data received during the launch phase and selected the source of data. Evaluated the trajectory determinations and was responsible for the various related displays. Informed the MOCR Flight Dynamics Officer concerning the quality and status of the data.
- d. Flight Dynamics Processing Controller (Computer Dynamics)
Controlled and monitored all trajectory computing requirements requested by MOCR flight dynamics personnel and MOCR recovery activities. Performed evaluation and analysis of the predicted trajectory quantities as they related to the mission plan.
- e. Network and Command Processing Controller (Computer Command)
Coordinated with MOCR personnel who had command responsibility and directed the generation, review, and transfer of requested command loads.
- f. Telemetry Processing Controller (Computer TM)
This position had access to all telemetry data entering and leaving the RTCC and interfaced with the MOCR and SSR positions using telemetry data. Duties included monitoring telemetry input data, coordinating input requests, monitoring computer generated telemetry displays, and keeping the MOCR aware of the telemetry processing status.

NOTE

From ALSEP deployment to splashdown TRK and TIC will be responsible for scheduling sites to support the scientific package. This will include calling up of sites and data/command handling to MCC.

This page left blank intentionally.

PART A5

EXCERPTS FROM APOLLO FUEL CELL AND

CRYOGENIC GAS STORAGE SYSTEM FLIGHT SUPPORT HANDBOOK

The information contained in this part was extracted from the Apollo Fuel Cell and Cryogenic Gas Storage System Flight Support Handbook, dated February 18, 1970. It was prepared by the Propulsion and Power Division of the Manned Spacecraft Center. The text was taken from Section 2.0 Fuel Cell Operation and Performance, Section 3.0 Cryogenic Gas Storage System Operation and Performance, Section 4.0 Instrumentation and Caution and Warning, Section 5.0 Fuel Cell/Cryogenic Subsystem Malfunction Procedures, Section 7.0 Fuel Cell/Cryogenic Subsystem Hardware Description.

2.0 FUEL CELL OPERATION AND PERFORMANCE

The fuel cell operation and performance are described by nominal system performance and operational data for both ground and flight environments and fuel cell response to a variety of component malfunctions.

Nominal system performance and operational data are presented in curve and table format to assist in rapid reference. The data include procedures and curves for making rough estimates of radiator performance. Apollo 10 and 11 flight data were used to generate a portion of the curves used for evaluating radiator performance.

Fuel cell response of measured parameters (temperature, voltage, etc.) to specific component malfunctions make up the remainder of the data presented. The curves are adequately noted to allow application without written procedures.

The fuel cell operation and performance data assist the user in evaluating fuel cell performance, identification of flight anomalies and provide a basis for developing corrective actions.

The sources of the data were the original "NASA Apollo Block II Fuel Cell, Cryogenic Gas Storage System, and Flight Batteries Flight Support Handbook," dated September 1968, NASA-MSD, North American Rockwell, Pratt and Whitney, Beech Aircraft and Boeing-Houston. These data were reviewed and found to be accurate as of December 1969.



2.1 FUEL CELL SYSTEM OPERATIONAL PARAMETERS SUMMARY (Continued)

NOMINAL FUEL CELL PRESSURIZED SYSTEM VOLUMES

Hydrogen Loop	250 in ³
Oxygen Loop	88 in ³
Nitrogen Loop	3098 in ³
Glycol Loop (Fuel Cell)	107 in ³
Glycol Accumulator (Fuel Cell)	30 in ³
Net Fuel Cell Glycol Volume	117 in ³ (20 in ³ water glycol removed from accumulator)
Average NR Glycol Plumbing and Radiator Volume	66 in ³
Estimated Fuel Cell Glycol Loop Volume	183 in ³ = 0.79 gallons

TOTAL SYSTEM SPEC LEAKAGE INTO BAY IV

Hydrogen System, Oxygen System, and Fuel Cells (3)	5.3 x 10 ⁻³ scc/sec of Helium
Fuel Cell (3) nitrogen system	1.6 x 10 ⁻⁴ scc/sec of Helium

SYSTEM PRESSURE SUMMARY

SUPPLY PRESSURES

	SUPPLY PRESSURES (PSIA)		REGULATED PRESSURES S/N 650769 AND ON		
	NOMINAL	MINIMUM	ABSOLUTE PSIA	ABOVE NITROGEN PRESSURE PSI	DEAD BAND PSI
Hydrogen	245 ± 15	100	57.90 - 67.60	6.20 - 11.35	.2-.4
Oxygen	900 ± 35	150	57.90 - 67.95	6.20 - 11.7	.5-.7
Nitrogen	1500	165	50.20 - 57.75	---	2.0-2.15

DELIVERY PRESSURE

Water 62 psia

PRESSURE LIMITS

Maximum water system discharge back pressure 59.55 psia
 Maximum reactant vent back pressure 16 psia

2.1 FUEL CELL SYSTEM OPERATIONAL PARAMETERS SUMMARY (Continued)

ENVIRONMENTAL CONTROL SYSTEM WATER SYSTEM PRESSURES

Potable Water Tank 25 psia \pm 2, Plus cabin pressure
 Water Relief Valve 5.5 psid \pm 1
 Water Tank Vent Valve 44 psia \pm 4
 Cabin Relief Valve 6.0 $\begin{matrix} +.2 \\ -.4 \end{matrix}$

FUEL CELL GROUND HEATER POWER SETTINGS

STARTUP HEAT SCHEDULE

ZONE	AMPERES
1	2.8 - 3.2
2	38.0 - 42.0
3	2.8 - 3.2

NORMAL OPERATION HEAT SCHEDULE

ZONE	SEA LEVEL OPERATION	VACUUM OPERATION
1	1.2 - 1.6 amperes	0 amperes
2	8.0 - 12.0 amperes	0 amperes
3	1.2 - 1.6 amperes	0 amperes

DRYOUT HEAT SCHEDULE

ZONE	SEA LEVEL OPERATION	VACUUM OPERATION
1	1.75 - 2.05 amperes	1.5 - 1.65 amperes
2	As required to maintain 460 ^o F to 485 ^o F skin temperature. Approximately 23.9 amps.	21.0 - 22.5 amperes
3	1.75 - 2.05 amperes	1.5 - 1.65 amperes

2.1 FUEL CELL SYSTEM OPERATIONAL PARAMETERS SUMMARY (Continued)

FUEL CELL DISCONNECT OVERLOAD DATA

OVERLOAD CURRENT DATA

Load (amps/ cell)	Required Disconnect Delay (sec)	Test Delay (sec)	Transfer Time (sec)
75	100 minimum	No transfer	
112	25 - 300	80	0.046
150	8 - 150	38	0.046
300	2 - 8	5.81	0.046
450	1 - 2	1.07	0.046
600	0.62 - 1.2	0.776	0.046
750	0.42 - 0.76	0.572	0.046
1000	0.24 - 0.55	0.470	0.046

FUEL CELL DISCONNECT REVERSE CURRENT DATA

REVERSE CURRENT DATA

Load (amps/ cell)	Required Disconnect Delay (sec)	Test Delay (sec)	Transfer Time (sec)
4	No trip	No transfer	
20	1 - 10	2.10	0.046
30	1 - 1.3	1.22	0.046
50	1 - 1.3	1.11	0.046

2.1 FUEL CELL SYSTEM OPERATIONAL PARAMETERS SUMMARY (Continued)

REACTANT CONSUMPTION AND WATER PRODUCTION

LOAD AMPS	<u>O₂ lb/hr</u>	<u>H₂ lb/hr</u>	<u>H₂O</u>	
			<u>lb/hrs</u>	<u>cc/hr</u>
0.5	0.0102	.001285	.01149	5.21
1	0.0204	.002570	.02297	10.42
2	0.0408	.005140	.04594	20.84
3	0.0612	.007710	.06891	31.26
4	0.0816	.010280	.09188	41.68
5	0.1020	.012850	.11485	52.10
6	0.1224	.015420	.13782	62.52
7	0.1428	.017990	.16079	72.94
8	0.1632	.020560	.18376	83.36
9	0.1836	.023130	.20673	93.78
10	0.2040	.025700	.2297	104.20
15	0.3060	.038550	.34455	156.30
20	0.4080	.051400	.45940	208.40
25	0.5100	.064250	.57425	260.50
30	0.6120	.077100	.68910	312.60
35	0.7140	.089950	.80395	364.70
40	0.8160	.10280	.91880	416.80
45	0.9180	.11565	1.03365	468.90
50	1.0200	.12850	1.1485	521.00
55	1.1220	.14135	1.26335	573.10
60	1.2240	.15420	1.3782	625.20
65	1.3260	.16705	1.49305	677.30
70	1.4280	.17990	1.6079	729.40
75	1.5300	.19275	1.72275	781.50
80	1.6320	.20560	1.83760	833.60
85	1.7340	.21845	1.95245	885.70
90	1.8360	.23130	2.06730	937.90
95	1.9380	.24415	2.18215	989.90
100	2.0400	.25700	2.2970	1042.00

FORMULAS:

$$O_2 = 2.04 \times 10^{-2} I$$

$$H_2 = 2.57 \times 10^{-3} I$$

$$H_2O = 10.42 \text{ cc/Amp Hr}$$

$$H_2O = 2.297 \times 10^{-2} \text{ lb/Amp Hr}$$

3.0 CRYOGENIC GAS STORAGE SYSTEM OPERATION AND PERFORMANCE

The cryogenic system operation and performance are described by nominal system performance and operational data for both ground and flight environments.

Nominal system performance and operational data are presented in curve and table format to assist in rapid reference. The curves, with the exception of those used for heat leaks and pressure change rates, are adequately noted to allow application without written procedures. The data include formulas, methods, and curves for calculating cryogenic tank heat leaks and pressure change rates for both equilibrium and non-equilibrium (stratified) conditions. Apollo 7 and 8 flight data were used to provide a comparison of equilibrium (calculated) tank pressure cycle time to actual flight pressure cycle time for a variety of tank quantities.

The fuel cell operation and performance data assist the user in evaluating cryogenic system performance, identification of flight anomalies, and provide a basis for developing corrective actions.

The sources of the data were the original "NASA Apollo Block II Fuel Cell, Cryogenic Gas Storage System, and Flight Batteries Flight Support Handbook," dated September 1968, NASA-MSC, North American Rockwell, Pratt and Whitney, Beech Aircraft and Boeing-Houston. These data were reviewed and found to be accurate as of December 1969.

3.1 CRYOGENIC SYSTEM OPERATIONAL PARAMETERS SUMMARY

	<u>Hydrogen</u>	<u>Oxygen</u>
TANK WEIGHT (PER TANK)		
Empty (Approx.)	80.00 lb.	90.82 lb.
Usable Fluid	28.15 lb.	323.45 lb.
Stored Fluid (100% indication)	29.31 lb.	330.1 lb.
Residual	4%	2%
Maximum Fill Quantity	30.03 lb.	337.9 lb.
TANK VOLUME (PER TANK)	6.80 FT ³	4.75 FT ³
TANK FLOW RATE (PER TANK)		
Max. for 10 Minutes	1.02 lbs/hr	4.03 lbs/hr
Max. for 1/2 hour	————	10.40 lbs/hr
Relief Valve Max Flow	6 lbs/hr @ 130°F	26 lbs/hr @ 130°F
TANK PRESSURIZATION		
Heaters (2 elements per tank)		
Flight		
Resistance	78.4 ohms per element	10.12 ohms per element
Maximum Voltage	28 V DC	28 V DC
Power	10 watts per element*	77.5 watts per element*
Total Heater Heat Input Per Tank (2 Elements)	68.2 BTU/Hr	528.6 BTU/Hr
Ground		
Resistance	78.4 ohms per element	10.12 ohms per element
Maximum Voltage	65.0 V DC	65.0 V DC
Power	54.0 watts per element*	417.5 watts per element*
Total Heater Heat Input Per Tank (2 Elements)	368 BTU/Hr	2848 BTU/Hr

* Conversion Factor: 1 watt = 3.41 BTU/Hr

3.1 CRYOGENIC SYSTEM OPERATIONAL PARAMETERS SUMMARY

		<u>Hydrogen</u>	<u>Oxygen</u>
Pressure Switch			
Open Pressure	Max.	260 psia	935 psia
Close Pressure	Min.	225 psia	865 psia
Deadband	Min.	10 psia	30 psia
Destratification Motors (2 Motors Per Tank)			
Voltage		115/200 V 400 cps	115/200 V 400 cps
Power - Average		3.5 watts per motor*	26.4 watts per motor*
Total Average Motor Heat Input Per Tank		23.8 BTU/Hr	180 BTU/Hr

SYSTEM PRESSURES

Normal Operating		245 ±15 psia	900 ±35 psia
Spec Min. Dead Band of Pressure Switches		10 psi	30 psi

Relief Valve Note: Relief Valves are Referenced to Environmental Pressure, therefore Pressure at Sea Level (psig) will be same value in vacuum (psia)

Crack	Min.	273 psig	983 psig
Full Flow	Max.	285 psig	1010 psig
Reseat	Min.	268 psig	965 psig

Outer Tank Shell Burst Disc

Nominal Burst Pressure		90 ^{+ 10} - 20 psid	75 ± 7.5 psid
------------------------	--	---------------------------------	---------------

SYSTEM TEMPERATURES

Stored Fluid		-425 to 80 ^o F	-300 ^o F to 80 ^o F
Heater Thermostat (Over Temp. Protection)		N.A. for 113 and Subs.	N.A. for 114 and Subs.
Open	Max.	80 ^o F ± 10	80 ^o F ± 10
Close	Min.	-200 ^o F	-75 ^o F

* Conversion Factor: 1 watt = 3.41 BTU/Hr

3.1 CRYOGENIC SYSTEM OPERATIONAL PARAMETERS SUMMARY

	<u>Hydrogen</u>	<u>Oxygen</u>
TANK HEAT LEAK (SPEC PER TANK)		
Operating (dQ/dM @ 140°F)	7.25 BTU/HR (.0725 #/hr)	27.7 BTU/HR (.79 #/hr)
VALVE MODULE LEAKAGE RATES		
External	400 scc H ₂ /HR/ Valve	400 scc O ₂ /HR/ Valve
	0.736 x 10 ⁻⁶ lbs H ₂ /HR/Valve	9.2 x 10 ⁻⁶ lbs O ₂ /HR/Valve
LIFE	600 HRS @ Cryogenic Temps. and operating pressure -225 psia	600 HRS @ Cryogenic Temps. and operating pressure -865 psia

4.0 INSTRUMENTATION AND CAUTION AND WARNING

The tabular data presented in Tables 4.1 and 4.2 list instrumentation measurements and specify instrumentation range, accuracy and bit value, if applicable. All of the data in Tables 4.1 and 4.2 can be used for system monitoring during ground checkout. Table 4.1 lists data displayed to the crew and telemetered from the vehicle to the Manned Space Flight Network (MSFN) during missions. Table 4.2 lists data available only for system monitoring during ground checkout. Event indications displayed to crew during flight are noted in Table 4.2.

The instrumentation sensor location, with the exception of voltage and current data, can be found by referring to the fuel cell/cryogenic schematics located in Section 7.0. Voltage and current readout and schematic locations can be obtained by referring to North American Rockwell drawings V37-700001, Systems Instrumentation, and V34-900101, Integrated System Schematics Apollo CSM, respectively.

The Caution and Warning System monitors the most critical fuel cell/cryogenic measurements and alerts the flight crew to abnormal system operation. The data presented in Table 4.1 are specification nominal caution and warning limits for the applicable measurements. Malfunctions procedures, Section 5.0, are provided for problem isolation as a result of a caution and warning alarm.

The source of the data was North American Rockwell Measurement Systems End-to-End Calibrated Accuracy Tolerances, TDR68-079, dated January 10, 1969 and the original Flight Support Handbook.

TABLE 4.1
INSTRUMENTATION/CAUTION AND WARNING SUMMARY

A-151

MEASUREMENT NUMBER *	MEASUREMENT NAME	RANGE	ACCURACY		BIT VALUE	CAUTION AND WARNING SETTINGS	
			PERCENT	ACTUAL		LOW	HIGH
CC0206V	DC Bus Voltage A	0-45 volts	±0.94	±0.42V	0.178	26.25V	—
CC0207V	DC Bus Voltage B						
SC2113C	FC 1 Current	0-100 amps	±1.07	±1.07 a	0.395	—	—
SC2114C	FC 2 Current						
SC2115C	FC 3 Current						
SC2060P	FC 1 N ₂ Press	0-75 psia	±4.30	±3.22 psia	0.295	—	—
SC2061P	FC 2 N ₂ Press						
SC2062P	FC 3 N ₂ Press						
SC2066P	FC 1 O ₂ Press	0-75 psia	±4.30	±3.22 psia	0.295	—	—
SC2067P	FC 2 O ₂ Press						
SC2068P	FC 3 O ₂ Press						
SC2069P	FC 1 H ₂ Press	0-75 psia	±4.30	±3.22 psia	0.295	—	—
SC2070P	FC 2 H ₂ Press						
SC2071P	FC 3 H ₂ Press						

* See note, page 4-11

TABLE 4.1
INSTRUMENTATION/CAUTION AND WARNING SUMMARY (Continued)

MEASUREMENT NUMBER *	MEASUREMENT NAME	RANGE	ACCURACY		BIT VALUE	CAUTION AND WARNING SETTINGS	
			PERCENT	ACTUAL		LOW	HIGH
SC2081T	FC 1 Cond Ex Temp	145-250 ⁰ F	±2.18	+2.29 ⁰ F	0.417	150 ⁰ F	175 ⁰ F
SC2082T	FC 2 Cond Ex Temp						
SC2083T	FC 3 Cond Ex Temp						
SC2084T	FC 1 Skin Temp	80-550 ⁰ F	±1.15	±5.40 ⁰ F	1.94	360 ⁰ F	500 ⁰ F
SC2085T	FC 2 Skin Temp						
SC2086T	FC 3 Skin Temp						
SC2087T	FC 1 Rad Out Temp	-50 to +300 ⁰ F	±1.71	5.98 ⁰ F	1.38	-30 ⁰ F	—
SC2088T	FC 2 Rad Out Temp						
SC2089T	FC 3 Rad Out Temp						
SC2090T	FC 1 Rad In Temp	-50 to +300 ⁰ F	±1.71	±5.98 ⁰ F	1.38	—	—
SC2091T	FC 2 Rad In Temp						
SC2092T	FC 3 Rad In Temp						
SC2139R	FC 1 H ₂ Flow Rate	0-0.2 lb/hr	±10.0	±0.020 lb/hr	0.00079	0.0	0.16
SC2140R	FC 2 H ₂ Flow Rate						
SC2141R	FC 3 H ₂ Flow Rate						

* See note, page 4-11

A-152

TABLE 4.1
INSTRUMENTATION/CAUTION AND WARNING SUMMARY (Continued)

MEASUREMENT NUMBER *	MEASUREMENT NAME	RANGE	ACCURACY		BIT VALUE	CAUTION AND WARNING SETTINGS	
			PERCENT	ACTUAL		LOW	HIGH
SC2142R	FC 1 O ₂ Flow Rate	0-1.6 lb/hr	±10.0	±0.160 lb/hr	0.0063	0.0	1.27
SC2143R	FC 2 O ₂ Flow Rate						
SC2144R	FC 3 O ₂ Flow Rate						
SC0030Q	H ₂ Tank 1 Qty	0-100%	±2.68	2.68 %	0.4%	—	—
SC0031Q	H ₂ Tank 2 Qty						
SC0032Q	O ₂ Tank 1 Qty	0-100%	±2.68	2.68%	0.4%	—	—
SC0033Q	O ₂ Tank 2 Qty						
SC0037P	O ₂ Tank 1 Press	50-1050 psia	±2.68	±26.8 psia	4.23	800	950
SC0038P	O ₂ Tank 2 Press						
SC0039P	H ₂ Tank 1 Press	0-350 psia	±2.68	±9.38 psia	1.48	220	270
SC0040P	H ₂ Tank 2 Press						
SC0041T	O ₂ Tank 1 Temp	-320 to +80 ⁰ F	±2.68	±10.85 ⁰ F	1.57	—	—
SC0042T	O ₂ Tank 2 Temp						
SC0043T	H ₂ Tank 1 Temp	-420 to -200 ⁰ F	±2.68	±6.03 ⁰ F	0.867	—	—
SC0044T	H ₂ Tank 2 Temp						

* See note, page 4-11

TABLE 4.1
INSTRUMENTATION/CAUTION AND WARNING SUMMARY (Continued)

MEASUREMENT NUMBER *	MEASUREMENT NAME	RANGE	ACCURACY		BIT VALUE	CAUTION AND WARNING SETTINGS	
			PERCENT	ACTUAL		LOW	HIGH
SC2160X	FC1 pH High	Normal - High	—	—	Event	—	—
SC2161X	FC2 pH High	Normal - High	—	—	Event	—	—
SC2162X	FC3 pH High	Normal - High	—	—	Event	—	—
**SC0050Q	H ₂ Tank 3 Qty	0-100%					
**SC0051Q	O ₂ Tank 3 Qty	0-100%					
**SC0052P	H ₂ Tank 3 Press.	0-350 psia					
**SC0053P	O ₂ Tank 3 Press.	50-1050 psia					

* See note, page A-160
** CSM 112 through 115 only

TABLE 4.2
GROUND TEST INSTRUMENTATION

MEASUREMENT NUMBER *	MEASUREMENT NAME	RANGE	BIT VALUE
SC2120X **	FC 1 Bus A	—	—
SC2121X **	FC 2 Bus A	—	—
SC2122X **	FC 3 Bus A	—	—
SC2125X **	FC 1 Bus B	—	—
SC2126X **	FC 2 Bus B	—	—
SC2127X **	FC 3 Bus B	—	—
SC0092X	Pressure low O ₂ tanks 1 & 2	Normal - Low	Event
SC0093X	Motor Switch Close O ₂ tanks 1&2	Open - Close	Event
SC0094X	Pressure low H ₂ tanks 1 & 2	Normal - Low	Event
SC0095X	Motor Switch Close H ₂ Tanks 1&2	Open - Close	Event
SC0360V	Fan Motor Oper Tank 1 O ₂	—	—
SC0361V	Fan Motor Oper Tank 2 O ₂	—	—

* See note, page A-160

** Data also displayed to crew

TABLE 4.2
GROUND TEST INSTRUMENTATION (Continued)

MEASUREMENT NUMBER *	MEASUREMENT NAME	RANGE	VALUE
SC0362V	Fan Motor Oper Tank 1 H ₂	—	—
SC0363V	Fan Motor Oper Tank 2 H ₂	—	—
SC2075X	FC H ₂ Inline Htr ON	ON	Event
SC2076X	FC H ₂ Inline Htr OFF	OFF	Event
SC2116V	FC 1 DC Volts Out	25-40 volts	0.059
SC2117V	FC 2 DC Volts Out	25-40 volts	0.059
SC2118V	FC 3 DC Volts Out	25-40 volts	0.059
SC2130X	FC 1 H ₂ Purge Valve Oper	Close - Open	Event
SC2131X	FC 2 H ₂ Purge Valve Oper	Close - Open	Event
SC2132X	FC 3 H ₂ Purge Valve Oper	Close - Open	Event

* See note, page A-160

TABLE 4.2
GROUND TEST INSTRUMENTATION (Continued)

MEASUREMENT NUMBER *	MEASUREMENT NAME	RANGE	BIT VALUE
SC2133X	FC 1 O ₂ Purge Valve	Close - Open	Event
SC2134X	FC 2 O ₂ Purge Valve	Close - Open	Event
SC2135X	FC 3 O ₂ Purge Valve	Close - Open	Event
SC2326X **	FC 1 O ₂ /H ₂ Shutoff Valve Open Hold	Off - Hold	Event
SC2327X **	FC 2 O ₂ /H ₂ Shutoff Valve Open Hold	Off - Hold	Event
SC2328X **	FC 3 O ₂ /H ₂ Shutoff Valve Open Hold	Off - Hold	Event
GC5000V	FC 1 Htr Voltage Zone 1	0-120 vrms	0.472
GC5001V	FC 1 Htr Voltage Zone 2		
GC5002V	FC 1 Htr Voltage Zone 3		

* See note, page A-160

** Data also displayed to crew

TABLE 4.2
GROUND TEST INSTRUMENTATION (Continued)

MEASUREMENT NUMBER *	MEASUREMENT NAME	RANGE	BIT VALUE
GC5003V	FC 2 Htr Voltage Zone 1	0-120 vrms	0.472
GC5004V	FC 2 Htr Voltage Zone 2		
GC5005V	FC 2 Htr Voltage Zone 3		
GC5006V	FC 3 Htr Voltage Zone 1	0-120 vrms	0.472
GC5007V	FC 3 Htr Voltage Zone 2		
GC5008V	FC 3 Htr Voltage Zone 3		
GC5009C	FC 1 Htr Current Zone 1	0-5 arms	0.0197
GC5010C	FC 1 Htr Current Zone 2	0-50 arms	0.197
GC5011C	FC 1 Htr Current Zone 3	0-5 arms	0.0197

* See note, page A-160

TABLE 4.2
GROUND TEST INSTRUMENTATION (Continued)

MEASUREMENT NUMBER *	MEASUREMENT NAME	RANGE	BIT VALUE
GC5012C	FC 2 Htr Current Zone 1	0-5 arms	0.0197
GC5013C	FC 2 Htr Current Zone 2	0-50 arms	0.197
GC5014C	FC 2 Htr Current Zone 3	0-5 arms	0.0197
GC5015C	FC 3 Htr Current Zone 1	0-5 arms	0.0197
GC5016C	FC 3 Htr Current Zone 2	0-50 arms	0.197
GC5017C	FC 3 Htr Current Zone 3	0-5 arms	0.0197
GC5019E	FC 1 Htr Power	0-5000 watts	19.7
GC5020E	FC 2 Htr Power		
GC5021E	FC 3 Htr Power		

* See note, page A-160

TABLE 4.1 NOTE

The measurement identification used in Table 4.1 consists of seven characters: two letters followed by four numbers and one letter as shown below.

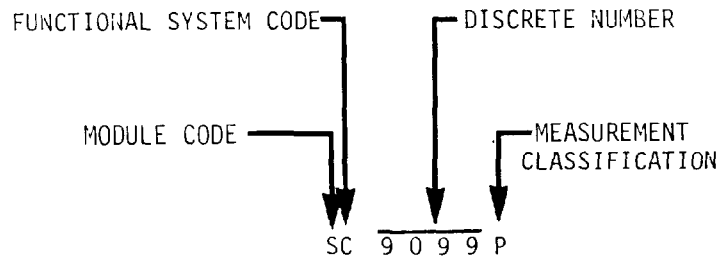

Module Code

The first letter designates the measurement location by module:

- C Command Module
- G GSE Auxiliary and Checkout Equipment
- S Service Module

Function Subsystem Code

The second letter denotes the subsystem within which the measurement originates:

- C Electrical Power

Discrete Number

Characters three through six are discrete numbers listed sequentially within each system.

Measurement Classification

The seventh character, a letter, denotes measurement classification or type:

- | | | | |
|---|----------|---|----------------|
| C | Current | R | Rate |
| E | Power | T | Temperature |
| P | Pressure | V | Voltage |
| Q | Quantity | X | Discrete Event |

5.0 FUEL CELL/CRYOGENIC SUBSYSTEM MALFUNCTION PROCEDURES

The procedures describe the proper order and nature of emergency steps the crew must perform to determine the source of a fuel cell or cryogenic storage system problem/malfunction. A Caution and Warning alarm and light or abnormal instrumentation indication is evaluated by a malfunction procedure logic diagram. The logic diagrams enable the crew to determine the source of the problem and corrective actions, if required. Fuel cell shutdown and bus short isolation (not related to Caution and Warning) procedures are also presented as part of the malfunction procedures.

The procedures are primarily used as a guide for the flight crew to locate a problem and are presented for the flight monitor as a guide to the crew actions.

The source of the data was CSM 108 (Apollo 12) Flight Malfunction Procedures.

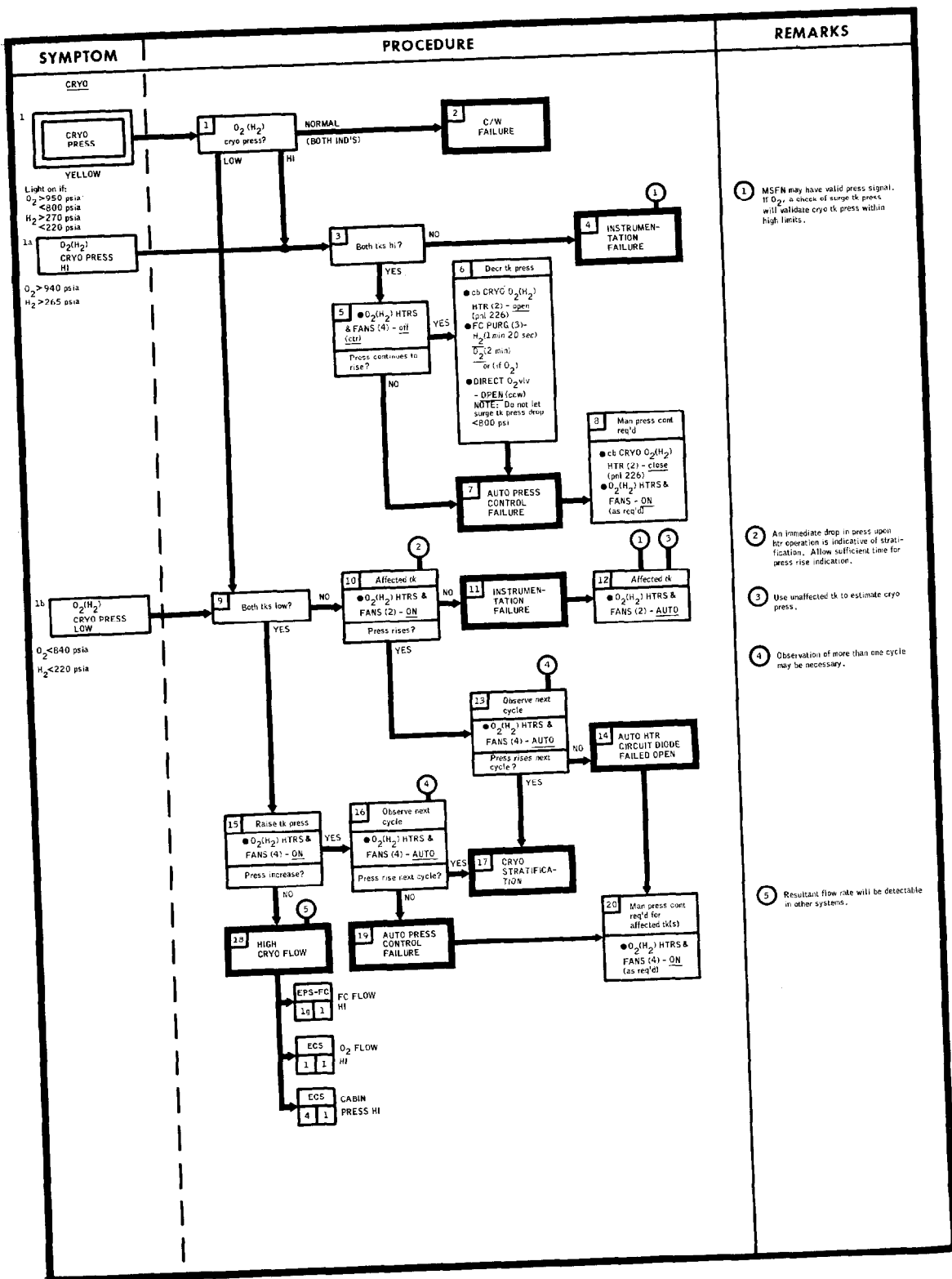

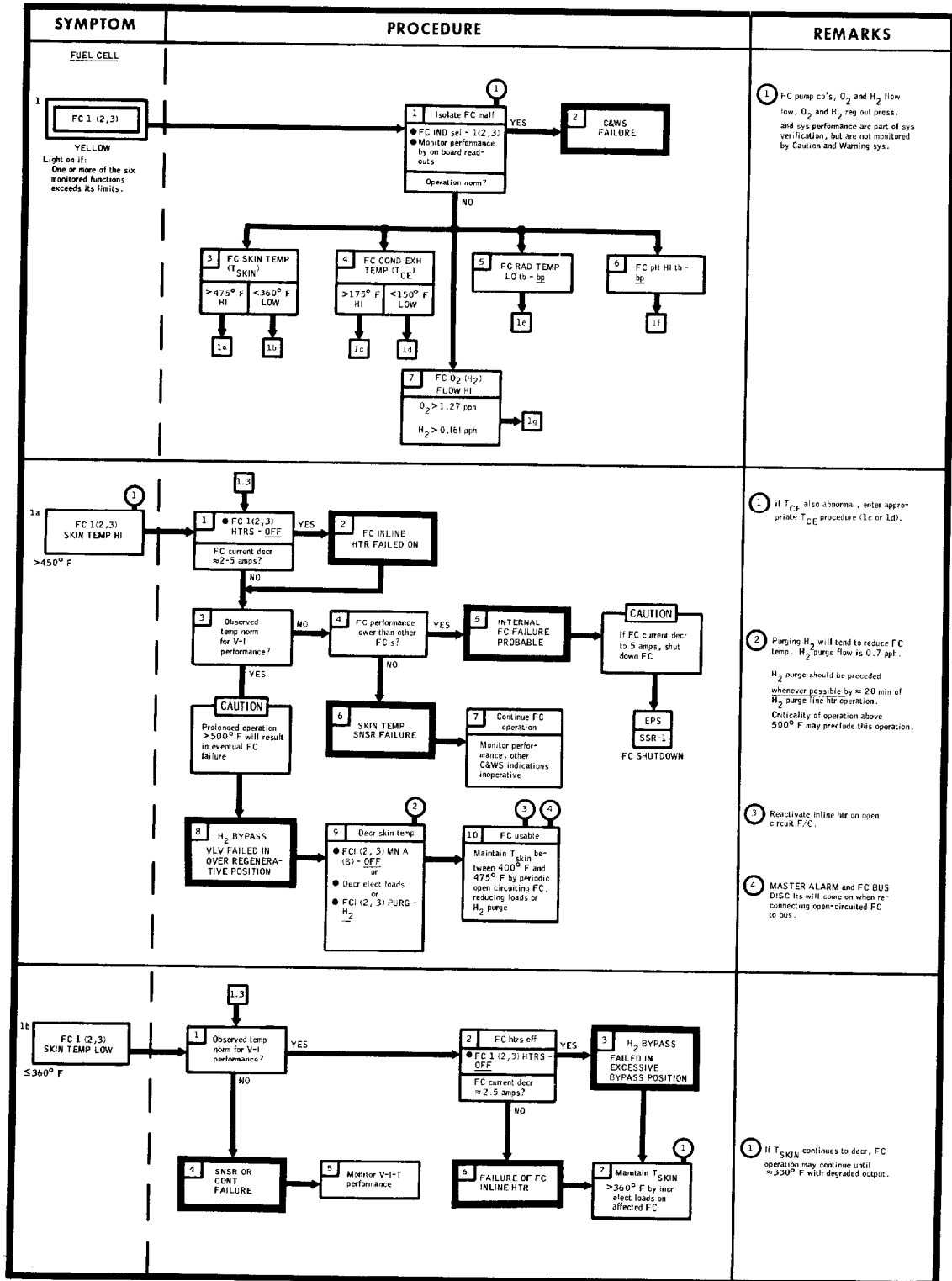

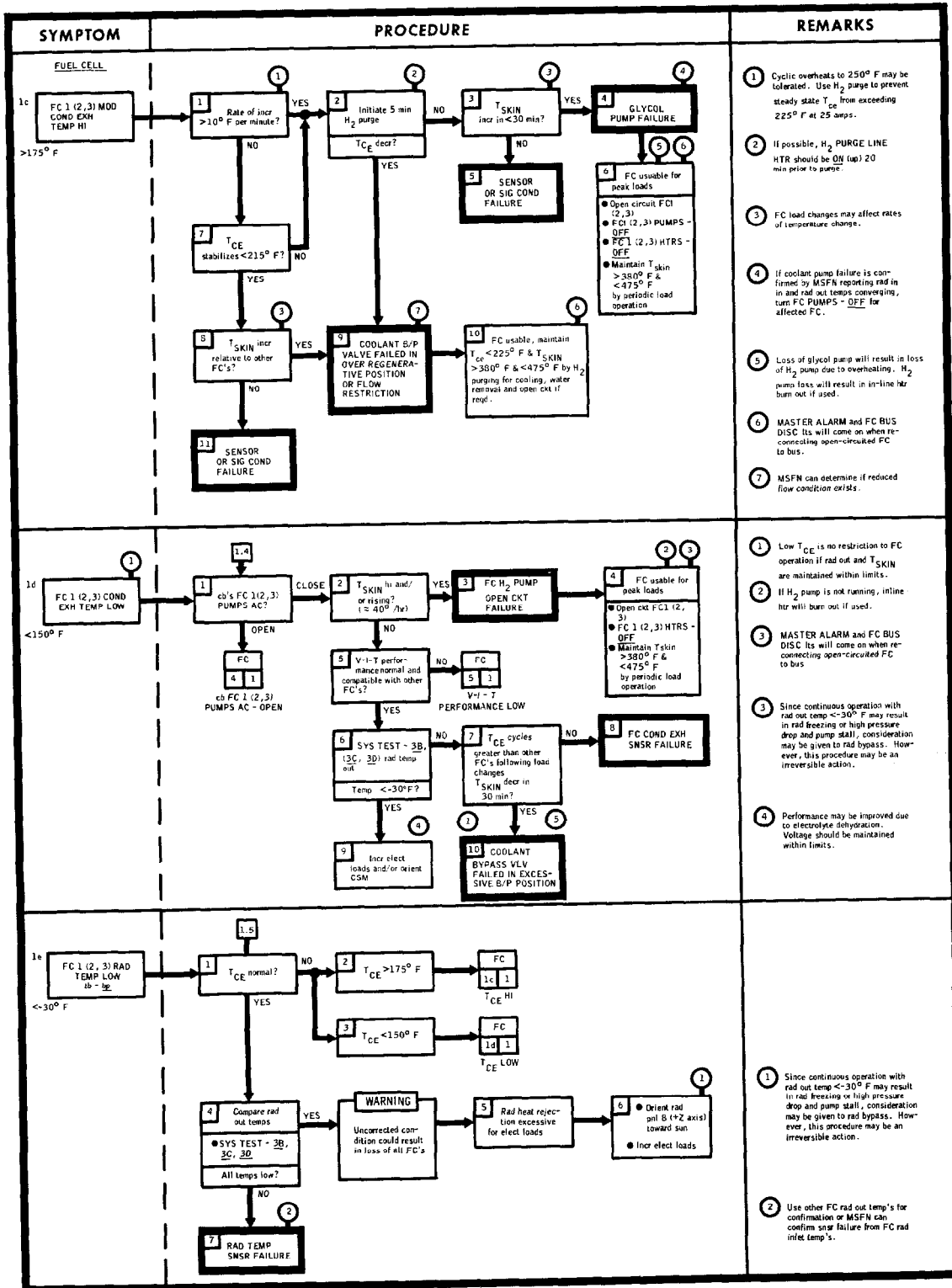

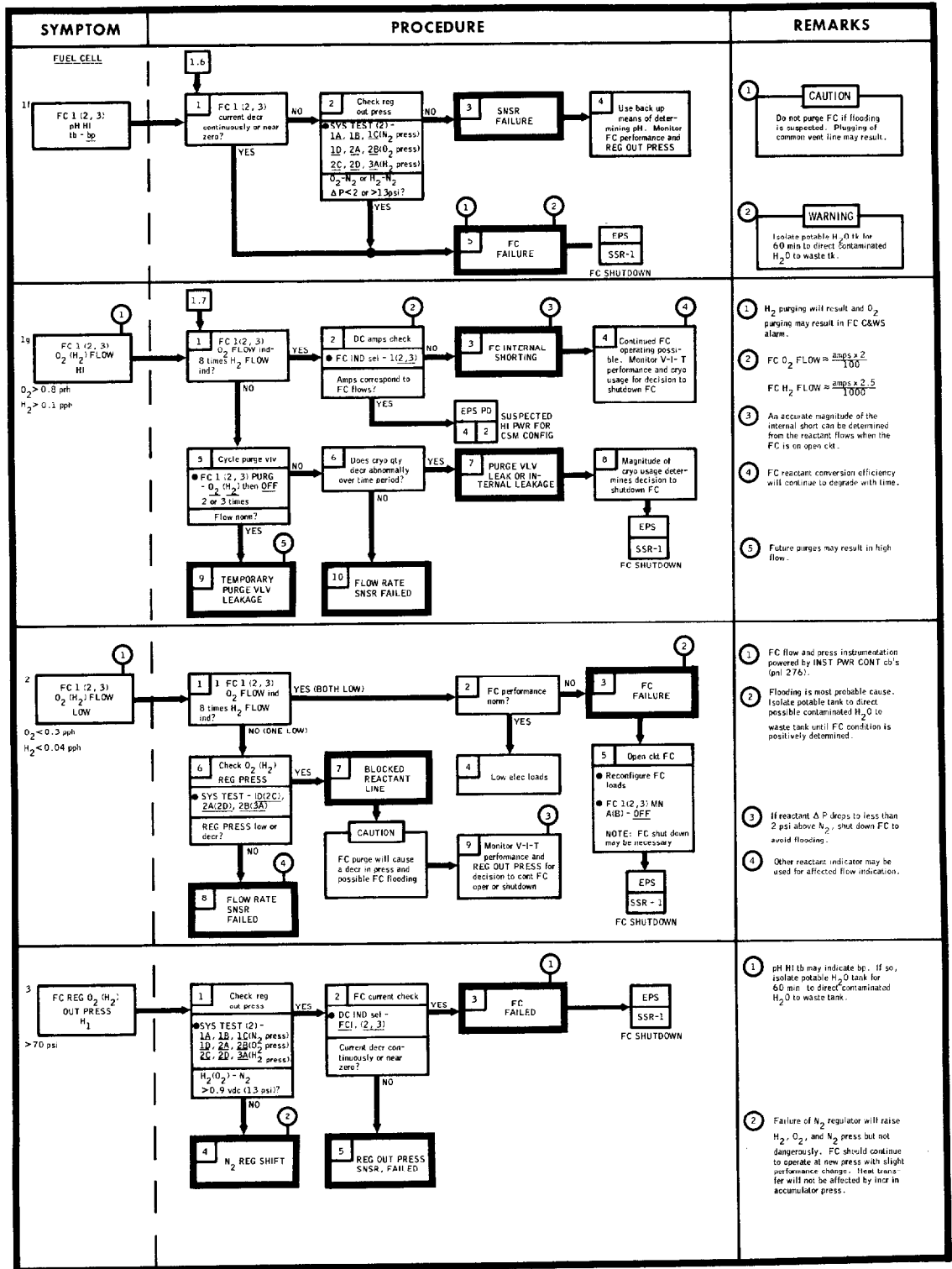

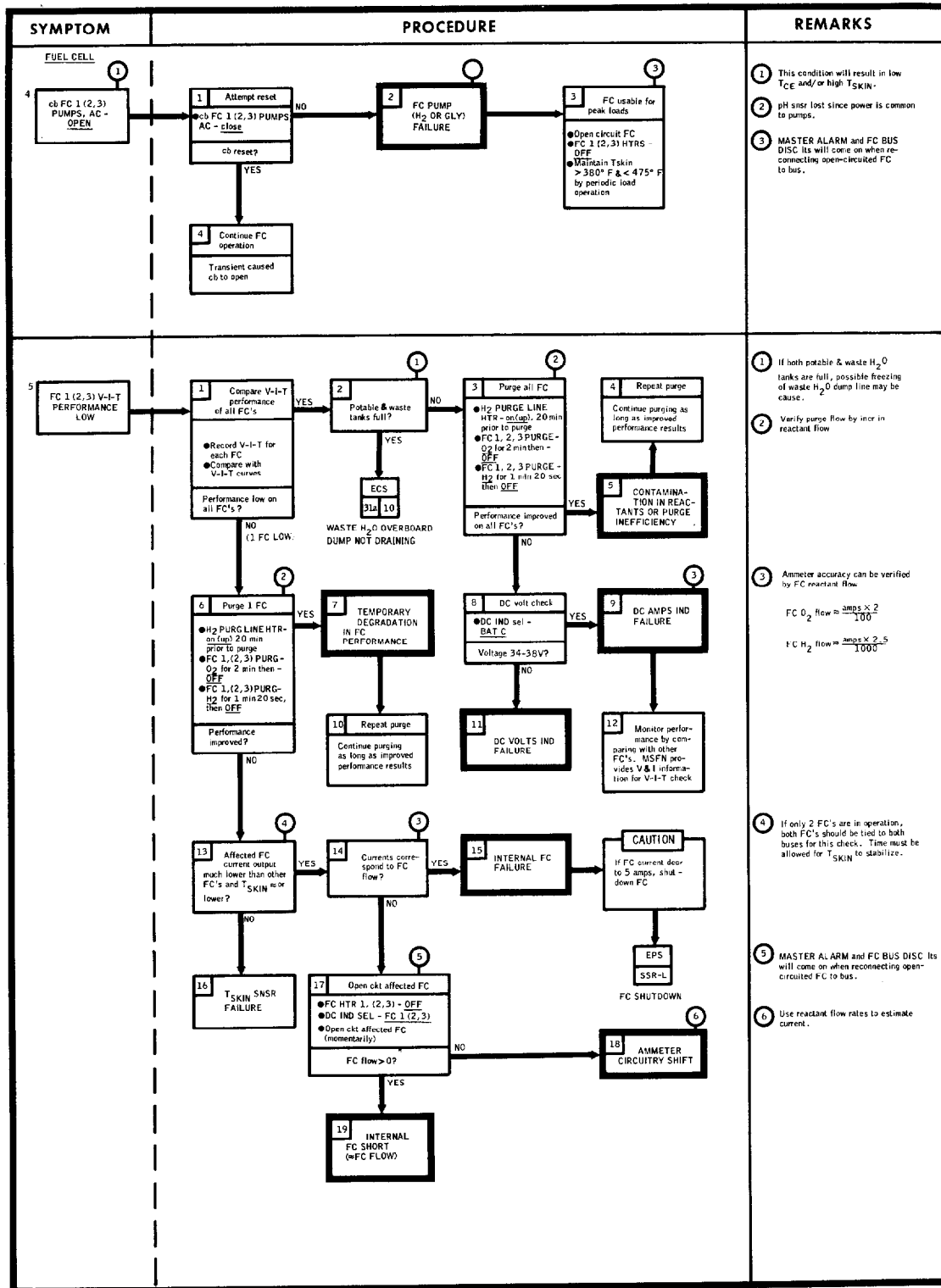

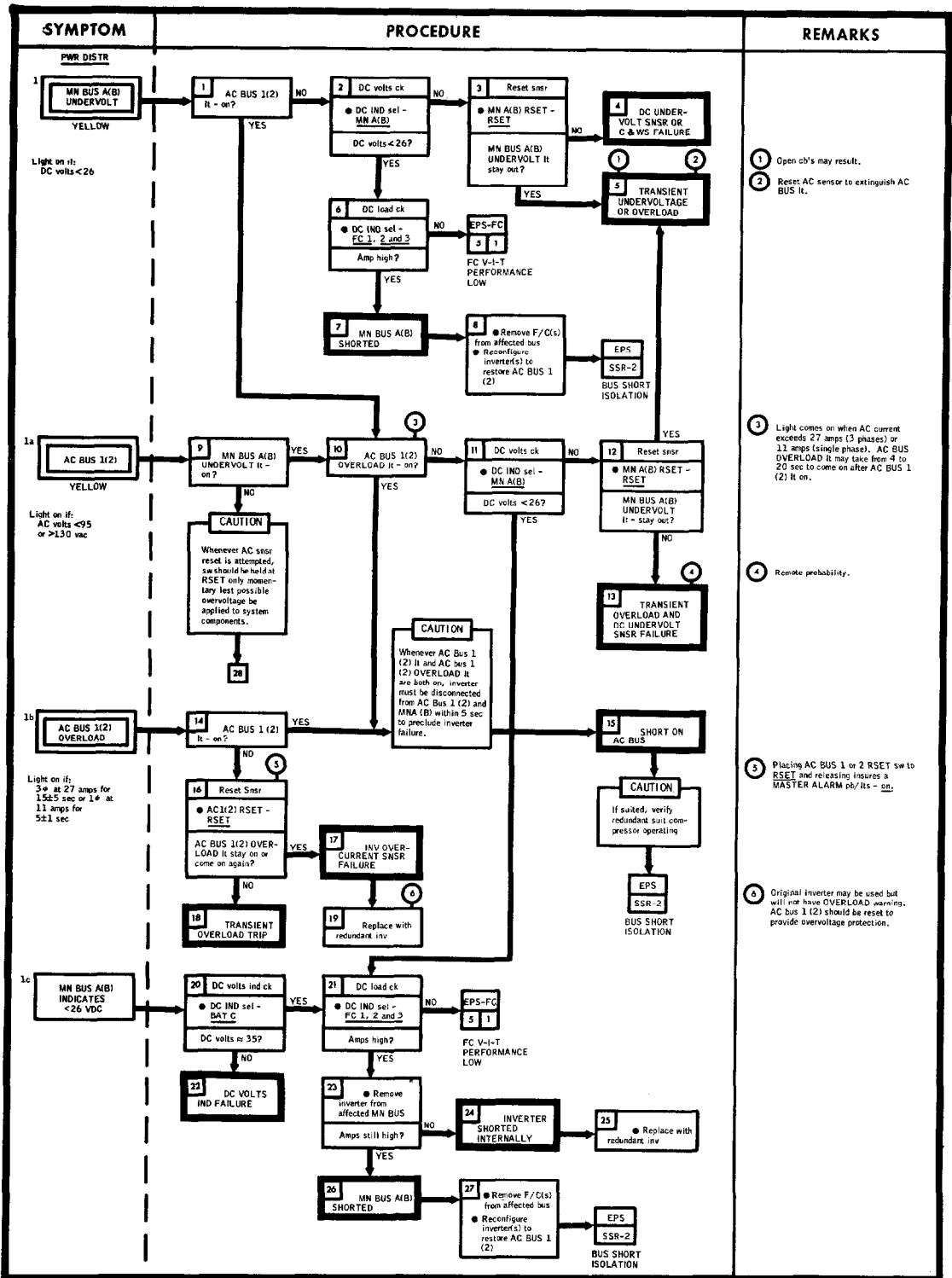

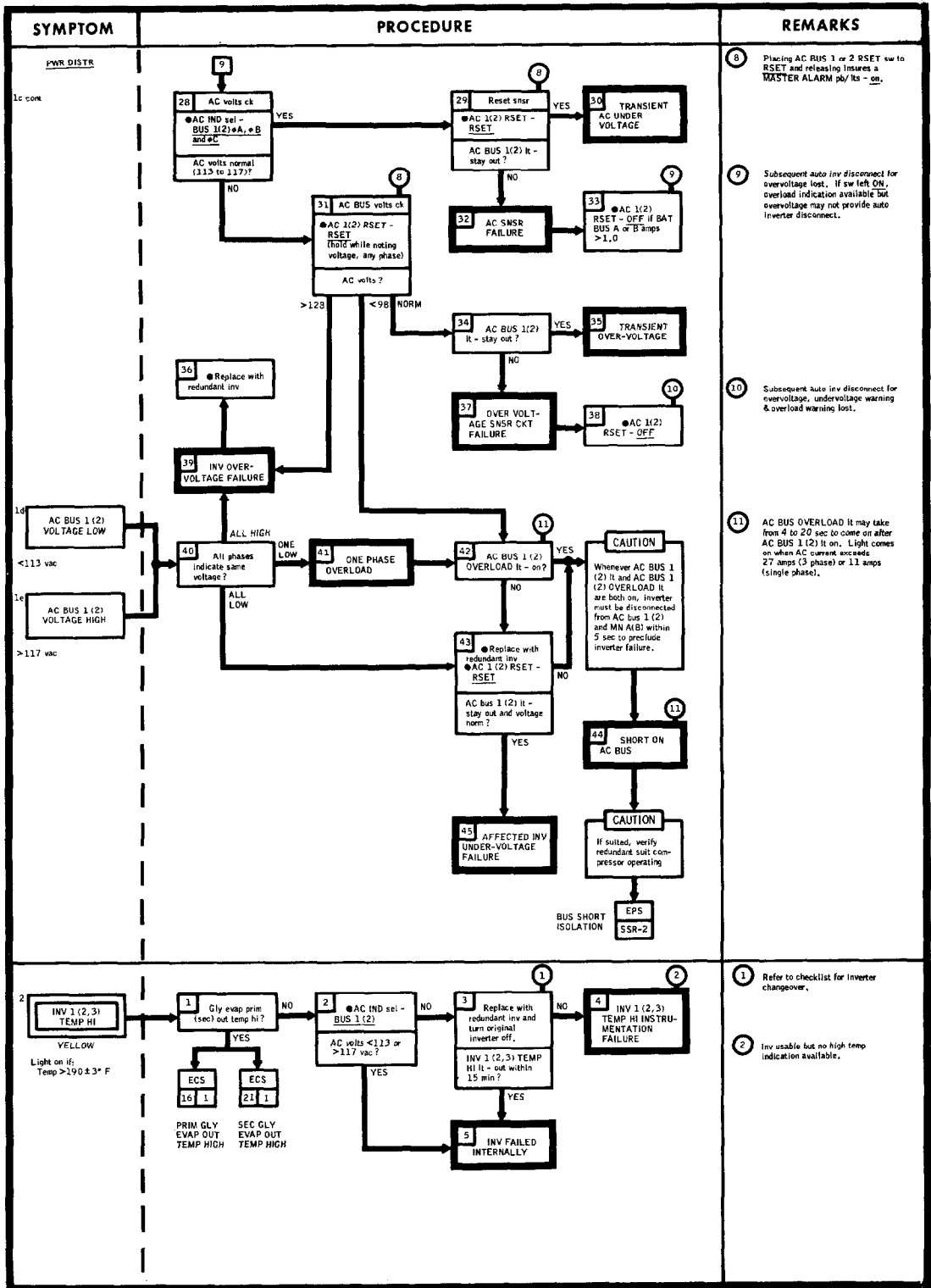

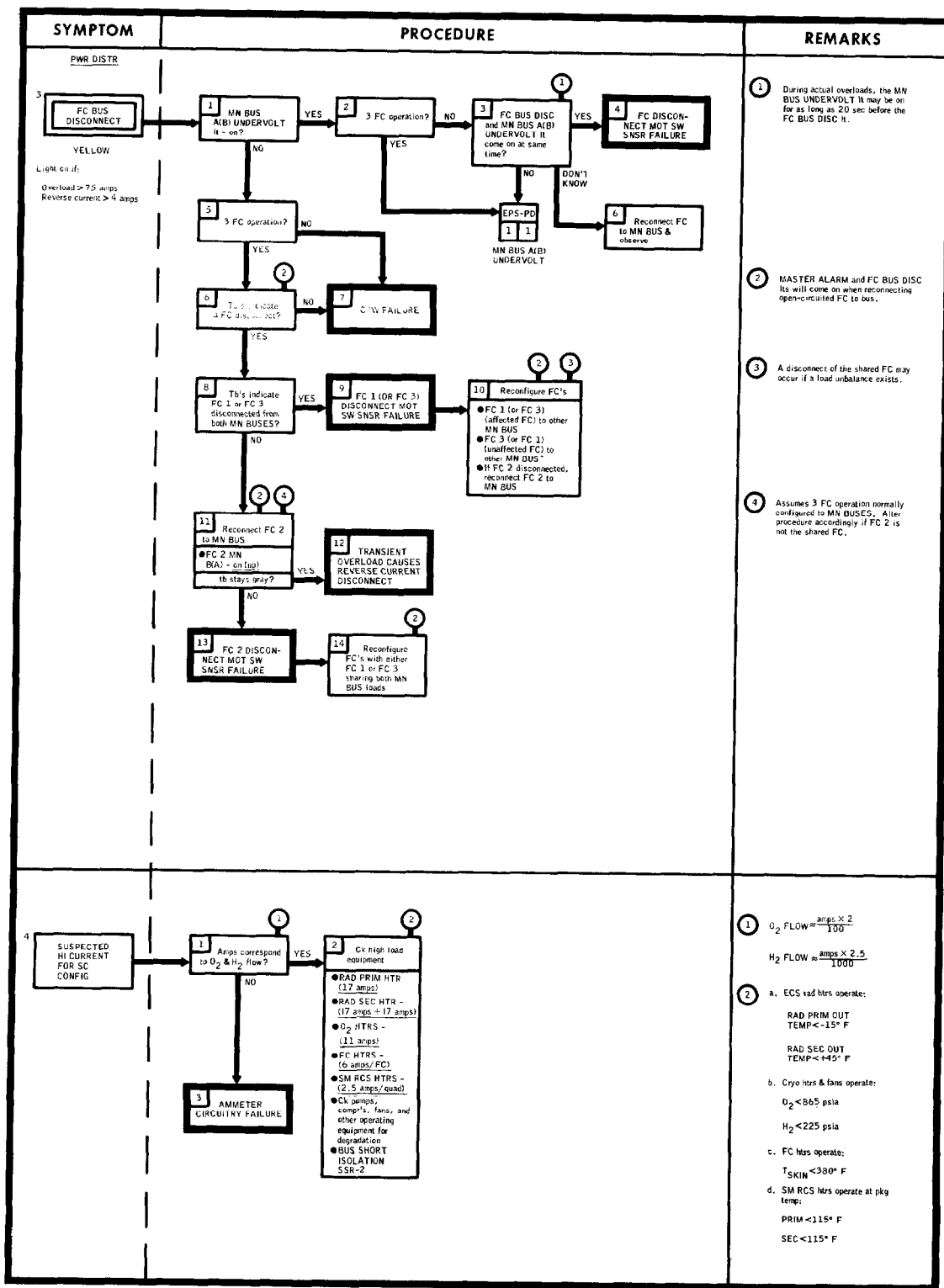

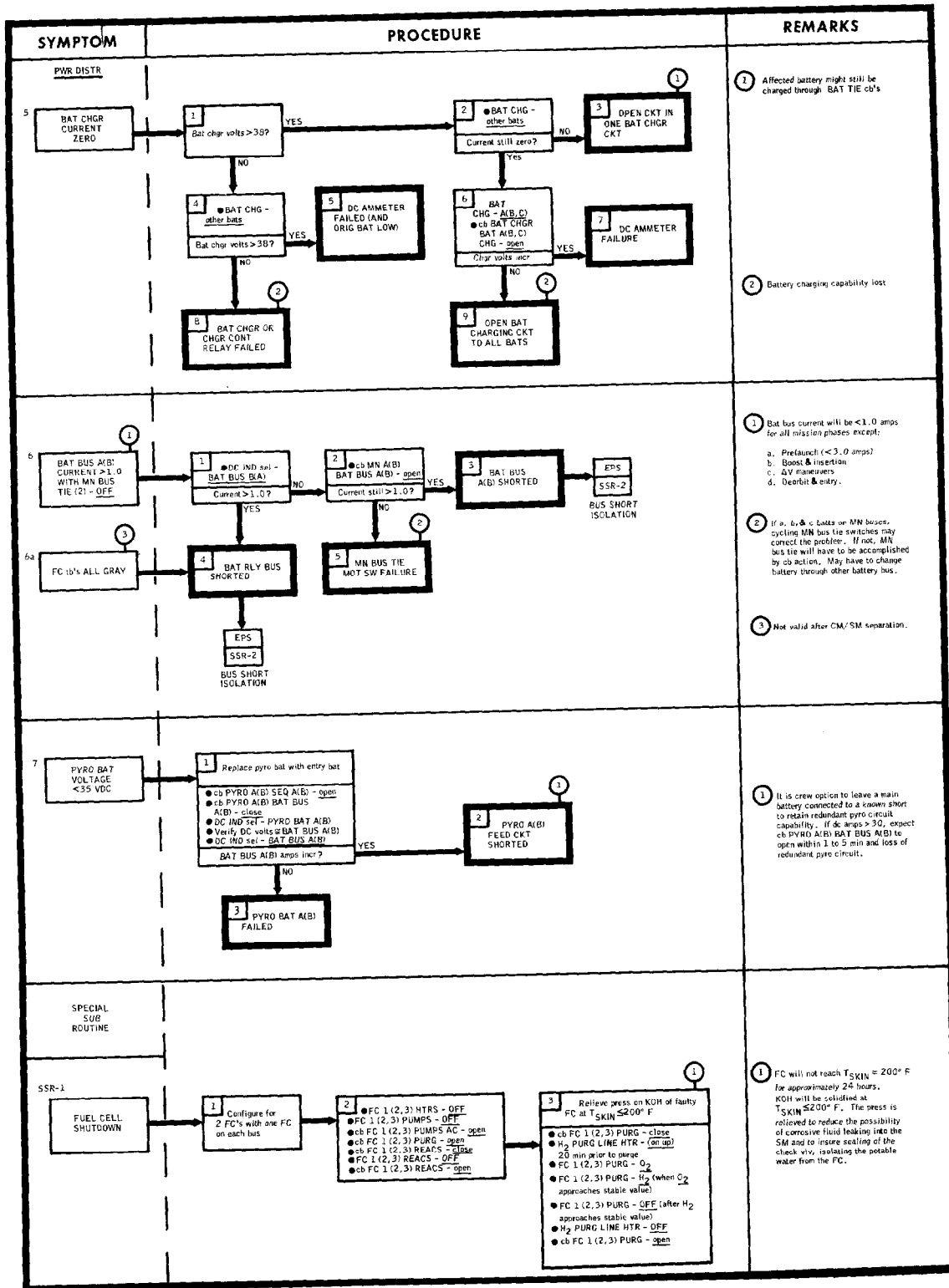

7.0 FUEL CELL/CRYOGENIC SUBSYSTEM HARDWARE DESCRIPTION

The fuel cell/cryogenic hardware description includes the subsystem isometric drawings, fluid schematics, component descriptions and filtration provisions.

Isometric drawings locate operational hardware; tubing runs, sizes and part numbers; and system interfaces. A schematic drawing of the Environmental Control System describes the water and oxygen system interfaces.

Fuel cell and cryogenic storage system schematics aid understanding of the system plumbing. These schematics are also used to reference to specific hardware component descriptions.

Filtration data describe the component protected, its minimum clearances and the filters rating, size, location and type.

Hardware descriptions are intended for rapid reference to the specific physical hardware affected as a result of a malfunction. Fuel cell/cryogenic subsystem interactions with interfacing components and subsystems are clarified by this background information.

The sources of the data included North American Rockwell Operational Checkout Procedures (OCP's), Pratt and Whitney Aircraft Fuel Cell Electrical Power Supply-PC3A-2 Support Manual, dated February 1, 1969, Pratt and Whitney Apollo Fuel Cell Component Descriptions, and Beech Aircraft Corporation Project Apollo Cryogenic Gas Storage Subsystem Flight Support Manual, dated September 6, 1968. The descriptions are applicable through CSM-115 including identified hardware changes for CSM 112-115. The configurations shown were current and correct as of December 1969.

7.1 SYSTEM HARDWARE ISOMETRIC
DRAWINGS AND SCHEMATIC

FUEL CELL/CRYOGENIC SUBSYSTEM LOCATION IN
SERVICE MODULE

H₂ RELIEF (HR)

C/M-S/M UMBILICAL

FUEL CELL SHELF

O₂ SUBSYSTEM
SHELF MODULE

H₂ TANKS

H₂ SUBSYSTEM
SHELF MODULE

BEAM NO. 4

BEAM NO. 3

VIEW LOOKING INBOARD SECTOR IV

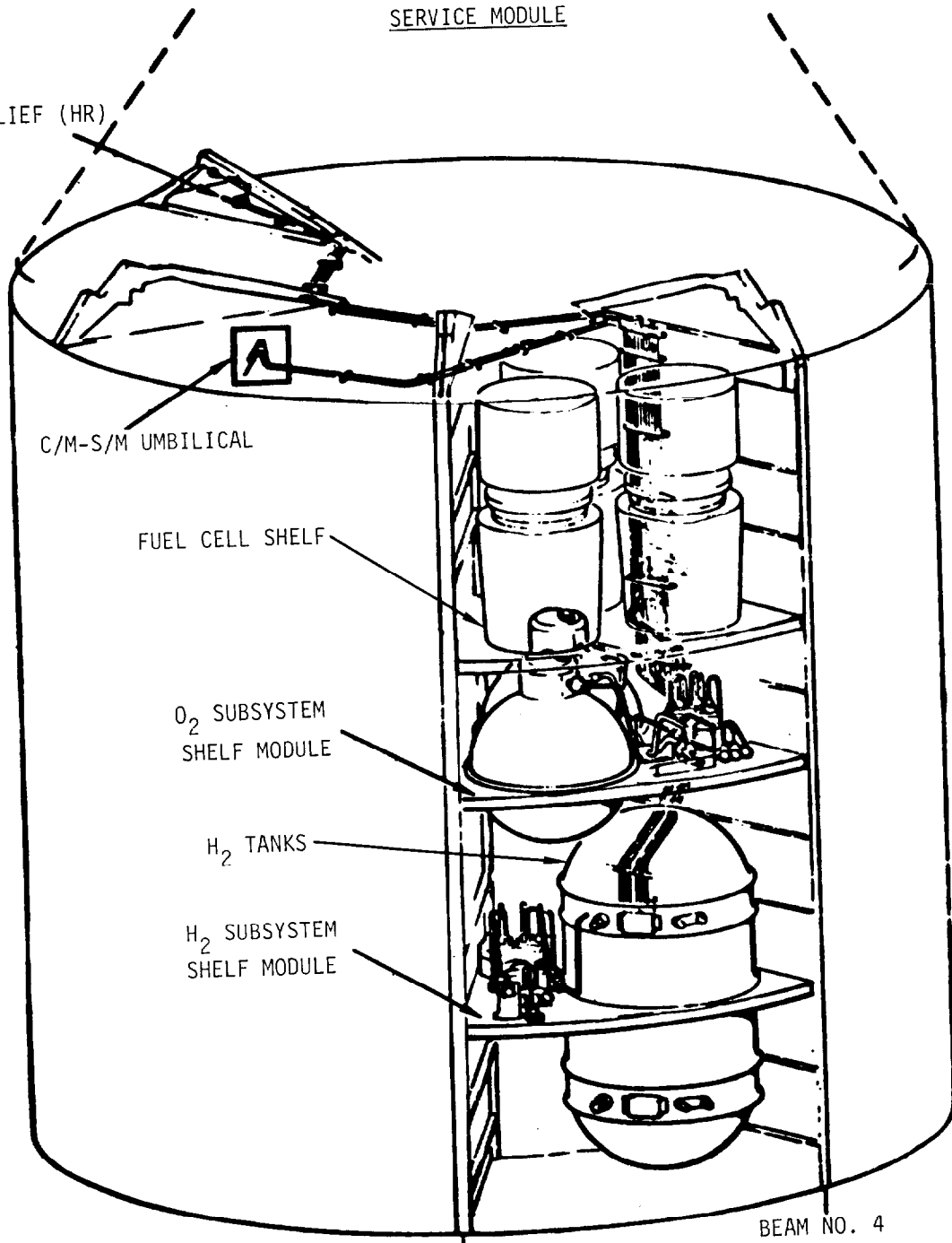

FUEL CELL SHELF INTERFACE

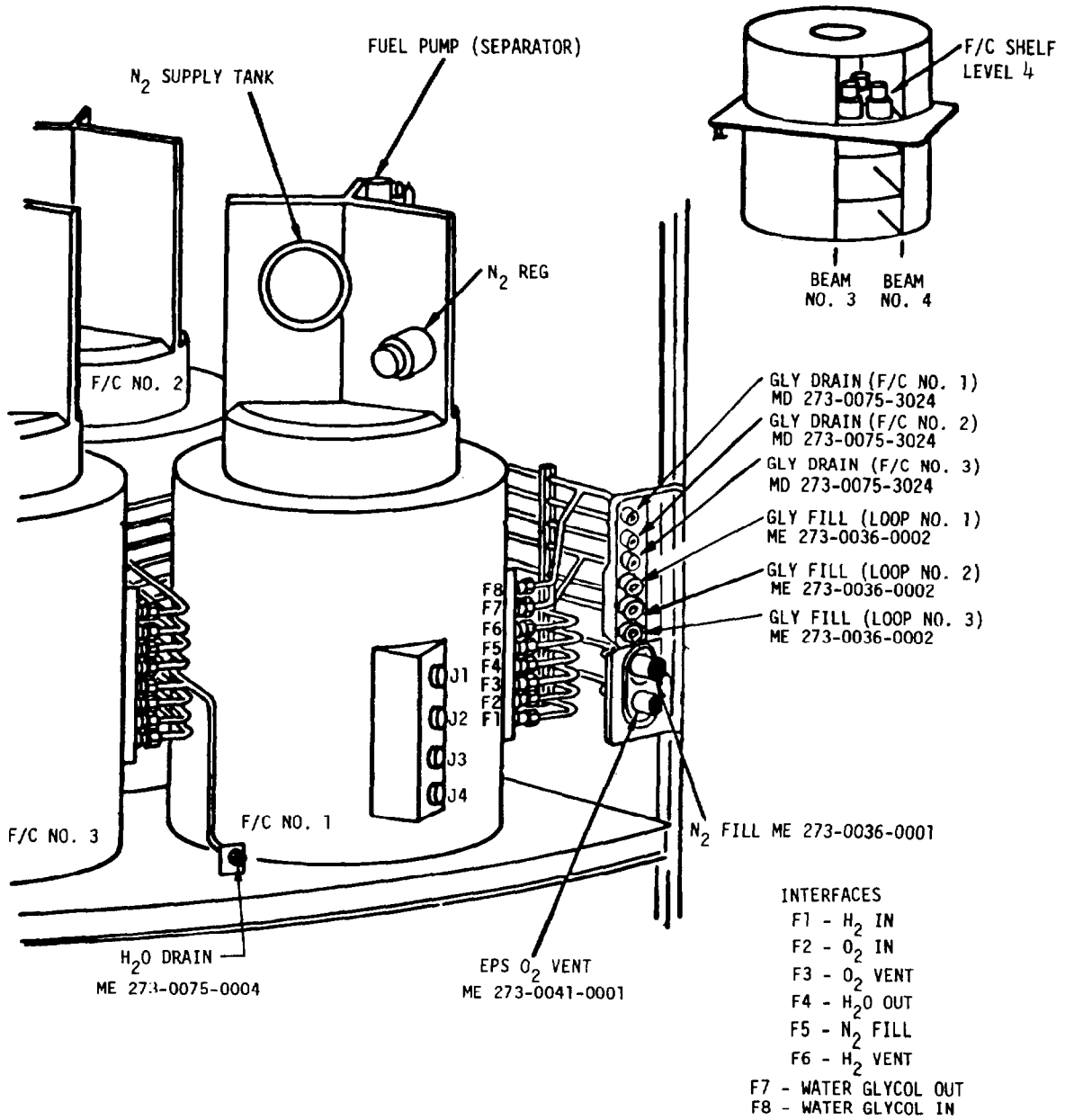

OXYGEN SUBSYSTEM SHELF MODULE

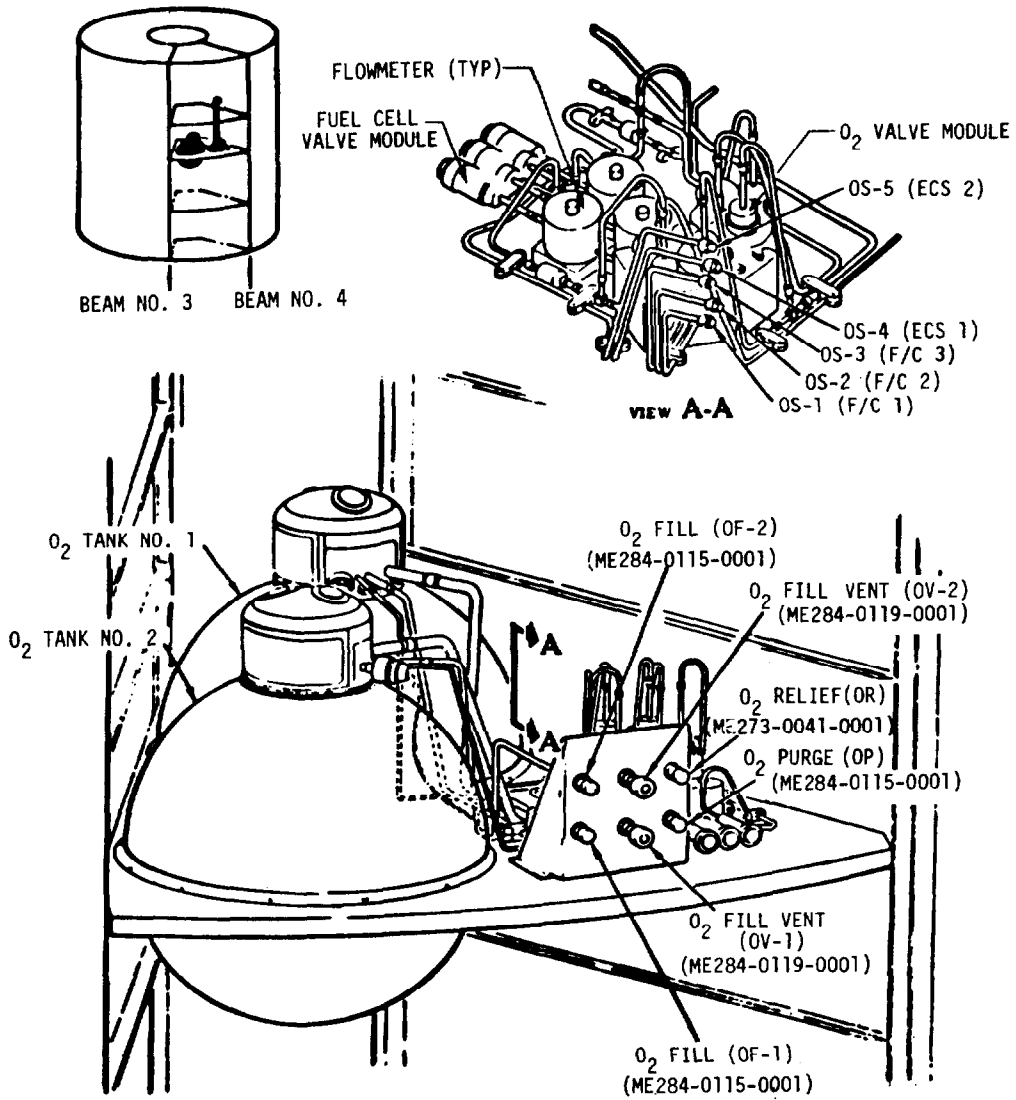

HYDROGEN SUBSYSTEM SHELF MODULE

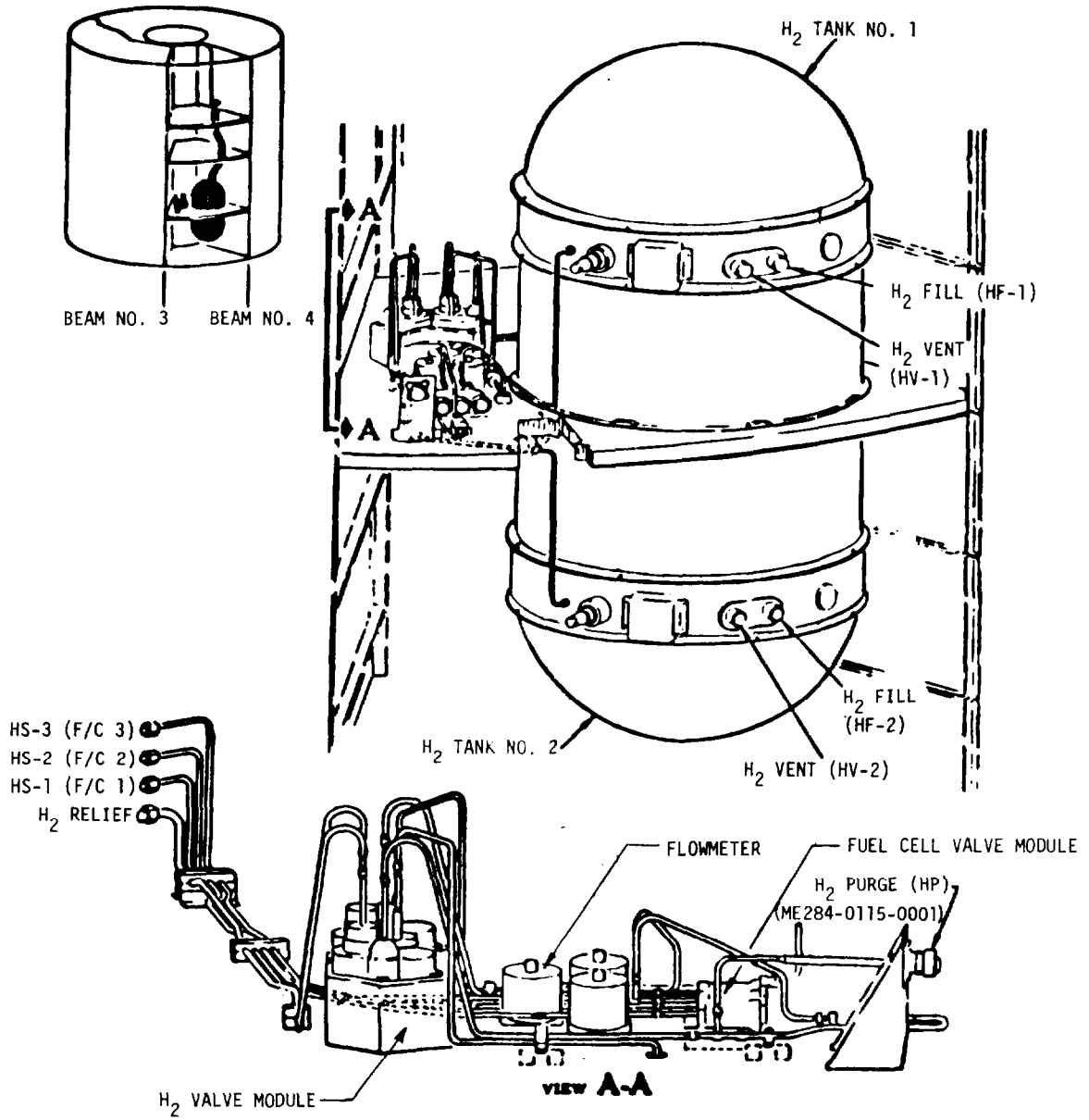

EPS WATER GLYCOL RADIATOR TEMPERATURE SENSOR LOCATION

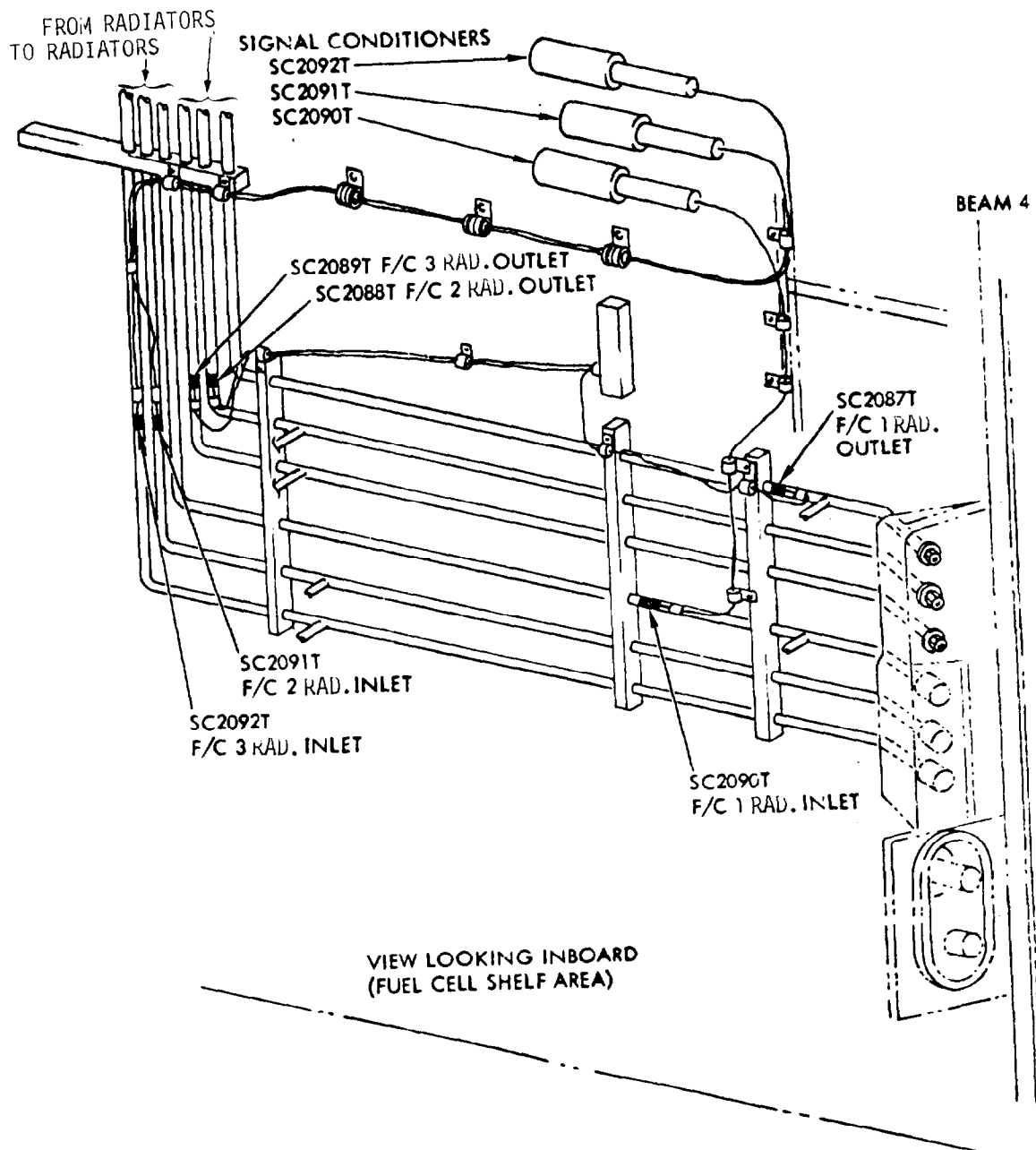

WATER GLYCOL SERVICE MODULE LINES

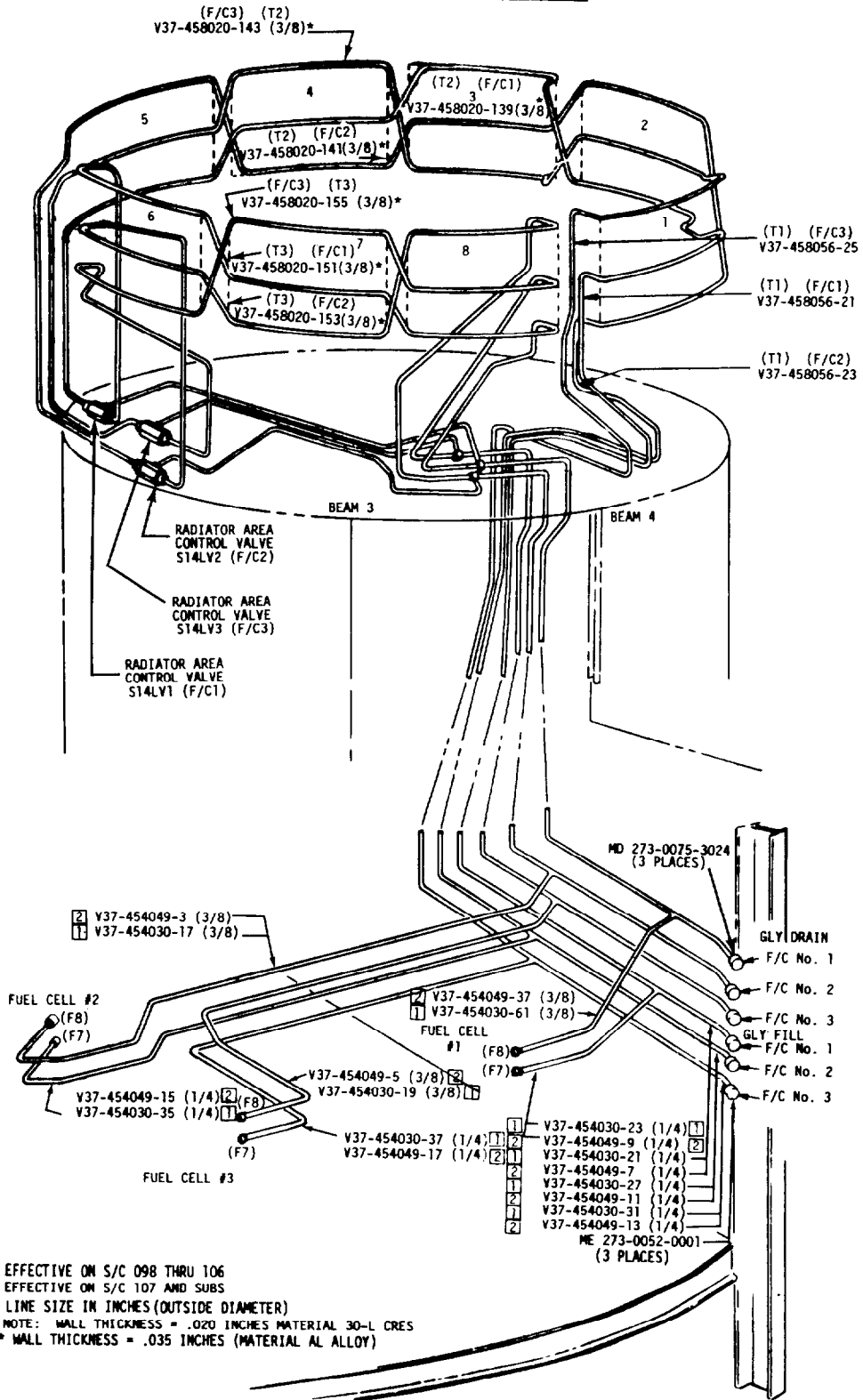

CRYOGENIC HYDROGEN SERVICE MODULE LINES

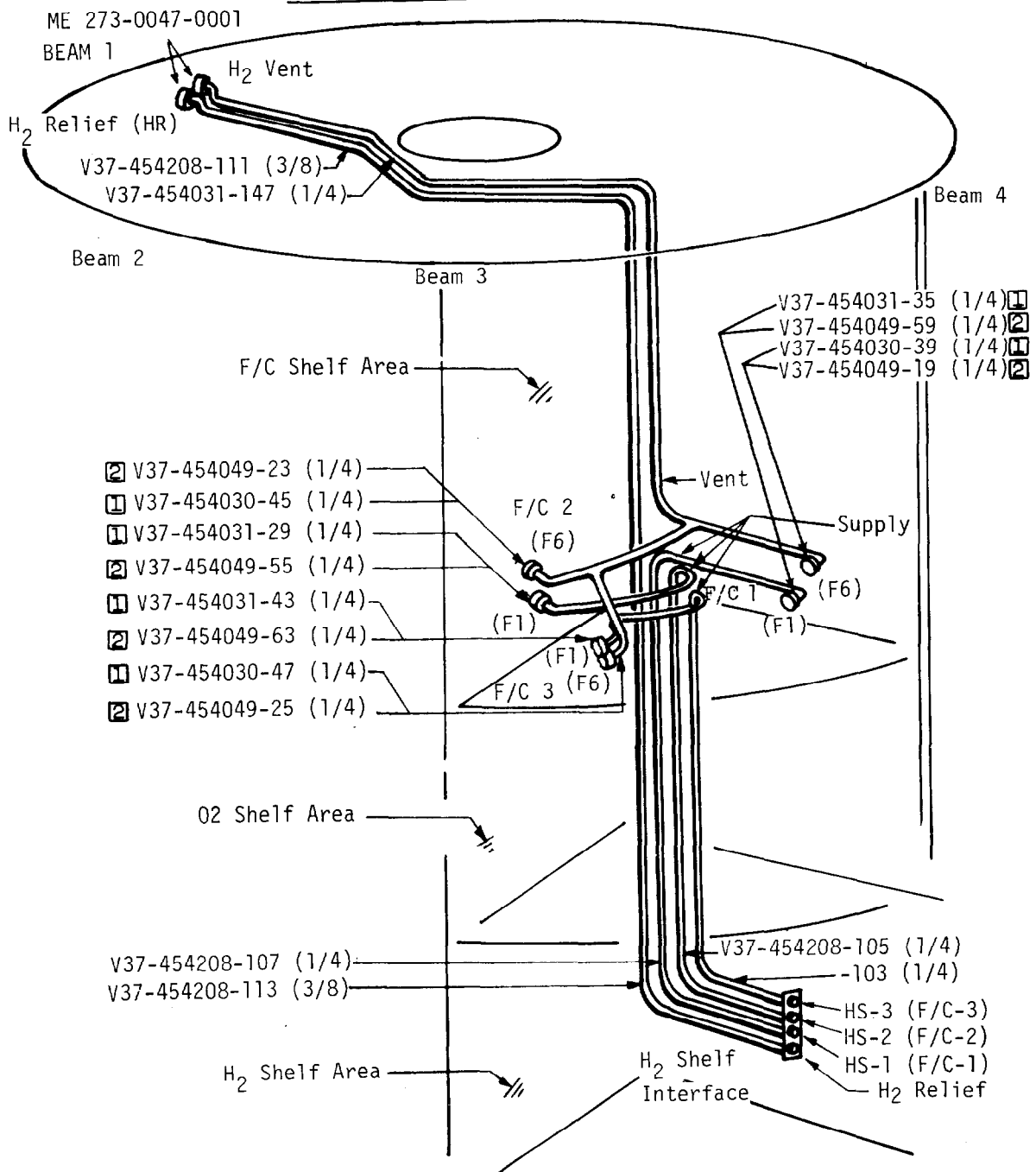

- 1 EFFECTIVE ON S/C 098 THRU 106
- 2 EFFECTIVE ON S/C 107 AND SUBS
- () LINE SIZE IN INCHES (OUTSIDE DIAMETER)
- NOTE: WALL THICKNESS = .020 INCHES

CRYOGENIC OXYGEN SERVICE MODULE LINES

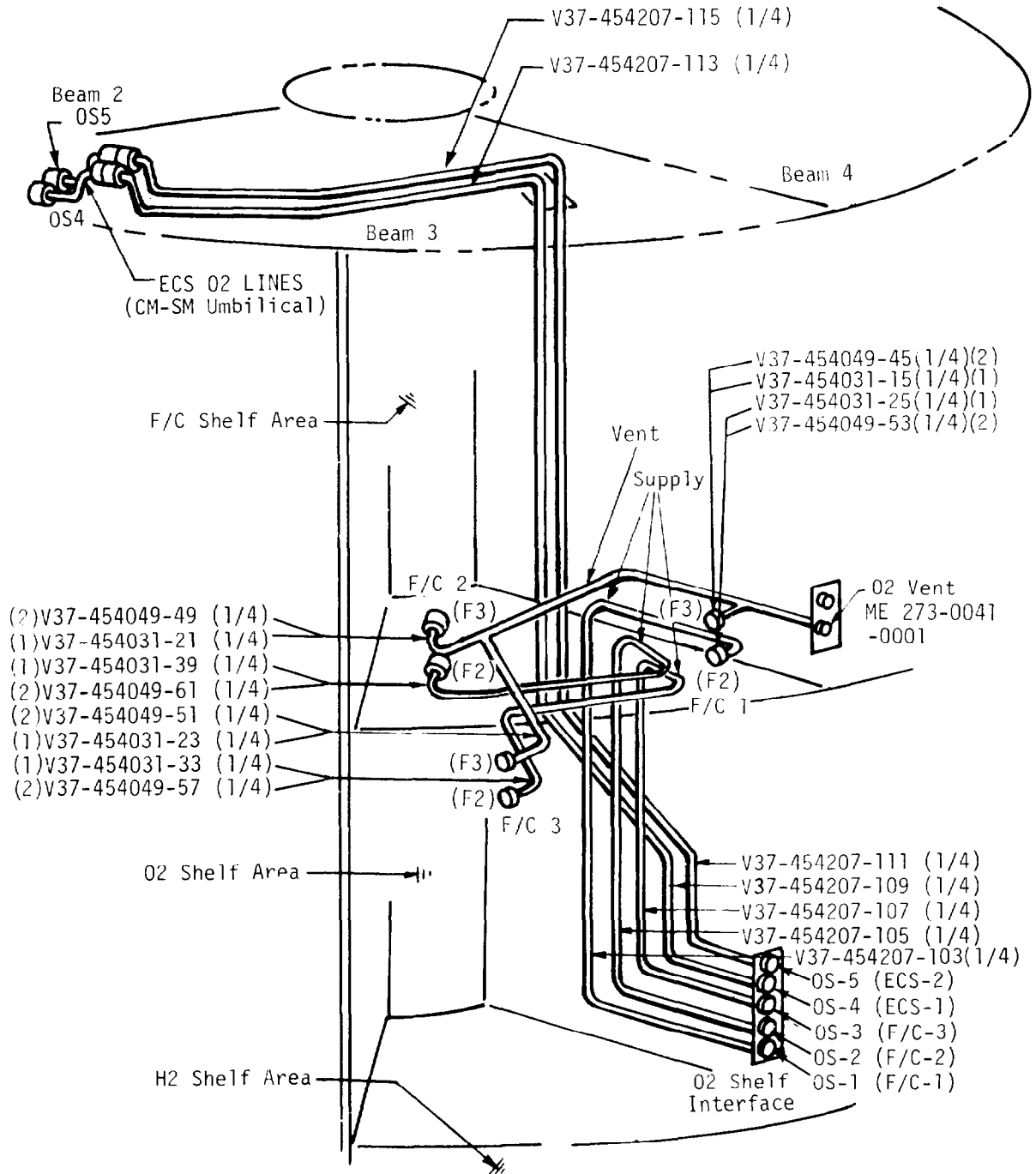

(1) EFFECTIVE ON S/C 098 THRU 106
 (2) EFFECTIVE ON S/C 107 AND SUBS
 () LINE SIZE IN INCHES (OUTSIDE DIAMETER)
 NOTE: WALL THICKNESS = .020 INCHES

FUEL CELL NITROGEN SERVICE MODULE LINES

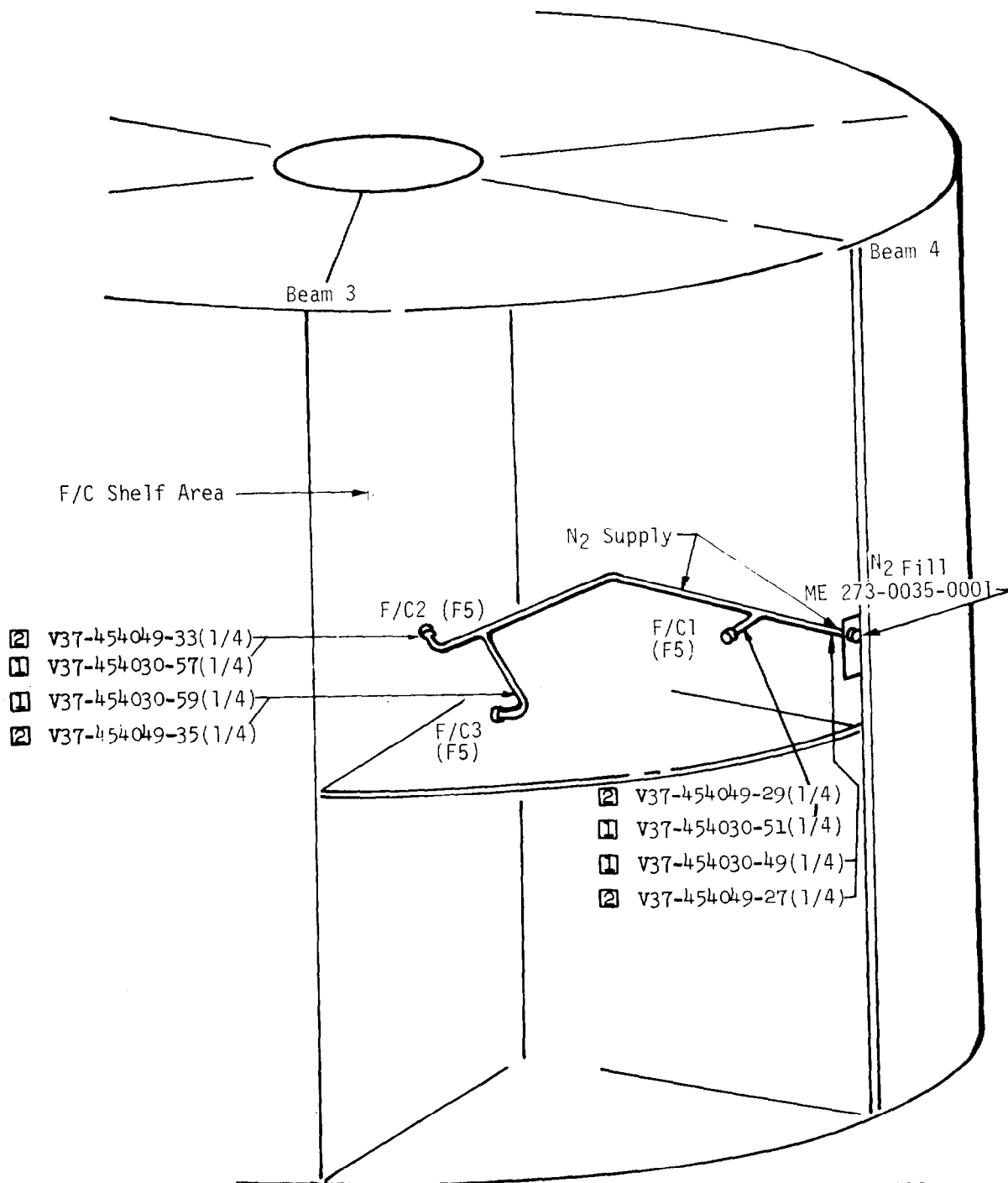

1 EFFECTIVE ON S/C 098 THRU 106
 2 EFFECTIVE ON S/C 107 AND SUBS
 () LINE SIZE IN INCHES (OUTSIDE
 DIAMETER)
 NOTE: WALL THICKNESS = .020 INCHES

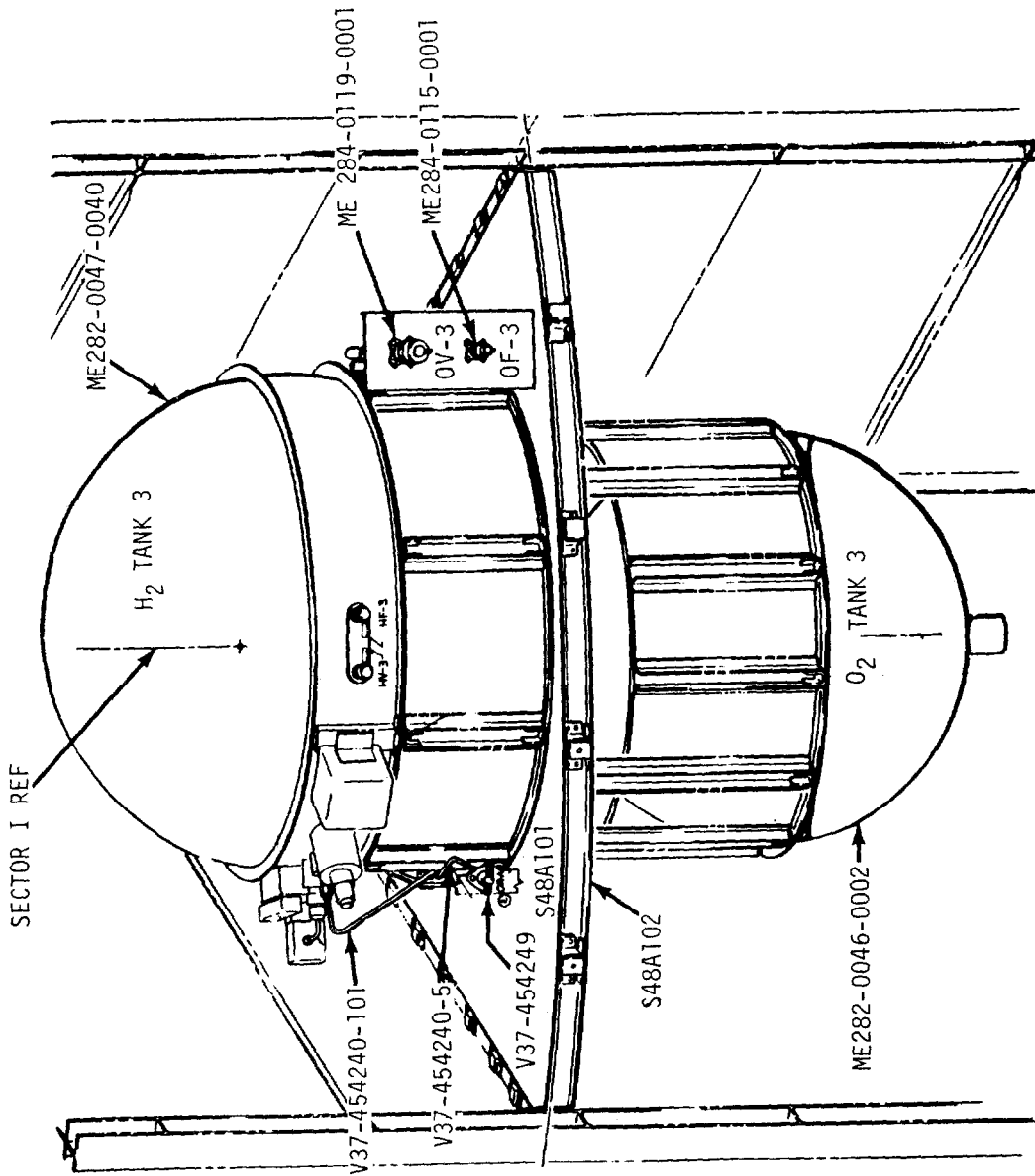

HYDROGEN/OXYGEN TANK SHELF MODULE - SECTOR I
EFFECTIVE ON CSM 112-115

A-185

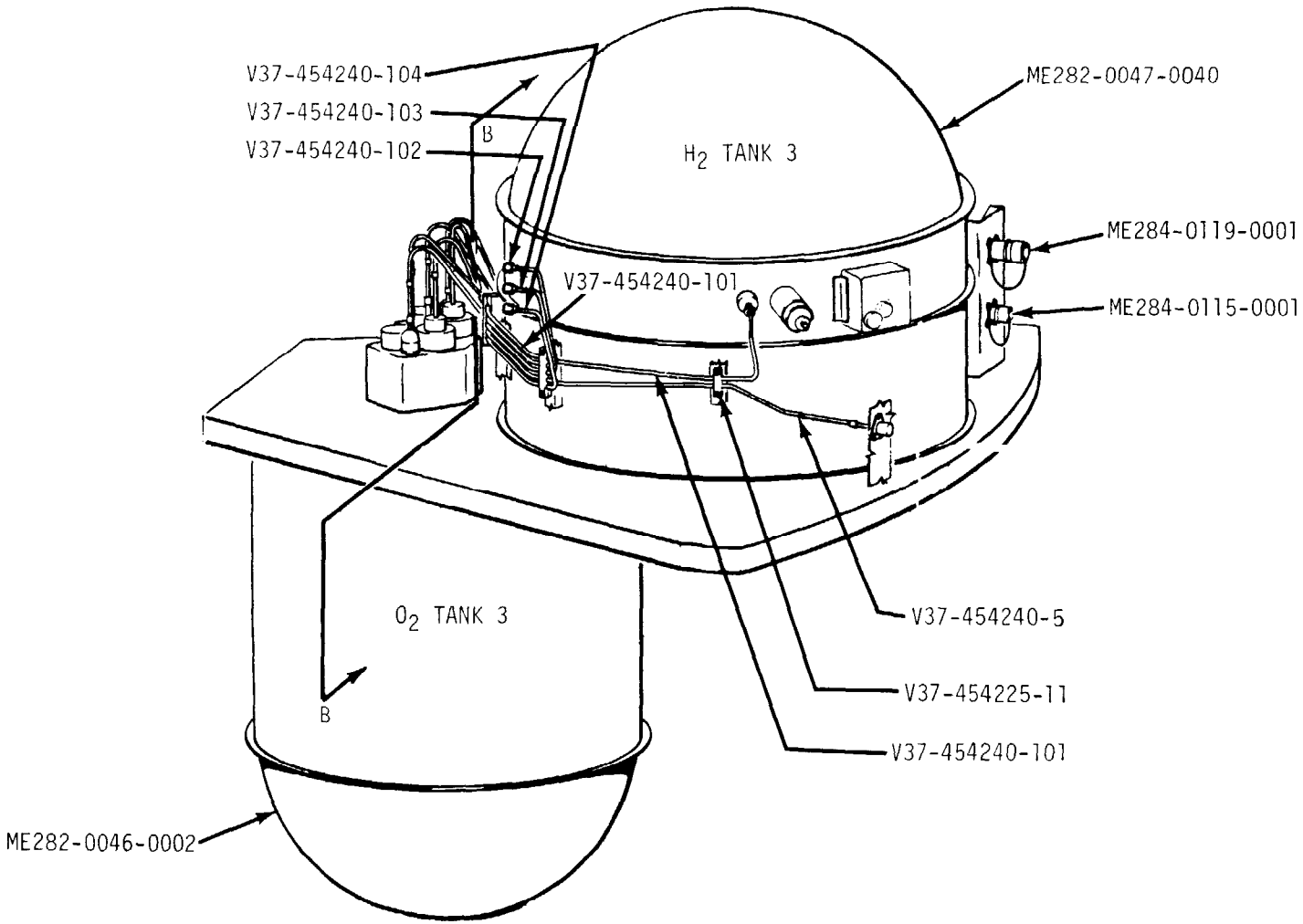

HYDROGEN/OXYGEN TANK SHELF MODULE - SECTOR I (SIDE VIEW - BEAM 6 SIDE)

EFFECTIVE ON CSM 112-115

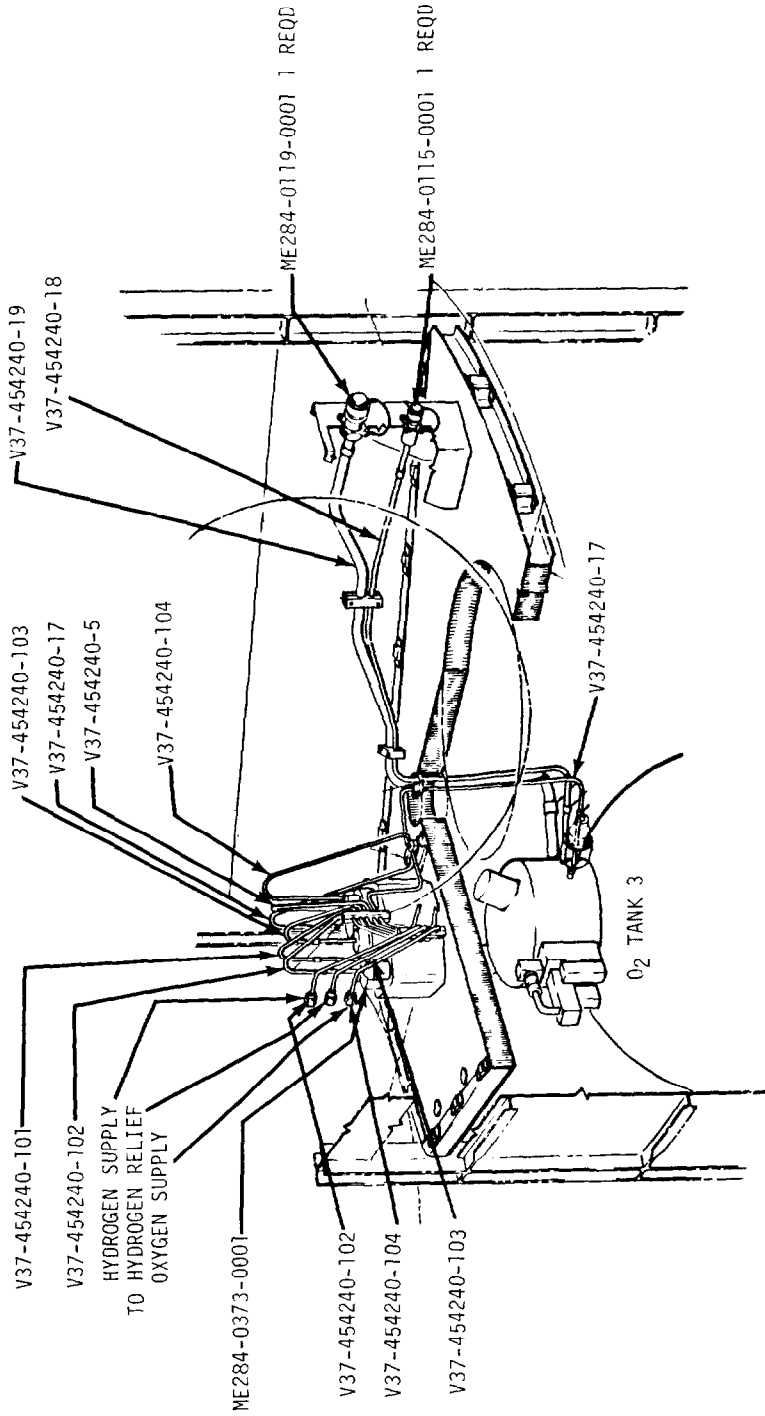

VIEW B-B

HYDROGEN/OXYGEN TANK SHELF SECTION VIEW SECTOR I

EFFECTIVE ON CSM 112-1115

A-187

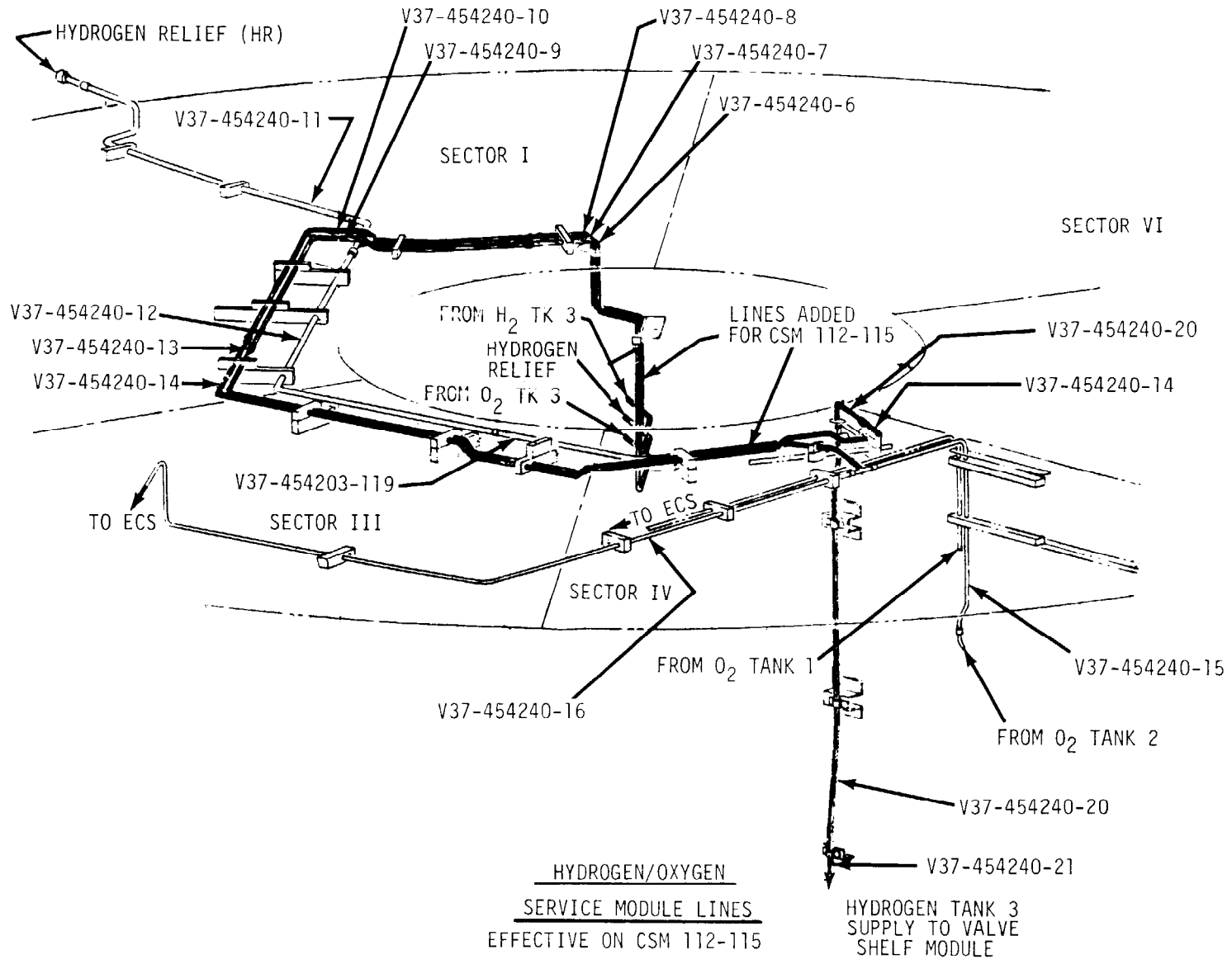

A-188

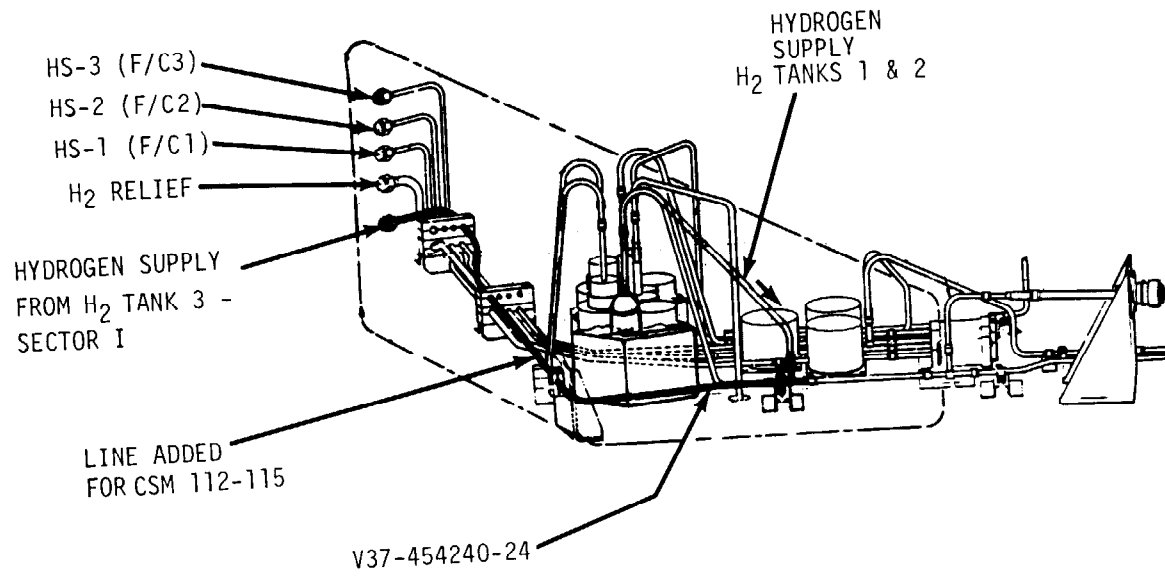

HYDROGEN TANK 3 SUPPLY
INTERFACE WITH TANKS 1 & 2 - HYDROGEN
SHELF VALVE MODULE - SECTOR IV
EFFECTIVE ON CSM 112-115

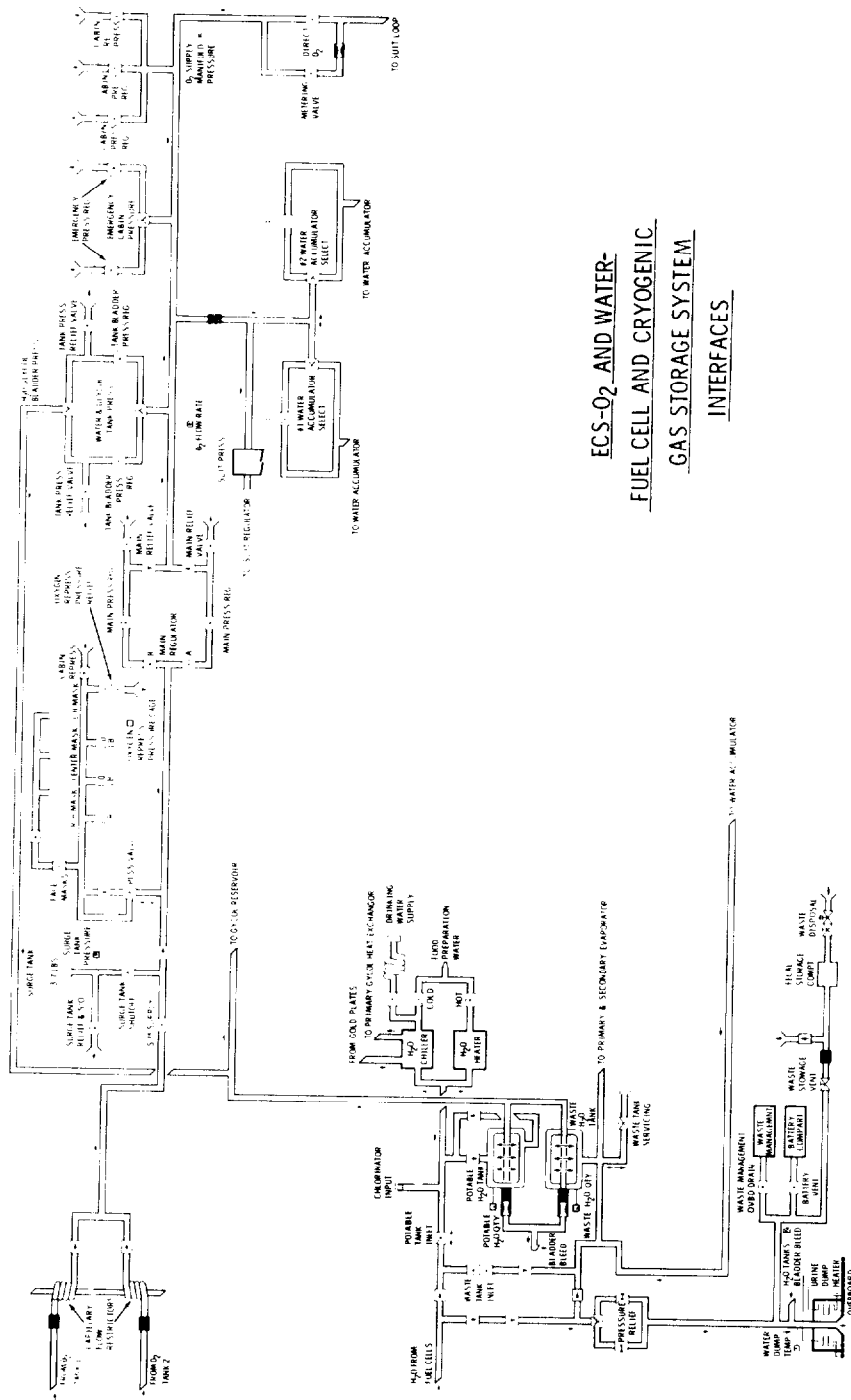

ECS-O₂ AND WATER-
FUEL CELL AND CRYOGENIC
GAS STORAGE SYSTEM
INTERFACES

7.2 FUEL CELL COMPONENT DESCRIPTIONS

FUEL CELL SCHEMATIC

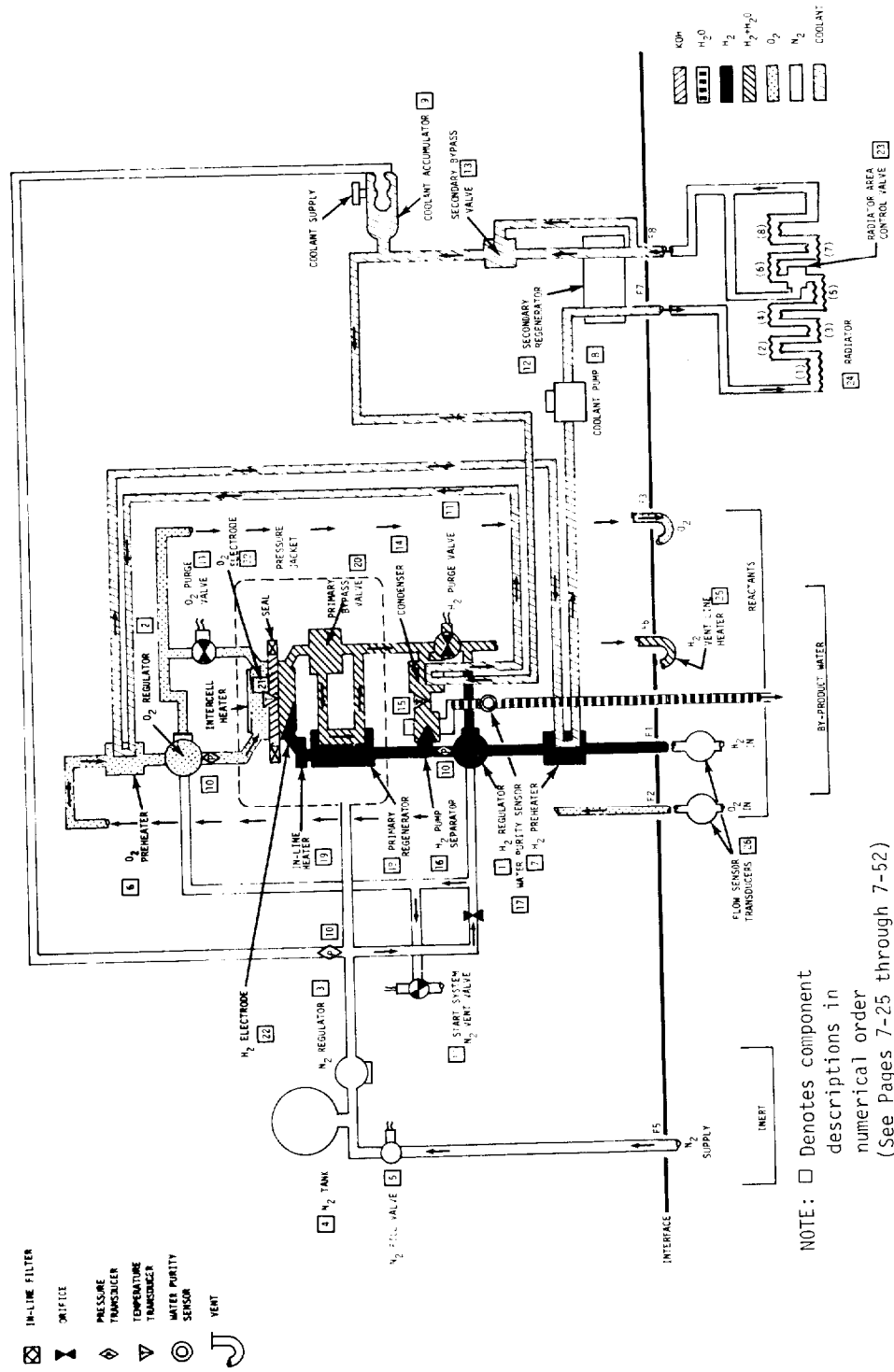

7.3 CRYOGENIC GAS STORAGE SYSTEM
COMPONENT DESCRIPTIONS

A-193

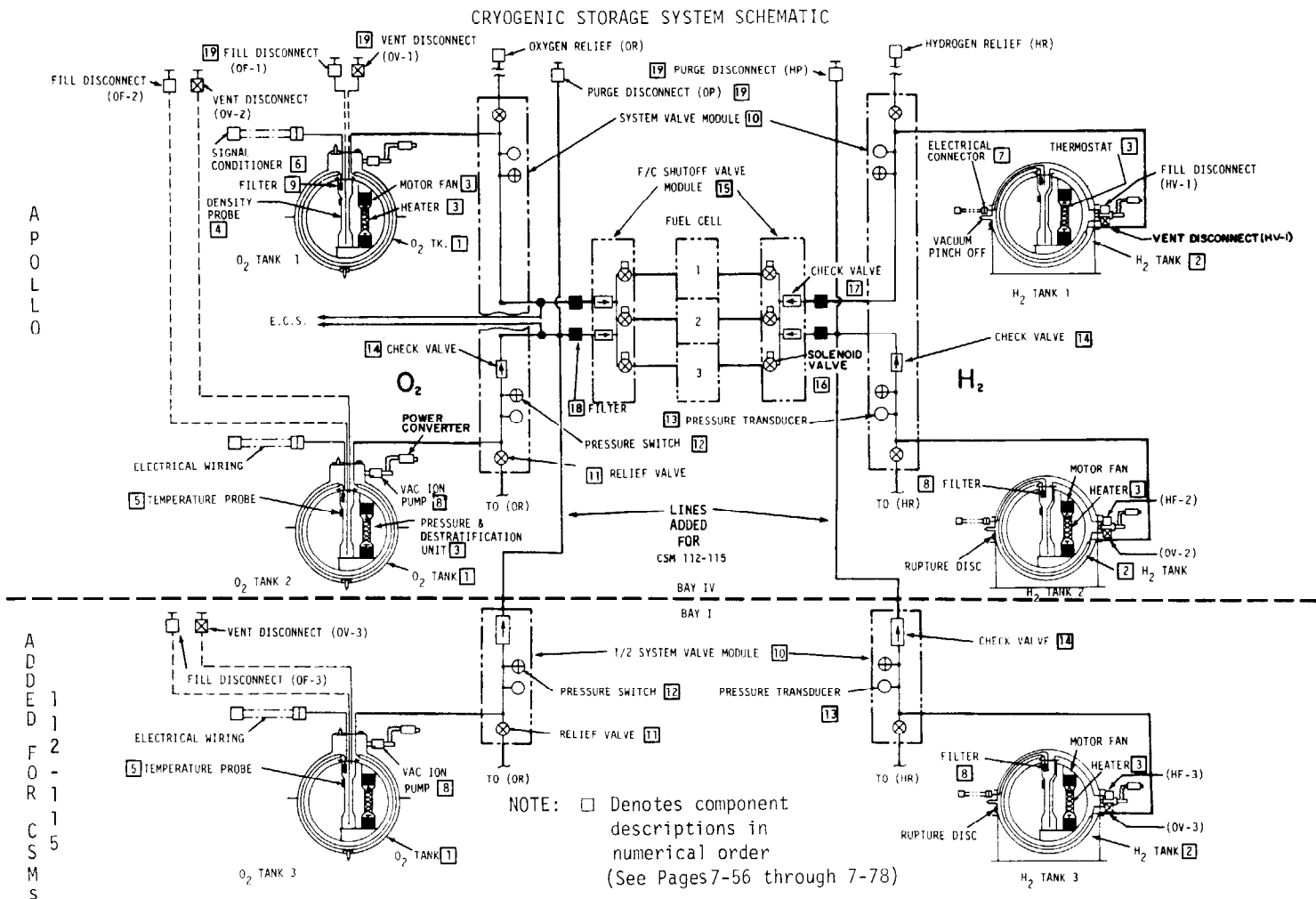

A P O L L O

A
D
D
E
D
1
2
F
O
R
1
1
C
S
M
S
5

TABLE 7.3.1
CRYOGENIC GAS STORAGE SYSTEM INTERFACES

CGSS INTERFACES		
ELECTRICAL INTERFACE		
Valve Modules	Pigtails	Pigtails
Tank Connectors	Hermetically sealed pin receptacle	Hermetically sealed pin receptacle
TANK INTERFACE LINE SIZES		
Fill Connections	1/4" O.D. (0.015 wall)	3/8" O.D. (0.022 wall)
Vent Connections	1/4" O.D. (0.015 wall)	3/4" O.D. (0.028 wall)
Relief Connections	3/16" O.D. (0.022 wall)	3/16" O.D. (0.022 wall)
Feed Connections	1/4" O.D. (0.015 wall)	1/4" O.D. (0.022 wall)
CRYOGENIC VALVE MODULE		
Feed Connections	1/4" O.D. (0.015 wall)	1/4" O.D. (0.022 wall)
F/C Supply Connections	1/4" O.D. (0.022 wall)	1/4" O.D. (0.022 wall)
Relief Valve Outlet	1/4" O.D. (0.022 wall)	1/4" O.D. (0.022 wall)
FUEL CELL VALVE MODULE		
Feed Connections (2)	1/4" O.D. (0.022 wall)	1/4" O.D. (0.022 wall)
F/C Supply Connections (3)	1/4" O.D. (0.022 wall)	1/4" O.D. (0.022 wall)

1 & 2 OXYGEN AND HYDROGEN STORAGE TANK

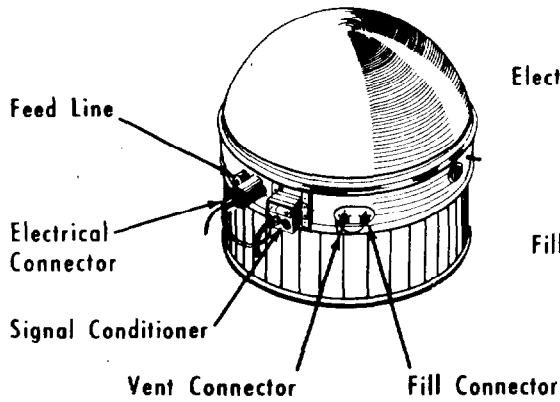

2 H₂ STORAGE TANK

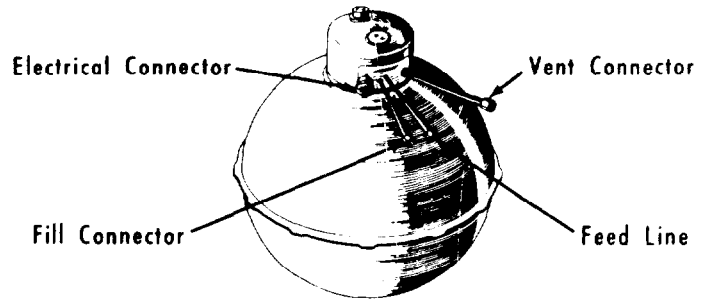

1 O₂ STORAGE TANK

Each storage tank consists of two concentric spherical shells. The annular space between them is evacuated and contains the thermal insulation system, pressure vessel support, fluid lines and the electrical conduit. The inner shell, or pressure vessel is made from forged and machined hemispheres. The pressure vessel support is built up on the pressure vessel from subassemblies and provides features which transmit pressure vessel loads to the support assembly. The fluid lines and the electrical lead line exit the pressure vessel at its top, traverse the annular space and exit the outer shell as follows: O₂, top of tank coil cover; H₂, girth ring equator.

Structural and physical parameters are listed in Tables 7.3.2 and 7.3.3, respectively. Tank volumes, with expansion and contraction data, are listed in Table 7.3.4. Tube sizing is listed in Table 7.3.5.

TABLE 7.3.2 CRYOGENIC TANK STRUCTURAL LIMITS

	<u>Hydrogen</u>	<u>Oxygen</u>
Material	5 Al-2.5 Sn ELI Ti	Inconel 718
Ultimate Strength, psi	105,000	180,000
Yield Strength, psi	95,000	145,000
Young's Modulus, psi	17×10^6	30×10^6
Creep Stress, psi	71,200	No creep at 145,000
Poisson's Ratio	0.30	0.29
Safety Factors -		
Ultimate	1.5	1.5
Yield	1.33	1.33
Creep	1.33	N.A.
Design Stress Level, psi	53,000	110,000
Proof Pressure, psia	400 psia	1357 psia
Burst Pressure, psia	450 psia	1537 psia

TABLE 7.3.3 CRYOGENIC TANK PHYSICAL PARAMETERS

<u>Parameter</u>	<u>Hydrogen</u>	<u>Oxygen</u>
Pressure Vessel		
Material	5A1-2.5 Sn ELI Ti	Inconel 718
Inside Diameter - Inches	28.24	25.06
Wall Thickness - Inches	.044 ± .004 .000	.059 ± .004 .000
Outside Diameter - Inches	28.328	25.178
Outer Shell		
Material	5A1-2.5 Sn ELI Ti	Inconel 750
Inside Diameter - Inches	31.738	26.48
Outside Diameter - Inches	31.804	26.52
Wall Thickness - Inches	.033 ± .002	.020 ± .002
Support		
Flange Diameter - Inches	37.966	28.228
Flange Thickness - Inches	.070 ± .010	.080 ± .010
Bolt Circle Diameter - Inches	32.216	27.50
Number of Bolts	8	12
Annulus		
Annular Space - Inches	1.705"	.653"
Insulation	Vapor-cooled and pas- sive radiation shields.	Vapor-cooled shield with preloaded insulation.
Vacuum Level (TORR) - MM Hg	5 x 10 ⁻⁷	5 x 10 ⁻⁷
Average Pump Down Time	24 Days	24 Days
Burst Disc		
Burst Pressure	90 psi ± 10 20	75 psi ± 7.5
Weight (Empty)		
Spec	75.0 lb.	93.5 lb.
Actual (Maximum)	80.0 lb.	90.8 lb.
Electrical/Instrumentation		
Beech/NAA Interface	Pigtails & Hermetically sealed pin receptacle	Hermetically sealed pin receptacle

TABLE 7.3.4 CRYOGENIC TANK VOLUMES
(With Expansion and Contraction Data)

		INTERNAL VOLUME (Less .02 ft ³ for components)	
		O ₂ Tank	H ₂ Tank
Ambient Pressure	Max. tol.	4.7528 ft ³	6.8314 ft ³
Ambient Temperature	Max. tol.	4.7471 ft ³	6.8045 ft ³
Full Ambient Pressure			
-297 ^o F O ₂	Max. tol.	4.7213 ft ³	6.777 ft ³
-423 ^o F H ₂	Min. tol.	4.7156 ft ³	6.7698 ft ³
Full			
935 psia (O ₂)	Max. tol.	4.7532 ft ³	N/A
-294 ^o F	Min. tol.	4.7497 ft ³	N/A
Full			
865 psia (O ₂)	Max. tol.	4.7508 ft ³	N/A
-294 ^o F	Min. tol.	4.74705 ft ³	N/A
Full			
260 psia (H ₂)	Max. tol.	N/A	6.805 ft ³
-418 ^o F	Min. tol.	N/A	6.80048 ft ³
Full			
225 psia (H ₂)	Max. tol.	N/A	6.8014 ft ³
-418 ^o F	Min. tol.	N/A	6.7963 ft ³
Full			
935 psia (O ₂)	Max. tol.	4.7848 ft ³	N/A
+ 80 ^o F	Min. tol.	4.7812 ft ³	N/A
Full			
260 psia (H ₂)	Max. tol.	N/A	6.8597 ft ³
-200 ^o F	Min. tol.	N/A	6.8550 ft ³

Volumes Used for Tank Calculations

Average Size Cold 835 psia O ₂ 225 psia H ₂	4.74892 Ft ³	6.7988 Ft ³
Average Size Warm 935 psia O ₂ 260 psia H ₂	4.7830 Ft ³	6.8573 Ft ³

TABLE 7.3.5 CRYOGENIC TANK TUBE SIZING

	<u>Hydrogen</u>	<u>Oxygen</u>
Vent Tube	1/4 O.D. x .015 wall 304 L SST	1/2 O.D. x .015 wall (Inside coil cover) 3/4 O.D. x .028 wall (Outside coil cover) Inconel 750 AMS 5582
Fill Tube	1/4 O.D. x .015 wall 304L SST	3/8 O.D. x .022 wall Inconel 750 AMS 5582
Feed Tube*	Common with vent line	1/4 O.D. x .015 wall Inconel 750 AMS 5582
Electrical Tube	1/2 O.D. x .015 wall 304L SST	1/2 O.D. x .015 wall Inconel 750 AMS 5582
Vapor Cooled* Shield Tube	1/4 O.D. x .015 wall 304L SST	3/16 O.D. x .015 wall Inconel 750 AMS 5582
Pressure Vessel to Vapor* Cooled Shield Tube	- - - - -	1/4 O.D. x .015 wall Inconel 750 AMS 5582

* Three tubes joined to provide a single feed line for the oxygen tank only.

3 PRESSURIZATION AND DESTRATIFICATION UNIT

Each of the storage tanks contains a forced convection pressurization and destratification unit. Each unit consists of the following:

- a. A 2.0 inch diameter support tube approximately 3/4 the tank diameter in length.
- b. Two heaters.
- c. Two fan motors.
- d. Two thermostats. Eliminated for H₂ on CSM 113 and on and eliminated for O₂ on CSM 114 and on.

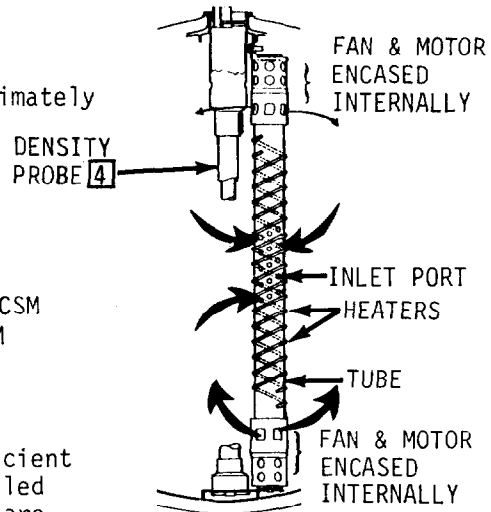

The tube provides a large surface area for efficient heat transfer, and is small enough to be installed through the pressure vessel neck. The heaters are placed along the tube's outer surface and brazed in place. A motor-fan is mounted at the upper and lower ends of the tube, which draw fluid through the inlet ports located along the tube, force it across the heat transfer surface and expel it near the top and bottom of the vessel.

Block II tanks utilize separate sets of lead wires for each heater element and for each motor fan through the electrical connector interface.

FAN MOTORS

The motors are three phase, four wire, 200 volts A.C. line to line, 400 cycles miniature induction type with a centrifugal flow impeller. The minimum impeller speed of the oxygen unit in fluid is 1800 rpm with a torque of 0.90 in. oz., and the hydrogen unit is 3800 rpm with a torque of 0.45 in. oz.. Two fans and motors are used in each vessel.

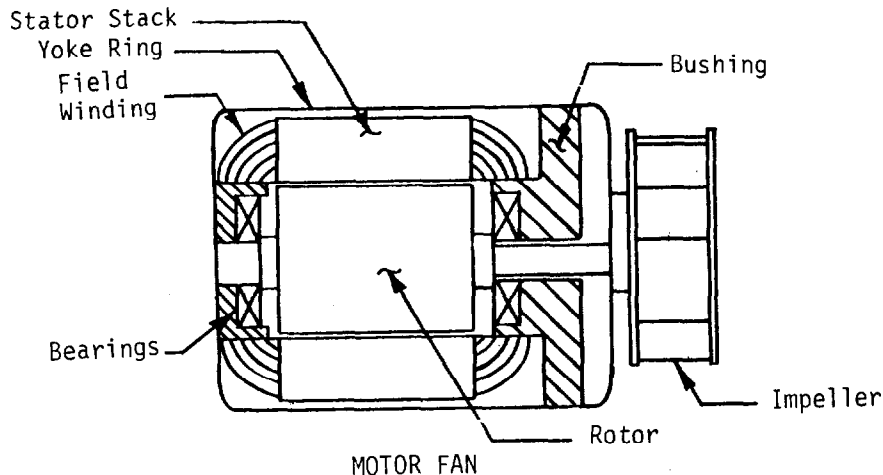

3 PRESSURIZATION AND DESTRATIFICATION UNIT (CONTINUED)

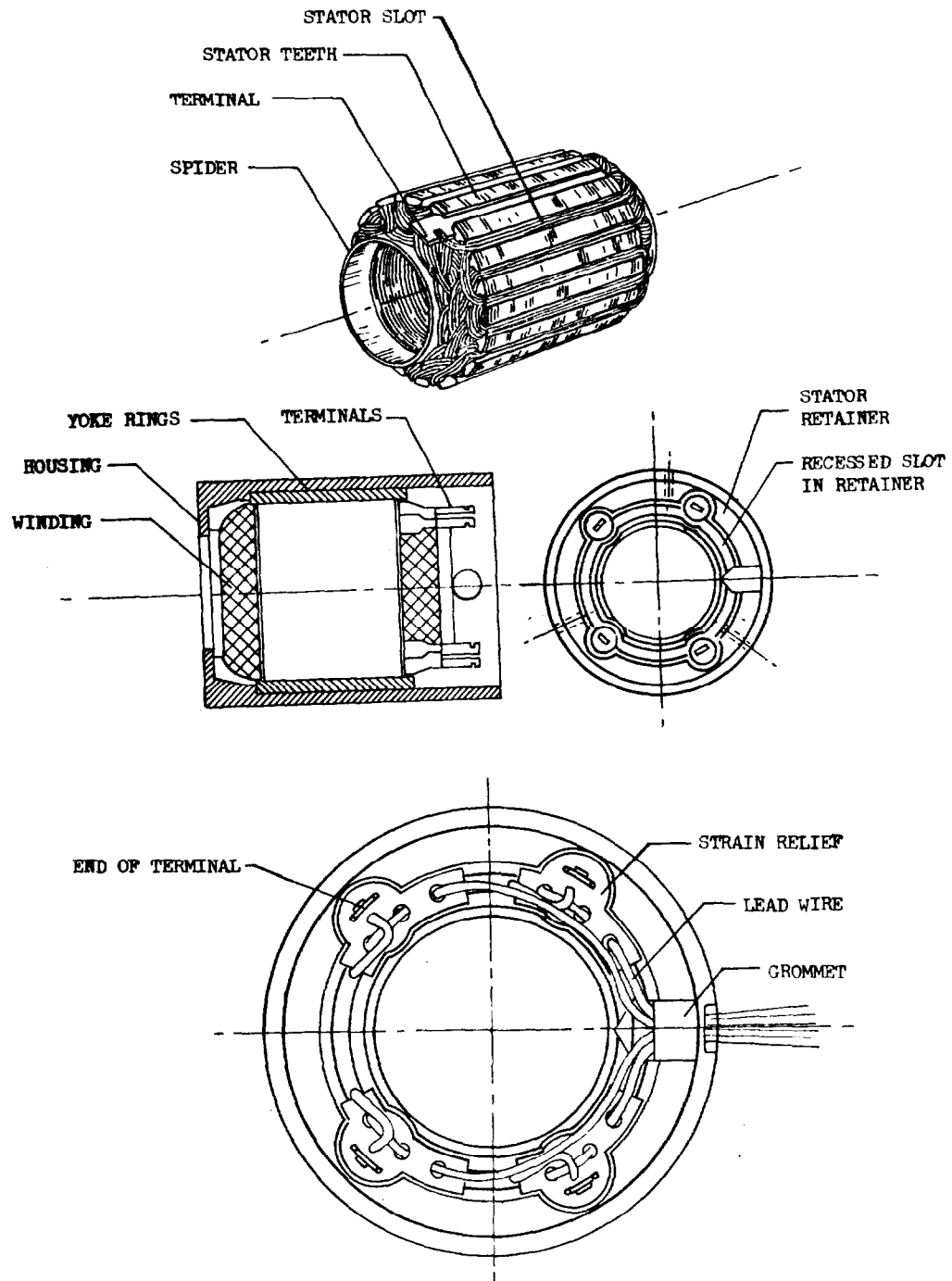

3 PRESSURIZATION AND DESTRATIFICATION UNIT (CONTINUED)

HEATERS

The heaters are a nichrome resistance type, each contained in a thin stainless steel tube insulated with powdered magnesium oxide. The heaters are designed for operation at 28 volts DC during in-flight operation, or 65 volts DC for GSE operation to provide pressurization within the specified time. The heaters are spiralled and brazed along the outer surface of the tube. The heaters are wired in parallel to provide heater redundancy at half power. The heaters have small resistance variation over a temperature range of + 80°F to -420°F.



THERMOSTATS

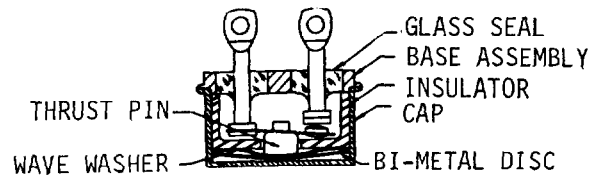

The thermostats are a bimetal type unit developed for cryogenic service. They are in series with the heaters and mounted inside the heater tube with a high conducting mounting bracket arranged so that the terminals protrude through the tube wall. When the heater tube reaches $80 \pm 10^\circ\text{F}$, the thermostats open cutting power to the heaters to prevent over heating of the pressure vessel. When the tube reaches -200°F in the hydrogen tank or -75°F in the oxygen tank the thermostats close allowing power to be supplied to the heaters.

4 DENSITY SENSOR PROBE

The density sensor consists of two concentric tubes which serve as capacitor plates, with the operating media acting as the dielectric between the two. The density of the fluid is directly proportional to the dielectric constant and therefore probe capacitance. The gage is capable of sensing fluid quantity from empty to full during fill and flight operation. The accuracy of the probe is 1.5% of full scale.

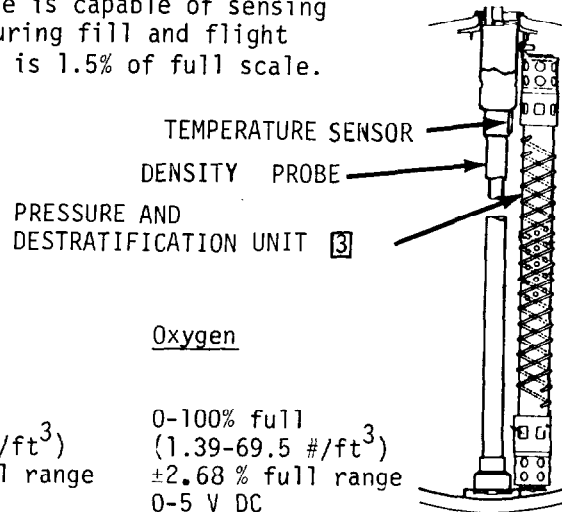

	<u>Hydrogen</u>	<u>Oxygen</u>
Quantity Gaging System		
Range	0-100% full (.17-4.31 #/ft ³)	0-100% full (1.39-69.5 #/ft ³)
Accuracy	±2.68 % full range	±2.68 % full range
Output Voltage	0-5 V DC	0-5 V DC
Output Impedance	500 ohms	500 ohms
Power	2-1/2 watts 115 V 400 cps	2-1/2 watts 115 V 400 cps

5 TEMPERATURE SENSOR

The temperature sensor is a four-wire platinum resistance sensing element mounted on the density sensor (see photograph of density sensor probe). It is a single point sensor encased in a Inconel sheath which only dissipates 1.5 millivolts of power per square inch to minimize self-heating errors. The resistance of the probe is proportional to the fluid temperature and is accurate to within 1.5%.

	<u>Hydrogen</u>	<u>Oxygen</u>
Temperature Gaging System		
Range	-420 ⁰ F to -200 ⁰ F	-320 ⁰ F to +80 ⁰ F
Accuracy	+2.63 % full range	+2.63 % full range
Output Voltage	0-5 VDC	0-5 V DC
Output Impedance	5000 ohms	5000 ohms
Power	1.25 watts 115 V 400 cps	1.25 watts 115 V 400 cps

6 SIGNAL CONDITIONER

The temperature and density amplifiers are separate modules, contained in the same electrical box. The density module functions as an infinite feedback balancing bridge and utilizes solid state circuitry. The temperature module also uses solid state circuits and amplifies the voltage generated across the sensor which is linearly proportional to the resistance of the sensor. The output in both cases is a 0-5 volt DC analog voltage which is fed into the NR interface. The voltage required to run the signal conditioner is 115 V, 300 cycle single phase, and draws a total of 3.75 watts of power. The accuracy of the unit is 1.0% of full scale.

The modules are encased in Emerson-Cumings epoxy potting and the unit is hermetically sealed.

7 ELECTRICAL CONNECTOR

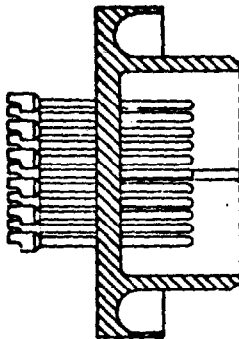

The electrical receptacle is a hermetically sealed device capable of withstanding system pressures and temperature. It contains straight pins with solder cups attached to facilitate the soldering of lead wires from the temperature and density probes, the destratification units and the heaters. The pins are sealed in a ceramic material which has the same coefficient of thermal expansion as the shell and pin material.

8] VAC-ION PUMP

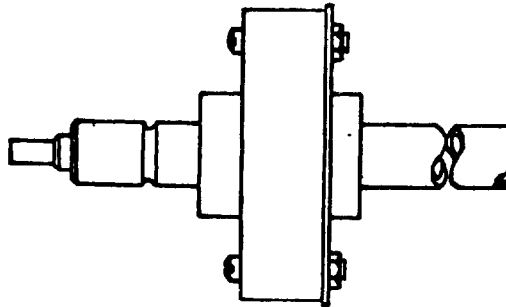

DESCRIPTION

The vac-ion pump is attached directly to the vacuum annulus of the oxygen tank which maintains the insulation space at reduced pressure required for adequate insulation. Pumping action results from bombarding the titanium cathode with ionized gas molecules which become chemically bound to the titanium. The impacting ions sputter titanium from the cathode. The sputtered titanium particles also contribute pumping by gettering action. The pump can be used as a vacuum readout device since the input current to the pump is directly proportional to pressure. The unit is powered by a DC-DC converter capable of putting out the required amounts of power.

CONSTRUCTION

Vac-ion pumps have no moving parts. The pumps consist of two titanium plates spot welded to a vacuum tight stainless steel enclosure with an anode structure mounted between the plates connected to a copper-gold brazed electrical feedthrough. A permanent magnet maintains a magnetic field between the electrodes causing the ions to follow spiral paths thus increasing transit time.

POWER SUPPLY (CONVERTER)

The converter is a solid state device capable of supplying power to the vac-ion pump over a large range of pressure. The unit is energized by a 28 V DC source and is current limited to 350 ma. The unit is capable of putting out 4.2 ma at 10 Volts DC and 1ma at 4000 volts. The unit employs a square wave inverter, a toroid transformer and a quadrupler circuit on the output. Choke filters are supplied on the 28 volt DC input to keep to acceptable limits the amount of conducted interference being fed back from the output. The metal case is well bonded to reduce to acceptable limits radiated interference. The circuits are enclosed in Emerson-Cumings stycastr 2850 Ft.

8 VAC-ION PUMP (CONTINUED)

PERFORMANCE

The pumping rate of the pump is constant at 1 liter per second. Pump current is related to pressure as shown by the graph below.

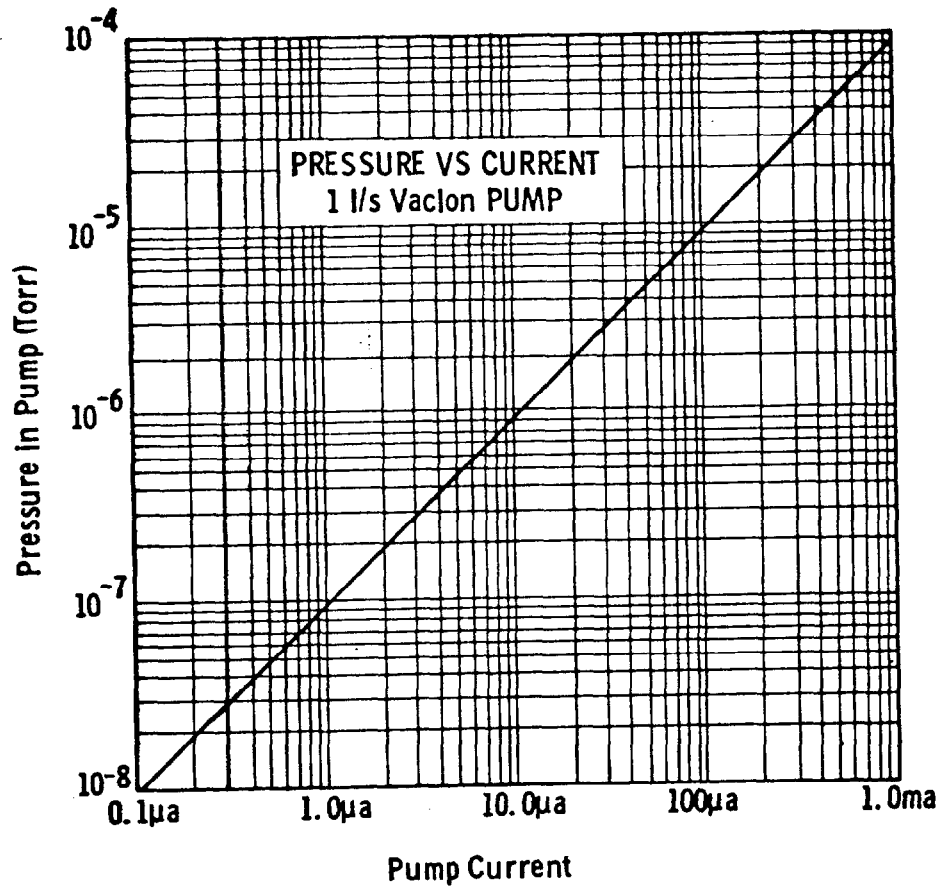

LIFE SPAN

The practical life span of a vac-ion pump while pumping in the various pressure ranges is as follows:

1×10^{-6} region	-	10,000 hours
1×10^{-5} region	-	1,000 hours
1×10^{-4} region	-	100 hours
1×10^{-3} region	-	10 hours

9 FILTER

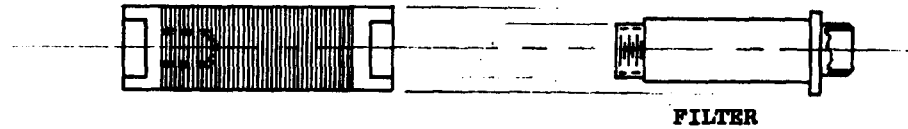

The filter is a multiple disc type element rated at 175 microns absolute. The discs are stacked on a mandrel-like cartridge. The filter is used to trap fibers and particles which could get downstream of the tank and hinder valve module and fuel cell operation. The filter is mounted inside the density probe adapter and is welded onto the feed and vent line.

10 SYSTEM (TANK) VALVE MODULE

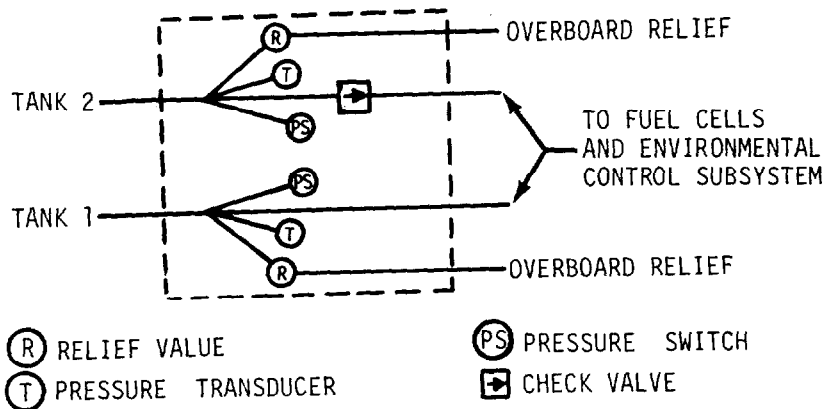
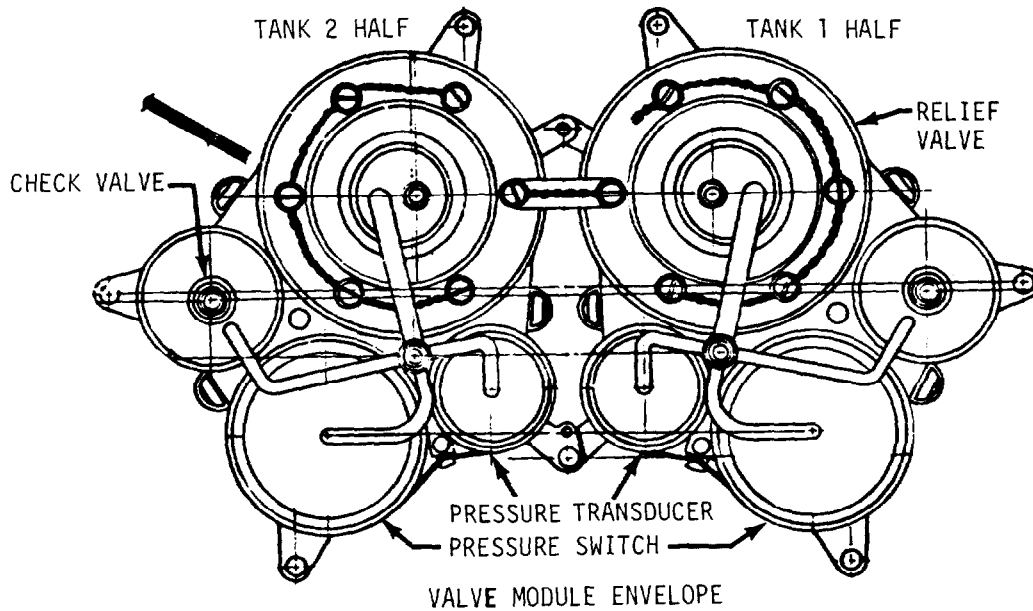

The system (tank) valve module for the hydrogen system and oxygen system are functionally identical. Each module contains two relief valves, two pressure transducers, two pressure switches, and one check valve. These module components are each separately described on the following pages.

11 RELIEF VALVES

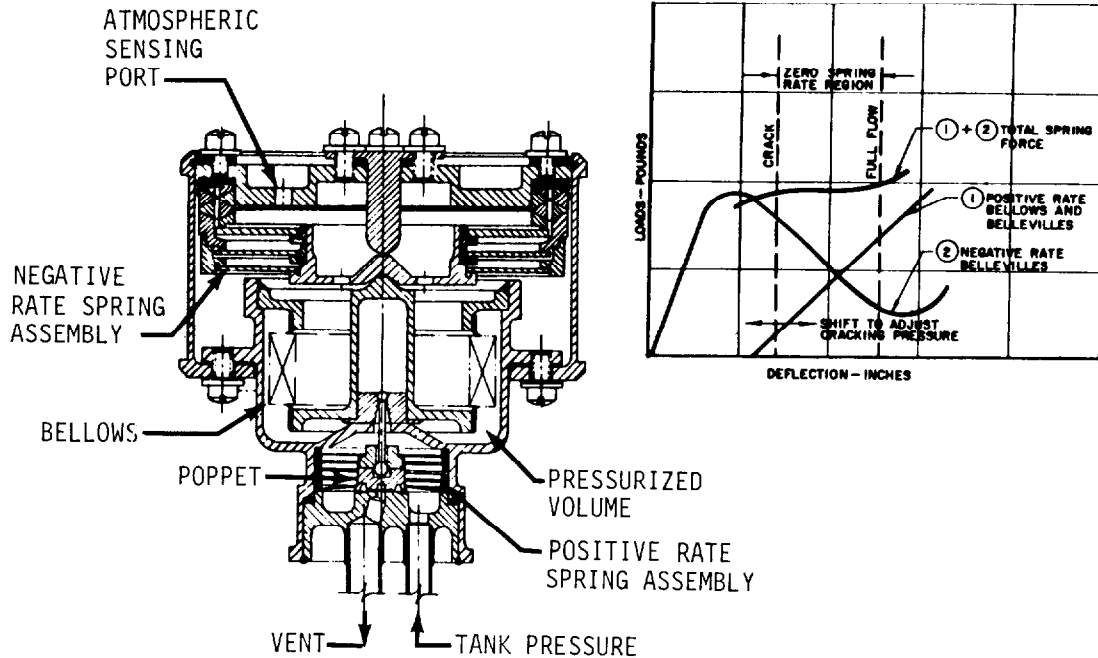

The relief valve, part of the system valve module, is differential type designed to be unaffected by back pressure in the downstream plumbing. The valve has temperature compensation and a self-aligning valve seat. The valve consists of an ambient pressure sensing bellows preloaded with a belleville spring, which operates a poppet valve. Virtually zero pressure increase between crack and full flow is obtained by cancelling out the positive spring rate of the pressure sensing element with a negative-rate belleville spring (see above right). The large sensing element and small valve produces large seat forces with a small crack-to-reseat pressure differential assuring low leakage at the reseat pressure. The Belleville springs are made of 17-4 PH and 17-7 PH stainless steels. The bellows is a three-ply device designed to prevent fractures due to resonant vibrations.

The relief crack pressure is 273 psig minimum for hydrogen tanks and 983 psig minimum for oxygen tanks. The valve is atmospheric sensing; therefore, relief crack pressure in space is 273 psia minimum for hydrogen and 983 psia minimum for oxygen.

	Oxygen	Hydrogen
Full Flow Pressure	1010 psig (max.)	285 psig (max.)
Reseat Pressure	965 psig (min.)	268 psig (min.)

12 PRESSURE SWITCH

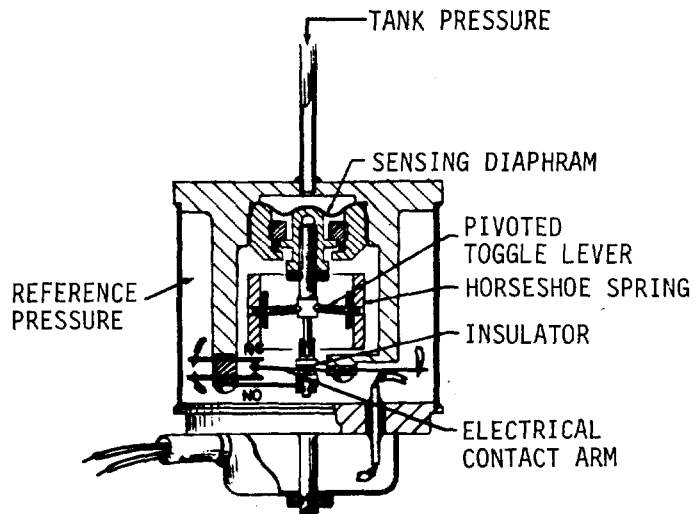

The pressure switch, part of the system valve module, is a double pole, single throw absolute device. A positive reference pressure (less than atmospheric) is used to trim the mechanical trip mechanism to obtain the required absolute switch actuation settings. The reference pressure is typically between 4 to 10 psia. A circular convoluted diaphragm senses tank pressure and actuates a toggle mechanism which provides switching to drive motor switch (Cryogenic Electrical Control Box Assembly). The motor driven switch controls power to both the tank heaters and destratification motors. The pressure switch body is 302 stainless steel and the diaphragm is 17-7 stainless steel. This unit is capable of carrying the current required by the motor driven switch without any degradation. The convoluted diaphragm actuates the switch mechanism in a positive fast manner which eliminates bounce and the resultant voltage transients.

13 CRYOGENIC PRESSURE TRANSDUCER

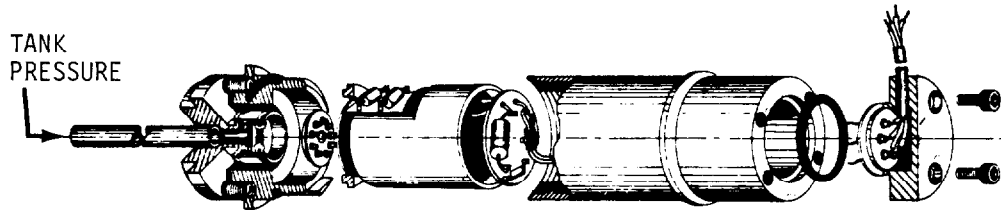

The pressure transducer, part of the system valve module, is an absolute (vacuum reference) device. The transducer consists of a silicon pickup comprised of four sensors mounted on a damped edge diaphragm and an integral signal conditioner. The unit senses tank pressure through the discharge line from the tank. The signal conditioner output is a 0-5 VDC analog output which is linearly proportioned to tank pressure.

	Hydrogen	Oxygen
Range	0 to 350 psia	50 to 1050 psia
Accuracy	± 2.68 % full range	± 2.68 % full range
Output Voltage	0-5 V DC	0-5 V DC
Output Impedance	500 ohms	500 ohms
Power	1.5 watts	1.5 watts
Voltage	28 V DC	28 V DC

14 CHECK VALVE (SYSTEM MODULE)

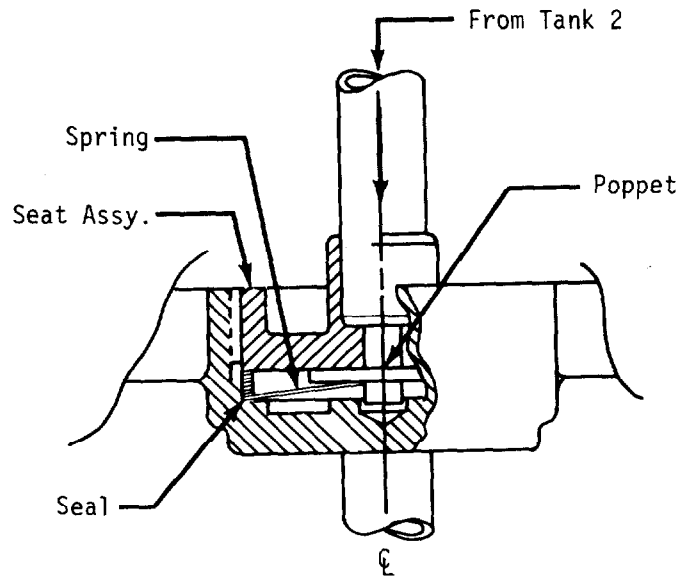

The check valve, part of the system valve module, is designed to open at a differential pressure of approximately 1 psia. The single poppet is spring loaded and has a large area to prevent chattering during flow in the normal direction. This large area also helps in obtaining a positive seal if pressurized in the reverse direction.

15 FUEL CELL VALVE MODULE

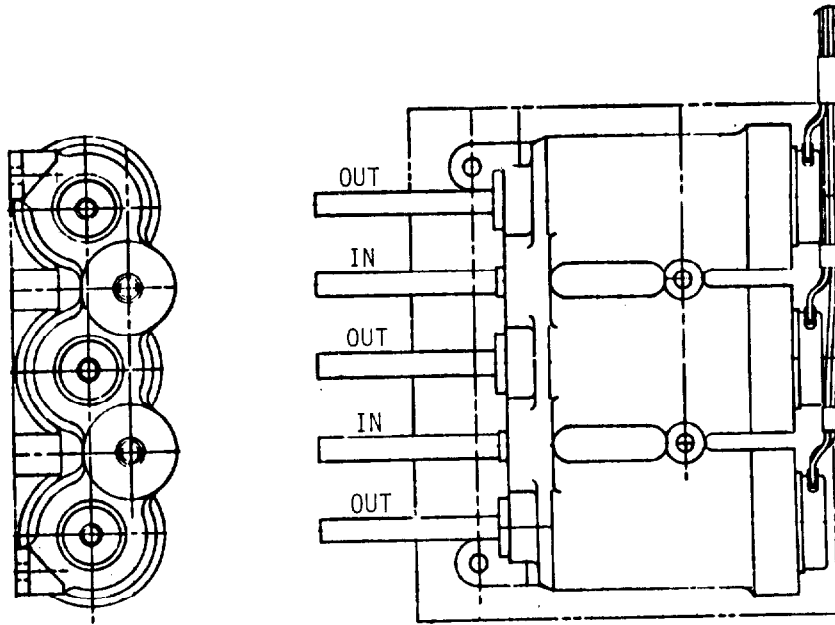

VALVE MODULE ENVELOPE

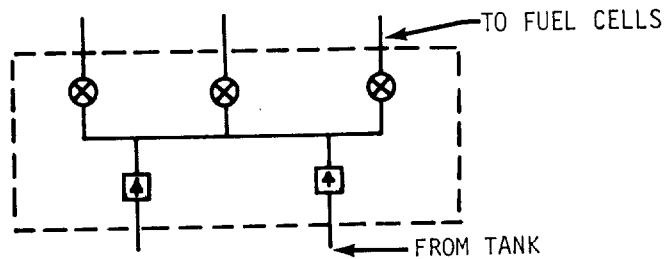

FLOW SCHEMATIC

The fuel cell valve module consists of two check valves and three solenoid shutoff valves contained in a cast body. The separate hydrogen and oxygen modules are functionally identical. Individual valve module components are described on succeeding pages.

16 SOLENOID VALVES

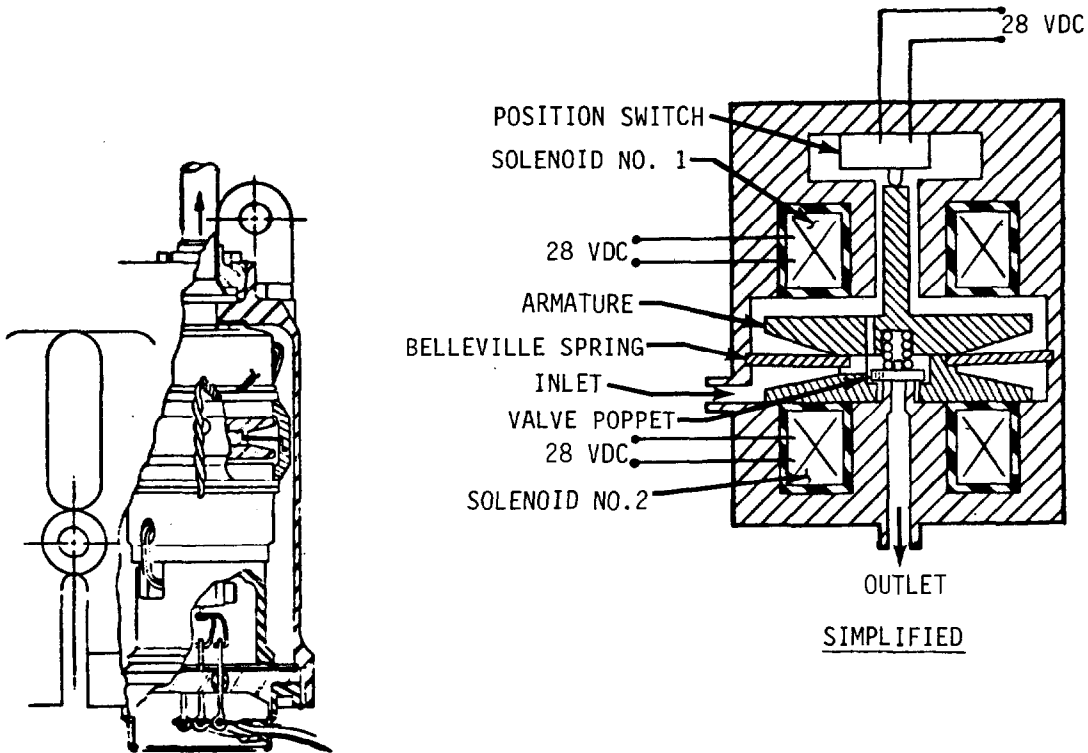

The solenoid valves, part of the fuel cell valve module, employ a poppet-seat arrangement. This poppet is actuated by a magnetic armature which is suspended on a Belleville spring. The upper solenoid is used to open the valve; the lower to close it. The snap-over-center belleville spring both guides the armatures and latches the valve open or closed. A switch to indicate valve closed position is incorporated. The valve opens against pressure and pressure helps seal the valve against leakage in the normal flow direction. The valve body is 321 stainless steel. The maximum in-rush current is 10 amps with steady state current at 2 amps. The solenoid coil circuit has diode noise suppression.

17 CHECK VALVE (FUEL CELL MODULE)

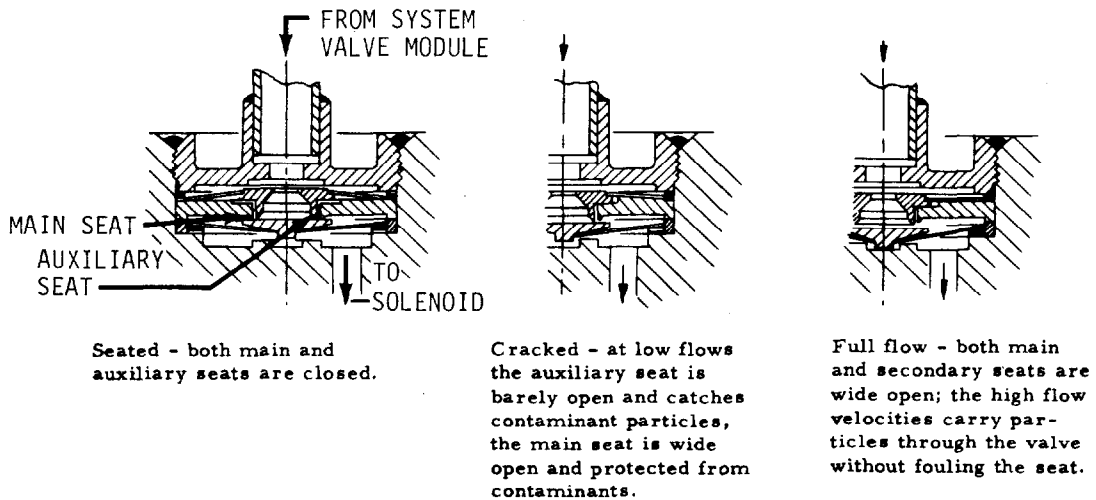

The check valve, part of the fuel cell module, is designed to open at a differential pressure of approximately 1 psia. The valve consists of a main seat and auxiliary seat operating as shown pictorially above. A large seat area provides a positive low leakage seal if pressurized in the reverse direction.

18 H₂-O₂ INLINE FILTER

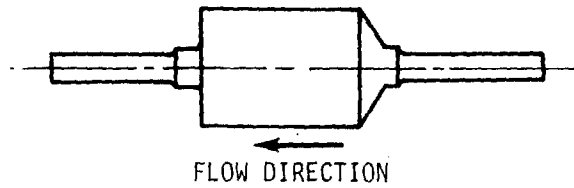

The hydrogen and oxygen reactant filter consists of a multiple of chemically etched discs. The discs are stacked on a mandrel-like cartridge. The filter is used to trap contamination which could get downstream of the reactant tank valve modules. The filter is rated at 5 μ nominal and 12 μ absolute with a dirt holding capacity of .25 grams. The filter design does not allow it to generate system contamination and provides closer adherence to specified filter rating.

19 FILL AND VENT DISCONNECTS - AIRBORNE

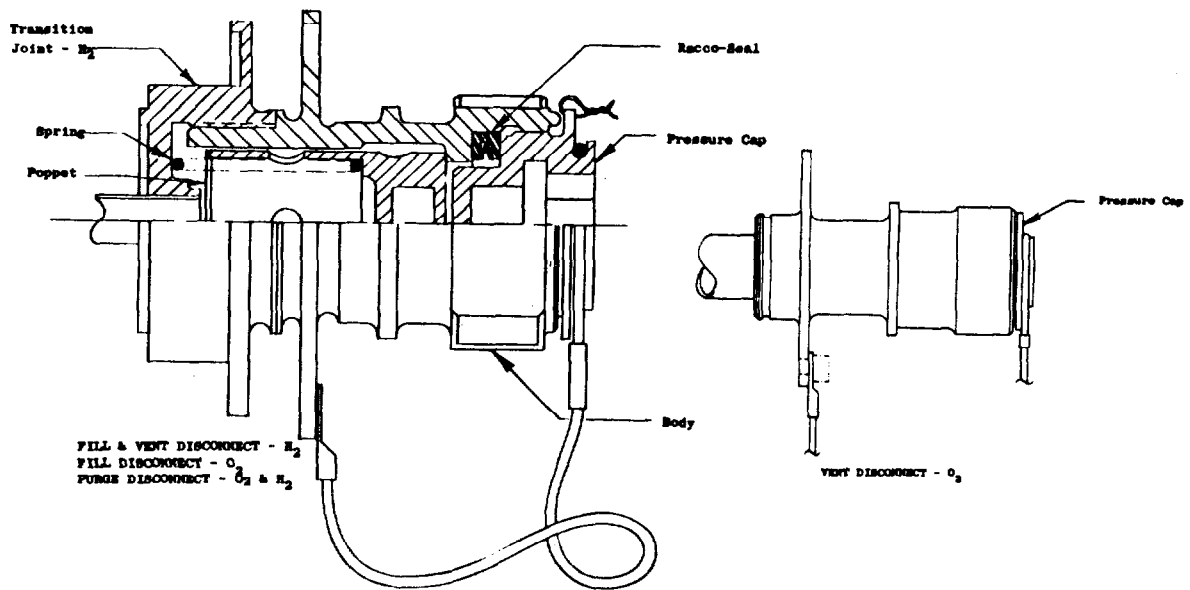

Each vent and fill disconnect utilizes a spring loaded poppet and a pressure cap that can be locked into place. The ground unit is connected by aligning grooves on the ground sleeve with keys on the airborne body, pushing until a stop is reached (about 40 lbs. force is required), and turning the ground sleeve until engagement is complete. The spring loaded poppets can be self opening on installation of mating ground disconnects, or can be opened subsequent to installation of the ground disconnect, depending on the type of ground unit that is used. The poppet is self closing on removal of the ground unit regardless of the type used.

7.4 FUEL CELL/CRYOGENIC
SYSTEM FILTRATION

TABLE 7.4.1
FUEL CELLS/CRYOGENICS - FILTRATION

CRITICAL COMPONENT	MINIMUM CLEARANCE	FILTER PROTECTION		OTHER CHARACTERISTICS
		RATING - SIZE	LOCATION	
Secondary Bypass Valve	0 to 0.006 in. annulus tapered pintle depending on travel	-	No filter	-
Water/Glycol Pump		75 μ nom. 100 μ absolute ₂ Area = 6.6 in ²	Internal to Pump Inlet	Non Bypassing Type
Water Separator Check Valve	Hole Size = 0.030 in. dia Stem Clearance = 0.013 in. Max. Stroke = 0.048 in.	40 μ absolute Area ₂ = 0.076 in. ²	Internal to Water Separator Pump	Made from Sinter Cd Powder
H ₂ Pump		5 μ nom. 12 μ absolute Holding capacity = .25 grams ①	Between H ₂ -O ₂ Valve Module & H ₂ -O ₂ Fuel Cell Module ①	Chem Milled Stacked Disc Filter Element
Primary Bypass Valve	Bi-Metallic Flapper Stroke = 0.040 in. Clearance (min) at full regeneration = 0.013 in.	5 μ nom. 12 μ absolute Holding capacity = .25 grams ①	Between H ₂ -O ₂ Valve Module & H ₂ -O ₂ Fuel Cell Module ①	Chem Milled Stacked Disc Filter Element
H ₂ Regulator	Valve seat clearance open = 0.008 in. Min. radial sliding clearance exposed to gas = 0.006 inches ②	10 μ nom. 25 μ absolute ₂ Area 0.076 in ²	Internal to Regulator Inlet	Made from Sinter Powder

① Filtration also provided by filter at the H₂ Regulator Inlet (see H₂ Regulator)

② Valve open seat clearance is based on regulator flow conditions at 2200 watts plus purge for Apollo 8 regulator.

TABLE 7.4.1
FUEL CELLS/CRYOGENICS - FILTRATION (Continued)

CRITICAL COMPONENT	MINIMUM CLEARANCE	FILTER PROTECTION		OTHER CHARACTERISTICS
		RATING - SIZE	LOCATION	
H ₂ Purge Valve	Ball travel from seat = 0.020 in. to 0.025 in. Min diametric clearance = 0.005 in.	6 μ nom. 18 μ absolute ₂ Area 0.35 in. ²	Internal to Valve Inlet	Cylindrical-Shaped Screen, Bypassing Type
1. H ₂ Purge Valve Orifice (Valve exit)	0.0305 in. dia.	Protective screen (perforated cap) hole size = 0.008 in.	Internal and Upstream of Orifice @ Valve Exit	Lee Jet Size 0.0305 in. orifice, 750 LOHM
O ₂ Regulator	Valve Seat clearance open = 0.005 in. Min. radial sliding clearance exposed to gas = 0.0035 in. \triangleright	10 μ nom. 25 μ absolute Area = 0.076 in. ²	Internal to Regulator Inlet	Made from Sinter Powder
O ₂ Purge Valve	Ball Travel from Seat = 0.020 in. to 0.025 in. Min. diametric clearance = 0.005 in.	6 μ nom. 18 μ absolute ₂ Area = 0.35 in. ²	Internal to Valve Inlet	Cylindrical-Shaped Screen, Bypassing Type
1. O ₂ Purge Valve Orifice (Valve exit)	0.0120 in. dia.	Protective screen (perforated cap) hole size = 0.008 in.	Internal and Upstream of Orifice @ Valve Exit	Lee Jet Size = 0.0120 in. orifice, 4500 LOHM

\triangleright Valve open seat clearance is based on regulator flow conditions at 2200 watts plus purge for Apollo 8 regulator.

TABLE 7.4.1
FUEL CELLS/CRYOGENICS - FILTRATION (Continued)

CRITICAL COMPONENT	MINIMUM CLEARANCE	FILTER PROTECTION		OTHER CHARACTERISTICS
		RATING - SIZE	LOCATION	
N ₂ Vent Valve	Ball seal .020 to .025 inches from seat. Valve pintle travel from sealing seat is .010-.012 in. Maximum diametric clearance .006 inches.	6 μ nom. 18 μ absolute Area = 0.35 in. ²	Internal to Valve Inlet	Cylindrical-Shaped Screen, Bypassing Type
1. N ₂ Vent Valve Orifice	0.0186 in. dia.	Protective screen (perforated cap) hole size = 0.008 in.	Internal and Upstream of Orifice @ Valve Exit	Lee Jet Size = 0.0186 in. orifice, 2000 LOHM
2. N ₂ Vent Valve Vent Port Plug		6 μ nom. 18 μ absolute Area = 0.15 in. ²	Internal to Valve Exit	Cylindrical Screen
N ₂ Fill Valve	Ball seal .020 to .025 inches from seat. Valve pintle travel from sealing seat is .010-.012 in. Minimum diametric clearance .005 inches.			
1. Inlet Port		6 μ nom. 18 μ absolute Area = 0.034 in. ² (Min)	Internal to Valve Inlet	Disc-shaped Screen
2. Interstage		6 μ nom. 18 μ absolute Area = 0.074 in. ² (Min)	Internal to Valve at Interstage and Exit Port	Cylindrical Screen
3. Exit Port				
N ₂ Regulator	Valve Seat Clearance Open, 0.0015 in. Min. radial sliding clearance exposed to gas = 0.0035 in. 	10 μ nom. 25 μ absolute Area 0.076 in. ²	Internal to Regulator Inlet	Made from Sinter Powder



Valve open seat clearance is based on regulator flow conditions at 2200 watts plus purge for Apollo 8 regulator.

TABLE 7.4.1
FUEL CELLS/CRYOGENICS - FILTRATION (Continued)

CRITICAL COMPONENT	MINIMUM CLEARANCE	FILTER PROTECTION		OTHER CHARACTERISTICS
		RATING - SIZE	LOCATION	
N ₂ Regulator Overboard Vent Port Plug		200 MESH screen 0.0018-0.0026 in. dia. wire	Internal to Regulator Exit	Screen Twill or Plain
Metering Orifice	0.0215 in. dia.	Protective screen (per- forated cap) hole size = 0.008 in.	Between N ₂ Regulator ² and O ₂ & H ₂ Regulators	None
Radiator Bypass Valve Main Valve	0.0015 to 0.003 in.	None at Valve Provided by Pump Inlet Filter	Filtration Filter at Coolant Pump Inlet	
Bypass Valve Orifice/Stroke Main Valve	0.002 to 0.004 in. 0.156 in/0.060 in.			
Bypass Valve	0.420 in/0.018 in.			
Valve Module, H ₂ (Consists of 2 relief valves, 2 press. switches, 2 press. transducers, and one check valve)		175μ absolute Area = 0.97 in. ²	Internal to H ₂ Cryogenic Tanks Outlet	Chem Milled Stacked Disc Filter Element
Valve Module, O ₂ (Consists of 2 relief valves, 2 press. switches, 2 press. transducers, and one check valve)		175μ absolute Area = 0.97 in. ²	Internal to O ₂ Cryogenic Tanks Outlet	Chem Milled Stacked Disc Filter Element

A-222

TABLE 7.4.1
 FUEL CELLS/CRYOGENICS - FILTRATION (Continued)

CRITICAL COMPONENT	MINIMUM CLEARANCE	FILTER PROTECTION		OTHER CHARACTERISTICS
		RATING - SIZE	LOCATION	
H ₂ -O ₂ Fuel Cell Valve Module (Consist of 2 check valves and 3 solenoid valves each)		5μ nom. 12μ absolute Holding capacity = .25 grams	Between H ₂ -O ₂ Valve Module and H ₂ -O ₂ Fuel Cell Module	Chem Milled Stacked Disc Filter Element