

ABWR Design and Its Evolution - Primary System Design of ABWR and ABWR-II -

Katsumi Yamada^{1*}, Satoko Tajima¹, Masaaki Tsubaki² and Hideo Soneda³

¹Toshiba Corporation, 8, Shinsugita-cho, Isogo-ku, Yokohama, Kanagawa, 235-8523, Japan

²Hitachi, Ltd., 2-2, Oomika-cho 5-chome, Hitachi, 319-1211, Japan

³Hitachi, Ltd., 1-1, Saiwai-cho 3-chome, Hitachi, 317-8511, Japan

This paper summarizes the primary system design of Advanced Boiling Water Reactor (ABWR) and its evolutionary reactor, ABWR-II. The primary system of ABWR as well as ABWR-II mainly consists of reactor pressure vessel and reactor internals (RPV/RIN) system, reactor recirculation system (RRS), steam separation system, main steam line (MSL) system, and control rod drive (CRD) system. The design of each system is described. It also introduces some of new systems and components developed or under development

In the development of ABWR primary system, extensive tests were conducted to confirm performance and reliability of the design in accordance with the principle of "test before use". More than 20 programs were conducted in Japan by BWR utilities and manufacturers as Joint Study Programs for the tests and development (T&D) of the main components.

In the development of ABWR-II primary system, numerical flow analysis technologies are playing more important roles. Many numerical flow simulations are used to evaluate or even optimize the performances of new systems and components. It is the first step of "design by analysis" for the primary system development.

KEYWORDS: ABWR, ABWR-II, primary system design, component development, design by analysis

I. Introduction

The first ABWR started its commercial operation in 1996, about 20 years after the start of development efforts. The ABWR was developed by integration of the most advanced technologies and operating experiences to improve BWR design in safety, reliability, operability, maintainability and economy¹⁾. The design of the primary system also has been improved remarkably by adopting world's top technologies, such as reactor internal pumps (RIPs) and fine motion control rod drives (FMCRDs).

In 1991, just after the start of construction of the first ABWR, a new program for development of ABWR-II, the next-generation ABWR, was started. ABWR-II is expected to start its commercial operation in the late 2010's. The target of ABWR-II development is to improve and evolve ABWR technologies further to make nuclear power generation more competitive in near future.

The feature of ABWR-II is large electric power output of 1700MWe-class with adoption of large fuel bundles, about 1.5 times larger than the current BWR fuel bundle size.

The primary system design of ABWR-II is being developed now. Some development projects of new systems and components for the primary system have been completed and others are under development. Most of the new components will be also adopted in next ABWRs to improve their performance and economy.

This paper summarizes the primary system design of ABWR and ABWR-II and introduces the R&D activities for developing new systems and components.

II. Description of the primary system

The major functions of the primary system are to deliver the steam generated in the core to the turbine system and to provide the safety functions of preventing overpressure during pressurization transients and isolating the radioactive materials inside the primary containment vessel (PCV) during accident conditions.

The overview of the ABWR primary system is illustrated in **Figure 1**.

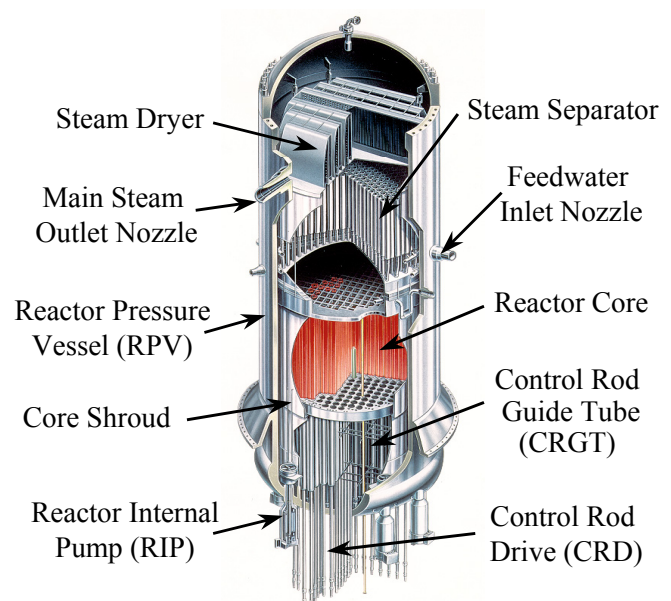

Fig.1 The primary system of ABWR

* Corresponding author, Tel. +81-45-770-2155, Fax. +81-45-770-2179, E-mail: katsumi4.yamada@toshiba.co.jp

Feedwater from the turbine system is injected into the reactor pressure vessel (RPV) through feedwater spargers. The feedwater mixes with the water returning from the separators and the dryers and flows downward through an annular region between the reactor vessel and the core shroud, known as downcomer, forming the recirculation flow.

The driving force for the recirculation flow is provided with recirculation pumps, ten reactor internal pumps (RIPs) mounted in the bottom of the RPV. The pumped-up water flows into the lower plenum and changes the flow direction to upward. The water flows along and outside of the control rod guide tubes (CRGTs) then flows into the core through the inlet orifices, which adjust the flow rate for fuel channels.

The water in the core has functions as moderator and coolant, receiving the heat mainly from fuel rods and vaporizing. At the exit of the core, the coolant forms two-phase flow of about 15% quality.

The mixture of steam and liquid water passes through the standpipes and flows into the steam separators, which separates the water by centrifugal force. The steam with very small droplets goes through the dryer assemblies, which removes most of remaining droplets.

The steam exits from the RPV via four main steam lines to the turbine system. The residual water from the separators and the dryer assemblies flows back into the downcomer.

The control rods control the overall reactor power level. They are vertically inserted into and withdrawn from the core by control rod drive (CRD) mechanisms. The CRDs are bottom entry and mounted on the reactor vessel bottom head. Control rods are inside the CRGTs below the core when they are withdrawn.

The primary system of ABWR as well as ABWR-II mainly consists of reactor pressure vessel and reactor internals (RPV/RIN) system, reactor recirculation system (RRS), steam separation system, main steam line (MSL) system, and control rod drive (CRD) system and excludes the core.

III. Design and Development of Primary System

1. RPV/RIN System

The RPV system is located in the center of the PCV and consists of the main body of RPV and its appurtenances, supports and insulation. It contains the reactor core and acts as a radioactive material barrier during plant operation.

The RPV is a vertical, cylindrical vessel of welded construction with a removable top head. By using large forged rings, the number of welds in the RPV is minimized. The main body of the RPV has a cylindrical shell, flange, bottom head, RIP casings, penetrations, brackets, and nozzles.

The RPV system restrains the CRDs to prevent ejection of the control rod connected with the CRD in the event of a failure of the reactor coolant pressure boundary associated with the CRD housing weld. A restraint system is also provided for each RIP in order to prevent the RIP from

becoming a missile in the event of a failure of the reactor coolant pressure boundary associated with the RIP casing weld.

A reactor vessel support skirt supports the vessel on the reactor pressure vessel pedestal. Anchor bolts extend from the pedestal through the flange of the skirt. RPV stabilizers are provided in the upper portion of the RPV to resist horizontal loads.

The major reactor internal components in the RPV system are core support structures and other reactor internals.

The core support structures include the shroud, shroud support, core plate, top guide, fuel support, and CRGTs. The shroud support is an assembly consisting of a short vertical cylindrical shell, a horizontal annular pump deck plate, forming the partition between the RIP suction and discharge, and vertical support legs.

Other reactor internals are feedwater spargers, shutdown cooling and low pressure core flooders spargers for the residual heat removal system, and high pressure core flooders spargers and couplings.

The plant major specifications and the primary system specifications of ABWR and ABWR-II are summarized in **Table 1**.

The major differences of the RPV/RIN systems which distinguishes ABWR-II from ABWR are:

- The diameter and height of ABWR-II RPV is slightly larger than that of ABWR because of the larger thermal output.
- The number of CRGT is fewer than that of ABWR, in spite of the larger core, due to the adoption of larger-size fuel assembly.
- The cross section of the CRGT in ABWR-II is cruciform instead of circular in ABWR due to the adoption of K-lattice core.

2. Reactor Recirculation System (RRS)

The functions of the RRS are to circulate the required amount of coolant through the core and to control the reactivity by changing the void fraction in the core through the recirculation flow rate.

The main feature of ABWR RRS is to adopt reactor internal pumps (PIRs), which eliminates conventional external loops consisting of the external recirculation pumps, large diameter pipes and internal jet pumps. The adoption of RIPs simplifies the system and contributes the design improvements as follows:

- Enhancement of safety because of no large diameter pipe below the core top level,
- Compact PCV and reactor building,
- Reduction of the power required for the recirculation system,
- Reduction of radiation exposure, and
- Short inspection period with reduction of in-service inspections.

The RIP was first introduced from a European manufacturer and modified and improved in Japan to optimize the pump performance as well as RPV nozzle

configuration²⁾. Extensive tests were conducted to confirm the performance and the reliability.

The principle for utilizing new components in the ABWR was “test before use”. More than 20 programs, including those for RIP, were conducted as Joint Study Programs by the Japanese BWR utilities and three BWR manufacturers for tests and development (T&D). In addition, a comprehensive and full-scale verification test of the RIP system was performed at Nuclear Power Engineering Corporation (NUPEC) funded by the Japanese government.

Ten RIPs, mounted in the bottom of the RPV, provide forced circulation of the reactor coolant through the lower plenum and up through the reactor core, steam separators, and back down the downcomer annulus.

The recirculation flow rate is variable over a “flow window”, from 90% to 111% of the rated flow rate, to control the core reactivity through the void fraction in the core. The RIP rotating speed is controllable by an adjustable speed drive (ASD) for each RIP.

Six ASDs out of ten are supplied power through motor-generator (M-G) sets. The M-G set mitigates the decrease of core flow in case of all RIP trip events and prevents boiling transition of fuel rods, a sudden deterioration in boiling heat transfer caused by the mismatch of heat flux and coolant flow rate resulting in a cladding temperature excursion.

A new type of RIP, which has higher rotating inertia to mitigate the core flow coastdown, has been developed³⁾ and will be adopted for ABWR-II. The purpose of the new RIP is to eliminate the M-G sets.

The structures of conventional and inertia-increased RIPs are compared in **Figure 2**.

To increase the inertia, a flywheel is added around the pump shaft above the motor. The flywheel, increasing in weight and height, requires a larger diameter nozzle with a thicker sleeve.

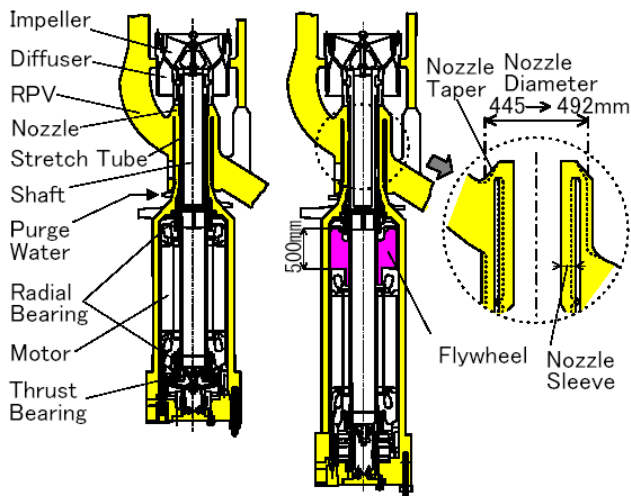

(a) Conventional RIP (b) Inertia-increased RIP
Fig.2 Reactor Internal Pump (RIP) Structures³⁾

The nozzle diameter is optimized through sub-scale pump tests to minimize the increase of pressure loss for the RIP. And the characteristics are verified through full-scale pump tests, which include measurements of the RIP coastdown time, vibration levels of pump casing and rotor, temperature fluctuation of purge water and so on.

The test results have shown good performance of the new RIP. It is concluded that the new RIP can eliminate the M-G sets.

One of the most important technical issues to be clarified for ABWR-II is the effect of flow-induced vibration (FIV) of lower plenum structures. The discharged flow from RIPs, causing pressure fluctuations, vibrates the structures.

For the first ABWR, sub-scale/full-sector and full-scale/partial-sector model tests were conducted. And the strains were measured in plant tests to evaluate the stresses occurred by FIV and to confirm the integrity of the structures.

In ABWR-II, the shape of CRGT cross section is cruciform instead of circular. The dynamic force on CRGT is estimated to be quite different from that of ABWR because of the difference of the flow fields and asymmetry of the structures.

The fluctuating fluid forces are evaluated by combining 1/10-scale tests to obtain the non-dimensional power spectrum density⁴⁾ and three-dimensional numerical simulations to obtain the average flow velocity distribution in the lower plenum. And the stresses are evaluated by vibration analyses⁵⁾.

An example of numerical simulations of lower plenum flow is shown in **Figure 3**.

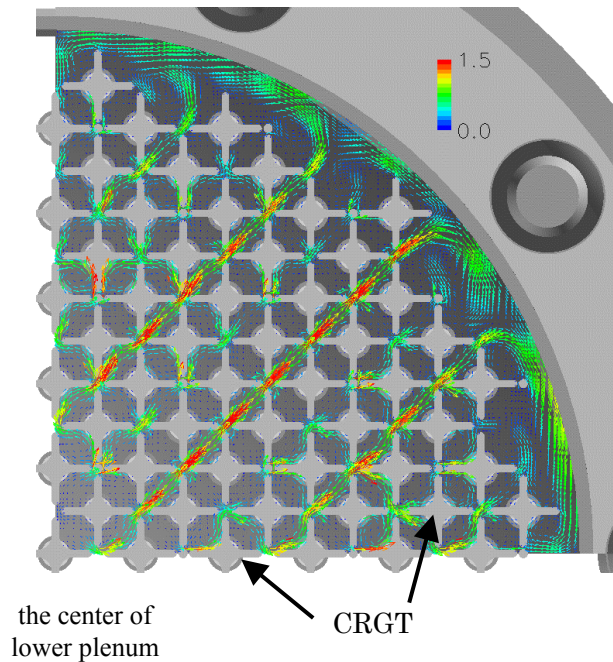

Fig.3 Velocity Distribution at Horizontal Section near the Upper End of Cruciform CRGTs⁵⁾

It is estimated that the maximum stress of ABWR-II CRGTs is less than the fatigue limit.

Researches on FIV are being continued with 1/5-scale/full sector model tests and numerical flow simulations to improve the accuracy of the evaluation method and to evaluate the effect when selected RIPs are tripped.

3. Steam Separation System

The function of the steam separation system is to separate steam from the steam-water mixture and to dry the steam enough to provide the turbine system.

The steam separation system is composed of steam separators and steam dryers. The former separates liquid droplets and steam by centrifugal force and the latter reduces the moisture of the steam through waved vanes. The steam separators are welded at the top of standpipes, which are arrayed on the shroud head, and the steam dryer assemblies are mounted above the steam separators.

A vertical cross sectional view of a steam separator is illustrated in **Figure 4**.

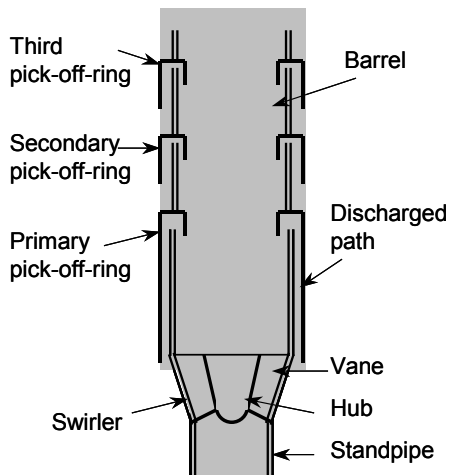

Fig.4 Structure of Steam Separator

A swirler is set at the inlet. The mixture rising through the standpipe impinges on the vanes, which give the mixture a spin and generate swirl flow such that the centrifugal force separates liquid droplets from steam while the mixture flows upward in the three-stage barrel. Steam leaves at the top of the separator and passes into the plenum below the dryers. Water film is gradually formed on the barrel wall and removed by pick-off rings and flows through discharge paths into the pool surrounding the separators.

The steam dryer assemblies are mounted above the steam separators. Steam from the separators flows upwards and outwards through the drying vanes. Moisture is removed with the vanes and drains through troughs into the pool.

Steam separators are a part of recirculation system and cause pressure loss. The reduction of steam separator pressure loss is advantageous because it makes the required pump head lower and the pump power smaller resulting in increase of the plant net electric power output.

An advanced steam separator is under development to reduce the pressure loss by more than 20%, compared with that of conventional one used in ABWR, without changing separation performance⁶.

The swirler geometry is improved with three-dimensional two-phase flow simulations, which has been verified with the comparisons with sub-scale test data. An example of the simulation results is shown in **Figure 5**.

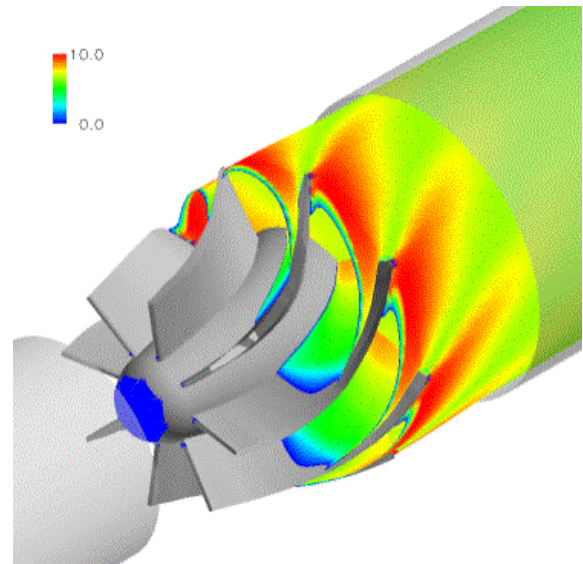

Fig.5 Swirl Flow Distribution in Steam Separator⁶

The behavior of two-phase mixture in the separator is clarified quantitatively. It is found from the pressure distribution in the separator that the inlet and the outlet pressure losses are dominant.

Several design parameters are varied to decrease the pressure loss and to keep the separation performance by analysis. The pressure loss of the improved steam separator is estimated to be more than 30% lower than that of the conventional one.

The verification tests with a full size separator are being planned.

4. Main Steam Line (MSL) System

The main function of the MSL system is to direct steam from the RPV to the turbine system during normal operation. Another important function of MSL system is to prevent overpressure of the primary system during plant transients resulting in high system pressure or during accident conditions and to keep the radioactive materials inside PCV during MSL break accident conditions.

Steam exits from the RPV through four nozzles. The steam flow rate is measured by the venturi-type flow element built in the nozzles of each MSLs. The flow element also has a safety function of limiting the coolant blowdown rate from the RPV when a MSL break would occur.

There are 18 safety/relief valves (SRVs) installed on the MSLs between the RPV and the inboard MSIV in ABWR to

protect against overpressure of the reactor primary system. The valve is designed to actuate as both a safety mode and a relief mode. Each SRV has its discharge line to a quencher in the suppression pool, where the discharged steam is condensed.

The total capacity or the number of SRVs is decided through the analyses of the most severe pressurization transients, such as turbine trip or all MSIV closure. It is designed to limit the peak pressure of the primary pressure boundary component to less than 110% of the design pressure during the transient events.

Eight valves are selected out of eighteen SRVs to be designed to have function of automatic depressurization system (ADS) for small break LOCAs.

Two main steam isolation valves (MSIVs) are welded into each of the four MSLs, one inboard and one outboard of PCV penetration. The MSIV has a safety function of isolating radioactive materials inside PCV during an MSL break accident.

The MSIV is spring-loaded, pneumatic piston-operated, Y-pattern globe valve. The Y-pattern configuration allows a low-pressure loss during normal operation.

In ABWR-II plant the reactor thermal output and the main steam flow rate are increased to 1.3 times larger than in ABWR. The number of SRVs in ABWR-II would be 24 if the conventional valve as in ABWR would be adopted.

A new SRV is being developed to minimize the cost for SRVs and to reduce the maintenance work⁷⁾. The nominal capacity of steam flow rate is increased to about 1.7 times larger than the conventional one. The increase of the capacity reduces the number of SRVs to 14.

The structure is simplified to reduce the maintenance work. The actuator is integrated into the main body below the spring^{7,8)}, as illustrated in **Figure 6**.

In the safety mode operation of the new valve, the main disc is held down by main spring force and opened by inlet steam pressure directly without any external operations. The mechanism is identical to that of the conventional one.

In the relief mode operation of the new valve, the solenoid driven pneumatic actuator integrated into the valve body lifts the stem directly. Whereas, in the conventional valve, the actuator is connected to the spring case and lifts the stem indirectly with a lever.

A new MSIV is under development to increase the capacity of steam mass flow rate and to reduce its pressure loss⁸⁾.

The new type of MSIV for ABWR-II, which is now under development, is illustrated in **Figure 7**, compared with the conventional one. The seat diameter of the new MSIV is increased to be almost the same as the piping diameter. This full-bore MSIV increases its capacity as well as the increase in the nominal size from 28B to 30B corresponding to increase in the thermal output of ABWR-II.

The internal configuration of the valve is optimized to minimize the pressure loss. The pressure loss of the new MSIV in ABWR-II plant is estimated approximately 50% of the current valve in ABWR plant, which would increase the electric output by 1.8MWe.

As for the driving mechanism of the new MSIV, the center of gravity is lowered through relocating the air cylinder and the oil damper and setting aside the external springs, which improves the seismic capability.

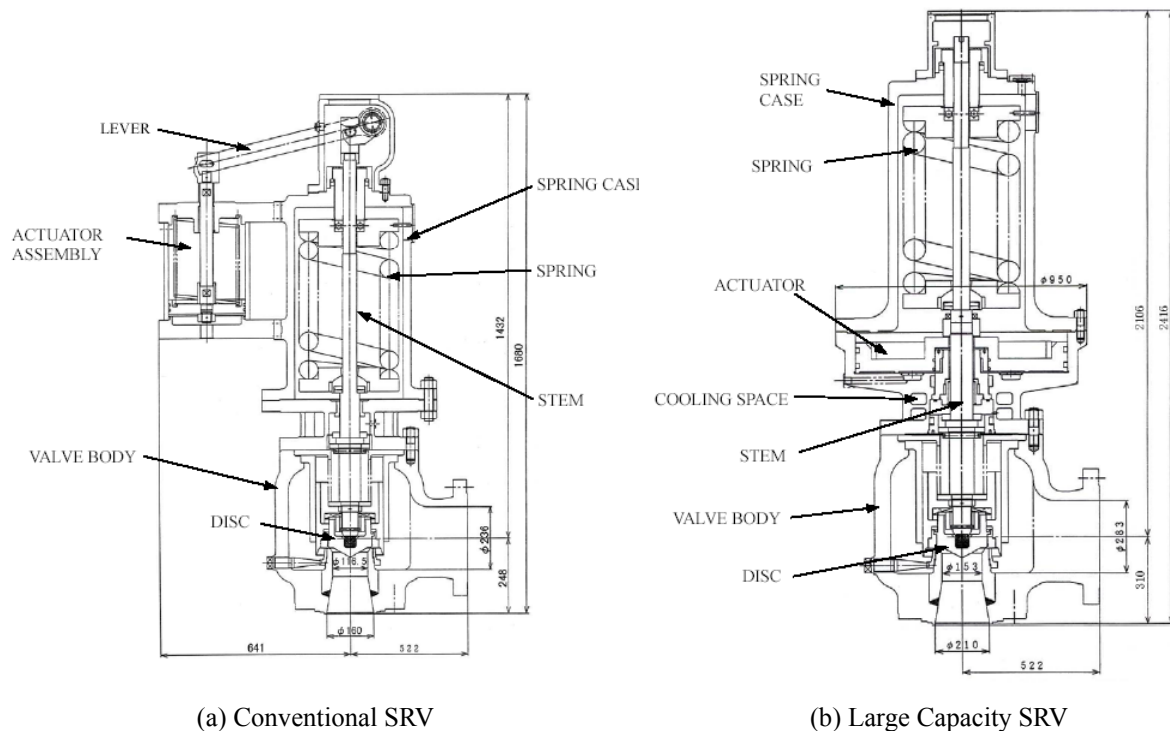
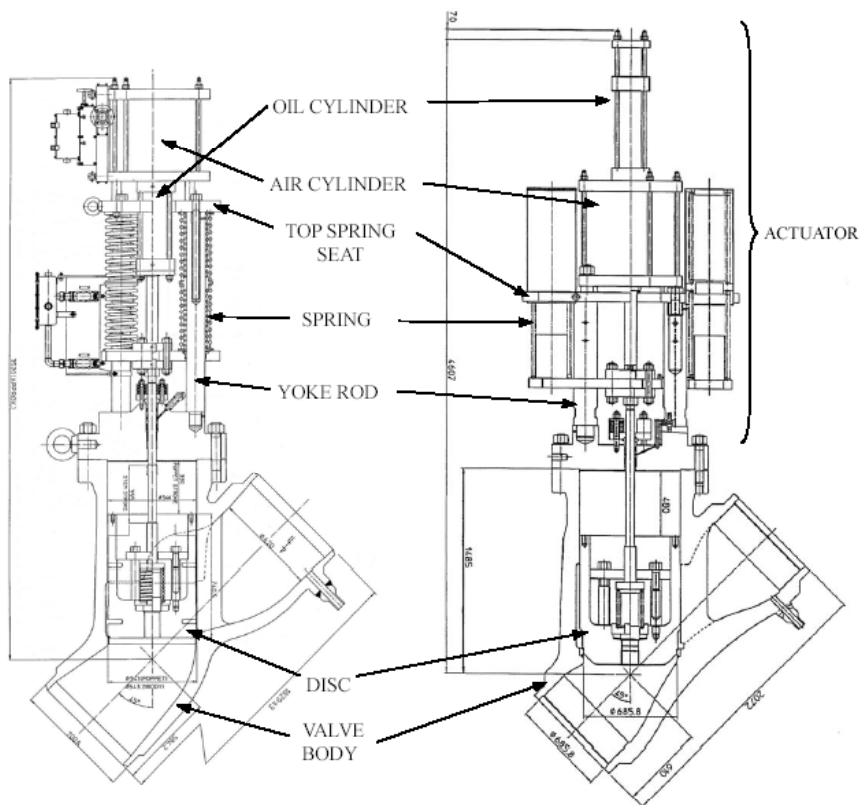

Fig.6 Structures of the conventional and the new SRVs⁸⁾



(a) Conventional MSIV

(b) Large Capacity MSIV

Fig.7 Structures of the conventional and the new MSIVs ⁸⁾

5. Control Rod Drive (CRD) System

The functions of the CRD system are to insert and withdraw the control rod to the designated position to control the core reactivity during normal operation and to insert the control rod rapidly in response to a manual or automatic scram signal.

The CRD system of ABWR is mainly composed of the fine motion control rod drive (FMCRD) mechanisms, the hydraulic control unit (HCU) assemblies and the control rod drive hydraulic subsystem.

The FMCRD is designed to provide electric-motor-driven positioning for normal insertion and withdrawal of the control rod and hydraulic-pressure-driven rapid scram insertion in response to signals from reactor protection system. The electric motor also provides redundant control rod run-in for the hydraulic scram.

The hydraulic pressure is provided through the scram inlet line by pressurized water from HCU accumulator. The control rod drive hydraulic subsystem provides high pressure water to charge the accumulator and purge water flow to FMCRDs during normal operation.

In ABWR there are 205 FMCRDs in housings welded into the RPV bottom. Each FMCRD has a hollow piston tube, which is designed to be movable by a ball nut and a ball screw driven by an electric stepping motor. The upper end of piston is coupled to the bottom of a control rod by a bayonet coupling, which can not decouple without rotation.

There are 103 HCUs, each of which provides sufficient amount of water to insert two FMCRDs rapidly. The pressurized water is provided from a pre-pressurized accumulator.

The water is discharged into the RPV during a scram, which eliminates the scram discharge line and simplifies the system.

The benefits of FMCRD are as follows:

- Fine motion control by the electric motor,
- Shorter startup duration with automatic gang operation,
- Simplified and optimized HCU system,
- Reduction of occupational radiation exposure during its maintenance, and
- High reliability of the coupling between CRD and control rod with separation detection system.

For ABWR-II, the FMCRD has been improved to eliminate the penetration of shaft across the RPV boundary⁹⁾. Driving shafts are separated inside and outside the vessel and the torque between the two shafts is transmitted by magnetic force. This magnetic coupling eliminates the gland packing through the RPV, which requires periodic maintenance and has leakage potential.

In addition, the electric motor of S-FMCRD is an induction motor instead of a stepping motor for the simplification of its electric system.

So the seal-less FMCRD (S-FMCRD) improves reliability, maintainability and economy.

The schematic views of S-FMCRD operation modes are illustrated in **Figure 8**.

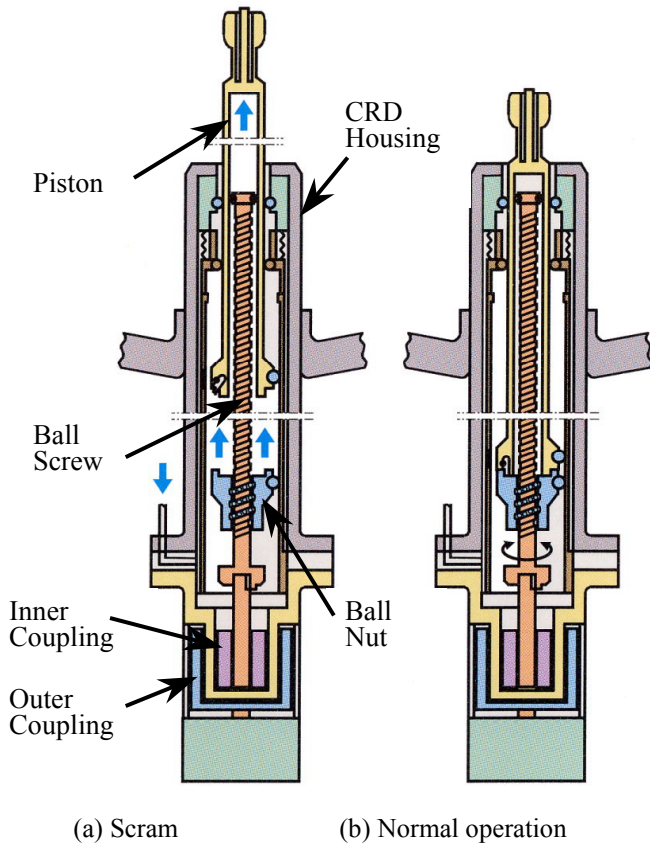

Fig.8 Operation Modes of S-FMCRD

The development of S-FMCRD has been already completed through a Joint Study. They are adopted in Hamaoka Unit 5 of Chubu Electric Power Company, the latest ABWR that is under construction.

IV. Summary

The ABWR was developed by integration of the most advanced technologies and operating experiences. It improves the BWR design in various aspects. For the primary system, the adoption of reactor internal pumps (PIRs) and fine motion control rod drives (FMCRDs) has improved the design remarkably.

The principle of the development of the ABWR primary system component was “test before use”. Extensive tests were conducted to confirm the performance and reliability.

ABWR-II is the evolution of ABWR and expected to start its operation in late 2010’s. New systems and components of the primary system are being developed or under development.

For the development of ABWR-II primary system, numerical flow analysis technologies are playing very important roles to evaluate and/or optimize the performances of new systems and components. It is the first step of

“design by analysis” for the BWR primary system development.

Most of the new systems and components will be adopted not only in ABWR-II but in next ABWRs, continuously improving their reliability, safety, maintainability and economy.

Acknowledgement

Most of the development programs are conducted through the Joint Studies among the Japanese BWR utilities and three plant manufacturers. The utilities are Tokyo Electric Power Company; Tohoku Electric Power Co. Inc.; Chubu Electric Power Co. Inc.; Hokuriku Electric Power Co. Inc.; the Chugoku Electric Power Co. Inc. and the Japan Atomic Power Company. And the manufacturers are General Electric Company; Hitachi, Ltd. and Toshiba Corporation.

The authors wish to acknowledge the utilities for their support and guidance, General Electric Company for their cooperation, and many researchers and engineers in Hitachi, Ltd. and Toshiba Corporation for their efforts.

Abbreviations

- ABWR : Advanced Boiling Water Reactor
- ABWR-II : Advanced Boiling Water Reactor II
- ADS : Automatic Depressurization System
- BWR : Boiling Water Reactor
- CRD : Control Rod Drive
- CRGT : Control Rod Guide Tube
- FIV : Flow Induced Vibration
- FMCRD : Fine Motion Control Rod Drive
- HCU : Hydraulic Control Unit
- LOCA : Loss of Coolant Accident
- M-G : Motor-Generator
- MSIV : Main Steam Isolation Valve
- MSL : Main Steam Line
- PCV : Primary Containment Vessel
- R&D : Research and Development
- RIN : reactor Internals
- RIP : Reactor Internal Pump
- RPV : Reactor Pressure Vessel
- RRS : Reactor Recirculation System
- S-FMCRD : Seal-less Fine Motion Control Rod Drive
- SRV : Safety Relief Valve
- T&D : Tests and Development

References

- 1) R. Ikegami and G. Sato, “The world’s first ABWRs: Kashiwazaki Kariwa-6 and -7”, Nuclear News, December, 2001
- 2) T. Saito, “Technical Achievement of the First ABWR and Its Future”, IAEA Technical Committee Meeting on Improvement in Primary System Components of Current and Future Light Water Reactors, 21-23 May, 1997
- 3) S. Takahashi, K. Umemori, *et al.*, “Development of An Inertia-Increased ABWR Internal Pump”, 10th Int. Conf. on Nuclear Engineering (ICONE-10), Arlington, VA, April 14-18, 2002

- 4) T. Hagiwara, M. Watanabe, *et al.*, "A Measurement of Fluid Forces on Cruciform Cylinders in Cross-Flow", PVP-Vol.420-1, Flow-Induced Vibration-2001 Volume 1, Cross Flow, Heat Exchangers, 2001
- 5) N. Yamashita, S. Kawamura, *et al.*, "Evaluation of Flow-Induced Vibration of Cruciform Control Rod Guide Tubes Using Numerical Flow Analysis", Transactions, SMiRT 16, 2001
- 6) H. Ikeda, T. Shimizu, *et al.*, "Improvement of BWR steam Separator with Three-Dimensional Gas-Liquid Two-Phase Flow Simulation Method", 11th Int. Conf. on Nuclear Engineering (ICONE-11), Tokyo, JAPAN, April 20-23, 2003
- 7) K. Yamada, T. Tokunaga, *et al.*, "A Conceptual Study on Large-Capacity Safety Relief Valve (SRV) for Future BWR Plants", 7th Int. Conf. on Nuclear Engineering (ICONE-7), Tokyo, JAPAN, April 19-23, 1999
- 8) M. Nishimura, G. Itoh, *et al.*, "Development of Large-Capacity Main Steam Isolation Valves and Safety Relief Valves for Next-Generation BWR Plant", Int. Congress on Advanced Nuclear Power Plants (ICAPP), Hollywood, Florida, June 9-13, 2002
- 9) M. Okawada, C. Kojima, *et al.*, "Further Improvement in ABWR (Part 3) Advanced Design of FMCRD System", 7th Int. Conf. on Nuclear Engineering (ICONE-7), Tokyo, JAPAN, April 19-23, 1999
- 10) R. T. Lahey, Jr. and F. J. Moody, "The Thermal-Hydraulics of a Boiling Water Nuclear Reactor", American Nuclear Society, 1977
- 11) IAEA-TECDOC-968, "Status of advanced light water cooled reactor designs 1996", International Atomic Energy Agency, 1997

Table 1 Primary system specifications of ABWR and ABWR-II

Item (Unit)	ABWR ^{*)}	ABWR-II ^{**)}	Comment
Plant Main Specification			
Electrical Output (MWe)	1356	1718	
Thermal Output (MWth)	3926	4960	
Number of Fuel Bundles	872	424 ^{a)}	^{a)} Larger-size bundle
Core Lattice	C-lattice	K-lattice	
Reactor Pressure (MPa)	7.17	7.17	
Feedwater Temp. (deg-C)	216	216	
Main Steam Flow Rate (kg/s)	2122	2682	
RPV/RIN			
RPV Inner Diameter (m)	7.1	7.5	
RPV Inner Height (m)	21.1	21.3	
Number of Control Rods	205	197	
CRGT Cross Section	Circular	Cruciform	
RRS			
Rated Core Flow Rate (kg/s)	14500	15700	
Number of RIPs	10	10	
Steam Separation System			
Number of Steam Separators	349	433 ^{b)}	^{b)} Low pressure loss
Number of Dryer Assemblies	6	7	
MSL System			
Number of Main Steam Lines	4	4	
Number of MSIVs	8	8 ^{c)}	^{c)} Large capacity MSIVs
Number of SRVs	18	14 ^{d)}	^{d)} Large capacity /
Nominal Capacity per SRV (kg/s)	110	189	New structure SRVs
CRD System			
Type of CRD	FMCRD	S-FMCRD ^{e)}	^{e)} Seal-less FMCRD

^{*)} The original design specifications of ABWR

^{**)} The values of ABWR-II specifications are preliminary.