



evropský
sociální
fond v ČR



EVROPSKÁ UNIE



MINISTERSTVO ŠKOLSTVÍ,
MLÁDEŽE A TĚLOVÝCHOVY



OP Vzdělávání
pro konkurenceschopnost

INVESTICE DO ROZVOJE VZDĚLÁVÁNÍ

Vysoká škola báňská – Technická univerzita Ostrava



FORGING

Didactic Text

Miroslav Greger

Ostrava 2014

Description: FORGING
Author: Miroslav Greger

Edition: first, 2014
Pages: 176

Academic materials for the Metallurgy engineering study programme at the Faculty of Metallurgy and Materials Engineering.

Proofreading: none.

Project designation:

Operation Programme of Education towards Competitive Strength

Description: ModIn - Modular innovation of bachelor and subsequent master programmes at the Faculty of Metallurgy and Materials Engineering of VŠB - TU Ostrava

Ref. No.: CZ.1.07/2.2.00/28.0304

Realisation: VŠB – Technical University of Ostrava

© Miroslav Greger

© VŠB – Technical University of Ostrava

Contents

1. Current trends and developments in open die forging of large forged pieces	2
2. Metal forming machines	17
3. Heating in forges	27
4. Heating furnaces and heating in forges	36
5. Level of through-forging and basic forging operations	45
6. Effect of forging procedure on closing imperfections in forgings	63
7. Technological procedures for forging of longitudinal forged pieces	72
8. Drop forging on hammers	84
9. Technological procedure for drop forging	95
10. Drop forging on presses	106
11. Drop forging on horizontal forging machines	114
12. Heat treatment and requirement to properties of forgings	127
13. Defects of forgings	136
14. Consumption of energy in forges	149
15. Die forging perspectives	161

1. Current trends and developments in open die forging of large forged pieces

Chapter contents:

- Production assortment of forges in the Czech Republic
- Forges in the Czech Republic
- Foreign manufacturers and suppliers of open die forgings



Time needed for studying: 90 minutes

Aim: After studying this chapter you will

- Gain a basic idea of assortment of manufactured forgings
- Become acquainted with the forging industry abroad
- Gain an overview of manufacturers of open die forgings in the Czech Republic



Explication

At present the demand for large open die forgings has decreased. New investments for building-up new facilities of large forging shops depend on current orders. The article surveys the state of chosen forging plants both in the world and in the Czech Republic.

The forges for manufacture open die forgings have a wide spectrum of products, in terms of shape and size, materials, and the spectrum of customers. There is a single-part production or short-run production at best. Most forgings are intended for external customers in machined and unmachined states. Only of a small part of forgings, we can say that the interest in them is stable. Sales of the most of them vary during long periods. As a typical example of that fact we can mention forgings for nuclear power plants. 30-40 years ago the capacity of the most of our manufacturers of open die forgings were overloaded by them, and then the interest in them dropped almost to zero, but recently the interest has increased again. Large fluctuations in demand occur also with forgings for shipbuilding industry and with certain other forging groups.

1. General development trends

As for the machinery is concerned only power hammers for smaller forgings were kept and from approximately 1 tonne and more they were replaced by small presses. Moreover, the number of radial forging machines even for large cross-section rods and bars has increased. In the last 10 years 30 forging presses of press power greater than 100 MN at least have been built, which was usually related to expectations of a boom in the field of nuclear energy. Forging manipulators have become commonplace even in the largest forging presses. In the

forges, in the assortment of which rods and bars forged on presses predominate, there are installed two forging manipulators on the only one press. In some forges there oxy-cutting machines were installed for cutting forgings ends or for their possible dividing.

As regards the starting material in smaller forgings manufacture of semi-finished casting products have broken through. Today it is possible to make semi-finished casting products up to their diameter of 800 mm, which can replace even rather large ingots. It has become commonplace to insulate even more better ingots heads, which makes it possible to work with less waste. And the electroslag remelting of ingots, mainly from tool steel has spread. And the proportion of special steels and alloys has increased too.

The assortment of forgings is largely unchanged. However, the proportion of smooth forged roll and square bars and even bars and rods of large cross sections has increased. Requirements on quality and on the extent of testing have increased in the long-term, as well. Demands on quality are mainly related to the branches for which the forgings are destined. The unpleasant fact is that in many cases it is necessary to change over to some larger types which require larger sizes of forgings, which make achieving the necessary quality parameters more difficult. The forges manufactured open die forgings have some fields with guaranteed sales of these forgings. In the first place there is today the power engineering that can be classified into thermal power plants, nuclear power plants and wind-power plants. For thermal power plants there are manufactured primarily shafts for turbines and generators. It is a number of sizes, and it is required not only a high purity of steel but also mechanical properties reachable with difficulties for reasons of very large diameters of these shafts. However, the interest in these forgings is quite stable. For nuclear power engineering there is manufactured a wide range of forgings. The challenging forgings include forged pieces with sockets, shaped bottoms, tube plates, parts of piping, and others. The interest in forgings in this branch is very changeable. For wind-power plants there are forged namely shafts and rings (Fig. 1).



Fig.1 The forging for wind-power plant

2. Development of free forges abroad

For forging of the largest forged pieces, e.g. for a pressure vessel of the EPR reactors AP1000 the required press power is 150 MN and an ingot weight 350 t, at least. In these days some suitable capacities for forging heavy forged pieces can be found out in Japan (Japan Steel Works), in China (China First Heavy Industries and China Erzhong) in the South Korea (Doosan), in France (Le Creusot), in Russia (OMZ Izhora.), and partly also in the Czech Republic (Pilsen steel, Vítkovice Heavy Machinery). New premises are planned in

the Great Britain (Sheffield Forgemasters), in India (Larsen & Toubro, Bharat Forge Ltd.). The overview of the producers of large forged pieces is given in the Table 1.

Table 1. The overview of big manufacturers of open die forgings, forging presses and max. weights of forged ingots

Country, region	Company	Forging presses[MN] till 2010	Forging presses[MN] after 2013	Max. ingot weight [t] (2013)
Japan	Japan Steel Works	140	140 x 2	600 (650)
	JCFC		130	500
South Korea	Doosan	130	170	540
China	CFHI	150; 125	the same	600
	Harbin Boiler	80	the same	-
	Shanghai (SEC)	120	165	600
	China Erzhong + Dongfang	127; 160	the same	600
India	L&T	90	150	600 (in the year 2011)
	BHEL		100	-
	Bharat Forge		140	-
Europe	Areva, SFARsteel	113	the same	250
	Sheffield	100	150?	500 ?
	Pilsen Steel	102	120	200 (250)
	VITKOVICE	120	the same	250
	Saarschmiede	86.7	the same	200
Russia	OMZ Izhora	120	150	600
The U.S.A.	Lehigh	100	the same	270

2.1 Japan Steel Works (JSW)

The biggest and most famous supplier of heavy forgings is the Japan Steel Works (JSW). They produce large forgings for reactor pressure vessels, steam generators, turbine shafts, ship drive shafts, and they supply 80% of the world market by large forged parts for nuclear power plants. The JSW operate hydraulic forging presses from 30 to MN 140 MN in their plant in Muroran, and they also supply steel ingots up to 600-ton made in their own steel plant (Fig. 1). In the year 2010 they put into operation the second forging press of 140 MN. The forge supplies other components for nuclear power plants and shipbuilding industry: pressurizers, generators and turbine rotors, crankshafts, piping for primary circuits of nuclear power plants and steel rolls (Fig. 3) and other large forgings. At the present time for forgings of large rolls for work in cold state there are increasingly used steels of higher strength as e.g. 5% Cr-Mo steel which hardness is about 70 HRC, which increases their wear resistance [1].

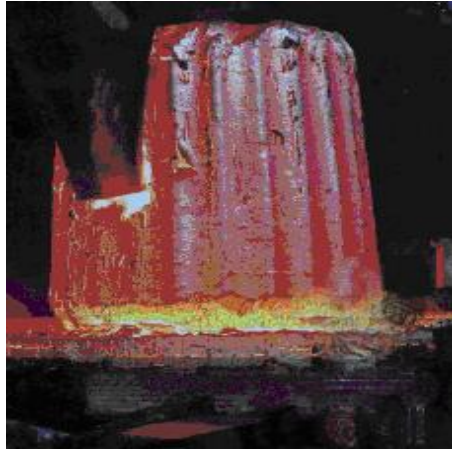

Fig. 2 Ingot of weight 600 t



Fig. 3 Machined forging of a roll of steel 5% Cr –Mo

The steel is melted and refined in a 120-ton electric arc furnace, the content of gases and impurities can be reduced by ladle refining and then it is cast in vacuum. Maximum ingot weight is 600 t, it is the heaviest in the world. For the treatment of high alloy steels and alloys there is used electroslag remelting (ESR) to 100t. After heating to the upper forging temperature the ingots are forged on a selected hydraulic press. The forge disposes of presses 30 MN, 80MN and of two presses 140 MN.

After finish forging a preliminary heat treatment is performed. The aim of the heat treatment after the roughing is to obtain the desired mechanical properties and a fine structure of the forging.

2.2 Japan Casting & Forging Corporation (JCFC)

Together with the Kobe Steel they have expanded on the market with heavy forgings. The JCFC operated the press of 80 MN and in the year 2010 they put into operation the forging press of 130 MN and they are able to handle even 500-ton ingots. For the oil industry the Kobe Steel company supplies forged pressure vessels composed up to weight of 2,000 t. Their diameters may be up to 6.8 m and the wall thickness up to 450 mm [6]. They participate significantly in the global market of large marine crankshafts (Fig. 4). The products of the Kobe Steel and the JCFC have acquired an excellent reputation in the international markets. Besides the crankshafts for seagoing ships they supply cardan shafts, rotors and blades of

turbines for the power industry and they also manufacture a wide assortment of metallic moulds for plastic.



Fig.4 The forging of a ship crankshaft forged by the TR method

2.3 Doosan Heavy Industries

They are currently increasing their capacities making essential investments in casting and free forging. In the year 2010 they installed a forging press of 170 MN. In the plant Changwon there is a press of 130 MN used for open die forging. For the Westinghouse they supply pressure vessels for a reactor and steam generators [2]. The Doosan Company has concluded an agreement with the China National Nuclear Corporation (CNNC) on deliveries of heavy forgings and equipment for other projects in China, for Nuclear Power Plant of 1000 MWe. In the year 2009 they purchased the Czech ŠKODA POWER.

2.4 Heavy Industries (CFHI)

In the year 2006 they installed a hydraulic press of 150 MN, at that time the largest in the world. For open die forging they also use a press of 125 MN. In June 2009 they casted and forged ingot of 580 t. Nowadays they can double their production of liquid steel and expand the annual capacity of the forge for open die forging to 240 thousand tons.

2.5 Electric Group Heavy Industries Corporation (SEC)

The Company was founded as early as in the year 1925. Since the year 2008 they have supplied pressure vessels, steam generators and other parts for the PWRs. In the year 2005 a press of 125 MN and also a forging press of 165 MN were operated in the forge. At present there are forged some parts for steam generators as well as parts for NPP made of ingots with the weight up to 600 t. The steel plant has got its capacity of about 500 thousand tons of steel /year and so it is able to supply at real time up to 700 t of molten steel, to cast ingots of weights 600 t, 500 t, and to forge ingots up to weight of 400 t. The forge capacity is 240 thousand tons/year.

For steel melting there are used electric furnaces of 160t/130t/40t. For ladle refining there are used ladle (refining) furnaces of 100t/80t/40t and vacuum die casting of ingots is carried out in the boxes of 600t/350t/250t/150t/60t.

In the forge there are installed hydraulic presses: 150 MN, 100 MN, 60 MN, they are operated by the manipulators of 630 tm, 400 tm and 200 tm.

2.6 China National Erzhong Group Co Ltd

They started the production in the year 1971 and they have become the largest base of heavy engineering in China. The CNEG can produce 600-ton ingots and for forging there is used a hydraulic press of 127 MN. In the year 2009 a new hydraulic press of 160 MN was installed in the forge. As for products the forge is focused on 1,100 MW low-speed generator rotors for the Dongfang Electric. In the year 2010 there was installed a press of 80 MN for drop forging of parts for the aircraft industry.

2.7 Shandong Nuclear Power Equipment Manufacturing Co Ltd (SNPEMC)

The Company was established in the year 2009. For forging, there is used a press of 80 MN. The parent company, the Harbin Power Equipment Co Ltd (HPEC), delivers steam turbines and generators of 1,200 MWe [3].

2.8 Larsen & Toubro Ltd.

It is the biggest engineering and building company in India. They supply reactor pressure vessels for the PHWR reactors and parts of power breed reactors and steam generators. The forge is equipped by a press of 90 MN. There is a project ready for building-up a press of 150MN for manufacture of ultra-large forgings. They can deliver equipment, steam generators, the individual forgings for pressure vessels (Fig.5), primary piping, control systems and they can also provide services for almost all PHWR reactors both in India and abroad



a)



b)

Fig. 5 Ring forging (a) and ring forged piece (b)

2.9 Bharat Heavy Electricals (BHEL) a Bharat Forge Ltd (BFL)

It is a supranational company and it counts among the biggest and technologically most advanced producers of forged and machined parts, namely for the automotive industry. At present they are expanding to the power-producing sector. They will deliver components for nuclear power plants with the power outputs of 700 MWe, 1000 MWe and 1600 MWe, and they are planning installation of a forging press of 100 MN (Fig. 6).

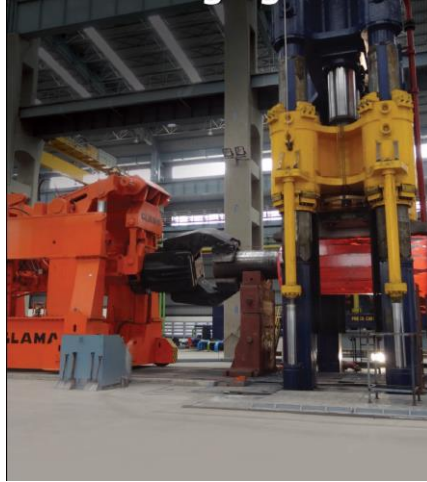

Fig. 6 Forging on the press of 100 MN

2.10 Areva a Areva Creusot Forge

In the year 2006 they acquired the French SFARsteel, one of the world's leading producers of large forged parts (Fig. 7). In Europe they enjoy a very good geographical strategic location for manufacture of very heavy components weighing up to 360 t, and further pressure vessels for reactors, as well as steam generators. They utilize a forging press of 113 MN and a press of 75 MN. The Areva Creusot Forge is a subsidiary company in Burgundy. They specialize in large forgings. And recently they have invested in order to increase their production of heavy components for nuclear power engineering, including big pressure vessels of reactors [4]. They specialize in forging of rings with branch extrusion for the EPRs, and they process ingots of weight up to 500 tons, which is currently carried out only by the JSW.

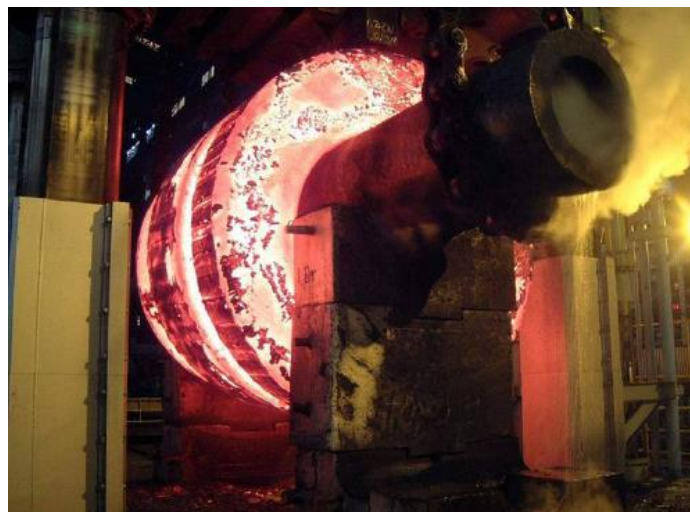

Fig. 7 The scheme of forging of a neck ring part for pressure vessel of the EPR reactor.

2.11 Sheffield Forgemasters International,

The company was founded as early as in the year 1750. At present they operate a press of 100 MN (Fig. 8), on which they manufacture 300-ton ingots. Their intention is to invest in installation of a press of 150 MN for forging ingots up to 500 t. At present time the forge is equipped with:

- Forging press of 100 MN being served by a rail manipulator of 300 tm, the workplace is fully integrated and it is controlled centrally by a computer. For the press operating there are even three bridge cranes ($2 \times 330 \text{ t} + 100 \text{ t}$), and auxiliary cranes ($1 \times 120 \text{ t}$) and 40 t for service ensuring,
- 40 MN-press being equipped with a rail manipulator (80 mt), the workplace is fully integrated, with forging to the dimension with the accuracy of $\pm 1 \text{ mm}$,
- 25 MN-press with a rail manipulator of 50 tm and a mobile manipulator of 8 t. The press workplace by 2 bridge cranes ($1 \times 70 \text{ t} + 15 \text{ t}$) a ($1 \times 30 \text{ t} + 10 \text{ t}$),
- Up-to-date heating furnaces being heated by natural gas and equipped with sophisticated control elements for ensuring the accurate temperature,
- Comprehensive equipment with smith's tool to creation both hollow and solid forgings of irregular shapes weighing up to 200 t, with ensuring an extremely precise control of sizes and optimum metallurgical properties of forgings.
- Gas horizontal furnaces controlled by a computer of their capacity up to 250 t with successive heat treatment (Fig. 9), and successive hardening in oil, in water and tempering,
- Vertical electric resistance furnace of maximum sizes of manufactured forgings with the diameter of 3.7 m, the furnace depth is 21.5 m .

The Sheffield Forgemasters International manufactured heavy forgings for British nuclear power plants.



Fig. 8 Hydraulic press of 100 MN for open die forging



Fig. 9 Heat treatment of longitudinal forgings
Maximal dimensions of forgings: of the shaft: $D = 3,000$ mm, length $L = 25,000$ mm; rings = $5,000$ mm; hollow bodies $D = 4,300$ mm; circular plates $D = 5,500$ mm

2.12 OMZ je Izhorskiye Zavody

In the year 2008 when the company completed the first phase of rebuilding of its 120 MN-hydraulic press they claimed to be the largest in Europe. In the second phase the power capabilities of the press were increased to 150 MN. In mid 2009 the steel plant enabling the complex manufacture of 600 ton-ingots with the diameter of 5.5 m was put into operation. With utilization the 600 ton-ingot the capacity of the forge was increased. Among forgings can be included parts for the reactor pressure vessels, steam generators, pressurizers, piping of primary circuits, and other heavy forgings.



Fig. 10 Heat processing of a roughed-out ring

The OMZ Group is one of the five biggest world's leading producers of large and very large special steel forgings destined for conventional and nuclear power engineering, metallurgy and mechanical engineering, petro-chemistry, and also for other strategic branches. Together with the Japan Steel Works, Japan Casting & Forging Corporation (JCFC), Kobe Steel Group and Doosan Heavy Industries & Construction Co, that are able to manufacture huge and very special products of steel for conventional and nuclear power engineering, metallurgy and mechanical engineering the OMZ uses four hydraulic forging presses for manufacture of forgings of special steel. So, they are able to manufacture and deliver a wide assortment of

forgings of weights ranging from 150 kg to 245 t, with dimensions from 3,500 mm, rings of diameters up to 6,500 mm (Fig.10), and longitudinal forgings of their lengths up to 20,000 mm.

2.15 Lehigh Heavy Forge, Pennsylvania

They have operated for more than a century and they have focused on manufacture of the largest forged pieces by the open die forging method destined for a wide range of industrial branches. They own the biggest press for open die forging (100 MN), in the North America that can handle ingots with the diameters up to 3.3 m and with weights of 270 t (Fig. 11). The Lehigh Heavy Forge Corporation of Bethlehem, Pa is the only one manufacturer of extremely heavy forged pieces made by the open die forging method in the Western Hemisphere of the Earth [5]. The 100 MN current computer-controlled oil-hydraulic press was built in the year 1983. The smaller 30 MN press was rebuilt to oil-hydraulic one in the year 1998. The company name had been also evolved and in the year 1997 they were renamed to the Lehigh Heavy Forge. Today the LHF is a leader in manufacture of components for the Navy, pressure vessels, forgings for conventional and nuclear power plants, ship drive shafts and other huge industrial components.



Fig. 11 Ingots heating in a movable-bottom furnace

Large forgings produced in the LHF are characterized with a high purity of the steel from which the ingots up to the weight of 300 t are cast. The ingots are cast in the factory of the Company Arcelor Mittal Steelton. The LHF has got two forging presses: 30 MN-press and 100 MN-press for large parts. The presses are equipped with rail manipulators. Heat processing of large forgings is carried out in chamber furnaces with dimensions of their hearths up to 5,000 mm (width) 21,000 mm (length). For hardening/quenching there are used a horizontal tank of dimensions: 15,500 mm (length), 3,500 mm (depth), and a vertical tank of its diameter of 6,500 mm.



Fig. 12 Ship drive shaft forged on the 100 MN-press in the forge of the Lehigh Heavy Forge

The LHF is a global supplier of working rolls for cold rolling mills. They deliver forgings for pressure vessels, as bottoms, caps, rings and they also manufacture forgings for conventional and nuclear power engineering and other branches. The LHF can also deliver forgings for ship drive shafts (Fig. 12), for mainpieces of rudder for the shipping industry. They also produce forgings for nuclear drive of seagoing ships.

3. Development of Czech forges for open die forging

Our big forges have one dissimilarity that they are a part of large corporations privatization of which was very complex and was realized rather late and not always successfully. Let's go through single enterprises.

Another uniqueness of our country is that considering our country size there are unusually high capacities of forges for open die forging. It is related to the fact that under the Austro-Hungarian Empire the heavy industry was centralized in the Czech Lands. Even after the Empire disintegration trade flows continued, e.g. shipyards on the Adriatic coast kept in taking parts for ship building from our enterprises. Under the era of the socialism there were supported the heavy industry and a strong manufacture of arms. After the social system change, the manufacture of arms was cancelled. It is appropriate to recall that in foreign companies where the manufacture of arms has been retained it has a stabilizing function. For example, in the crisis year 2009 it was not limited.

At the time of building nuclear power plants in Jaslovské Bohunice, Dukovany, Temelín and Mochovce the forges of our country ensured manufacture almost all forgings [5]. A smaller part of products were delivered even abroad. Interruption of that production affected significantly not only forges of our country.

3.1 The Forge VÍTKOVICE HEAVY MACHINERY (VHM)

This company transformation was not very successful. Only after establishment of the present proprietary relations the forge started to develop. Very significant investments were undertaken. A manipulator was installed with carrying capacity of 160t for the 120-MN press. It should be highlighted that it is the company's own product did under a foreign licence. The manipulator was quickly run in and nowadays it is fully utilized. It allows also an

automatic operation, which when forging bars it can comprise economy in time of 20 – 30 %. All furnaces in the forge were re-built to natural gas, recently they have used CO-gas. At all furnaces there was ensured measurement of oxygen content in flue gases. This measurement reduces the gas consumption, scale formation and limited the occurrence of surface defects. Another big investment there was installation of a radial forging machine for re-forging ingots up to diameters of 800 mm. Meanwhile some smooth bars of round and rectangular cross sections are forged (Fig. 13, 14). It has been even mastered forging of nickel alloy. In the future it is taken into account forging of recessed forged pieces and also hollow forgings, either as pipes or as hollow recessed forgings. The radial forgings machine has got sufficient output to replace their production, though not in the whole range. The fate of presses of 60 MN and 16 MN on which crankshafts in the die are forged has not been decided yet. In that event that there will be enough orders, for example in connection with the completion of a construction of the Temelin’s NPP, they could be operated also in the future. However, there is a need to modernize the presses and namely to acquire a manipulator.



Fig. 13 Round rod forged on the radial forging machine



Fig. 14 Large square bars forged in hydraulic presses

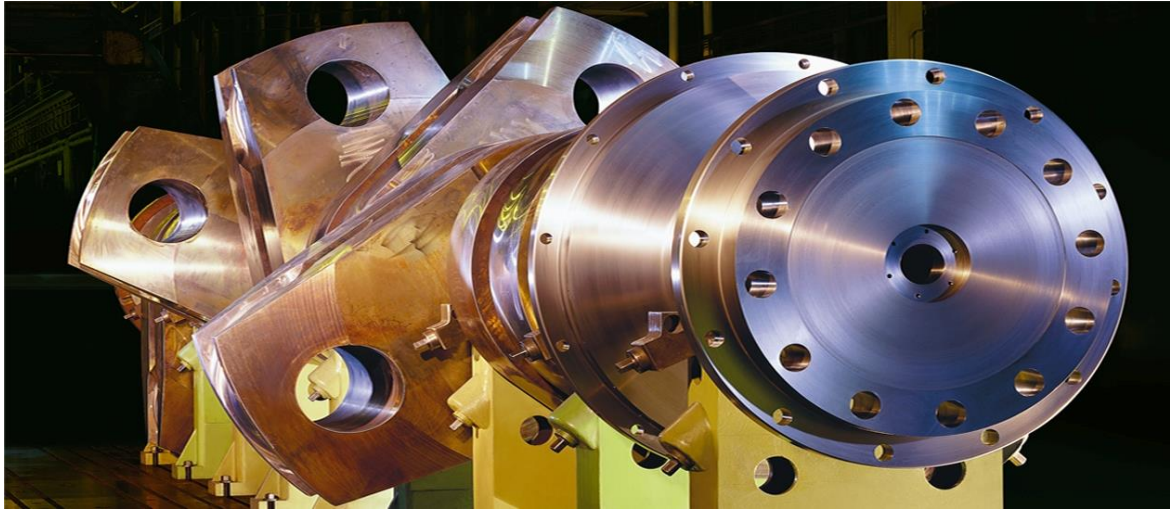

Fig. 15 Crankshafts in the boom times are the principal program of many forges

3.2 The Forge PILSEN STEEL

The large and small forges of the former Škoda Plzeň were privatized by different interested persons. So at present there are the PILSEN STEEL and the CPF Plzeň. Within the first years the forge developed quite successfully, but in mid 2012 there were difficulties with ensuring the plant running in consequence of which the operation was shut down. After some changes in ownership the forge was started up again at the beginning of the year 2013.

Even in the year 2011 there was built a new press of 90/120 MN and now it is prepared acquisition of a manipulator. And the furnaces capacity was enlarged for the press. And further, a press of 30 MN with a rail manipulator is operated in the forge too. The forge is therefore prepared for a modern operation.

Forgings for power engineering always formed a significant proportion of their assortment. And they remain in the product range at present. Recently the proportion of drill rods manufacture has arisen, as well as job orders for nuclear power engineering.

3.3 The Forge ŽĎAS

That enterprise privatization was successful and beneficial. The forge machinery has been continuously modernized, because presses as well as manipulators belong to the enterprise production range. Today in the forge they operate the 6.3 MN-press with a manipulator with its carrying capacity of 3t, the 16 MN-press with a manipulator of 8t (Fig. 16) which has replaced the original 12.5 MN-press and the 22.5 MN-press with a manipulator of 12t which has replaced the 18 MN-press. All presses are connected to manipulators and allow an automatic control.

The enterprise itself utilizes the forge products up to about 20 %, the rest are external orders. Recently the proportion of forgings destined for extraction of gas and oil from the seabed (so called off-shore extraction) has increased. These are pipes, pipe fittings and other forgings. On the other hand the proportion of forgings destined for wind power plants has dropped. But even in this forge the increase in demand for forgings destined for nuclear power plants has been recorded, too. In the production range of this forge there are blocks of tool steels and their proportion has increased. Today they form approximately 15% share. The recessed shafts have got the largest share in the forge assortment, about 20 %. Only a little smaller there is the proportion of eccentric and moulded forgings. And we can then place rings and bushings. The proportion of smooth bars and rods ranges around 10 %. The example of these forgings are given in the Figures B and C. The proportion of forgings of plain carbon steels

has dropped, today it is about 10 %, but the sales of forgings of low-alloy steel has increased. However, the sale of forgings of stainless steels has dropped, too.



Fig. 16 Press 16/12.5 MN before completing



Fig. 17 The ball forging



Fig.18 Recessed forgings

4. Conclusion

The forges manufacturing open die forged pieces are exposed to pressure caused by the growth of prices of steel and energies. It makes no difference that the forges and the steelworks are a part of the only one enterprise, because the growth of steel prices is due to the growth of the scrap iron and other raw materials.

At present the most of forges manufacturing open die forged pieces pins their hope to forgings for conventional power plants, but namely for nuclear power plants. The critical problem as for acceleration of construction of a nuclear power station is the availability of heavy namely for these units with more than 1,100 MWe. The interest is not only in heavy forgings for the reactor pressure vessels, forgings for the reactor pressure vessels, steam turbines and generators, but also in other components.

The forgings for construction of NPP with the reactors 3⁺: the manufacture of forgings requires large power presses, the parts of pressure vessels should be forged on forging presses of the power 140 – 150 MN. These presses allow processing steel ingots of the weight ranging from 500 to 600 t. As with other technologies, also in forging technology due to reducing demands for forgings, increasing prices of steels and energy costs there has happened considerable growth of the forge costs. New investments to large forges and steelmaking technologies are dependent on the customer's current offers of forgings and cannot be enforced only on the basis of the actual need of rebuilding or planned innovations. The customers who purchase forgings for NPP require more and more often large and integral forgings although in some cases it is possible to use split forgings that can be welded together into one unit then. These welds shall be however checked throughout the whole service life of the equipment. If we compare e.g. reactor weights, the reactors of the 2nd (II) generation required up to 2,000 t of forgings. Current constructions as e.g. "EPR" and "AP1000" require double weights of forgings.

Questions:

1. What assortment of forgings can be forged on radial forging machines?
2. What possibilities are as for weights and dimensions of forgings manufacture within the Czech forging industry?

Tasks to solve:

1. Compare machinery, manufacturing programme and standing of forges in the Czech Republic with forges abroad.
-

The literature to subsequent studies:

1.KUSHNAREV, A. V. et al. Production of high-quality railroad wheels. Steel in Translation, 2010, Vol. 40, Issue 3, pp 268-272 .

2.ROCKSTROH, B., KAPPES, V. et al New systems for the testing of rail wheels and wheel set axles. 7th International Rail Vehicle Conference, February 23rd - 25th , Dresden 2005.

2. METAL FORMING MACHINES

Chapter contents:

- Metal forming machines utilized impact energy - power hammers
- Power presses
- Radial forging machines and forging rolls
- Using single types of metal forming machines in forges



Time needed for studying: 120 minutes

Aim: After studying this chapter you will:

- be able to specify the basic constructional solution of metal forming machines
- be able to calculate the deformation energy
- be able to choose a type of a metal forming machine suitable for forging



Explication

Power hammers and presses are the metal forming machines used in forges. With the forming machines the most important there are the force that they are able to induce (hydraulic and crank presses) and/or the energy they have at their disposal to strike a single blow (power hammers and screw presses). Other important parameters of metal forming machines are: tool velocity, frequency of blows, strokes.

2.1 Power hammers

With the power hammer the forming work is performed predominantly thanks to kinetic energy of the moving ram. According to the method of the ram lifting we distinguish: drop hammers, mechanical / gravity drop hammers, compressor hammers, steam hammers.

2.1.1 Drop hammers

Drop hammers are used for both open die forging and drop forging. The hammers for drop forging work with a higher rate of accuracy of the forged piece dimensions. Currently the maximum weight of the ram of the drop hammers is about 10^3 kg. The cause of limitation is particularly unsatisfactory working environment, vibrations arising from the hammers

operation are spreading to the surrounding area and may affect adversely precise machinery running or even damage the building statics.

2.1.2 Spring hammers

Spring hammers are driven by a crank mechanism through the assembly of leaf springs. They are mainly used in small forges at the piece production by the method of open die forging.

2.1.3 Counter strike hammers

Counter strike hammers - drop hammers have got two rams that move against each other. One the conventional workmanships can be seen in the Figure of the counter strike hammer with a mechanical coupling.

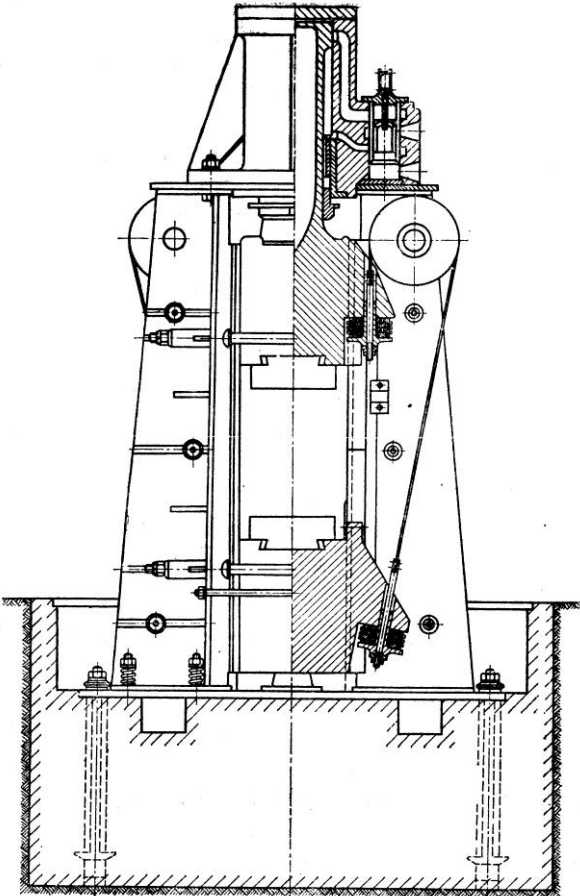

Fig. 2.1. The counter strike hammer with a mechanical coupling

The upper ram is lifted by compressed air and when dropping it is accelerated by it. The upper ram is connected to the lower ram by belts. When forging the both rams are moving against each other at the same velocity, so at the impact they do not produce excessive vibrations. They are used only for drop forging. The counter strike hammers with big deformation energy are provided with rams with hydraulic and air-hydraulic couplings.

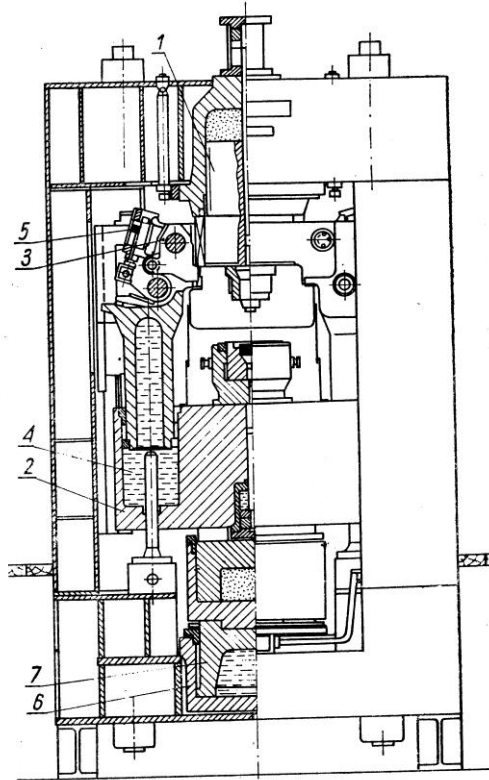

Fig. 2.2 The counter strike hammer with a hydraulic coupling:
1) working roll and upper ram, 7) lower hydraulic rolls

The weight of a lower ram m_b is bigger than the weight of an upper ram m_h . Diameters of hydraulic rolls are chosen so that the following condition would be met for velocity of the lower ram v_d and for the velocity the upper ram v_h :

$$m_s \cdot v_s = m_h \cdot v_h \quad (2.1)$$

where

m_h, m_s these are weights of lower and upper rams
 v_h, v_s these are velocities of upper and lower rams

Air-hydraulic hammers are designed in such a manner that the bottom swage is connected to the machine frame. The upper ram is lifted hydraulically, the lower assembly is lifted pneumatically.

2.2. Power presses

Power presses are used solely for drop forging.

2.2.1 Screw presses.

The forming force is induced by a screw with a motion thread (a spindle). The most widespread type of a screw press with a spindle driven by friction disks is in the Figure 2.3.

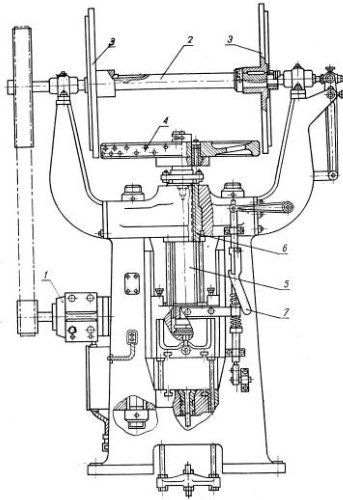

Fig. 2.3. Friction screw press

1 – drive, 2 – shaft, 3- friction disk, 4 – flywheel, 6 - screw and nut

2.2.2 Screw presses with a direct drive

The ram is connected with a screw that is connected to a flywheel in its upper part. In the upper (top) part of a press there are two friction disks driven by an electric motor. The friction disks are fitted slidably on the common shaft and they are pushed against the flywheel alternately and thus the screw is started turning and the ram starts moving either upwards or downwards. There are used several types of screw presses with a direct drive of a flywheel. The most simple is the drive by an electric motor. The flywheel is the electric motor rotor as well. This type has got the lowest energy consumption of all metal forming machines and it allows setting-up precisely. Some types of screw presses have a hydraulic drive. In the Fig. 2.4 there is a screw press with a hydraulic drive.

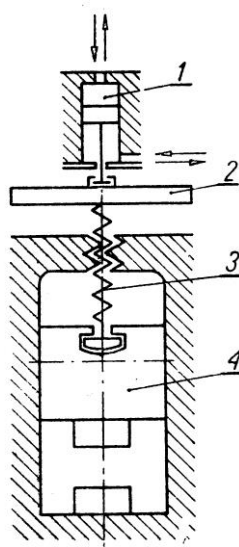

Fig. 2.4. Screw press with a hydraulic drive

1 – hydraulic motor, 2 – flywheel, 3 – screw, 4 - ram

2.2.2 Crank presses

The crank presses rank among the most used machines in forges destined for drop forging. In the upper part of the press there is a flywheel with a horizontal axis driven by an electric motor. The flywheel shaft is coupled to a crankshaft through a coupling assembly. To the crankshaft a connecting rod being coupled to a ram is connected too. After the coupling switching-on the ram completes only one stroke and it stops in the upper/top position.

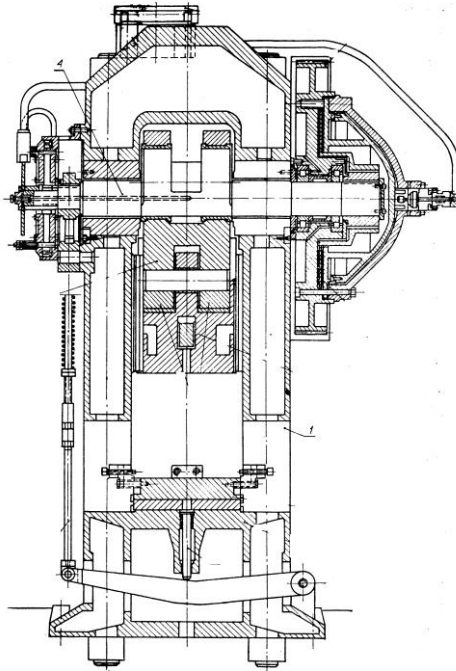

Fig. 2.5. Scheme of crank press (Maxi)
1 – frame, 2 – crankshaft, 3 - flywheel

This press has a main shaft mounted transversely, or with the biggest crank presses the main shaft is positioned lengthwise. Besides some presses with only one crank, there are presses with two cranks on one shaft and with two connecting rods that power a ram. Crank presses have a constant stroke. An important feature of crank presses is the stiffness. In drop forging the forging force can vary, for example due to fluctuations of heating temperatures, an uneven layer of lubricant, etc., and consequently there may occur some variations in deflection of those parts of the press that transmit the moulding force, and thereby the thickness of the forgings may vary too.

2.2.3 Horizontal forging machines

Horizontal forging presses have two movable press die parts. The working part consists of a fixed portion of a die, a movable portion of a die and a ram. The ram is driven by a crank mechanism, the movable part of the die is driven by a lever mechanism.

2.2.4 Toggle-lever presses

The operation principle of the press is shown in the Fig 2.6. Between the upper part of the frame and a ram there are two levers forming a toggle. The levers are moved by a crank mechanism. These presses are characterized by a small constant strike and high stiffness. Deformation of the crank mechanism does not affect the rigidity/stiffness of the press. They are mainly used for calibration of forgings.

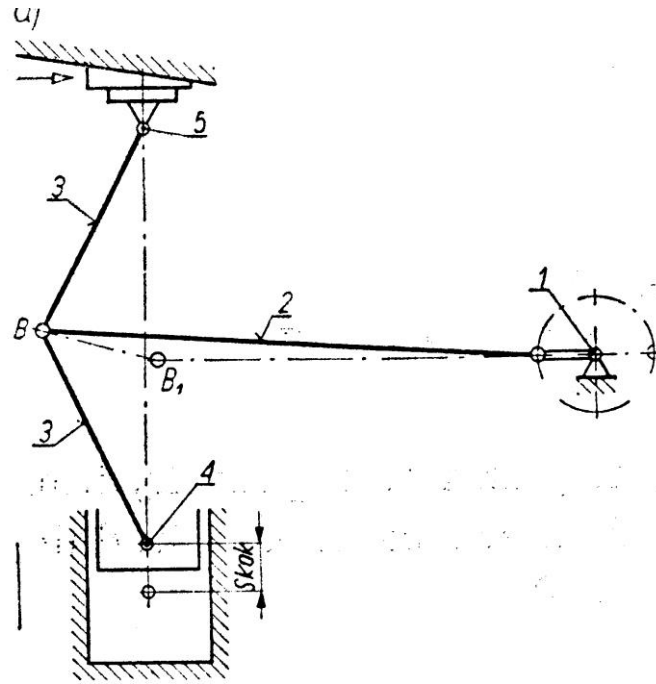

Fig. 2.6. Kinematic scheme of a toggle-lever press
 1 – crank shaft, 2 – main lever, B – toggle

2.2.5 Wedge presses

The principle of their operation is simple: between the ram and the upper part of the frame there is a wedge that moves horizontally. The wedge may be driven by a crank mechanism, then these presses have a constant stroke, or it may be driven hydraulically. These presses are characterized with a rather small stroke however they can withstand the strongest eccentric forces.

2.3. Radial forging machines

The machines are usually provided with four swages which are destined for forging longitudinal forged pieces. The drive of swages is either of mechanical or hydraulic type. Radial forging machines with a mechanical drive are used for cold forming of small cross sections. For hot forging of large cross sections there are used machines with a hydraulic drive. There are four pumps driven by a motor that are directly coupled with squeezing cylinders which force on the swages through the push rod. Besides four-swage machines there are also used machines with different numbers of swages.

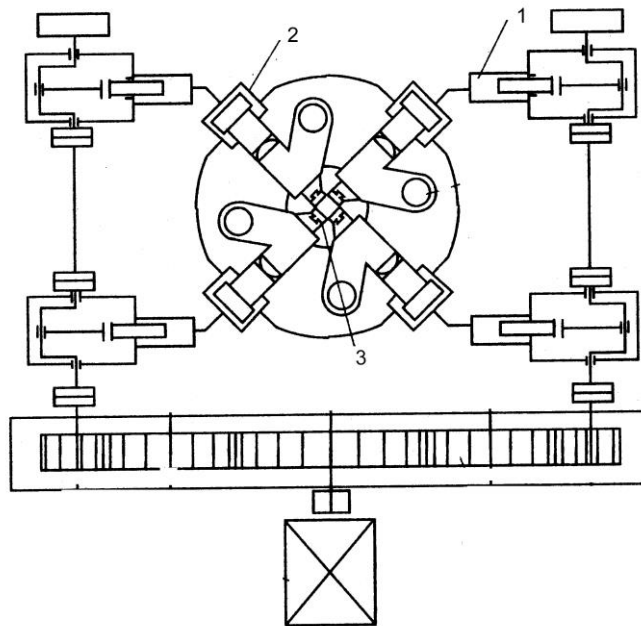

Fig. 2.7. The scheme of radial forging machine

2.4 Forging rolls

Forging rolls are used for preparation of slugs for drop forging. Basically it is an adapted duo-rolling-mill stand.

2.5 Application of single types of metal forming machines

Criteria for the choice of forming machines are listed in the following tables.

Table 2.1. The use of hammers

Hammer	Forging	Impact velocity max. [kJ]	Number of blows [m ⁻¹]	Forged pieces
Spring hammer	Open die forging	0,5	350	Weight of smith forging max. 50 kg
Air-steam hammer	Open die forging	-	40	Weight of smith forging max. 500 kg
	Die forging	15	-	Drop forging
Hydropneumatic hammer	Open die forging	40	240	Weight of smith forging max. 1000 kg
	Die forging	200	80	Drop forging

Table 2.2. Technological possibilities of presses and radial forging machines:

Forging machine	Procedure	Deformation force max. [MN]	Striking rate [s ⁻¹]	Use
Friction screw press	Die forging	7	25	Precision forging
Screw press	Die forging	40 (315)	-	Forging to close tolerances
Crank forging press	Die forging	60 (160)	100	Precision die forging
Horizontal forging machine	Die forging	12/12	35	Forging from bar
Hydraulic press	Smith forging	150	120	Large open die forging
	Die forging	30 (750)	-	Isothermal forging
	Extrusion	350	-	Hot forming

The blow power W with the steam-and-air hammers and the mechanical drop hammers is given by the following relation:

$$W = \frac{1}{2} m_b v_b^2 \quad (2.2)$$

where W it is blow power of a drop forging hammer,
 m_b weight of a ram,
 v_b velocity of a ram at impact,

For counter strike hammers the following relation is applicable:

$$W = \frac{1}{2} m_h v_h + \frac{1}{2} m_s v_s \quad (2.3)$$

where m_h , m_s it is the weight of the upper and lower rams,
 v_h , v_s it is the velocity of the upper and lower rams at impact.

With the counterblow forging hammer with a mechanical coupling the both rams have the same weight and velocity, so the following relation is valid:

$$W = m_h v_h \quad (2.4)$$

Deformation power of crank and toggle presses changes along their path in dependence on kinematics of the given machine. As rated it is considered the power that the press is able to induce about 5 mm from the bottom dead centre.

For operations requiring high strength and relatively little forming work some power/energy machines are more appropriate. As an example we can give turbine blades which are predominantly forged on hammers. However, if the forming processes require much work (power acts throughout the whole path) the hydraulic presses are more suitable. As examples

we can give ramming or extrusion. Forgings that become cool rapidly, e.g. small forgings and forgings of copper alloys and aluminium alloys, should be forged on hammers.

2.3. Metal forming machines suitable for individual procedures of forging

Forging of forged pieces of weight above 1kg in dies	Crank press
Forging of the largest drop forgings	Hydraulic press
Forging of aluminium and copper alloys in dies	Hammer or friction press
Drop forging of smaller series of forged pieces	Hammer
Drop forging of large series of forged pieces	Crank press
Open die forging of forged pieces of weight up to 100kg	Steam-and-air hammer
Open die forging of forged pieces above 100kg	Hydraulic press

Many procedures and types of forging may be carried out either on a hammer or on a press. In such a case it is possible to use the table of equivalents of hammers and presses.

Tabulka 2.4. Equivalent of hammers and presses

Rated power of hammer [kJ]	Press power [MN]	
	Rated	Maximum
10	15	20
20	26	33
30	36	46
40	47	59
50	57	69

Speed of operation with single types of metal forming machines is another characteristic of metal forming machines. This is the maximum speed of operation. With power presses the speed changes according to a machine kinematics.

Table 2.5. Speeds of operation with single types of metal forming machines

Machine	Velocity of motion of press tools [ms ⁻¹]
Hydraulic press	0.02 to 0.45
Crank press	0.03 to 1.5
Friction press	0.3 to 1.2
Spring hammer	2 to 3
Single-acting hammer	3.6 to 5.4
Double-acting hammer	4.5 to 9
Counter strike hammer	6 to 12
Pneumatic hammers	up to 50

Tolerances of the height at a forging forged on a swage hammer are rather small, because the dies bear on each other. Tolerances in the transverse direction are larger, because the ram guidance is not as accurate as with the crank presses. When forging on any crank presses it is quite contrary. Tolerances of the height are adversely affected by metal excess and subsequently by the press springing-back, tolerance of dimensions perpendicular to the forging axis are closer. As for investment and operation the hammers are much cheaper. From the economic point of view the hydraulic presses are more expensive and their maintenance is more demanding too. As for open die forming, the radial metal forming machines have got the highest performance efficiency. However the service life of the hammer drop dies is much longer, because materials are in contact with a tool for a shorter time. And with hammers there are used bigger draughts. Provided a forging is suitable either for forging on a press or on a hammer, it emerged that using a hammer is more economical for smaller series, and for bigger series the crank press seems to be more advantageous.

Questions:

1. What relations for calculation of deformation power do you know?
 2. On what principle do the counter strike hammers operate?
 3. What is the velocity of forging tools of individual forging machines?
 4. What press do you choose for open die forging of the forged pieces with the weight of 50 t?
-

Tasks to solve:

1. Calculate optimum relative length of movement/engagement for the rectangular cross section with the height of $a = 700$ mm.
 2. Calculate deformation strength and deformation work when lengthening the rectangular cross section of 700×500 mm. The semi-product is of steel of the class 12 600.
-
-

The literature to subsequent studies:

1. KUSHNAREV, A. V. et al. Production of high-quality railroad wheels. Steel in Translation, 2010, Vol. 40, Issue 3, pp 268-272 .

2. ROCKSTROH, B., KAPPES, V. et al New systems for the testing of rail wheels and wheel set axles. 7th International Rail Vehicle Conference, February 23rd - 25th , Dresden 2005.

3. HEATING IN FORGES

Chapter contents:

- Basic physical quantities of heating
- Forging temperatures
- Rate of heating
- Time of heating



Time needed for studying: 120 minutes

Aim: After studying this chapter

- You will be able to appreciate basic quantities for metal heating in forges
- You will be able to establish procedures of steel heating in forges
- You will get to know the methodology of classification of heated semi-products as thick and thin ones
- You will be able to calculate time and rate of heating



Explication

Introduction

Heating before forming process should facilitate reaching the forming temperature in the shortest time without running a risk of decline in surface and internal quality of a body being heated, while suppressing side effects of heating as burn-off, decarburization, grain coarsening and overheating.

The optimum heating can increase formability and even can reduce distortional resistance of steel (10 to 15 times), which has a positive effect on energy intensity of forming, forming tools service life and production rate of a forming process. If temperature is rising, diffusion processes can be speeded up (casting structure homogenization, dissolution of precipitates). Heating reduces the quantity of lattice defects. Heating problems mastering is conditioned by knowledge of selected physical quantities of metals: thermal conductivity, specific thermal capacity, density, thermal conductance, thermal line expansion, elastic and plastic properties.

3.1 Thermal conductivity (λ)

For iron, the value λ is about 75 W m⁻¹ K⁻¹. The additive elements decrease this value. For the conductivity of ferritic (λ_f), pearlitic (λ_p), martensitic (λ_m) and austenitic (λ_a) steels the following inequality holds:

$$\lambda_f > \lambda_p > \lambda_m > \lambda_a \quad (3.1)$$

Thermal conductivity is decreased due to quantity of lattice defects which are typical for the following structures: cast, cold formed, hardened.

According to the dependence of λ on temperatures the steels can be divided into three groups. In these groups the specific thermal conductivity is changed in dependence on rising temperature as follows:

- 1) It is significantly decreased (low carbon and low alloy steels),
- 2) It is decreased slightly or remained almost constant (medium-alloy steel),
- 3) It is slightly increased (high-alloy steels).

With increasing temperature the differences in specific thermal conductivity of individual types of steel gradually equalize and at temperatures above 900 ° C, the value is $\lambda \approx 25 \text{ W m}^{-1} \cdot \text{K}^{-1}$.

Specific thermal conductivity of carbon steels at a temperature of 0 ° C can be calculated from the relationship:

$$\lambda_0 = 1 / (0.0105 + 0.0202 C_e) \quad (3.2)$$

where w_i is a content by weight of i -th element in the steel [%]; Ar_i is the relative atomic weight of i -th element, C_e is the carbon equivalent ($C_e = \sum 12 w_i / Ar_i$ [%]).

For the temperature range below the transformation temperature $\alpha > \gamma$

$$\lambda_t = 419/Z \quad (3.3)$$

where Z can be calculated from the following empirical relation:

$$Z = 5.5 + 0.1\delta^2 + 0.35\delta + 2.2 w_c (1 - 0.1125\delta) - 4.5 w_{Si} (1 - 0.125\delta) + 1.9 w_{Mn} (1 - 0.1125\delta) - 0.64 w_{Cr} (1 - 0.1\delta) + 0.9 w_{Ni} (1 - 0.125\delta) \quad (3.4)$$

where w_i is the content by weight of i -th element in the steel [%]
 δ can be determined from the relation: $\delta = 0.01 t$ [° C]

For the temperature range above the transformation temperature $\alpha \rightarrow \gamma$

$$\lambda_t = \lambda_{\alpha/\gamma} + (29 - \lambda_{\alpha/\gamma}) \cdot (t - t_{\alpha/\gamma}) / (1200 - t_{\alpha/\gamma}) \quad (3.5)$$

where $\lambda_{\alpha/\gamma}$ is the specific thermal conductivity of steel at a temperature of transformation of $\alpha \rightarrow \gamma$,
 $t_{\alpha/\gamma}$ is the transformation temperature $\alpha \rightarrow \gamma$.

The higher is a specific thermal conductivity, the faster the heat transfer from the surface to the core of a heated body, less heat stress and a shorter heating time.

3.2 Specific thermal capacity (c_p)

For the steels at room temperature, $c_p = 469\text{-}511 \text{ J kg}^{-1}\text{K}^{-1}$ and for the carbon steels in the temperature limit 0 to 100 ° C:

$$c_p = 467 + 19w_C \quad (3.6)$$

where w_C it is the content by weight of carbon in a steel [%].

The influence of chemical composition is insignificant. With rising the temperature, the specific thermal capacity of steel is rising too up to a maximum at the temperature of transformation $\alpha \rightarrow \gamma$. At temperatures around 1000 °C the c_p -value moves around 511 Jkg⁻¹K⁻¹. The higher is the specific thermal capacity, the longer is the heating time and the greater is the energy intensity of heating.

3.3 Density (ρ)

The density of technically pure iron is 7,880 kgm⁻³. For steels it is determined from the relation:

$$\zeta_0 = 7876 - 40w_C - 16w_{Mn} - 73w_{Si} - 164w_S - 117w_P + 11w_{Cu} + 4w_{Ni} + w_{Cr} + 95w_W - 120w_{Al} \quad (3.7)$$

where w_i it is the content by weight of i -th element in the steel [%].

For carbon steels $\zeta = 7,800$ to $7,850$ kgm⁻³ for high-alloy steels tungsten-alloyed up to $8,690$ kg.m⁻³.

For the density of austenitic (ζ_a), bainite (ζ_b), pearlitic (ζ_p), and martensitic (ζ_m) steels the following is valid:

$$\zeta_a > \zeta_b > \zeta_p > \zeta_m \quad (3.8)$$

The dependence on temperature it is described by the following relation:

$$\zeta_t = \zeta_0 / (1 - \beta_t) \quad (3.9)$$

where β_t it is the thermal volume expansion [K⁻¹].

The higher is the density, the longer is the heating time and the greater is the energy intensity of heating.

3.4 Thermal conductance (a)

It expresses the ratio of the heat supplied to the heat necessary to heat the given body:

$$a = \lambda / (c \cdot \zeta) \quad (3.10)$$

where a it is the thermal conductance [m²s⁻¹]. The thermal conductance influences affects the rate of heating of steels:

$$\begin{array}{ll} \text{carbon steel at the temperature of } 0^\circ\text{C:} & a = 111 \text{ to } 166 \cdot 10^{-7} \text{ m}^2\text{s}^{-1}, \\ \text{alloy steel} & : a < 111 \cdot 10^{-7} \text{ m}^2\text{s}^{-1}. \end{array}$$

The temperature dependence is very similar to that of the thermal conductivity:

$$\text{at } t > 900 \text{ }^\circ\text{C for the most of steels } a \approx 39 \cdot 10^{-7} \text{ m}^2 \text{ s}^{-1}.$$

The higher is the thermal conductance, the shorter is the heating time, and the lower is the energy intensity of heating.

3.5 Thermal line expansion (α)

As for the iron it is at the temperature of 0 °C:

$$\alpha = 11.7 \cdot 10^{-6} \quad (3.11)$$

where α it is the thermal line expansion [K⁻¹].

The influence of carbon on the α value is negligible. The largest thermal expansion coefficient, $\alpha = 16$ to $20 \cdot 10^{-6}$ K⁻¹, can be found out in austenitic steels. The larger is the thermal line expansion, the greater are thermal stresses in the heated body and the lower heating rate should be.

3.6 Mechanical properties

Mechanical properties have influence on the resistance of heated bodies to heat stress. In designing heating elastic properties of the material are analysed. They are described using the modulus of elasticity in tension. From its temperature dependence it follows, that at temperature values of 500 to 550 ° C and higher the most steels lose their elastic properties. The better are the plastic properties, the higher may be the rate of heating, and there occur only lesser thermal stresses, which allow heating speeding up and reducing its energy intensity.

3.7 Heat stresses (σ)

Thermal stresses arise in the heated body due to the increase of its volume. Surface layers warmed to a higher temperature tend to increase their volume, but there is still an area at the axis which is not warmed up thoroughly, so on the surface there can be generated pressure thermal stresses and at the axis the tensile thermal stresses, which are particularly dangerous in the temperature range 0 to 500 ° C when the steel is in elastic state.

When heating there may even stresses occur due to recrystallization and in some cases the residual stress as a result of the previous cooling must be taken into account. Recrystallization stresses are dangerous when heating alloy steels. During heating the thermal stresses must not exceed the allowable stress σ_D , which can be ensured by the permissible temperature difference ΔT in the body being heated. The permissible temperature difference is calculated as follows:

$$\Delta T = k \cdot \sigma_D / (\alpha E) \quad (3.12)$$

where ΔT is a permissible temperature difference allowable temperature difference over the cross section of the heated material [K]

- k shape coefficient: for a plate $k = 1.05$; for a roll $k = 1.4$;
- α thermal line expansion [K⁻¹],
- E modulus of elasticity in tension [MPa].

Majority of steels have $R_m = 600$ to 800 MPa. Permissible stress $\sigma_D = 300$ to 400 MPa, and a member in parentheses on the right side of the equation: $\alpha = 2.5 E$ MPa.K⁻¹. Under these assumptions, for the initial heating phase ($t < 550$ ° C) there is the maximum permissible temperature difference: 5 MPa.K^{-1} .

$$\Delta T_{\max} = 168 \text{ to } 224 \text{ K} \approx 200 \text{ K}$$

According to the size of the thermal stresses the heated semi-products can be divided into two groups:

- 1) Thin bodies ($\Delta T \rightarrow 0$), the thermal stresses need not be considered,
- 2) Thick bodies ($\Delta T > \Delta T_{\max}$), dangerous thermal stresses occur.

The inclusion of the heating element into a group is carried out according to the Biot criterion:

$$Bi = \alpha s / \lambda \quad (3.13)$$

where α coefficient of heat transfer [$W m^{-2} K^{-1}$],
 s calculated thickness [m]; for even heating $s = 0.5 t$, and for uneven heating $s = t$,
 t the actual thickness of a body [m],
 λ thermal conductivity [$W m^{-1} K^{-1}$].

For thin bodies $Bi < 0.25$, for thick bodies $Bi > 0.5$. The thickness from 50 to 100 mm is given for dividing the thin bodies and thick ones.

3.7 The range of forging temperatures

Hot forming is carried out at an interval of forging temperatures (Fig. 1):

- 1) top forging temperature (HKT) is the highest permissible temperature (measured in the furnace) to which the semi-product can be heated,
- 2) initial forging temperature (PKT) is the temperature at which the forging of the semi-product starts,
- 3) lower forging temperature (DKT) is the lowest permissible forging temperature,
- 4) finish-forging temperature (DT) is the temperature at the end of forging.

For the forging temperatures it is valid: $HKT \geq PKT$ a $DKT \leq DT$.

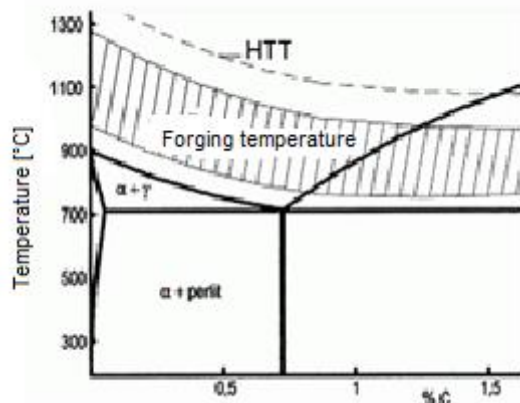

Fig. 1. Range of forging temperatures of steels

3.7.1 Top forging temperature (HKT)

Its determination is conditioned by respecting entirely antagonistic phenomena, when with rising temperature, the formability is improving and the deformation resistance is decreasing, which is advantageous in terms of forging, but simultaneously the oxidation and decarburization of the surface layers of the heated body are intensifying, as well as the

susceptibility to grain growth, overheating and burning are increasing, which are undesirable and even inadmissible phenomena.

The top forging temperature should be always lower than the critical temperature of the grain growth. With carbon steels at a given temperature the grain growth depends primarily on the carbon content, whereas with the alloy steels it depends on additive elements, in particular on carbide formers with the aid of which the grain growth can be slowed down. The most susceptible to grain growth are ferritic steels. Additive elements can generally decrease the top forging temperature, because with their increasing the susceptibility to overheating and burning is increasing and simultaneously the formability is getting worse, too.

With the semi-products with a casting structure the top forging temperature can be increased slightly to support homogenization of heterogeneous cast steel. At the same high level the temperature of forming is chosen e.g. in tube rolling mills when punching by oblique milling, thus using a method which realization is conditioned by a high formability of a punched semi-product.

The highest top forging temperature is applied for smaller semi-products with the speed heating, when short heating time does not allow the full outbreak of the accompanying phenomena of the heating process:

$$\text{HKT} = t_s - (150 \text{ to } 200) \quad (3.14)$$

where HKT it is top forging temperature [°C],
t_s it is the solidus temperature [°C].

3.7.2 Lower forging temperature (DKT)

It decisively influences the final properties of moulded steel. In its determination the following aspects shall be considered:

- 1) The steel must still have sufficient formability,
- 2) The deformation resistance of steel shall be in accordance with energo-power quantities of a forming device
- 3) The required properties of steel can be reached by an optimal combination of lower forging temperature, the last draught at forging procedure and a successive method of cooling.

The lower forging temperature is determined separately for hypo-eutectoid steels and hypereutectoid steels.

3.7.2.1 Hypo-eutectoid steels

Completion of forging high above the Ar₃ temperature and subsequent cooling of thick semi-products in air support static recrystallization, so that the resultant structure will be coarse-grained. Forging between the temperatures Ar₃ and Ar₁ is not also recommended because of a stress formed in two-phase structures, formability deterioration, occurring characteristic banding (ferrite is deformed easier than austenite) and increasing the anisotropy of mechanical properties. The lower forging temperature is calculated as follows:

$$\text{Ar}_3 < \text{DKT} < (\text{Ar}_3 + 50) \quad [^\circ\text{C}] \quad (3.15)$$

If the resulting structure is a fine-grained, the prerequisites will be created for optimum properties of forgings. In rare cases, lower forging temperature is chosen below the Ar₃ temperature with intent of improving certain properties of forgings, particularly of the elastic stress limit of spring steels, or an improvement in surface quality.

3.7.2.2 Hypereutectoid steels

In this case the lower forging temperature does not affect the homogeneous austenite area. Forging at finishing temperatures would result in creation of a coarse-grained structure, and during cooling there should be eliminated growth of continuous cementite network at austenite grain boundaries with adverse consequences for the plastic properties of forgings. The lower forging temperature is therefore determined by the expression:

$$Ar_{cm} > DKT > Ar_1 \quad (3.16)$$

Useful properties of forgings are obtained when carrying out finishing forging just above the Ar_1 temperature, which may be allowed provided that the favourable state of stress will guarantee high formability of steel.

Lower finishing temperatures (700 to 750 °C) are used during controlled forging of micro-alloyed steels, which together with the higher deformation (60 to 65%) at the temperatures $t < 900$ °C results in refinement of grains, in improvement of strength properties and increase in resistance to brittle fracture.

The resultant properties of forgings however do not depend only on the finishing temperature, but also on the size of the last draft/material removal, which is intended to prevent grain coarsening. Critical draft/material removal of metallic materials is determined from the recrystallization diagrams. For conventional steels the critical draft/material removal is usually 5 to 15%. High susceptibility to a critical grain growth can be found out in ferritic steels, the lower forging temperature in these steels is about 750 to 800 °C.

If after forging of semi-products of a smaller thickness a heat treatment with recrystallization follows, it is preferable to finish forming above the lower forging temperature ($DT > DKT$). Steel has got a higher formability and a lower deformation/distortional resistance, which simplifies the forming procedure, especially when forming forgings of an intricate shape. Very precise observance of the lower forging temperature ($DKT = DT$) requires a single-phase steel and semi-products of a greater thickness for which the forming process is the only one procedure to reaching refinement of grains and to achieving the desired properties.

3.8 Rate of heating

It depends mainly on the thermal conductance and also on the properties of the heated material, shape and dimensions of the heated body. The higher is the heating rate, the shorter can be the heating time (which is only seemingly favourable from the operational and economic view), but it also brings stronger thermal stresses in the heated body which are the decisive criteria for determining the rate of heating. Permissible heating rate can be determined from the relation:

$$c = k a \Delta T / s^2 \quad (3.17)$$

where

c	it is rate of heating [K h ⁻¹],
k	it is shape coefficient: for a plate $k = 2.1$; for a roll $= 5.6$,
a	it is a thermal conductance [m ² h ⁻¹],
ΔT	it is permissible temperature difference in a heated body [K]; it is calculated according to the relation (12),
s	it is a calculated thickness [m].

In order to maintain thermal stresses within allowable limits it is necessary to include thick semi-products preheating into the preliminary stage of the heating mode in a furnace with a

reduced charge temperature that is calculated for a cold charge ($T < 550 \text{ }^\circ\text{C}$), when neglecting the convective heat transfer with the aid of the following relation:

$$(T_p / 100)^4 = (T_m / 100)^4 + q / C \quad (3.18)$$

where T_p , T_m charging temperature of furnace [K], and charging temperature of material [K],
 C thermal conductance [$\text{Wm}^{-2} \text{K}^{-4}$]; for gas furnaces $C = 3,5$.
 q density of flow of heat [W m^{-2}],

$$q = 2 \lambda \Delta T / s \quad (3.19)$$

where ΔT it is a permissible temperature difference in a body being heated, according to the relation (10),
 s calculating thickness [m].

A similar procedure is used for calculating charging temperature of furnaces for a hot charge ($t > 550 \text{ }^\circ\text{C}$). The permissible temperature difference ΔT , calculated according to equation (10) is increased by 50%, which is possible thanks to reduced susceptibility of steel to thermal stresses. Lowest charging temperature ($300\text{-}500 \text{ }^\circ\text{C}$) shall be selected for a cold charge of thick semi-finished products of steel in the as-cast state (forging ingots) and with a low plasticity.

3.9 Time of heating

It should be as short as possible to achieve the smallest scale generation and minimum consumption of thermal energy, but long enough to achieve the required forming temperature, uniform warming ($50 \text{ K} \geq \Delta T \approx 1 \text{ KCM-l}$) and the smallest thermal stress. For some alloy steels the heating time must secure the required structural changes (e.g. dissolution of carbides at high speed steel or carbo-nitrides in micro-alloyed steels). The extension of the heating time above the calculated optimum can not be accepted for steels with a distinct tendency to grain growth (ferritic chromium and silicon steels). From simple empirical formulas for heating semi-products having a thickness $t > 100 \text{ mm}$, the following relation is used for chamber furnaces:

$$\tau = k_1 \cdot k_2 \cdot t \sqrt{t} \quad (3.20)$$

where τ it is a heating time [h],
 k_1 it is a coefficient declaring a material. For structural carbon and low-alloy steels $k_1 = 10$, for high-carbon and high-alloy steels $k_1 = 20$,
 k_2 it is coefficient covering influence of an arrangement of semi-products in a furnace (Fig.2)

For high carbon and high-alloy steels

$$\tau = \tau_1 + \tau_2 \quad (3.21)$$

where τ_1 it is the heating time from 0 to $850 \text{ }^\circ\text{C}$,
 τ_2 it is the heating time from 850 to $1,200 \text{ }^\circ\text{C}$.

For high carbon steels: $\tau_1 = \tau_2 = 10 k_2 \cdot t \sqrt{t}$, and for high-alloy steels:

$$\tau_1 = 13,5k_2 \cdot t\sqrt{t}; \tau_2 = 6,7k_2 \cdot t\sqrt{t}.$$

Arrangement of material	k ₂	Arrangement of material	k ₂
	1		1
	1		1,4
	2		2,2
	1,35		2
	1,3		1,8

Fig. 2. Dependence of the coefficient k_2 on arrangement of material in a furnace.

Questions:

1. Give principal physical and mechanical quantities for determination of a procedure of heating in forges.
2. For what purposes the Biot's criterion is used when heating?
3. In what interval the lower forging temperature of hypo-eutectoid and hypereutectoid steels can be found out s?
4. How can you calculate the charging temperature of a furnace for heating of cool semi-products with $Bi > 0,25$?
5. What empirical relations are used to determine the time of heating?

Tasks to solve:

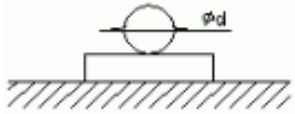
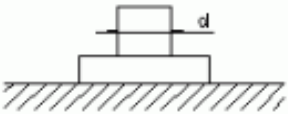
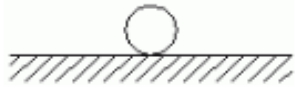
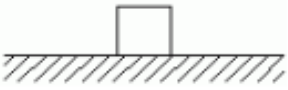
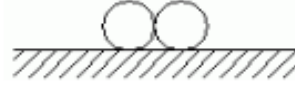
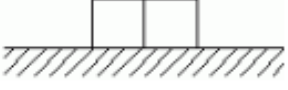
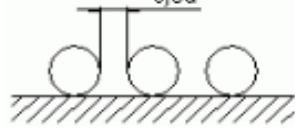
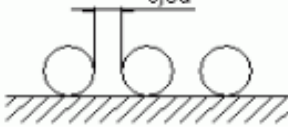
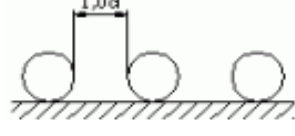
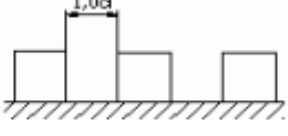
1. Determine the lower forging temperature for hypereutectoid steels.
2. Calculate the finishing temperature of a furnace for heating of forging ingots with the weight of 45,000 kg. Ingots are made of the steel 12 050.
3. Calculate the overall time of heating of the ingot from the task No. 2.

4. HEATING FURNACES AND HEATING IN FORGES

Chapter contents:

- Gas-fired reheating furnaces
- Electric heating furnaces
- Speed heating and heating in controlled atmosphere
- Forgings cooling



Time needed for studying: 120 minutes

Aim: After studying this chapter

- You will acquaint with single types of reheating furnaces
- You will be able to calculate the heating time with resistance and induction heating
- You will be able to determine a suitable speed of forgings cooling down from the finishing temperature



Explication

With open die forging the gas-fired are typically used. In forges for drop forging there are applied some other heating methods, mainly aiming to accelerate warming and decrease burnt-off and decarburization. These include electric heating, speed heating in controlled. Electric current is used for resistance and induction heating.

4.1. Gas-fired heating furnaces

Heating furnaces in forges have a wide weight range of heated semi-finished products and significantly variable character of production.

4.1.1 Chamber furnaces with horizontal hearth

They are used for heating small semi-products for open die and drop forging at single-part production or short-run production. The furnace in the Figure 1 is heated by burners in the side walls, and in their lower parts there are also exhaust flues placed through which combustion products flow to a recuperator.

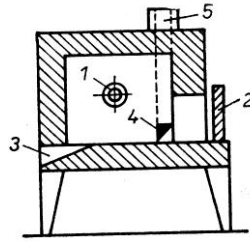

Fig.1. Scheme of chamber furnace: 1 - burner; 2 - door; 3 – slag hole; 4 – exhaust flue; 5 – recuperator

4.1.2. Chamber slot furnaces

They are suitable for finishing heating of rods and bars destined for local forging. The furnace in the Figure 2 has its charging door along the front wall replaced by a narrow slot.

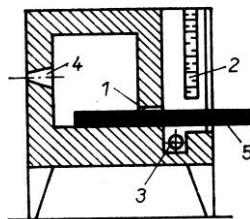

Fig. 2. Scheme of slot chamber furnace: 1 – longitudinal slot; 2 – water screen; 3 – air shower; 4 – burner; 5 – heated semi-product

4.1.3. Chamber movable-bottom furnaces

They are used forges for open die forging. They are used for heating ingots and rough forgings. The furnace in the Figure 3 has got the hearth in the form of a robust, refractory lined protected truck that moves on rollers thanks to a simple mechanism.

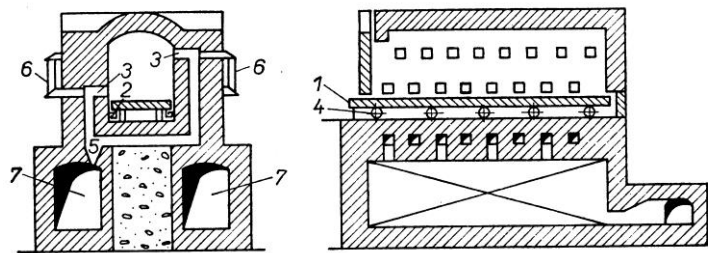

Fig. 3. Scheme of a chamber movable-bottom furnace
 1 – movable hearth; 2 – hearth sealing; 3 - burners; 4 - rollers; 5 – channel for alternate supply of air to burners and combustion products to regenerators; 6 – gas supply; 7 – chambers of regenerator

4.2 Electric heating

The fastest way to heat semi-products of a smaller thickness for drop forging applications being characterized by the following advantages:

- low scale generation (0.4 to 0.6%) that which favourably affects tools life and material balance
- precise observance of the top forging temperature,
- Easy mechanization and automation of movement of semi-products during heating including simple link up to working cycle of a forming machine

- Significant improvement of working conditions and working and living environment.

- **4.2.1 Resistance heating**

If the electric current passes through metallic material, the moving electrons collide with atoms of metal and transmit them part of their kinetic energy. The resulting oscillations of atoms causes the temperature rise of a metal material, the semi-finished product destined for forging.

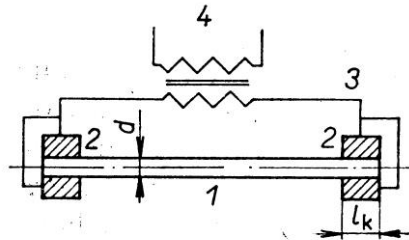

Fig.4. Scheme of resistance heating

1 – heated of semi-product; 2 - contact; 3 – conductor; 4 - transformer

The semi-product is placed between two contacts 2, connected by a conductor – 3 with the secondary winding of the transformer 4th. The contacts must act on the semi-product in the length of $l_k > 0.5 d$. Because the semi-product is not insulated during heating, the heating must be realized in a short time to avoid huge heat loss and excessive scale generation. Therefore, it is necessary to deliver an intensive current of to the semi-product.

$$I = \sqrt{Q/(R \cdot \tau)} \quad (4.1)$$

where I it is current intensity [A]

Q it is a quantity of heat for heating of a semi-product without any loss [J],

R it is a resistance [Ω],

τ it is the time of heating [s].

For substitution into the equation (4.1) there can be used the following relation:

$$R = \rho \cdot \frac{l}{S} \quad (4.2)$$

Where ρ is a specific resistance (Ω m),

l – it is a length of a heated body (m),

S – it is a cross sectional area (m^2).

After substituting we can get for heated bodies of circular cross section the following relation:

$$I = 0,886 \sqrt{\Omega \cdot d^2 / (\tau \rho l)} \quad (4.3)$$

The intensity of current mainly depends on the diameter d of the heated body. It is recommended it would be $d < 70$ mm. Great influence on specific consumption of electricity and heating efficiency has got the ratio l/d^2 . If $l/d^2 > 1$ has been reached, the specific electricity consumption for heating and the heating efficiency are optimum. In forges the AC power supply frequency with the voltage of $U = 2$ to 22 V and electric current $I = 5-10$ kA.T are used

$$\tau = \frac{mc(t_k - t_o)}{a} \quad (4.4)$$

where τ it is the heating time [s]

m it is the weight of a heated body with length of 100 mm [kg],

c it is a specific thermal capacity [$\text{kJ kg}^{-1} \text{K}^{-1}$],

t_o, t_k these are initial a finishing temperature of a heated body [$^{\circ}\text{C}$],

a it is a coefficient of the heating intensity ($a = 0.95$ to 1.43 kJ s^{-1}).

Electric resistance heating is used in the drop forging, the heater is directly built in the working area of the forming machine. With a suitable arrangement of contacts it is possible to heat only one determined section or several sections of the semi-product.

4.2.2 Induction heating

If alternating electric current passes through a conductor, a magnetic field is creating around it that changes its magnitude and direction. If a metal body is inserted in the magnetic field, there is induced an electromotive force due to action of which the electric current will pass through the body and the body will start to heat itself. And on this principle the quickest way of heating – the induction heating (Fig. 5) - is based. From the conductor 2 (a copper pipe through which cooling water flows) there is made a spiral as a basis of inductor in which a semi-product 1 destined for heating is inserted. As a source of electric current there is a high frequency generator. The induced eddy currents do not penetrate uniformly through a heated semi-product: the current density decreases towards the core of the semi-product according to the relation (4.5).

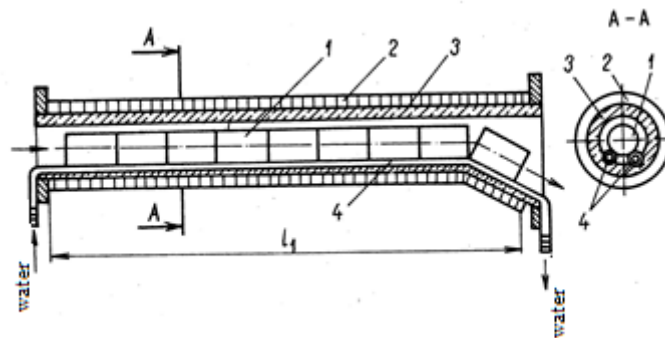

Fig. 5. Scheme of induction heating
1 – heated semi-product; 2 - inductor; 3 lining; 4 – guides

$$J_x = J_o \cdot \exp(-\alpha x) \quad (4.5)$$

where J_x it is a current density in the distance “x” from the body surface [Am^{-2}]

J_o it is a current density on the body surface [Am^{-2}],

x it is a distance from the surface to the body core [m],

α it is a dimensionless coefficient. The coefficient shall be determined from the following relation:

$$\alpha = 0,1987 \sqrt{\frac{f \mu_r}{\rho}}$$

Where f is a frequency (Hz), μ_r it is a relative permeability, ρ it is a specific resistance [$\Omega \cdot \text{m}$].

For $x = 1/\alpha$ there is valid that $J_x/J_0 = 1/e = 0.368$, which means that the current density has decreased at that distance to 36.8%. This distance is called the depth of penetration and it is marked with the symbol δ . In the depth δ the largest part of current is flowing through from the given power input and the greatest heat is developing there. For calculation of the depth δ there is used the following relation:

$$\delta = 5,03 \sqrt{\frac{\rho}{f \mu_r}} \quad (4.6)$$

With knowledge of the depth of penetration the optimal cross-sectional area of the heated body can be determined. For a semi-product of circular cross section, the optimum diameter shall be calculated from the following relation:

$$d = (4 \text{ až } 10)\delta \quad (4.7)$$

About efficiency and effectiveness of induction heating the choice of frequency is determined to a large extent. Unlike the resistance heating it is possible to use induction heating for semi-products of various cross-sections and of the shortest lengths. The disadvantages of induction heating are high acquisition costs, high power consumption (0.4 to 0.5 kW.h.kg-1) and the need to replace the inductor when changing the cross-sectional dimensions of the heated semi-product.

4.3. Speed heating

During heating of thin semi-products in a furnace heated to a high temperature (1,400 to 1,500 °C) it is reached a significant increase in the rate of heating without any risks of large thermal stresses. At the high temperature of a furnace there heat interchange by radiation prevails, which accelerates the heating to the extent that it is approaching the speed of induction heating. Through the outlining procedure there can be reached a significant increase in output capacity of heating furnaces while reducing burn-off and an almost complete restriction of decarburization. Speed-heated steel is finer-grained and has increased formability.

4.4. Heating in controlled atmosphere

It is used to heating smaller semi-products destined for drop forging, in the case of the more stringent demands on surface quality and dimensional precision of forgings. The controlled environments are usually gaseous (atmosphere) and liquid (molten glass and salts).

4.5. Forging cooling

Most of the forged pieces are cooled in air after forging; cooling time is calculated as follows:

$$\tau = 0.006 \Delta T \cdot d \text{ [s]} \quad (4.8)$$

where ΔT is the temperature difference over the cross section of the forging (K) d - diameter of the forging (m).

With some selected forgings it is necessary according to the size of the cross section and the contents of additive elements to ensure a slow cooling to achieve the required mechanical

properties, to prevent creation of surface and internal cracks and release the residual stresses. It is most preferred to combine cooling with the heat treatment, which will improve further the properties of the forging.

Cooling of forgings is uneven, which leads to creation of thermal stresses, the magnitude and direction of which can vary during cooling. In the first stage of cooling the surface layers are cooled down more rapidly, and thus they shrink more than it would correspond to a mean temperature of forging so that on the surfaces some tensile thermal stresses appear, as well as some pressure thermal stresses at the axis of a forging. In the final stage of cooling the situation is opposite: the surface layer with a lower temperature shrink lesser than it would correspond to the mean temperature of the forging so that they are under the influence of pressure thermal stresses, and their axial portion is exposed to the tensile stresses which are particularly dangerous at a temperature lower than 550° C.

Analysis of an origin and a change of the sign of heat stress are valid in full for low carbon and low-alloy steels. When cooling hypereutectoid and higher-alloyed steels, however, the tensile stress in the surface layer of the forging are reduced insignificantly, in consequence of a limited relaxation ability of these steels. In this case, the change of thermal expansion sign is nearly improbable. Rather, it is to be expected that under the influence of tensile stress even microscopic surface cracks spread enough to degrade a forging completely.

With the steels having a modulus of tensile elasticity $E = 200$ GPA and a thermal length expansion $\alpha = 12 \times 10^{-6} \text{ K}^{-1}$ it is considered that with one-sided cooling of a body from the finishing temperature of 850 ° C thermal stresses may occur up to 250 MPA for every 100 K of temperature difference between the surface and the axis of the forging.

Besides thermal stresses also re-crystallization and residual stresses may arise during cooling of forgings. If a stress in its total exceeds a cohesive strength at a certain spot of the body, cohesive failure occurs. With steels hardenable in air cracks may occur even during storage of cold semi-products, especially due to some ambient effects, as are impact, vibration or the local temperature changes, e.g. during grinding.

In order to reduce internal stresses, the cooling rate of forgings shall be reduced using one of the following methods of cooling: in piles in an open air, in metal boxes or pits, in insulating fillings and in furnaces.

Forgings made of carbon steels can be cooled in the air, provided that the diameter d and the carbon content satisfy the following conditions:

$d < 200 \text{ mm} \dots\dots\dots C < 0.45 \%$

$d = 200 \text{ to } 600 \text{ mm} \dots\dots C < 0.40 \%$

$d > 600 \text{ mm} \dots\dots\dots C < 0.30 \%$

For forgings of alloy steels the cooling procedure is recommended consisting of successive steps:

1. the lag at the temperatures from 650 to 700 °C within the time of $\tau = d/25 \text{ h}$,
2. cooling in a furnace at rates from 10 to 12 K h^{-1} up to the temperature $t = 200 \text{ °C}$,
3. cooling in an open air.

A special case of internal defects that arise during cooling of forgings are flakes.

4.5.1 Flakes

These are cracks which affect the internal parts of some of cooled forgings. The cause of the flakes is simultaneous affecting of two factors: the concentration of hydrogen in the steel and internal stresses in the forging. The emergence of flakes explains the mechanism of a delayed fracture that is developed after a certain incubation time, under the influence of a voltage that is lower and does not correspond to the tensile strength.

With the temperature drop the solubility of hydrogen in the steel reduces significantly, so atomic hydrogen migrates to disturbance fields, that is, according to the kinetics from the 3S to vacancies, and from the 3S to dislocations. Around dislocations the hydrogen of Cottrell's atmosphere creates and further motions through dislocations are slowed down, which may reduce breaking stress, which can occur only when there is the minimum concentration of hydrogen, which is reported as $2 \text{ cm}^3 / 100 \text{ g steel}$.

It can not be overlooked that there is an interdependence between the hydrogen concentration and internal stresses to the effect that by a reduction of internal stresses (e.g. from Q_m to the Q_z) flakes will occur only at a higher hydrogen concentration. On the contrary flakes may occur even at a low, but always at the supercritical hydrogen concentration, but assuming the occurrence of high internal stresses.

The fact that the flakes do not affect the casting structure can be explained by the fact that there is a large number of defects of critical size, in which the hydrogen is captured in its molecular state, so it does not reduce the resistance to breaking.

The predisposition of steel to create flakes depends on those factors by which it is possible to influence concentration of hydrogen in the steel and the size of the internal stresses in a cooled forging. These include:

1. chemical composition of steels (more prone are steels with high carbon content and alloy steels),
2. steel structure (flakes are found only in steels, which changes their structure during cooling, which causes a re-crystallization stress),
3. size and shape complexity of a forging (the larger and more complex in the shape a forging is, the stronger are the stresses),
4. rate of a forging cooling (the larger is the cooling rate, the larger are stresses),
5. austenite stability (the more stable is austenite, the more easily the flakes are created),
6. method of steel producing (vacuum-treated steel has a lower concentration of hydrogen).

Creation of flakes can be prevented by anti-flake annealing, which is connected directly to the finishing temperature. With steels having unstable austenite, the forging is cooled to the temperature of a pearlitic transformation, resulting in austenite disintegration thereby in reduction of solubility of hydrogen in steel. At the same temperature diffusion annealing is then carried out. With steels with a stable austenite, the forgings are cooled to a temperature of bainitic transformation (pearlitic transformation is characterized by a long incubation period), and then they are heated to a temperature just below A_{c1} , when the diffusion annealing is realized, whose duration depends on the size of the forging and the hydrogen concentration in the steel.

4.6. Division of steels into groups of heating

In forge plants it is not possible to heat separately in one furnace steel of a different quality, so the steels were divided into four basic groups of heating with the prototypic - sample heating modes. For each group of heating there were selected properties of steels:

1st group

Steels with the highest thermal conductivity and the lowest thermal expansion. The structure of the steel after quenching in an open air is ferrite-pearlite. These include carbon steels ($C \leq 0.55\%$), low alloy steels with low carbon content ($C \leq 0.2\%$) and with an addition of Cr, Mo and W up to 1% of each additive element.

2nd group

Steels with reduced thermal conductivity and increased thermal expansion. The structure of the steel after quenching in an open air consists of ferrite, pearlite and bainite. The group includes high-carbon steels ($C \leq 0.9\%$), low alloy steels with a medium carbon content ($C \leq 0.9\%$), low alloy steels with a medium carbon content ($C \leq 0.6\%$) and with an addition of Mn, Cr, Mo and W, then the low alloy steels having a carbon content of 0.4% and an addition of Ni and higher-alloyed steels with carbon content up to 0.2% and an addition of Ni.

4.7. Accompanying phenomena of heating

4.7.1 Burn-off

Burn-off comes to being due to surface oxidation of a heated body in the furnace atmosphere. The emergence of forge scale is due to double sided diffusion reaction of iron and oxygen, while the decision there is the diffusion of iron. As a consequence of its high affinity to oxygen some oxides occur in the order (from the parent metal towards the atmosphere): FeO, Fe₃O₄ and Fe₂O₃, and their proportion varies depending on the temperature. Oxidation is realized due to action of free oxygen, CO₂ and water vapour and it further accelerates due to continuous sloughing of scale from the surface of the heated body as a consequence of different thermal expansion of the scale and the parent metal. The scale can contain 71 to 76% of iron, and their density ρ is around 3,900 to 4,000 kgm⁻³.

The burn-off has negative consequences:

1. Metal loss (2-3% per one heating, wherein 4% of manufactured steel is destroyed due to the scale acting),
2. Reduction of the service life of the furnace hearth, on which the scale loose slag can be created which can even react with lining,
3. Extension of operations of the scale removing descaling before starting forming process,
4. Reduction of the lifetime of forming tools,
5. Increased risk of scrap rate in the form of scales being pushed into the surface of formed semi-products,
6. The necessity of scale removing from some semi-products before successive cold forming or machining (drop forgings).

The amount of generated scale depends on the following factors:

1. The heating temperature. It manifests itself most strongly. The scale can be created from the temperature of 600 to 700 ° C; initially almost imperceptibly, but above the temperature of 1000 ° C very intensively.
2. The rate of oxidation at 1300 ° C is seven times higher than at the temperature of 900 ° C, above the temperature of 1320 ° scale is starting to melt. At temperatures of 600 to 1,200 ° C the scale generation of carbon steels can be calculated as follows:

$$z = 48,8\sqrt{\tau} \cdot \exp(-9000/T) \text{ [g cm}^{-2}\text{]} \quad (4.9)$$

where τ it is the heating time [h].

3. Heating time. It acts according to the equation (5) by a parabolic dependence, which means that the growth of scale slows down in some time.

4. Furnace atmosphere. According to the presence individual components it can be oxidizing (O_2 , CO_2 , H_2O , SO_2), reducing (H_2 , CH_4 , C_2H_2) and neutral (N_2). Oxidizing atmosphere largely prevails with the biggest oxidizing effect of SO_2 , CO_2 and H_2O . Scale of the oxidizing atmosphere is easily peeled off from the basic material, which is caused by a distinct boundary between the scale and the basic / parent metal. In the reducing or neutral atmosphere they layer of scale is substantially thinner but firmly adhering which grow through along grain boundaries into the basic / parent metal, so that their removal is much more difficult.

4. Chemical composition. With carbon steels having carbon content to 0.3% scale generation increases. At higher carbon content scale generation decreases, because there CO_2 results from carbon oxidation, which restricts further creation of scale. Additive elements which are characterized by higher affinity with iron (Cr, Al, etc.) they form a continuous layer of firmly adhering scale, which also slows down further oxidation. Additive elements, with a lower affinity with iron (Ni, Cu, Mo, etc.), are deoxidated beneath the surface of scale, thereby they do not slow down the oxidation of the surface layers.

As another factor that shall be considered there is the surface area of a heated body, that is the surface area to volume ratio (the greater is the superficiality, the smaller scale generation due to the heating time shortening), and the method of handling semi-products in a furnace where any movement of the semi-products along the hearth initiates scale loosening, while a new layer of scale is created on the exposed surface.

4.7.2 Decarburization

Decarburization depletes the surface layer of a heated semi-product of carbon, which results in reduced strength and often even to a distortion / warping so affected part or in creation of hardening cracks. Especially adversely it manifests itself in cyclically loaded parts such as springs and tools. Decarbonized layers at a certain load are deformed plastically, while remaining material flexibly, which after some time leads to creation of surface cracks.

The steel is decarburized due to acting CO_2 and H_2O (particularly), and H_2 and O_2 (to a lesser extent). The decarburized layer with its thickness not exceeding 2 mm appears under scale. At high temperatures, the oxidation rate is greater than the rate of decarburization, so the decarburization is hardly noticeable under a thicker layer of scale. At lower temperatures, on the contrary decarburization predominates over oxidation.

The lower is the carbon content, the higher is a relative decarburization. With high-carbon steels, the loss of carbon in the surface layer equals to the diffusion of the basic metal due to a greater concentration gradient. Decarburization is supported by additive elements initiating activity of carbon in austenite (Si, W, Mo), chromium is acting oppositely.

4.7.3 Overheating and burning-down

Overheating occurs when heating the steel just above the top forming temperature where austenite grain becomes coarse. Due to its recrystallization after subsequent cooling there occurs a characteristic needle-like structure whose unfavourable characteristics can be corrected by normalized annealing. This first stage of overheating can be determined as an overheating without affecting the grain boundaries.

The second stage, overheating with affecting the grain boundaries, leaves in the steel permanent consequences.

It is caused by sulphur (FeS , MnS), which melts due to the solidus temperature and diffuses in the steel on boundaries of the austenite coarsened grain which is characterized by a lower

surface energy. During subsequent cooling, the sulphur is deposited on the borders of the austenite grains in the form of sulphides, but at increased concentration levels. Sulphides then penetrate through ferritic network and weaken its cohesion, thereby reducing the plastic properties of steel, especially the notch impact toughness.

To overheating with irremovable influence of grain boundaries there are susceptible especially steels of a lower content of manganese in which sulphur is bounded to low-melting sulphide FeS, and as far as other alloy steels are concerned, these are steels with an addition of nickel.

If during heating the solidus temperature was exceeded inadvertently, even locally, incineration of steel may happen, which means its depreciation in the form of complete cohesive failure. Steel sometimes literally falls apart into individual grains due to the melting of their borders, where in addition to the previously dissolved sulphur the phosphorus begins to dissolve from inside of grains.

Questions:

1. What types of gas fired heating furnaces are used in forges?
2. How to calculate the heating time for resistance heating?
3. How to calculate the depth of penetration for an induction heating and what purpose it can be used for?
4. Can you calculate the cooling time from the lower forging temperature for hypo-eutectoid steels?

Tasks to solve:

1. Compare the heating speed in a gas fired furnace, a chamber furnace and the heating speed in electric induction furnaces.

5. LEVEL OF THROUGH-FORGING AND BASIC FORGING OPERATIONS

Chapter contents:

- Initial semi-products
- Forging ingots
- Level of through-forging
- Basic forging operations
- Upsetting
- Punching



Time needed for studying: 120 minutes

Aim: After studying this chapter

- You will be able to analyse forging ingots
- You will be able to calculate the level of through-forging
- You will acquaint with basic operations of open die forging



Explication

5.1 Initial semi-products

Initial semi-products may have a structure in the as-cast state (forging ingots, continuously cast semi-products) or a formed structure (cast blocks and billets rolled, rolled sections of square and round cross sections).

5.1.1 Forging ingots

Forging ingots are pre-products for medium and large forgings. Their weight is up to 570 t, and they are cast of killed steel. The shape of a forging ingot is shown in Figure 5.1 With large ingots there are octagonal to 24-angle steel cross sections with concave sides and rounded corners. Ingots of a smaller weight (up to 1 t) tend to have a circular cross-section. Ingot top and bottom form 15 to 24%, respectively, 3 to 4% of the total weight of the ingot. To produce a forging there is a need to have usable metal in the form of so-called utility weight of an ingot m_{uz} :

$$0,9m_t \geq m_{uz} = 0,9m_t^a - p \cdot 0,04m_t \quad (5.1)$$

where m_t it is weight of the ingot body (kg);

a – it is an indicator of the ingot structural perfection ($a = 0.988$ to 0.995);

p – it is upsetting indicator ; $p = 0$ for an ingot without upsetting operation, $p = 1$ for upsetting ingot.

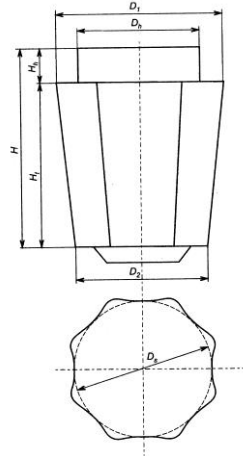

Fig. 5.1. Shape of forging ingot

Forging ingots are characterized by chemical and physical heterogeneity, internal imperfections of different origin (shrink holes, pores, shrinkage porosity,, bubbles), and other defects.

The characteristic features of standard ingots are: slenderness (h_t / d_s) and body draught (k_t).

In addition to the ingot shapes mentioned above there are used ingots : with bigger body draught ($U = 10$ to 12%) with a bigger body slenderness ($h_t / d_s = 3$ to 5), with a smaller slenderness of the body ($h_t / d = 0.7$ to 1.3) and hollow ingots. The advantages of these ingots include the increased utilization of steel, lower level through-forging. Except these structural changes, the quality of forging ingots has been increased: steel ladle refining, vacuum processing of steel, electroslag remelting, and casting ingots gradually from several heats with deliberately stepped content of segregating elements.

5.2 Grade of through-forging

With forging ingots casting structure is gradually disrupted, dendrites are crumbling and together with non-metallic inclusions and segregations they are pulled in the direction of the main deformation. There is a characteristic strandedness, whose orientation can be influenced by forging. At the same time internal imperfections are closed and welded, thereby increasing the density and improving the plastic properties of the steel. High forging temperature accelerates the diffusion process. Forging can influence the grain size and thus the resultant mechanical properties of the forgings. Influence of forging on mechanical properties of the initial casting structure is assessed with the aid of a contractual quantity, the grade of through-forging (PK).

5.2.1 Calculation of the grade of through-forging for longitudinal forgings

For forgings where the final forging operation is the lengthening the grade of through-forging can be calculated as follows:

$$PK = A^n P^n K \quad (5.2)$$

where A it is an upsetting equivalent, $A = 0.7$ to 0.9 ,

$$P - \text{the grade of ingot upsetting, } P = \frac{S_p}{S_i}$$

$$K - \text{the grade of ingot lengthening, } K = \frac{S_i}{S_v}$$

n – number of upsetting operations,

where S_p it is a cross section of upset ingot,

S_i it is the surface area of the ingot middle cross section,

S_v it is the surface area of the largest forging cross section.

For forgings of discs and circular plates where the last operation is upsetting, and for longitudinal forgings the cross section of which is larger than the ingot cross section the following relation can be used for calculation of the through-forging grade:

$$PK_2 = PK_1 \sqrt{P'} \quad (5.3)$$

where PK_1 it is the grade of block through-forging according to

$$P' - \text{the grade of upsetting in the last upsetting operation, } P' = \frac{S_{vp}}{S_s}$$

Where S_{vp} it is a cross section of an upset forging, S_s it is a cross section of the block.

If after upsetting even lengthening shall be carried out as for longitudinal forgings, and if there the relation $K < 1$ is valid, the lengthening is not included into the relation (5.3). For the calculation of through-forging for forgings of hollow bodies being lengthened on a mandrel the following relation is valid:

$$PK_3 = PK_2 K' \quad (5.4)$$

where PK_2 it is a grade of through-forging of upset disc

K' – the grade of lengthening on the mandrel, $K' = \frac{t_{kt}}{t_{dt}}$

where t_{kt} it is the thickness of a punched disc side,
 t_{dt} it is the thickness of a forging of hollow body.

For the forgings of discs being flattened on a mandrel the grade of through-forging can be calculated as follows:

$$PK_4 = PK_3 K'' \quad (5.5)$$

where K'' it is a grade of flattening on a mandrel, $K'' = \frac{S_{kt}}{S_{kr}}$

where S_{kt} it is a cross section of a punched disc,
 S_{kr} it is a section of a disc forging.

The grade of through-forging is chosen in such a manner to achieve the forging desired properties. For ingots manufactured with conventional technology the following relation can be used:

$$PK = 3 \quad (5.6)$$

The lower is the concentration of additive elements in the steel and the more improved is a structure of the ingot the lower can be the grade of through-forging.

For calculation of the grade of through-forging in dependence of the ingot body weight it is possible to use the following relation:

$$PK = 2.5m_t^{0,0764} \quad (5.7)$$

5.3 Basic forging operations

The production procedure of open die forging consists of many separate forging operations. Upsetting and lengthening significantly affects the metallurgical and technological aspects of forging, the remaining operations can only influence the technology of forging.

5.3.1 Upsetting

Upsetting is the most demanding forging operation as for the force and energy. When upsetting, the height is reduced and a cross-section of the body is increased. The purpose of upsetting is to increase the grade of through-forging, to reduce the anisotropy of mechanical properties, to achieve the radial grain, and to produce forgings with a larger cross section than corresponds to the initial semi-product and get rough forgings suitable for subsequent punching or lengthening.

Basic features of upsetting:

- a) The entire volume of the body is exposed to tools acting
- b) The tension caused by an external power and force source acts exclusively on the contact surfaces between the tools and the upset body,
- c) No tension acts on the side walls of the upset body,
- d) The deformation is unevenness.

The result of uneven deformation is the creation of additional tensile stresses on the side surface of the upset body, undesirable shape change of the side walls of the forging in the form of barrel shape, difficult through-forming certain areas of the forging, non-uniformity of the resulting structure and the mechanical properties. Especially significant consequences of irregular deformation appear in the forged discs and plates of small thickness and large diameter. Barrel Distortion can be calculated from the relation (5.7) and when upsetting it varies depending on the relative reduction/removal rate in height and slenderness of the initial semi-product, according to the Fig. 5. 2.

$$S = \frac{V_s}{V_c} \cdot 100 \tag{5.8}$$

where S it is the barrel distortion [%].

V_s it is the volume of the forging barrel-shaped part [m³]

V_c it is the forging volume

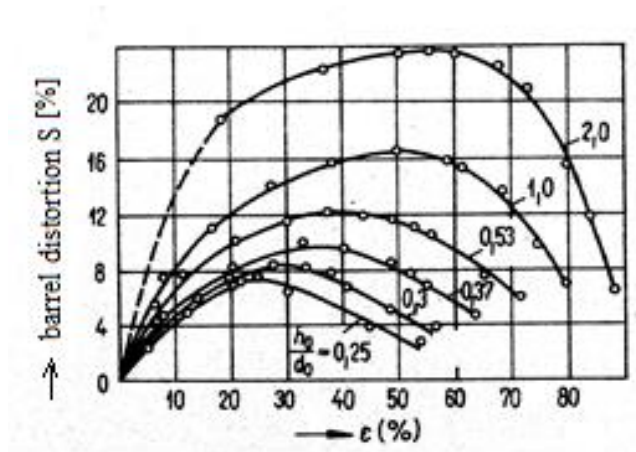

Fig. 5.2. Dependence of barrel distortion S on a relative reduction/removal rate in height ϵ and the slenderness of an initial semi-product h_0/d_0

To reduce uneven deformation there is used an initial semi-product of a lesser slenderness which is upset with a great reduction/removal rate in height, the barrel distortion can be reduced by reduction of friction forces on the contact area of a tool and the body being upset. The depth of penetration of a strong plastic deformation when upsetting the cylindrical body is of dimensions d and h (Fig. 5.3) defined by two cones on the common base d and heights $1/3d$ and $3/4d$.

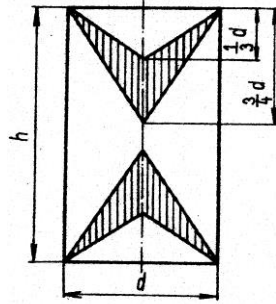

Fig. 5.3. Depth of penetration of a strong plastic deformation

To achieve the optimum shape of an upset semi-product it is recommended to observe basic rules of upsetting:

1. Uniform through-warming of an initial semi-product up to the top forging temperature
2. Perpendicular front surfaces,
3. Slenderness of an initial semi-product to $h/d < 2,5$
4. When upsetting on a hammer it is to reduce the height of an initial semi-product to three quarters of the working stroke of the ram,
5. Before an ingot upsetting it is necessary to forge the handling pin out of its top,
6. For ingots it is recommended to choose the grade of upsetting of $P > 2,8$,
7. Before upsetting re-forg the ingot edges of low-formable steels.

Basic methods of upsetting:

1. Flat upsetting plates (Fig. 5.4a) are used for upsetting smaller semi-products destined for discs or plates.
2. Shaped upsetting plates (Fig.5.4b) are used for upsetting ingots destined for further lengthening.
3. In simple fixtures /jigs (Fig.5.4c) there is carried out a local upsetting of flanged discs with one or two end stepping that cannot be forged by stepping due to their small height.

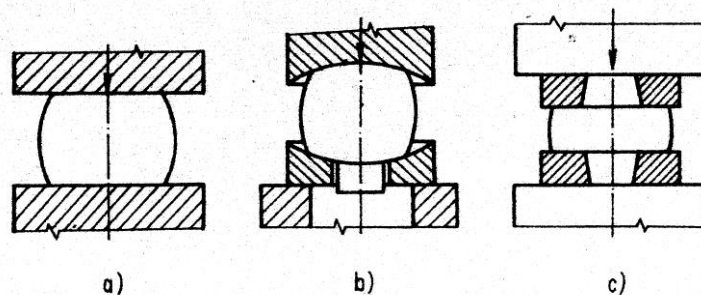

Fig. 5.4. Basic methods of upsetting

For forgings of discs and plates of large diameter and small thickness there are used flattening after upsetting, see Fig. 5.5. Barrel Distortion of upset forgings shall be removed by working /trueing by forging and levelling the faces

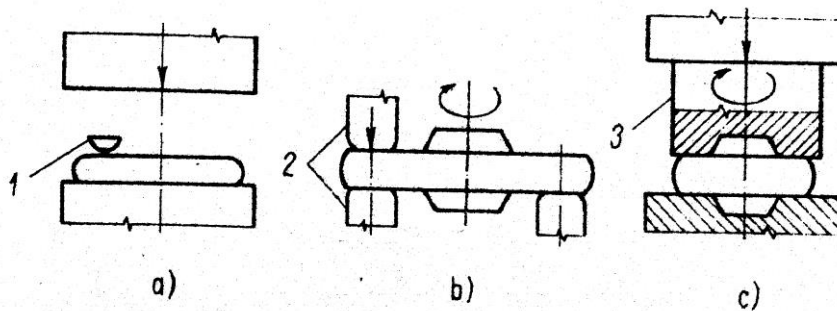

Fig. 5.5. Basic methods of through-forging
 a) by a levelling gib 1, b) by even anvils 2, c) by narrow shaped anvil 3

Choosing a forming machine for upsetting

Deformation force / strength acting during upsetting on a hydraulic press can be calculated on the basis of the following relation:

$$F = \psi \sigma_p \left(1 + 0,17 \frac{d}{h} \right) S_{vp} \quad (5.9)$$

Where F – it is deformation force / strength (MN),

Ψ – it is a correction factor,

σ_p – it is a natural resistance to deformation (MPa),

d, h – it is a mean diameter and height of upset forging (m),

S_{vr} – it is a cross-section of upset forging (m^2).

Weight of the ram when upsetting on the power hammer:

$$m_b = 1,7 \cdot 10^5 \left(1 + 0,17 \frac{d}{h} \right) \sigma_p \varepsilon V_v \quad (5.10)$$

where m_b – it is the ram weight (kg)

ε – it is a relative removal/removal rate in height at the last blow; $\varepsilon = 0.025$ (small forgings) up to 0.06 (large forgings),

V_v – it is a forging volume (m^3).

5.3.2 Punching

By punching it is possible to obtain a forging with either open/through hole or with a blind hole (Fig. 5.6). The basic rules for punching:

1. Uniform warming up of an initial semi-product,
2. The initial semi-product re-forging to a disc of the height h and of the diameter d ($h < 0,8d$).

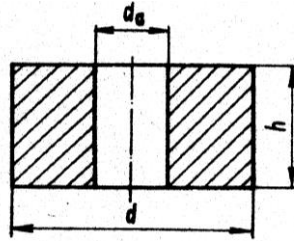

Fig. 5.6. Punched forging

The main methods of punching are given in the Figs. 5.7 ton 5.10 and the scope of their using can be found out in the Table 5.1.

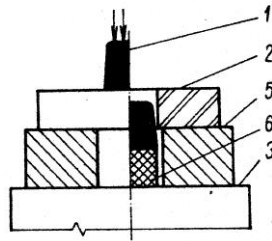

Fig. 5.7. Shearing punching by a solid mandrel

7 – shearing mandrel; 2 – sheared semi-product; 3 – bottom anvil or upsetting plate;
4 - adapter; S – punching ring; 6 – punching body flash

The inner diameter of forging d_a is limited as follows:

$$0,4h \leq d_a \leq \frac{d}{3} \quad (5.11)$$

Discs being forged from ingots shall be placed on the lower tool with their part under their top to force less quality metal from this part of the ingot to the punching body flash.

The weight of the punching body flash shall be calculated as follows:

$$m_{vd} = kd_a^2 h \quad (5.12)$$

where m_{vd} it is the weight of punching body flash (kg)

k it is a correction factor involving the method of punching and density of metal,

d_a it is an inner diameter of forging (m), h – forging height (m).

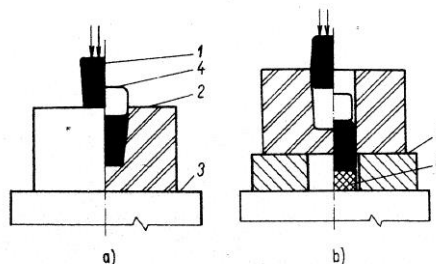

Fig. 5.8. One-sided punching using a solid mandrel
a) mandrel pushing-down, b) cutting the punching body flash

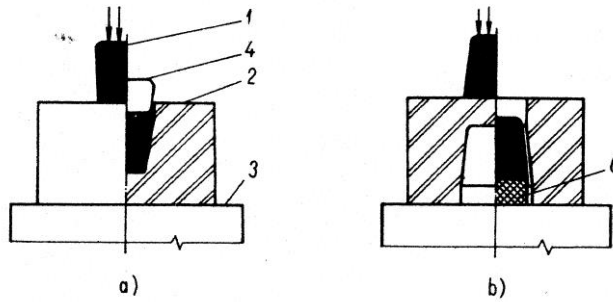

Fig. 5.9. Double-sided punching using a solid mandrel
 a) mandrel pushing-down, b) cutting the punching body flash

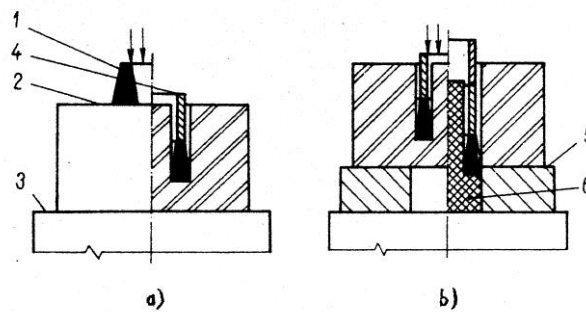

Fig. 5.10. Punching by a hollow mandrel
 a) mandrel pushing-down, b) cutting the punching body flash

Table 5. 1. Basic methods of punching

Methods of punching	Piercing mandrel			Mandrel hollow
	combined	single	double	
Extent h/d	$h/d < 0,13$	$h/d \geq 0,13$ $h/d \leq 0,4$	$h/d > 0,4 d$	$d_a > 300 \text{ mm}$
Ratio k	5,55	1,54	1,85	6,8 až 7,1

5.3.3 Lengthening

The lengthening decreases deliberately the cross section of a semi-product, while its length increases. In forges the lengthening operation takes 75% of the production time. It is used as a preparatory and finishing operation at forging rods, plain, stepped and necked shafts, crankshafts, etc. The lengthening is a discontinuous forming procedure which is carried out through gradual compression of partial volumes of a formed body (Figure 5.11) with its simultaneous shifting and chamfering. This procedure together with the periodicity of bites may facilitate the growth of shearing deformation, thereby breaking-up the dendritic structure. This results in an improvement of mechanical properties at comparable forming procedures, such as rolling.

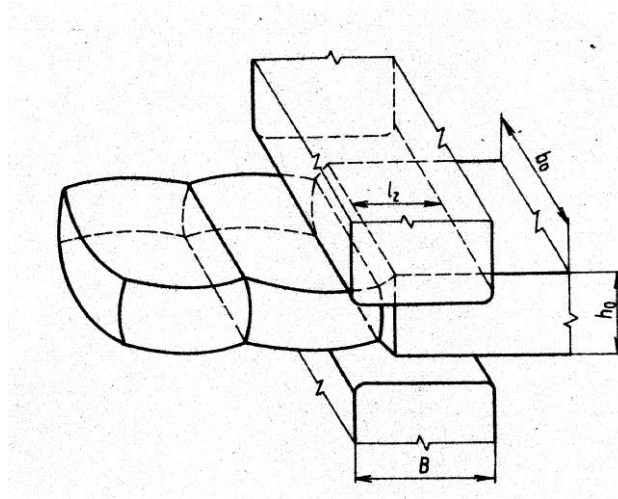

Fig. 5.11. Lengthening on flat plain anvils

There is a quantity that can influence the qualitative aspect of lengthening especially in forging ingots - the relative length of a bite l_z/h_0 . It decides about deformation penetration effect as for the depth of deformation zone, and thus about the state of stress and uneven deformation in this area, which influences the final quality of the forging. The most favourable conditions for perfect through-forming of the on-axis part of the lengthened semi-products by compressive stress can be achieved if:

$$0,7 \geq \frac{l_z}{h_0} \geq 0,5 \quad (5.13)$$

where l_z it is the length of a bite [m]

h_0 it is a je thickness (height) of a body being lengthened [m]

At $LM / h_0 < 0.5$ additional tensile stresses occur in the axis of a forging being lengthened which may endanger its integrity, particularly in steels of low formability.

5.3.3.1 Ground rules of lengthening

Besides the initial ingot lengthening using only small removals /draughts ($\varepsilon_h \leq 15\%$), there can be chosen also removals /draughts of $\varepsilon \geq 20\%$ per bite according to the formability of steel. At the final bite a critical grain growth must be avoided. Size removal /draught is limited by so-called cross-sectional indicator φ :

$$\varphi = \frac{b}{h} \leq 2,5 \quad (5.14)$$

where b, h they are the width and height of the cross section of a lengthened semi-product. For steels of high formability the following relation is valid:

$$\varepsilon = \frac{1 - b_k}{\varphi h_o} \quad (5.15)$$

where b_k it is the final width of a forging, [m]
 h_o – it is an initial height of a semi-product, [m]
 φ - it is a cross-sectional indicator.

Width of anvils B is chosen with regard to the initial height of a semi-product a final width h_o of a forging b_k :

$$1,5b_k \geq B = (0,5 \text{ až } 0,6)h_o \quad (5.16)$$

To achieve a smooth surface of a forging without laps, the length of the bite depends on the width of the anvil B and on the absolute draught removal ε_h :

$$\frac{\Delta h}{2} \leq l_z = (0,4 \text{ až } 0,8)B \quad (5.17)$$

To uniform the deformation it is recommended to lengthen with offsetting the borders of the zone of deformation, i.e. overlapping of bites in each subsequent pass.

Angle of chamfering of ω which has a significant impact on the lengthening procedure, is chosen in the range of forgings of:

Rectangular section $\omega = 90^\circ$,
 Circular section $\omega = 60$ to 75° .

5.3.3.2 Basic methods of lengthening

Lengthening forgings of rectangular section on the flat plain anvils with a square-rectangle-square shape change. By this favourable shape of the zone of deformation, thanks to its large contact surface (Fig. 5.12a) can be secured penetration of the deformation effect even to the axis of the body being lengthened.

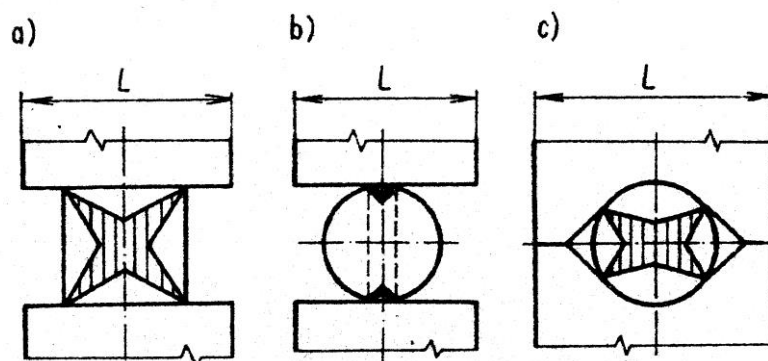

Fig. 5.12. Shape of the zone of deformation at lengthening of forging
 a) of rectangular section on flat plain anvils, b) of circular section on flat plain anvils, c) of circular section on the shaped anvils

Lengthening of forgings having an circular section on flat plain anvils faces the negative shape of a deformation zone (Fig.5.12b). It is recommended to lengthen initially according to the “square-rectangle-square” shape change, and only at the moment of gaining an approximate equality of the square side and the final diameter of the forging, further re-forging is done to octagonal and circular cross sections. In addition to these methods there is used lengthening of forgings of round section on the shaped or combined anvils (Fig. 5.12c). This method may take advantage of a larger contact area, which has a positive impact on the state of stress, reduction of spreading, and increase the perfection of shape and surface quality of the forging. The increase in productivity of forging by about 20-40% compared to flat plain anvils is not also negligible.

Large ingots can be lengthened with their surfaces being cooled purposely. After the cross-section completion a great deformation gradient with a strong compressive stress in the axis of the ingot is created, thus accelerating the conclusion of internal discontinuities and that is why it is possible to reduce the grade of through-forging by one third. The procedure is as follows. The ingot heated to the upper forging temperature is cooled down so that the temperature gradient between its axis and the surface would be 250 to 350 ° C between the axis and the surface. The following procedure is lengthening on the anvils with relative proportional reduction/removal rate of 7% (Figure 5.13). This operation is followed by usual lengthening.

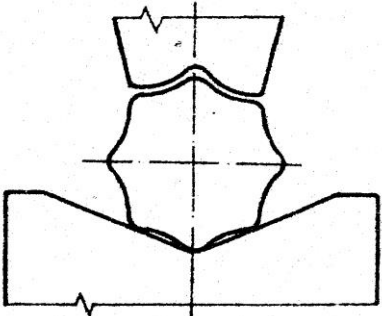

Fig. 5.13. Anvils for lengthening of ingots with purposely cooled surfaces

When lengthening on a flat plain anvils dimensional changes of a semi-product with rectangular sections can be calculated in different passes by way of the grade of lengthening:

$$K_i = \frac{1}{1 - \varepsilon_i(1 - f_i)} \tag{5.18}$$

where ε_i it is relative reduction /removal rate in the i-th pass

f_i it is an indicator of spreading in the i-th pass. It depends on the bite length l_z and the width of a semi-product in the preceding pass b_{i-1} (Table 5.2).

Table 5.2. Values of the indicator of spreading f

l_z/b_{i-1}	0,4	0,5	0,6	0,8	1,0	1,2	1,4	1,5
f	0,19	0,20	0,21	0,23	0,27	0,32	0,37	0,40

5.3.3.2 Lengthening on the mandrel

It is a part of the technological procedure for forging of hollow bodies. The punched rough forging is fitted on a slightly conical lengthening mandrel and it is lengthened between the anvils using the same method as with the solid forging except that the lengthening mandrel acts as a solid filler which divides the deformation zone to two partial areas between anvils and the mandrel (Fig. 5.14).

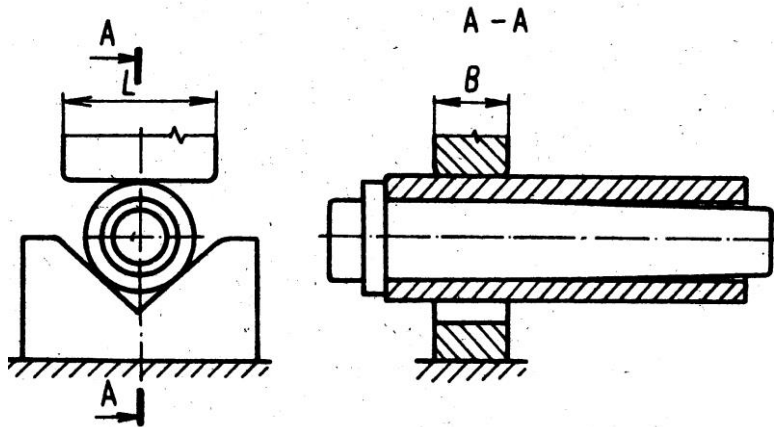

Fig. 5.14. Lengthening on the mandrel

The width of anvils and the length of a bite are chosen as half compared to lengthening of solid forgings. If the thickness of the forging wall is marked as t and the mandrel diameter as D_{pr} , then at $t < D_{pr} / 2$ it is lengthened on the shaped anvils, and at $t > D_{pr} / 2$ it is possible to lengthen on shaped or combined anvils.

5.3.3.3 Through-forging on the mandrel

It is used for forging rings, Fig 5.15. The punched rough forging is forged between the top anvil and the through-forging mandrel which acts as the bottom anvil. After each blow the surface of deformation zone is decreased, however simultaneously the thickness is significantly reduced and the width increases slightly. As a result of these dimensional changes the inner and outer diameters of the forging being through-forged are increasing gradually.

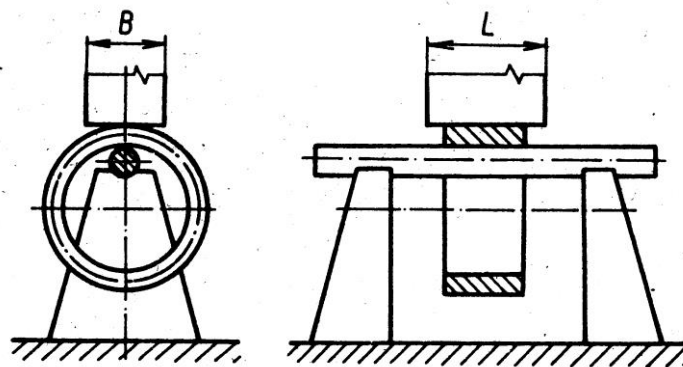

Fig. 5.15. Through-forging on a mandrel

Achieving the required ring size is conditioned by determining the correct dimensions of a punched rough forging based on a spreading factor. Between the rough forging height h_p and the height h of the forging the following relation is valid:

$$h_p = \frac{h}{\beta} h \quad (5.19)$$

Preliminary inner diameter of the rough forging shall be calculated as follows:

$$d_{pa} = 144 \sqrt{\frac{m_v}{h_p}} \quad (5.20)$$

where m_v it is a forging weight (kg).

The punching mandrel of the diameter $D_d < d_{pa}$ shall be chosen and then its external diameter can be calculated as follows:

$$d_p = 411 \sqrt{\frac{m_v}{h_p} + d_p} \quad (5.21)$$

Preliminary diameter of a through-forging mandrel shall comply with:

$$D_{r1} = 0,92d_p \quad (5.22)$$

And its actual diameter D_r shall be chosen so that $D_r < D_{r1}$.

5.3.3.4 Choice of a forming machine

To calculate the deformation forces during lengthening on the hydraulic press the following relation can be used:

$$F = v\psi\sigma_p \left(11 + 0,17 \frac{l_z}{h_o} \right) l_z b_o \quad (5.23)$$

where v it is a coefficient of the anvil shape (for flat plain anvils $v = 1$, for shaped anvils

$v = 1,25$);

l_z it is a length of a bite (mm);

h_o, b_o these are the initial height and width of a lengthened semi-product (m);

ψ, σ_p – the same meaning as in the relation (5.8).

Weight of the ram when lengthening on a hammer shall be calculated by the equation:

$$m_b = 1,7 \cdot 10^5 \left(1 + 0,17 \frac{l_z}{h_o} \right) v\sigma_p \varepsilon h_o b_o l_z \quad (5.24)$$

where m_b it is the weight of a ram (kg)

ε it is the relative reduction/removal rate in height at the first pass; $\varepsilon = 0.1$ to 0.2 .

5.3.4 Stepping and necking/reduction

Basically it is a lengthening of specified parts of the forging. Stepping is carried out on the end parts where a step will arise (Fig. 5.16), and necking is carried out on non-terminal parts of a forging, where a neck will arise (Figure 5.17). In the special case there flanges may arise on the forging (Fig. 5.18).

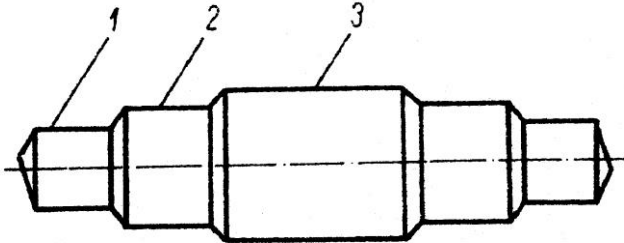

Fig 5.16. Basic shape of a stepped forging
1 – end setting; 2 – adjacent setting; 3 – lug

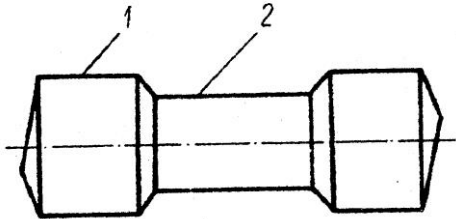

Fig. 5.17. Basic shape of a necked forging
1 - lug; 2 – necking

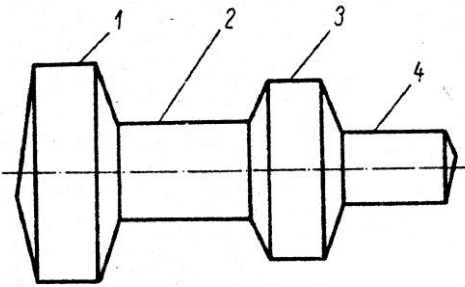

Fig. 5.18. Basic shape of a flanged forging
1 – end flange, 2 - necking; 3 – mid flange; 4 – end stepping

Both operations are applied to the longitudinal solid and hollow forgings whose cross-section is changing along the length gradually. For stepping and necking a local weakening of cross section in the plane of stepping, necking is characteristic. The original dimension d_t or h_t is therefore increased to so called taking-up dimension d_z or h_z , according to the Figure 5.19. For calculation of the taking-up diameter the following relation can be used:

a) for forgings of circular section

$$d_z = d_1 + \frac{d_1 - d_2}{7} \quad (5.25)$$

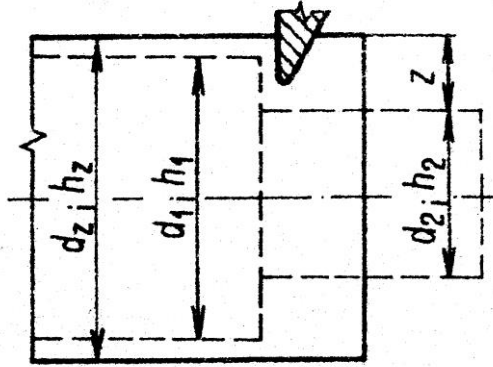

Fig. 5.19. Determination of taking-up dimensions at stepping and necking

b) for forgings of rectangular section

$$h_z = h_1 + \frac{h_1 - h_2}{7} \quad (5.26)$$

Depending on the taking-up (d_z, h_z) and the extent of the stepping z (Fig. 5.19) it is possible to step in three different ways:

1. Using only an anvil,
2. Indication by a circular lap of a diameter D_p and by forming,
3. Indication by a circular lap, cutting by a triangular lap and by forging, while the depth of pushing laps z' down into a stepped semi-product is limited – see the following relation

$$\frac{2}{3}z \geq z' \geq \frac{1}{2}z \quad (5.27)$$

Necking can be carried out only by two methods:

1. Indication by a circular lap and by forging,
2. Indication by a circular lap, cutting by a triangular lap and by forging.

5.3.5 Offsetting

Offsetting depends on transverse movement of a defined volume of the forged semi-product. The longitudinal axis of the resulting offsetting is parallel to the longitudinal axis of the remaining part of the forging. It is used for forging crankshafts and similarly shaped forgings. Preparatory operations are similar to stepping operations but the difference is that the sectional dimension of a forged semi-product (the diameter) before offsetting increases by 25%. The decisive stages of this operation brings the Figure 5.20.

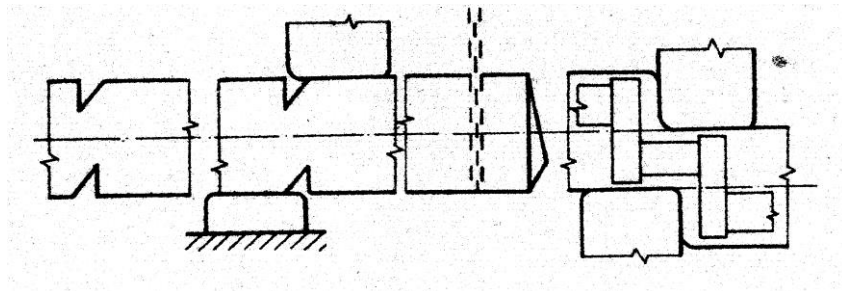

Fig. 5.20. Scheme of offsetting

5.3.6 Bending

By bending the longitudinal axis of forging is curved, thereby changing the shape of its cross section in the zone of deformation (Fig. 5.21), and thus more strongly, the greater is the thickness of a bended semi-product t , the smaller is the bending radius r and the larger is the bend angle α . Compressive stresses on the inner contour of the forging lead to folding, tensile stresses on the outer contour may give rise to transversely oriented cracks. The neutral axis unaffected by deformations moves to the inner contour of the bended forging. If the bending radius is $r < (1 \text{ to } 1.5) t$, then the neutral axis is located at a distance of $t / 3$ from the inner contour.

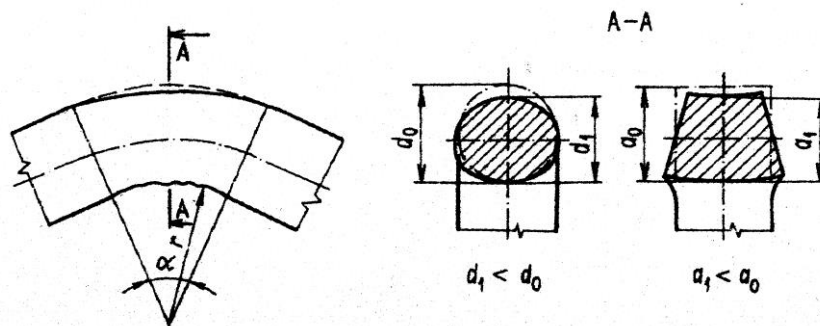

Fig. 5.21. Change of the shape and dimensions of the zone of deformation at bending a semi-product with circular and square cross-sections

Weakening of the cross section shall be removed by reinforcement of the initial semi-product in the deformation zone. Bending can be applied in the manufacture of hooks, anchors, clamps, rods, etc. The operation is generally carried out in the range of lower forging temperatures ($850\text{-}950^\circ\text{C}$), using simple preparations.

5.3.7 Twisting

The basic operation of twisting is turning slightly the defined portion of a forging to adjacent portions of the forging by a certain angle around the common axis (Figure 5.22). The larger is the diameter of the twisted portion and the larger is the twisting angle, the more tensile stresses can arise on the surface. The angle of twisting is determined with regard to the formability of steel. Typically it is less than $\alpha = 90^\circ$. Twisting is a supplementary operation while completing crankshafts.

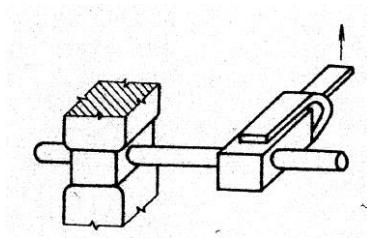

Fig. 5.22. Scheme of twisting

The force needed for generation of a required torque is calculated as follows

$$F = 0,13 \frac{d^3 \sigma_p}{L \cos \alpha} \quad (5.28)$$

Where F is a force in MN

d it is a forging diameter at the spot of twisting operation (mm), σ_p it is a natural deformation resistance of steel (MPa), L it is a length of the fork arm (mm), α it is a twisting angle ($^\circ$).

5.3.8 Chiselling

Chiselling is used when dividing the initial semi-product to blocks or in the separation of surplus and waste material from forgings. The chisel creates a slender zone of deformation, where additional tensile stresses dominate which are able to accelerate dividing the semi-product in the plane of chiselling. Forgings of a rectangular section are chiselled gradually from one, two, or four sides, semi-products of circular section from three sides (Figure 5.23). At quadrilateral chiselling the cut area is the most purest and almost without a flash, which is generally the side-effect of other methods of cutting.

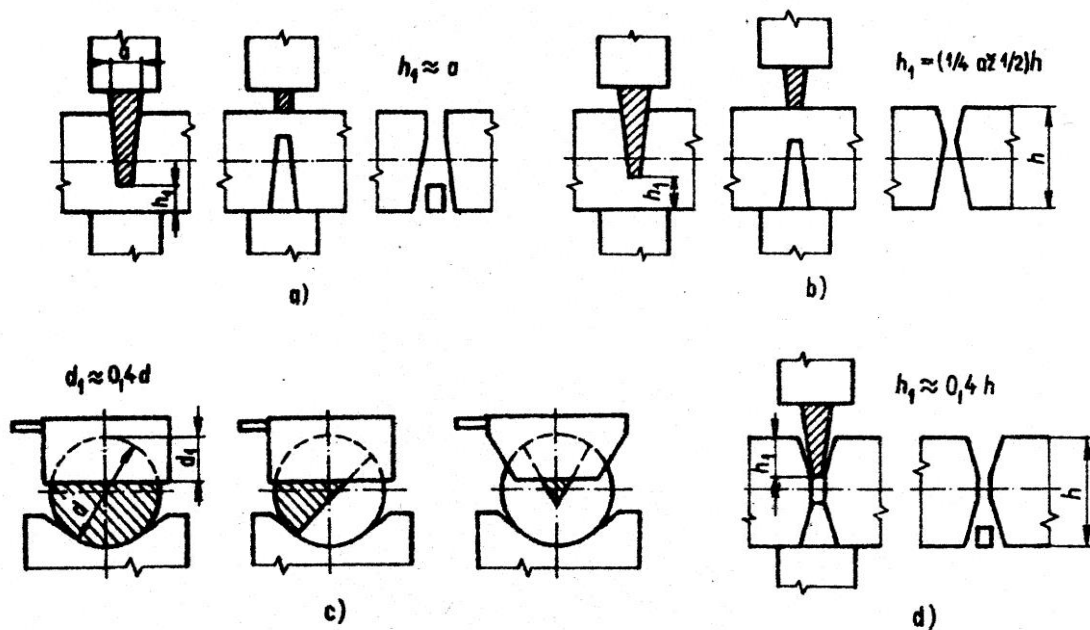

Fig. 5.23. Basic methods for forging chiselling
a) one-sided b) double-sided, c) three-sided d) four-sided

Questions:

- 1 Can you characterize the basic shape of semi-products for open die forging?
 - 2 How to calculate the grade of through-forging?
 - 3 How to characterize operations of open die forging?
-

Tasks to solve:

1. Calculate the grade of through-forging according to the relations 5.2 and 5.6 and analyse the results.
 2. Do an analysis of single methods of punching and choose a suitable method for punching the semi-products of the slenderness in the interval $0.5 \leq h/d \leq 0.8$.
-

6. EFFECT OF FORGING PROCEDURE ON CLOSING IMPERFECTIONS IN FORGINGS

Chapter contents:

- Imperfections in forgings
- Effect of forging procedure on closing imperfections
- Calculation of basic parameters of forging on closing imperfections



Time needed for studying: 120 minutes

Aim: After studying of this chapter

- You will be able to determine effect of procedure of open die forging on closing imperfections in forged pieces
- You will be able to calculate the relative length of a bite / stroke
- You will understand the influence of uneven deformation on closing imperfections in forgings



Explication

The intensity of the structure changes, closing internal imperfections in ingots and properties of forgings in extending/lengthening on flat plain anvils is usually determined depending on the grade of through-forging. The grade of through-forging during lengthening is calculated by simple relations that are based on the change in forgings cross section. Besides simple changes of cross sections the intensity can be affected by the structure and the relative length of the bite/stroke, the extent of deformation in the individual passages, the method of chamfering, temperature, friction and shape of anvils. The article analyses the influence of the relative length of the bite, and the extent of deformation at closing imperfections in forgings.

When lengthening semi-products of rectangular cross-section on flat plain anvils the process of changes of the shape of the cross section is realized according to the scheme “square - rectangle – square” and an outlined change in the shape of the body being lengthened are significantly affected by relations among three main deformations. The main and largest deformation is the deformation in height. Because the lengthening consists of a series of consecutive bites/strikes and the deformations are summed up in the direction of lengthening, i.e., in the direction of the longitudinal axis of the rough forging, the resulting lengthening greatly exceeds the main deformations in remaining two directions.

The grade of through-forging during lengthening can be described by the following relation

$$K = \frac{1}{1 - \varepsilon(1 - f)} \quad (6.1)$$

where ε it is a relative deformation, f is a spreading coefficient. The values of spreading f depend on the length of a bite l_z and on the width b_o of a semi-product being lengthened before the bite:

$$f = \varphi\left(\frac{l_z}{b_o}\right) \quad (6.2)$$

The Coefficient of spreading f characterizes with its significance the volume of metal which is moved in the width direction. When $f = 0$ the spreading is suppressed and at $f = 1$ lengthening operation does not cause the semi-product lengthening. Due to a more detailed analysis the relation (2) can be modified as follows:

$$f = \frac{(b - b_o)h}{(h_o - h)b_o} = \frac{b - b_o}{b_o} \cdot \frac{h_o - h}{h} = \frac{\varepsilon_{b_o}}{\varepsilon_h} \quad (6.3)$$

Where ε_{b_o} it is a relative spreading and ε_h it is a relative deformation in height.

In addition to the above mentioned relation the relationships between spreading and vertical deformation can be described with the aid of deformation coefficients but also by means of the actual deformations:

$$\frac{1}{\gamma} = \lambda \cdot \beta \quad (6.4)$$

$$\frac{\ln \lambda}{\ln 1/\gamma} + \frac{\ln \beta}{\ln 1/\gamma} = 1$$

This means that the sum of the volumes displaced in the direction of length and width is equal to one. Volume displaced in the direction of $\ln \lambda / \ln (1 / \gamma)$ is considered as an indicator of lengthening and it is marked with the symbol q . The relationship between the indicators of spreading and lengthening satisfies the condition:

$$f + q = 1 \quad (6.5)$$

Lengthening complying with the condition $l_z/b_o = 1$ divides the total deformation in height to 27% of spreading and 73% of lengthening.

6.1. Influence of the grade of through-forging on closing imperfections

The relative length of the bite l_z/h_o decides about penetration of plastic deformation into the depth of deformation zone, about the stress state and uneven deformation in this area. The importance of the relative length of the bite comes to the fore when forging semi-products of cast structure, that is, some continuously cast semi-products and ingots. In this case the selection of factors related to lengthening is to be focused on transformation of the cast structure to a formed structure with desired properties of the forging. The relative length of the bite presents the slenderness of the deformation zone during lengthening.

Optimal conditions for perfect through-forging of the axial portion of lengthened semi-products can be achieved if the relative length of the bite lies in the range $0.5 < l_z/h_o < 0.7$. In

this case, the deformation zone is the area under the influence of compressive stresses which contribute to the closing imperfections in the cast structure.

If during any lengthening the relative length of the bite meets the condition $l_z/h_0 < 0.5$, so in the axis part of a semi-product being lengthened there tensile stresses arise, which can worsen conditions for closing imperfections and transversely oriented internal cracks can be created in low formable steels.

When the proportional stroke length is $l_z/h_0 > 0.7$ the pressure stresses in the axial portion of the semi-products blank increase, which is favourable in terms of through-forging of this area, but the volume of metal being moved in the width direction also increases and longitudinal tensile stresses are formed on the free side surface of the semi-product.

6.2 Non-uniformity of deformation when lengthening

Non-uniformity of deformation in elongation is significantly affected by the relative length of the bite. By reducing the relative length of the bite the non-uniformity of deformation decreases. When enlarging a relative length the result is contrary. When lengthening large forgings it is recommended to lengthen with the relative length of a bite $l_z/h_0 = 0.5$ to 0.6 , because then no unfavourable tensile stresses are produced in the axis part of the semi-product while ensuring the satisfactory and uniform course of deformation along the entire length of the forging. For low-formable steels prone to cracking it will be more advantageous to choose a bigger relative length of a bite, while the steels with good formability can be lengthened with a smaller length of a bite/shot. When lengthening in several passes it is possible to reach the more uniform deformation by offsetting the borders of the deformation zone in the individual passages.

6.3 Effect of a relative length of bite on through-forging

The grade and level of through-forging is used for selection of individual basic operations in order to achieve the desired mechanical properties in the finished forging. For the calculation of through-forging there are used empirical relations that are based on the change of the cross section of the rough forging (a forging) during forging process. When forging longitudinal forgings the level of through-forging is calculated the most often on the basis of two operations (upsetting and lengthening) and their mutual combinations which should influence final properties of forgings. For longitudinal forgings the last operation on which there is lengthening the following relation shall be used:

$$PK = A^2 P^n K \geq 3 \quad (6.6)$$

where PK it is a grade of through-forging, A is a upsetting equivalent, P is a grade of the ingot upsetting, K is a grade of the ingot lengthening, n is a number of upsetting operations.

In cases when upsetting ($n = 0$) is not integrated into the technological procedures the equation (6.6) shall be modified to the form:

$$K = \frac{S_i}{S_v} \geq 3 \quad (6.7)$$

where S_i , it is an area of the ingot cross section and S_v is an area of the forging cross section.

The relation (6.6) is applicable for lengthening on flat plain anvils with the relative length of bite $l_z/h_i = 0.6$. The grade of through-forging depends also on the ingot size, a larger ingot has a worse structure and requires a higher grade of through-forging. For the standard range of ingots it is possible to determine the grade of through-forging on the basis of weight of the ingot body (m_i) according to the relation:

$$PK = 2,5 m_i^{0,0764} \quad (6.8)$$

For calculation of the grade of through-forging it is also possible to use the formula coming out of the deformation energy. When lengthening on flat plain anvils the following relation shall be used for calculation of the deformation energy.

$$A = k V \ln \frac{h_{i-1}}{h_i} \quad (6.9)$$

Where k it is a real deformation resistance of steel when lengthening, V is the volume of a semi-product being lengthened, h_{i-1} and h_i it is the initial a final height of a semi-product being lengthened (where $i = 0$ to n). After the equation (8) modification we obtain the following relation:

$$PK \equiv \frac{h_{i-1}}{h_i} = \exp\left(\frac{A}{k V}\right) \quad (6.10)$$

At hypothetical lengthening of square cross sections on flat plain anvils without spreading it is valid: $h_0 = b_1$; $h_1 = b_2$; $h_2 = b_3$; ... $h_{n-1} = b_n$. After a modification we obtain the analogical relation conformable to the equation (6.7):

$$K = \frac{h_0 b_0}{h_n b_n} \quad (6.11)$$

However, at lengthening on flat plain anvils it is valid: $h_0 < b_1$; $h_1 < b_2$; $h_2 < b_3$... $h_{n-1} < b_n$. If to the calculation of the grade of through-forging the size of spreading in the individual passes is included we obtain the following relation:

$$K_s = b_0/h_1 \cdot b_1/h_2 \dots b_{n-1}/h_n \quad (6.12)$$

Comparing the size of the grade of through-forging according to the equations (6.11) and (6.12) we find out that $K_s > K$, which means that through-forging at lengthening and free spreading (K_s) is bigger than through-forging without spreading (K). The K_s value is the product of relative deformations in height in individual passes, while K is the product of proportion of cross-sections. The K value depends only on the initial and final section of the body being lengthened, while the K_s value is dependent also on the relative length of the bite l_z/h , the length of the zone of deformation, friction coefficient and size of reduction/removal rate in individual passes.

6.4. Influence of basic parameters on the grade of through-forging

When lengthening rectangular cross-sections on the flat plain anvils the grade of through-forging in a forging axis and thus closing imperfections will depend in direct proportion on the relative reduction /removal rate ε and on the initial width of a semi-product b_0 being

lengthened inversely proportional to the length of the bite, while also the shape of anvils will play an important role, the appropriate shape of which can increase the proportion of shearing deformations in the axis of the semi-product being lengthened. The given parameters of lengthening were experimentally tested in laboratory conditions. Experiments were performed on steel samples of square section 40 x 40 mm, while a hole with a diameter of 3 mm was drilled in the longitudinal axis of the sample. The samples were divided into three groups that differed each other in size of the relative length of bite which was set in the interval: $l_z/h_0 = 0.3; 0.5; 0.8$ and 1.1. In each group three samples were forged according to the following program:

- a) Sample 1 – lengthening with relative reduction /removal rate $\varepsilon = 10\%$
- b) Sample 2 – lengthening with relative reduction /removal rate $\varepsilon = 20\%$
- c) Sample 3 – lengthening with relative reduction /removal rate $\varepsilon = 30\%$

Individual samples were lengthened at the given relative length of bite on flat and shaped anvils. With the aid of shaped anvils the shearing deformation was increased in the sample cross-section. After each pass the height and width of samples were measured. Forged samples were cut into several transverse slices into 6 parts, the cut surface was adjusted metallographically, and the change in the shape of original circular cross-section of the drilled hole was evaluated. Macrostructure and microstructure in the area of drilled holes of selected samples is shown in Figures 6.2 to 6.6. In the Figures 6.1 to 6.6 there are only cross sections of samples after forging on shaped anvils.

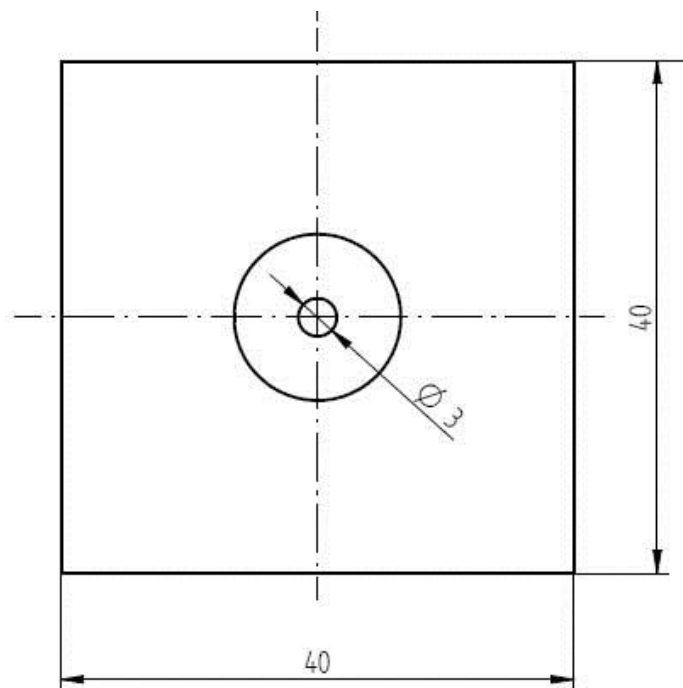
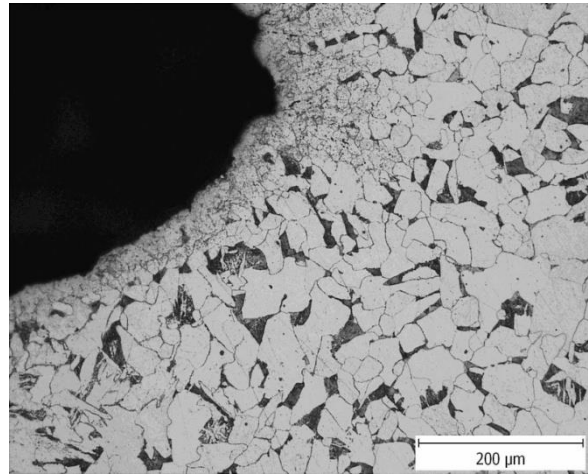

Fig. 6.1 Initial cross section of the sample



a)



b)

Fig. 6.2 Macrostructure and microstructure of a sample after lengthening: $\varepsilon = 10\%$; $l_z/h_0 = 0.4$

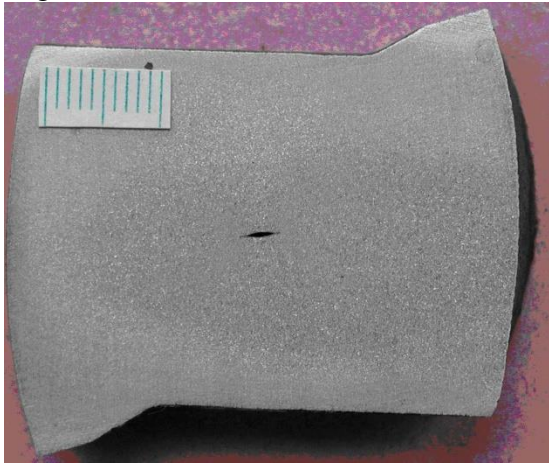

a)

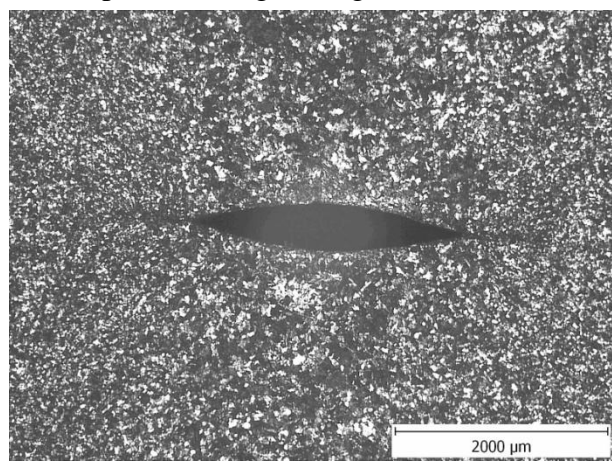

b)

Fig. 6.3 Macrostructure and microstructure of a sample after lengthening: $\varepsilon = 20\%$; $l_z/h_0 = 0.4$

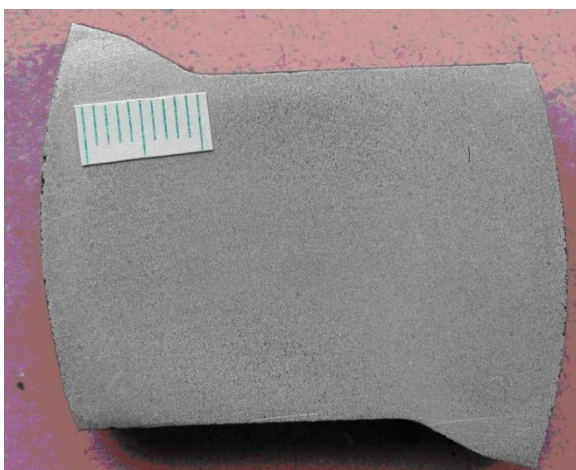

a)

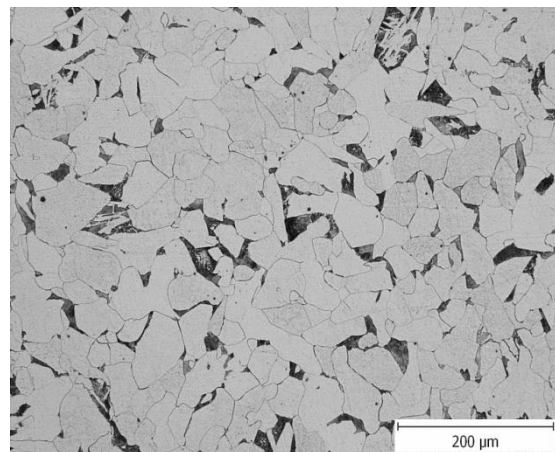

b)

Fig. 6.4 Macrostructure and microstructure of a sample after lengthening: $\varepsilon = 20\%$; $l_z/h_0 = 0.7$

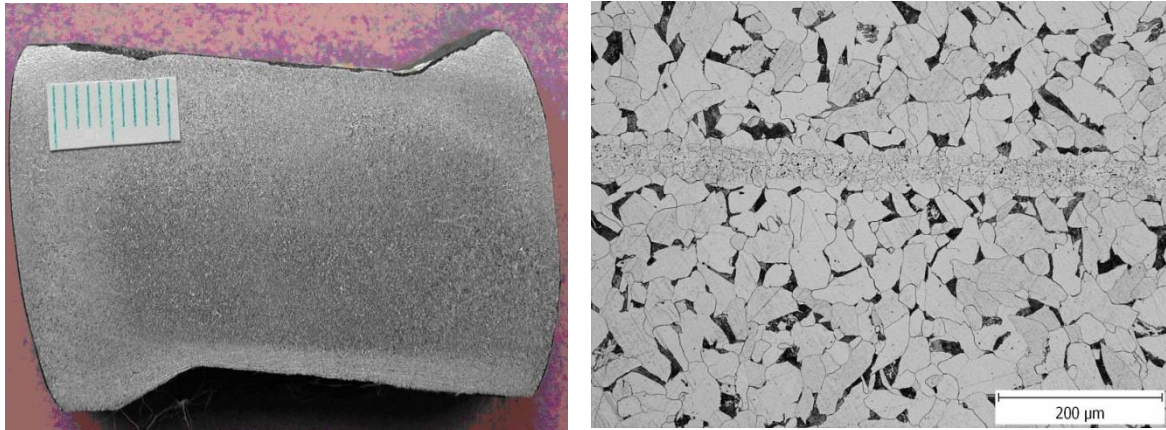

a)

b)

Fig. 6.5 Macrostructure and microstructure of a sample after lengthening: $\varepsilon = 30\%$; $l_z/h_o = 0.7$

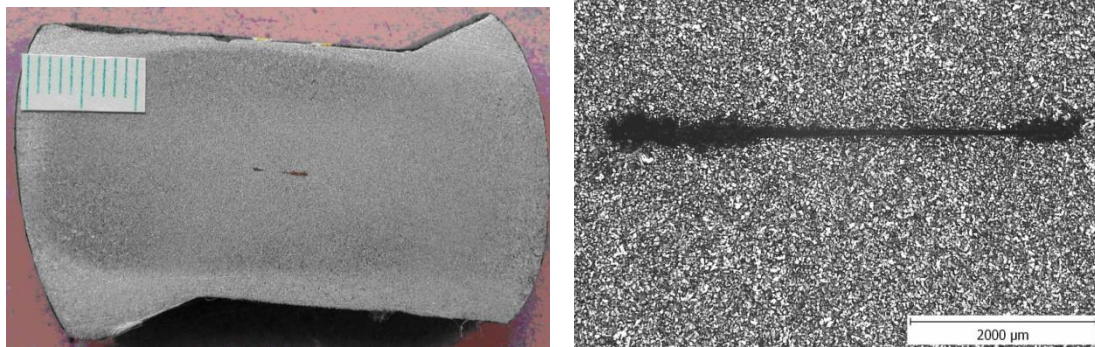

a)

b)

Fig. 6.6 Macrostructure and microstructure of a sample after lengthening: $\varepsilon = 30\%$; $l_z/h_o = 0.4$

The results of lengthening obtained during forging on flat plain anvils are summarized in the Tables 1 to 3. The calculated values for the relative removal rate $\varepsilon = 10$ to 30% and the relative length of the bite $l_z / h_o = 0.3$ to 1.1 are shown in Tab. 6.1.

Table 6.1 Quantities characterizing lengthening of samples with different relative length

l_z/h_o	ε [%]	h_n [mm]	b_n [mm]	S_n [mm ²]	K_n	K
0,3	10	36,1	41	1480	1,081	1,081
	20	31,9	42,5	1310	1,130	1,221
	30	27,9	43,0	1200	1,092	1,333
0,5	10	36,2	40,3	1460	1,096	1,096
	20	32,0	41,6	1330	1,068	1,203
	30	28,3	41,9	1185	1,122	1,350
0,8	10	36,1	40,6	1464	1,093	1,093
	20	32,2	42,5	1368	1,070	1,170
	30	28,0	42,9	1200	1,140	1,333
1,1	10	36,2	39,1	1416	1,07	1,07
	20	32,0	42,5	1360	1,041	1,175
	30	28,0	43,4	1216	1,118	1,136

The course of curves of the lengthening intensity can be described by the equation:

$$K = a \cdot e^{-\alpha(l_z/h_o)} \quad (6.13)$$

Quantities a , α are the functions of relative removal rates. The calculated values of the lengthening of the K grade are given in the Table 6.2 and it is possible to state:

Table 6.2 The values of quantities a - α

ε [%]	10	20	30
a	1,095	1,21	1,354
α	0,015	0,0274	0,0385

The biggest influence on the intensity of lengthening on the flat plain anvils has a length of bite related to the initial width of a semi-product, i.e. l_z/b_o and a reduction / removal rate ε . Effect of the relative length of the bite l_z/h_o is practically negligible, which is very convenient, because when you choose it, you can fully concentrate on inducing favourable state of stress. Effect of chamfering on the intensity of lengthening is given in Table 6.3

Table 6.3 Quantities characterizing lengthening of rectangular cross-section with chamfering after each pass ($l_z/h_o=0,5$), the size of relative deformation in individual passes $\varepsilon=20\%$

Number passes - n -	Length - l_z [mm]	h [mm]	b [mm]	b/h	S [mm ²]	K
1	20	31,7	43,0	1,36	1305	1,23
2	22	34,4	34,6	1,01	1184	1,35
3	19	26,6	37,2	1,40	932	1,72
4	15	29,6	29,0	0,98	836	1,91
5	16	23,0	31,4	1,37	720	2,22
6	13	15,3	25,2	1,00	632	2,53

The degree of lengthening decreases with increasing the relative length of a bite, and it is the more significant the higher is the total removal rate. Within the relative length of the bite $l_z/h_o = 0.5$ to 0.8 the decrease of intensity is negligible and it moves in thousandths of pct. It can be concluded that the relative length has little effect on the intensity of lengthening, however it has a significant impact on the penetration of deformation into the axis of a lengthened semi-product (Fig. 6.7) and creates favourable conditions for forging-in imperfections in the forging axis.

On the basis of the experimental values the graphic representation was plotted for "closing imperfections in the forging axis" dependent on a relative length of a bite, for flat and shaped anvils which increases the proportion of shearing deformation in the forging cross-section being lengthened.

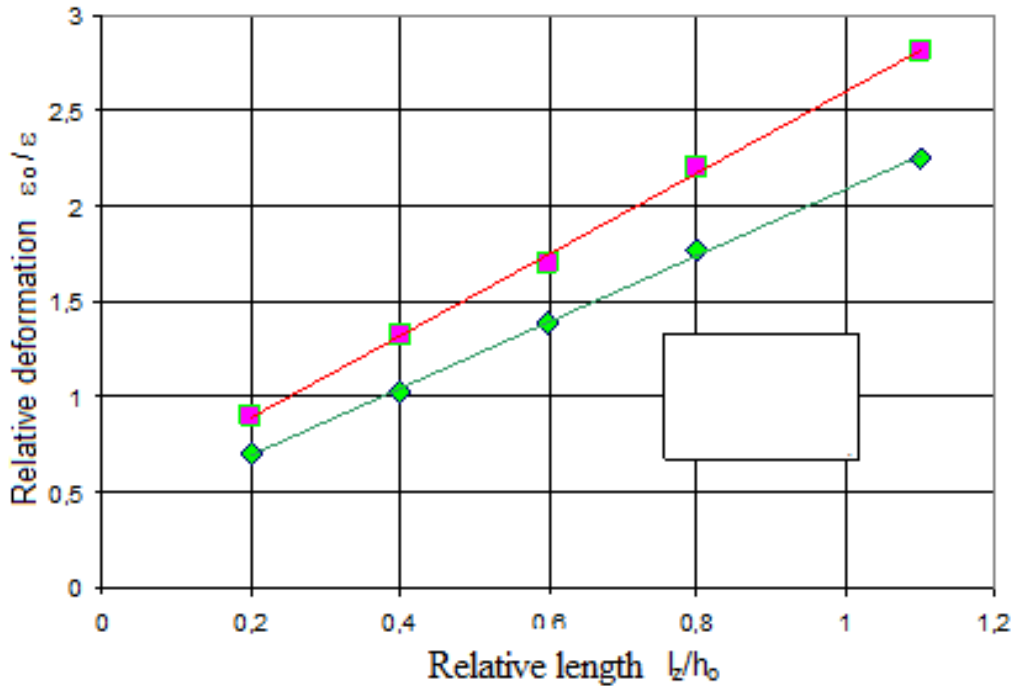

Fig. 6.7 Through-forging of the on-axis area of the forging (ϵ_0/ϵ) on flat and shaped anvils In dependence on a relative length of a bite l_z/h_0 , where ϵ_0 is a relative deformation in the forging axis, ϵ is a relative deformation of the “entire” cross section of the forging

6.5 Recommended procedure of forging

When analysing the lengthening of rectangular cross-sections on flat plain anvils it is necessary to analyse the influence of the relative length of a bite (l_z/h_0), as well as the length of deformation zone (l_z/b_0) on spreading at lengthening. At a relatively great length of a bite there is a danger of the blacksmith cross occurrence and at great length of the deformation zone transverse cracks can be formed on the free side surface of a lengthened body, and further there is greater spreading, thereby the intensity of lengthening is decreasing. And the deformation strength is increasing too. The described defects occur most often when extending with the relative length of a bite $l_z/h_0 \geq 1$.

If steels with a favourable formability are processed by lengthening, then there is no risk of occurrence of the above mentioned defects. Due to greater spreading the time of lengthening of rectangular cross-sections on wide anvils is longer, but it is accompanied by a higher grade of through-forging than at lengthening on narrow anvils, which can result in omission of upsetting operation, if it is aimed at increasing the grade of through-forging.

When lengthening by narrow and wide anvils the deformation energy is constant for gaining the same grade of through-forging. The presented findings can be used in the design of technological processes for forging of rectangular cross-sections on flat plain anvils.

7. TECHNOLOGICAL PROCEDURES FOR FORGING OF LONGITUDINAL FORGED PIECES

Chapter contents:

- Construction of a forging shape
- Calculation of the weight of forging and ingot
- Grade of through-forging
- Technological procedure of forging



Time needed for studying: 120 minutes

Aim: After studying this chapter

- You will learn the principles for determining the optimal shape of forging
- You will be able to work up the technological procedure of forging
- You will be able to calculate the deformation forces
- You will be able to calculate the weight of a forging and the weight of an input semi-product



Explication

7.1 Forging shape

The bearer of initial information is the product drawing. Its dimensions shall be increased or decreased with a forging allowance, i.e. addition of material to surfaces being machined. The forging allowance includes:

1. Machining allowance - addition of material on the machined surface of the product necessary to achieve the satisfactory surface quality
2. Technological allowance - addition of material which simplifies the shape of the product so that it can be forged economically,
3. Allowance to the complexity of shape - addition of material for stepped parts of the forging wherein the ratio of the diameters or thicknesses of adjacent portions is greater than 1.6.

For forgings that are heat treated a roughing allowance shall be projected, it is a special addition of material on the surface of products that are heat treated in roughing condition.

To forged bars and rods, longitudinal forgings and hollow bodies there is added more material for a deviation of geometric shape in the form of a lateral draft /chamfer of a forging. All kinds of material allowances and limited deviations in dimensions are determined by the characteristic dimensions of product standards, according to which the forgings are divided into five basic shape categories:.

- Forged bars and rods,
- Longitudinal forgings;
- Discs and circular plates,
- Rings,
- Hollow bodies.

The characteristic dimension of the product is a cross-sectional dimension and a length. A part of standards are also other design guidelines for forgings.

In addition to the normal version, the forgings are also produced in the precise workmanship finish that is characterized by small forging allowance and a narrowed dimensional tolerance. Accurate forgings are made by prior agreement between the manufacturer and the customer. By a similar agreement the construction of forgings complex in shape that can not be classified in any of the five groups of forgings mentioned above in the text is also conditioned.

7.2 Material balance

The weight of an initial semi-product with formed structure can be calculated as follows:

$$m_o = \frac{m_{vt}}{\eta} 100 \quad (7.1)$$

Where m_o it is the weight of original material (kg),
 m_{vt} it is a calculated /theoretical weight of a forging (kg),
 η it is an utilization of an initial semi-product (%),

$$m_{vt} = km_{vj} \quad (7.2)$$

Where k it is a shape factor, which includes the metal in lateral drafts, end rounding-off, the surface roughness of forging; according to the type of forging $k = 1.04$ to 1.24 ,
 m_{vj} it is a nominal weight of the forging, which is calculated from the nominal dimensions of a forging (kg);

$$\eta = [100 - (o + t)] \quad (7.3)$$

o it is a proportion of burnt-off from the entire weight of an initial semi-product [%]; for the first warming-up

$o_1 = 2 \%$, for every other heating $o_{2,3} = 1.5 \%$,

t it is a proportion of technological waste of the entire weight of an initial semi-product [%]; when punching it is according to the relation (7.11)

When choosing an ingot the relation (7.1) shall be used. To a forging of a calculated/theoretical weight m_{vt} an ingot of with an utility weight of $m_{uz} > m_{vt}$ shall be chosen.

Calculation of a rolled semi-finished product depends on the type of the first forging operation, by which the semi-product has been processed. For the calculation the following formula is used:

$$S_o = (1,3 \text{ až } 1,5)S_v \quad (7.4)$$

Where S_o it is a calculated cross section of an initial semi-product [m^2],
 S_v – the largest cross section of a forging [m^2].

Cross-sectional shape is chosen either square or circular. Depending on the selected shape and value S_o a semi-product shall be selected from the initial program of rolling mills with the cross-sectional area of

$$S_b \geq S_o \quad (7.5)$$

For an initial semi-product that is upset at first, the thickness shall be calculated from the relation

$$t_o = k^3 \sqrt{\frac{m_o}{S_o}} \quad (7.6)$$

where k it is a shape factor; for a square section $k = 0.05$, for a circular section $k = 0.054$,
 s_o it is a slenderness of an initial semi-product; $s_o \leq 2,5$.

The length of a semi-product shall be determined from the law of constancy of the volume of weight:

$$l_o = \frac{m_o}{\rho S_o} \quad (7.7)$$

where m_o it is a weight of a semi-product[kg],
 ρ is a density [$kg \ m^{-3}$]
 S is a bar/rod cross section [m^2]

7.3. Technological procedures destined for forged pieces from ingots made by open die forging

When forging longitudinal forged pieces from semi-products with cast structure there is the aim of achieving the desired mechanical properties, shape and single dimensions of each forging. Design of technological procedure of forging consists of a design of a forging shape (the Blacksmith sketch), the determination of the operating scheme of forging, however only three basic schemes are sufficient:

- Forging procedure using only lengthening,
- Forging procedure using upsetting and lengthening,
- Forging procedure using double upsetting and lengthening.

The following is a complement of the selected scheme of forging with other technological operations (heating, forging of handling pin, etc.). The procedure of forging of longitudinal forged pieces is shown on the example of a forged piece destined for cold rolling mill.

7.3.1 Blacksmith sketch

The forging shall be made according to the calculated dimensions which shall be recorded in the drawing. The machining allowances and technological additions / production allowance shall be determined.

a) Machining allowances

According to the shape the machined part is to be classified to a corresponding group for longitudinal forgings. Proposal of the forging shape shall be made according to CSN 42 9011 (Steel forgings made by open die forging, of a standard version, longitudinal). Roughing allowances for different shapes of forgings shall be determined from tables (Table 7.1).

Table 7.1. Roughing allowances for longitudinal forgings

Diameter of forgings [mm]	Length of forgings [mm]							
	1000 ÷ 1250	1250 ÷ 1600	1600 ÷ 2000	2000 ÷ 2500	2500 ÷ 3150	3150 ÷ 4000	4000 ÷ 5000	5000 ÷ 63000
200 - 250	9	9	10	11	12	14	16	19
250 - 315	10	11	11	12	14	15	17	20
315 - 400	12	12	13	14	15	17	19	22
400 - 500	14	14	15	16	17	19	21	24
500 - 630	16	17	18	19	20	22	24	26
630 - 800	20	20	21	22	23	25	27	30
800 - 1000	24	25	26	27	29	31	34	37
1000 - 1250	28	28	29	30	31	33	35	38
1250 - 1600	35	35	36	37	38	40	40	40

Machining allowances p_d , p_l and maximum deviations (u_h , u_d) shall be determined according to the tables (table 7.2), or they shall be calculated with the aid of empiric relations.

Table 7.2. Machining allowances

Diameter of forgings [mm]		Lengt of forgings [mm]								
		n pl								
		2,5					3,0			
		$p_d \pm \delta$								
		1000 - 1250	1250 - 1600	1600 - 2000	2000 - 2500	2500 - 3150	3150 - 4000	4000 - 5000	5000 - 6300	6300 - 8000
200	250	20 ⁺¹⁰ ₋₅	21 ⁺¹¹ ₋₅	22 ⁺¹⁰ ₋₆	24 ⁺¹² ₋₆	25 ⁺¹³ ₋₆	27 ⁺¹⁴ ₋₇	28 ⁺¹⁴ ₋₇	30 ⁺¹⁵ ₋₈	32 ⁺¹⁶ ₋₈
250	315	22 ⁺¹¹ ₋₆	24 ⁺¹² ₋₆	25 ⁺¹³ ₋₆	27 ⁺¹⁴ ₋₇	28 ⁺¹⁴ ₋₇	30 ⁺¹⁵ ₋₈	32 ⁺¹⁶ ₋₈	33 ⁺¹⁷ ₋₉	36 ⁺¹⁸ ₋₉
315	400	25 ⁺¹⁷ ₋₈	27 ⁺¹⁸ ₋₉	28 ⁺¹⁹ ₋₉	30 ⁺²⁰ ₋₁₀	31 ⁺²¹ ₋₁₀	33 ⁺²² ₋₁₁	35 ⁺²³ ₋₁₂	37 ⁺²⁵ ₋₁₂	40 ⁺²⁷ ₋₁₃
400	500	28 ⁺¹⁹ ₋₉	30 ⁺²⁰ ₋₁₀	31 ⁺²¹ ₋₁₀	33 ⁺²² ₋₁₁	35 ⁺²³ ₋₁₂	38 ⁺²⁵ ₋₁₃	39 ⁺²⁶ ₋₁₃	42 ⁺²⁸ ₋₁₄	45 ⁺³⁰ ₋₁₅
500	630	31 ⁺²¹ ₋₁₀	33 ⁺²² ₋₁₁	35 ⁺²³ ₋₁₂	37 ⁺²⁵ ₋₁₂	39 ⁺²⁶ ₋₁₃	42 ⁺²⁸ ₋₁₄	44 ⁺²⁹ ₋₁₅	47 ⁺³¹ ₋₁₆	50 ⁺³³ ₋₁₇
630	800	35 ⁺²³ ₋₁₂	37 ⁺²⁵ ₋₁₂	39 ⁺²⁶ ₋₁₃	41 ⁺²⁷ ₋₁₄	44 ⁺²⁹ ₋₁₅	47 ⁺³¹ ₋₁₆	49 ⁺³³ ₋₁₆	53 ⁺³⁵ ₋₁₈	56 ⁺³⁷ ₋₁₉
800	1 000	39 ⁺²⁶ ₋₁₃	41 ⁺²⁷ ₋₁₄	44 ⁺²⁹ ₋₁₅	46 ⁺³¹ ₋₁₅	49 ⁺³³ ₋₁₆	52 ⁺³⁵ ₋₁₇	55 ⁺³⁷ ₋₁₈	59 ⁺³⁹ ₋₂₀	62 ⁺⁴¹ ₋₂₁
1 000	1 250	44 ⁺²⁹ ₋₁₅	46 ⁺³¹ ₋₁₅	49 ⁺³³ ₋₁₆	52 ⁺³⁵ ₋₁₇	55 ⁺³⁷ ₋₁₈	58 ⁺³⁹ ₋₁₉	61 ⁺⁴¹ ₋₂₀	65 ⁺⁴³ ₋₂₂	69 ⁺⁴⁶ ₋₂₃
1 250	1 600	48 ⁺³² ₋₁₆	51 ⁺³⁴ ₋₁₇	55 ⁺³⁷ ₋₁₈	58 ⁺³⁹ ₋₁₉	61 ⁺⁴¹ ₋₂₀	65 ⁺⁴³ ₋₂₂	68 ⁺⁴⁵ ₋₂₃	72 ⁺⁴⁸ ₋₂₄	77 ⁺⁵¹ ₋₂₆

For longitudinal forgings (Figure 7.1), the diameter allowance p_d and the length allowance p_l are the function of maximum diameter and the total length of the machined product:

$$p_d = f(d_{\max}, l_{\Sigma}) \quad (7.8)$$

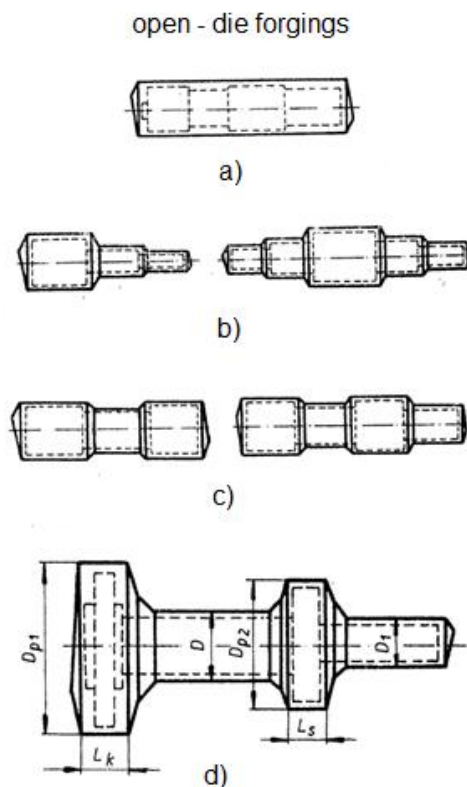

Fig. 7.1 Basic shapes of longitudinal forgings

Dimensions of a forging, including rounding-off of diameters to multiples of five and lengths to multiples of ten shall be determined from the following relations:

$$\begin{aligned}
D_i &= d_i + p_{d-u_d}^{+u_h} \\
L_i &= l_i + p_{l-u_d}^{+u_h} \\
L_k &= l_k \\
L_\Sigma &= l_\Sigma + p_{l-u_d}^{+u_h}
\end{aligned}
\tag{7.9}$$

where D_i, L_i it is the diameter and the length of a forging [mm]

l_i, d_i it is the length of a machined part [mm]

L_k, l_k it is the length of stepping on a forging and the length of stepping on a component [mm]

p_d, p_l it is the machining allowance [mm]

L_Σ, l_Σ it is a total length of a forging and a component [mm].

Besides a machining allowance the forging dimensions shall be adapted with the aid of technological additions / production allowances.

1. Extent of stepping

$$10 \leq z \leq \frac{|u_h| + |u_d|}{2} \tag{7.10}$$

where z it is the extent of stepping, $z = \frac{D_2 - D_1}{2}$

u_h, u_d these are upper and lower limit allowances of diameter [mm],

D_1, D_2 these are dimensions of adjacent diameters [mm].

The shape of the forging shall be checked relative to the stepped parts.

2. The ratio of diameters of adjacent parts of the forging

$$D_2 / D_1 \leq 2,5 \tag{7.11}$$

Where D_1, D_2 it is the basic diameter of a forging and the diameter of the end stepping [mm].

3. Length of end stepping

It shall be calculated fro empirical relations:

$$L_1 = 0,2 \frac{D_2^3}{D_1^2} \tag{7.12}$$

$$50 \leq L_1 \leq 0,1L_\Sigma \tag{7.13}$$

where L_1 it is the length of an end stepping [mm],

L_Σ it is the entire length of a forging [mm].

If the dimensions of the forging do not meet the above listed relations, the operation of stepping is not performed.

4. Size of lateral drafts

For longitudinal necked and stepped ones forgings (except flanged ones) they must satisfy the condition

$$U < 20^\circ \quad (7.14)$$

After adjusting the size and shape of a forging the blacksmith sketch is plotted, Figure 1.7.

5. Determination of initial semi-product

Taking into account the dimensions of the forging it is not possible to use a rolled semi-product. It is necessary to choose a suitable ingot from the product line of forging ingots.

5.1 Ingot weight

For a longitudinal forging of a cylindrical shape for cold rolling (Figure 7.1) it shall be determined:

$$m_i = m_v + m_z \quad (7.15)$$

where m_i it is a calculated /theoretical weight of je the ingot,
 m_v it is a forging weight,
 m_z it is a weight loss.

$$m_v = k (2m_i + m_2) = k \rho (2V_1 + V_2) \quad (7.16)$$

where $V_{1,2} = \pi D^2 L$ it is the volume of the forging individual parts calculated from the nominal dimensions D_1, L_1 and D_2, L_2 ,
 k it is a shape factor,
 $m_{1,2}$ it is the nominal weight (excluding metal in the transitions among individual parts of forging and there is not allowed to use any limit deviations) of individual parts of forging.

$$m_z = m_p + m_t + m_{h,s} \quad (7.17)$$

where m_p it is the weight loss due to iron /smelting loss,
 m_t it is the weight of technological waste , $m_{h,s}$ it is the weight of the ingot top and bottom

$$m_p = m_i (p/100) \quad (7.18)$$

where p is the iron/smelting loss [%]. For initial warming-up $p_1 = 2 \%$, for re-warming-up p_2 to $p_n = 1.5 \%$.

In longitudinal forgings the following is usual:

$$m_t = 0 \quad (7.19)$$

$$m_{h+s} = \frac{h+s}{100} \quad (7.20)$$

Where h, s - the waste of the ingot top and bottom [%]; (h = 20 %, s = 5 %).

$$m_z = \frac{p+h+s}{100} m_i \quad (7.21)$$

$$m_i = m_v + \frac{h+s+p}{100} m_i = \frac{m_v}{1 - \frac{p+h+s}{100}} \quad (7.22)$$

$$m_i = \frac{m_v}{\eta} 100 \quad (7.23)$$

where $\eta = \left(1 - \frac{p+h+s}{100}\right) \cdot 100$ it is the ingot utilization in [%].

b) Ingot dimensions shall be determined from the Table 7.3.

$$m_i^{sk} \geq m_i \quad (7.24)$$

$$\eta^{sk} = \frac{m_v}{m_i^{sk}} \quad (7.25)$$

Table 7.3. Basic series of forging ingots

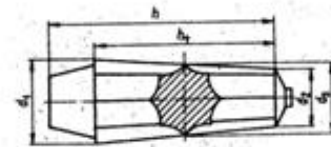

Forging ingot	weight ingot (kg)				draft k _t (%)	ht / d _s	dimension (mm)				
	body	head	bottom	total			h	h _s	d _s	d ₁	d ₂
8K 5,3	4 300	825	175	5 300	4,3	2,21	2 270	1 445	655	716	594
8K 6,7	5 400	1 070	230	6 700	4,2	2,18	2 405	1 545	710	774	646
8K 8,4	6 800	1 320	280	8 400	4,1	2,11	2 525	1 630	775	842	708
8K 10	8 500	1 650	350	10 500	4,1	2,07	2 720	1 740	840	911	760
8K 13	10 700	2 110	440	13 250	4,0	2,02	2 880	1 845	915	988	842
8K 17	13 500	2 900	600	17 000	3,9	1,95	3 135	1 950	1 000	1 076	924
8K 21	17 000	3 350	650	21 000	3,9	1,91	3 340	2 085	1 085	1 166	1 004
8K 27	21 500	4 600	900	27 000	3,8	1,89	3 565	2 230	1 180	1 265	1 095
8K 34	27 000	5 900	1 100	34 000	3,7	1,84	3 880	2 360	1 285	1 375	1 197
8K 43	34 000	7 600	1 400	43 000	3,7	1,79	4 115	2 505	1 400	1 494	1 306
8K 53	42 000	9 300	1 700	53 000	3,6	1,75	4 365	2 645	1 515	1 611	1 419
8K 64	50 000	11 850	2 150	64 000	3,6	1,72	4 680	2 770	1 615	1 714	1 516
8K 76	59 000	14 500	2 500	76 000	3,5	1,68	4 900	2 880	1 720	1 821	1 619
8K 91	70 000	18 000	3 000	91 000	3,5	1,63	5 160	2 990	1 840	1 944	1 736
8K 109	83 000	22 500	3 500	109 000	3,4	1,61	5 465	3 155	1 950	2 058	1 842
8K 130	98 000	27 800	4 200	130 000	3,4	1,60	5 805	3 305	2 070	2 182	1 958
8K 155	116 000	34 000	5 000	155 000	3,4	1,59	6 295	3 495	2 190	2 305	2 072
8K 185	137 000	42 000	6 000	185 000	3,3	1,57	6 620	3 650	2 330	2 451	2 209

Technological procedures of forging

1. Metallurgical aspect of forging

The purpose is to transform the cast structure of the ingot to a formed structure, which requires an optimal grade of through-forging PK. It is usually determined from the relation:

$$PK = A^n \cdot P^n \cdot K \geq 3 \quad (7.26)$$

where A is the upsetting equivalent, P is a level of upsetting, K is the grade of lengthening, n is a number of upsetting operations.

According to this basic formula it is obvious that it is possible to use the operation of upsetting and lengthening in the following variants:

- a) lengthening
 - b) upsetting and lengthening
 - c) upsetting, lengthening, upsetting, lengthening
- ad. a)

$$n = 0 \rightarrow A = 1; P = 1$$

$$PK = K \geq 3$$

$$K = \left(\frac{D_i}{D_v} \right)^2 \quad (7.27)$$

ad. b)

$$n = 1; \rightarrow A = 0,8; P = 2,8$$

$$K \geq \frac{3}{A \cdot P} \quad (7.28)$$

$$D_i \geq 1,16 D_v$$

ad. c)

$$n = 2; \rightarrow A = 0,8; P = 2,8$$

$$K \geq \frac{3}{A^2 \cdot P^2} \quad (7.29)$$

$$D_i \geq 0,774 D_v$$

Where D_i is the mean diameter of ingot [mm],

D_v is the maximum diameter of forging [mm].

From the relationship between the D_i / D_v the right option of forging shall be selected.

2. Technological aspect of forging

The purpose is to assign to the previously selected option of forging subsequent forging operations by means of which the desired forging shape will be achieved. In the case of forging of a backup roll for cold rolling it will be stepping.

a) The sequence of single operations

1. Heating up to top forging temperature

2. Forging of a handling pin of the ingot top. Dimensions of the handling pin satisfy the condition (Figure 2.7):

$$D_{\check{c}} = f(m_i;), L_{\check{c}} > 1,5D_{\check{c}}$$

where $D_{\check{c}}$ is a diameter of a handling pin [mm],

$L_{\check{c}}$ is the length of a handling pin [mm].

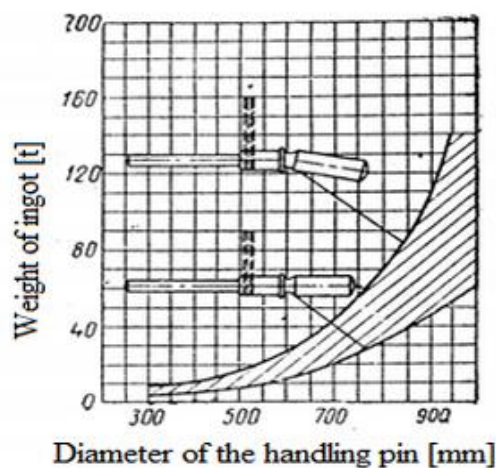

Fig. 7.2. Determination of the handling pin

Forging operation of a handling pin is used in cases where the press workplace is only equipped with forging cranes. The scheme of a device for handling the ingots and forgings is shown in the Figure 7.3

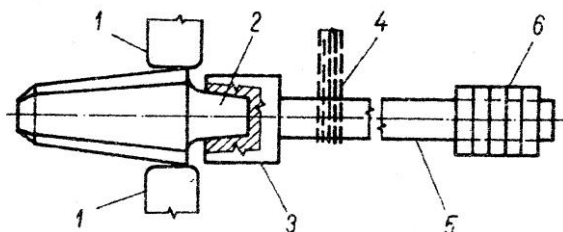

Fig. 7.3. Device for handling heavy ingots and forgings

1 - Anvil; 2 – handling pin of ingot; 3 - sleeve; 4 – Gall's chain; 5 – rocker arm; 6 – counterweights

In one heat ingot edges shall be re-forged (the octagonal cross section is changed to a circular one, the degree of taper of the ingot body is maintained).

3. *Re-warming up to the top / finishing forging temperature*

4. *Ingot upsetting to $P = 2.8$*

5. *Determination of approximate dimensions of a rough forging after upsetting operation*

$$P = \left(\frac{D_p}{D_i} \right)^2 \rightarrow D_p = D_i \sqrt{P} = 1,67 D_i \quad (7.30)$$

$$H_p \cdot D_p^2 = H_t \cdot D_i^2 \rightarrow H_p = \frac{H_t}{P} = 0,36 H_t$$

Where D_p is a diameter of an upset rough forging [mm],

H_p is a height of an upset rough forging [mm],

H_t is a height of the ingot body [mm].

6. *Lengthening of an upset ingot to the diameter D_i :*

7. *Indicating / marking and waste chiselling-off from the ingot bottom*

$$m_o = m_s + 0,03 m_t = \frac{\pi D_i^2}{4} \cdot L_o \cdot \rho \quad (7.31)$$

where m_o is the weight of chiselled bottom of ingot [kg],

m_s is the weight of the ingot bottom [kg],

m_t is the weight of the ingot body [kg].

$$L_o = 1,62 \cdot 10^5 \frac{m_o}{D_i^2} \quad (7.32)$$

where L_o is the length chiselled from an ingot bottom [mm].

8. *Re-warming up to the top / finishing forging temperature*

9. *Repeated upsetting to the value $P = 2.8$*

10. *Lengthening up to biting /taking-up diameter D_z :*

$$D_z = D_2 + \frac{1}{7}(D_2 - D_1) \quad (7.33)$$

where D_z is biting /taking-up diameter [mm].

11. *Selection of stepping method*

12. *Marking/ designation by a triangular lap. Depth of the lap pushing/pressing down shall be determined from the relation:*

$$\frac{2}{3}z \geq h_2 \geq \frac{1}{2}z \quad (7.34)$$

where h_z is the depth of the pushed / pressed lap [mm].

13. Determination of the biting / taking-up length

$$L_{I \text{ až III}} = \frac{V_{I \text{ až III}}}{S_z} = \frac{k \cdot V_{I \text{ až III}}}{S_z} \quad (7.35)$$

where L_I , L_{II} and L_{III} - these are biting /taking-up lengths on the rough forging with the diameter D_z [mm],

S_z is a cross section of a rough forging with the diameter D_z [mm²].

14. Forging the forged piece shape according to the blacksmith sketch and chiselling-off the waste from the ingot

Questions:

1. What is the procedure of plotting a blacksmith sketch?
2. How do you determine the machining allowances?
3. What does the term “technological additions” mean?
4. Why when designing a technological procedure the grade of through-forging shall be determined?

Tasks to solve:

1. Determine the size of machining allowances for backup roll of the rolling-mill stand. The roll has got the following dimensions:
Pin diameter $d_1 = 380$ mm, diameter of the roll body $d_2 = 860$ mm, pin length $l_1 = 420$ mm, length of the roll body $l_2 = 1,250$ mm
2. Plot a blacksmith sketch for the above mentioned backup roll.

8. DROP FORGING ON HAMMERS

Chapter contents:

- Basic shapes of die cavities
- Single- a multi-cavity dies
- Methods of classifying rolled semi-products in forges



Time needed for studying: 120 minutes

Aim: After studying this chapter

- You will be able to describe the shape of die cavities
- You will be able to calculate basic parameters of die cavities
- You will learn the basic methods of dividing the input semi-products in forges



Explication

The flow of metal in the drop forging is limited by the side walls of the cavity in the die. The semi-product is shaped hot or semi-hot. Drop forging is characterized by a small number of operations:

- heating,
- forging,
- forging adaptation,

and by a very short working time. When applying induction heating the warming-up takes tens of seconds, and the contact of the tool with formed metal takes fractions of a second. Much longer, however, are non-working times, especially and primarily handling which can be shortened by mechanization, automation, respectively robotic automation of the production process. The culmination of these intensification efforts is the workplace specialized to one type of forgings, although in different sizes (crankshafts, connecting rods, bolts, fittings, bearing rings, gears, chains, etc.) that are forged on fully automated production lines. Basic stages of the technological process of die forging are given in the scheme:

- initial semi-product
- dividing
- heating
- rough forging
- finish forging

- flush cutting-off (trimming)
- heat treatment
- straightening and calibration
- Finish treatment

As initial semi-products there are rolled rods and bars of circular and square cross-section with a thickness of $t > 20$ mm. The dimensionally accurate forgings are made of drawn round bars of circular sections.

Simple in shape forgings can be forged of initial semi-products in only one die cavity, by so-called single-cavity die forging. Dimensionally more segmented forgings are forged from a suitably prepared rough forging which is made by open die forging or by forging on other forming machines, respectively, by progressive forging in preparatory and finishing cavities in the only one die of a forming machine. Preparatory cavities are divided according to their purpose: Lengthening cavity, forming cavity, bending cavity, roller (cavity for rotary forging), hardy – anvil chisel.

Lengthening cavities are destined for dividing the material in single cross sections, while lengthening. The shape of lengthening cavities is in the Figure 1.

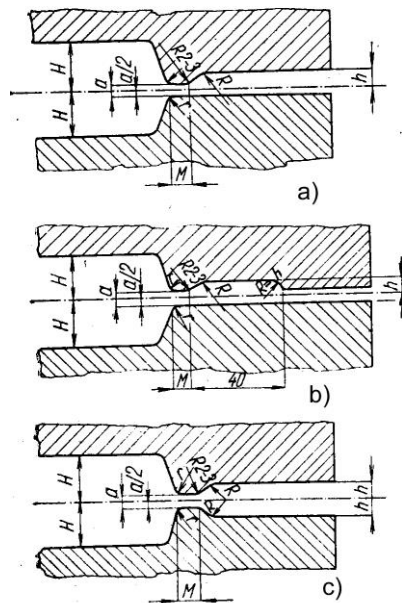

1. Die cavities :

a) roller, b) forming cavity, c) finishing cavity

The height of the cavity is calculated from the relation (8.1), the width b of the cavity should be by about 20 mm wider than the side, or the projection of an initial semi-product.

$$h = (0,8 \text{ až } 0,9) \sqrt{S_{\min}} \quad (8.1)$$

where h is the height of a cavity [mm]

S_{\min} is the smallest cross section of a rough forging [mm²]

Finishing cavities are completely filled by the metal (the closed cavity in Figure 2b) or they are slightly overfilled by a metal (the open cavity in Figure 2a), the excess metal is extruded in the dividing plane of the forging to a flash groove. The flash shall be trimmed / cut off on a trimming tool.

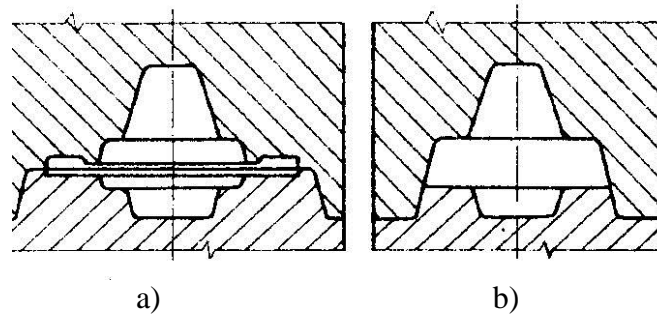

Fig. 2. Finishing die cavities: a) open, b) closed

The largest material loss from the total material losses during drop forging is caused by the flash. Depending on the complexity of the shape of the forging it is around 8-30% by weight of the forging. This disadvantage is however completely offset by positive effects of flash on the course of forging:

1. Thanks to its shape, especially small thickness and large width, it increases resistance to leakage of metal from a die cavity. This creates a favourable state of stress (space compressive stress), which supports the complete filling of the cavity.
2. The flash can equalize volume differences of an initial semi-product (their size depends on the method of manufacturing of an initial semi-product and its dividing before forming), and even the volume differences between the semi-product and a die cavity whose volume increases gradually due to wear;
3. The flash absorbs shocks arisen at mutual fitting closely of individual parts of a die when the die is dynamically loaded at the drop forging carried out on impact forming machines.

Material loss in the flash and its subsequent removal by trimming can be excluded by forging in closed dies (flashless forging), but it is technologically more demanding, mainly due to:

1. It is used only for axisymmetric forgings,
2. Increased demands on precision of dividing of an initial semi-product,
3. Volume deviations of an initial semi-product cause fluctuations of the forging height dimensions,
4. Higher scrap rates due to insufficient filling of forging cavities,
5. Forgings may have a frontal burr which must be removed by grinding,
6. Greater load of a die requires more robust die tool design

8.1 Initial semi-products

For the production of closed die forgings there are used semi-products prepared by hot rolling, for example:

- square steel blocks (ϕ 140 to 300 mm),
- square steel billets (ϕ 40 to 130 mm),
- round billets (ϕ 50 to 290 mm),
- round bars in a standard workmanship version (ϕ 50 to 210 mm),
- round bars in the precise workmanship version (ϕ 50 to 160 mm),
- square rods (ϕ 30 to 150 mm).

Initial semi-products are supplied to forges in commercial lengths (2 to 12 m). Initial semi-products can be divided into shorter batch semi-finished products (blocks, blanks). Their weight corresponds to the weight of the initial semi-products for the given forging. Rod semi-products are divided before forging with the exception of those cases where the division is an integral part of a technological process of forging on the metal forming machine (e.g. forging from the bars on horizontal forging machines). The following methods are used for dividing rod semi-products: cutting, shearing and breaking.

8.2.1 Cutting

By cutting some rod semi-products can be divided on various saw machines. The semi-products can be also cut by oxy-acetylene flame. This method is however recommended for semi-products of larger sections.

Cutting on saw machines is used mainly for non-ferrous metals and alloys that can not be split by shearing. Their low strength leads to undesirable pressure marks on the end portions of cut semi-products. On saw machines the rod semi-products of high-carbon and alloy steels, respectively of common structural steels but with large cross sections are cut. It is the cold cutting. The strength of cut material is $R_m < 900$ MPa.

In the spot of cutting some material waste occurs. Its amount is given by a cutting tool thickness (1 to 8 mm). In comparison with other methods of separation cutting is characterized by low performance efficiency and high consumption of cutting tools, simultaneously however there is excluded any deformation of a semi-product being cut, and there is also ensured top quality of cutting surface, its perpendicularity to the longitudinal axis of a semi-product and minimal dimensional deviations of the length of cut-off semi-products. It is used successfully at parting of semi-products for precise die forgings, for forgings forged in closed dies as well as for upset forgings. In today's forges there high-speed saw machines are used on which it is possible to cut simultaneously up to 30 bars with diameters up to 60 mm.

The frame saws (the length of saw blades from 300 to 700 mm, the width 1 to 3 mm) provide a smaller offcut, however with detriment to low cutting speed and a possible bevelling of a cutting surface. Frame saws with their blade thickness of 1.8 mm are used namely for parting non-ferrous metals thanks to obtaining a higher quality of a cutting surface and for a lower offcut.

The most perfect cutting surfaces can be obtained on circular saws with disc diameters 200 to 800 mm and thickness from 3 to 8 mm. Smaller discs (up to the diameter of 300 mm) are compact, larger discs have inserted teeth, either separately or in segments, and the disc is of carbon steel, segments of high-speed steel. The cutting time shall be calculated as follows:

$$t = \frac{s_o}{p_z n z} \quad (8.2)$$

where s_o is the thickness of a cut rod [mm],
 p_z – spacing of teeth [mm]; $p_z = 0.05$ (hard steel) to 0.2 (mild steel),
 z – number of teeth of a rotary saw ,
 n – speed of rotary saw [min^{-1}].

Considerable reduction of cutting time is reached on friction disc saws and electro-mechanical saw machines which are not used in forges generally. The electro-spark and laser cutting are very promising methods, too.

8.2.2 Shearing

Shearing is a very efficient method of parting of rod semi-products, because on the spot of a shear no waste is produced. In spite of the disadvantage in the form of insufficient quality of shearing surface (it is not absolutely even and perpendicular to the rod longitudinal axis) it is the most widespread method of parting of rod semi-products, Fig. 3.

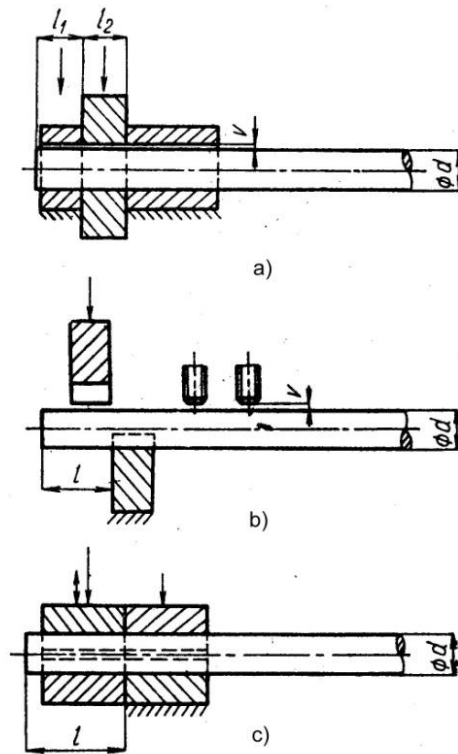

Fig. 3. Shearing methods

a) for two blocks simultaneously, b) open shear, c) closed shear

By shears it is possible to shear steel rods with the thickness of $s_0 > 15$ mm. The shortest length of a cut semi-product l_0 is due to the thickness s_0 limited by the relation:

$$l_0 \geq 0,6s_0 \quad (8.3)$$

On crank presses, in fixtures, there are sheared steel rods with small thickness ($s_0 < 40$ mm) to semi-products of the length:

$$l_0 \geq 0,3s_0 \quad (8.4)$$

The overwhelming majority of low-carbon and low-alloy steels with the strength of $A_m < 600$ MPA and thickness of $s_0 < 150$ mm is cold sheared. In some cases the rods of low-carbon steel are warmed up to the temperature of 300 °C, (to hot brittleness state) for easy shearing without large bruises and convenient appearance of a shearing surface. To the same temperature the rods of mid carbon steels with a large thickness ($s_0 > 120$ mm) are heated to decrease the shearing force.

High-carbon alloy steels shall be heated to temperatures $t > 300$ °C. Like that the shearing force decreases and it is prevented cracking when shearing. There are usually selected

temperatures from 300 to 400 °C in dependence on the steel chemical composition and the rod thickness.

The shearing force when using shears shall be determined on the basis of the following relation:

$$F = k R_m S \quad (8.5)$$

where F is the force [MN]

k is a coefficient covering dulling of cutter and mutual relation of shear strength and tensile strength of sheared material; $k = 1.02$ to 1.36 ,

R_m it is tensile strength at the shearing temperature [MPa],

S is a cross section of a semi-product [m^2].

The force for shearing in fixtures on crank presses shall be also calculated according to the relation (8.5). Considering the greater working speed of crank presses it is increased by 10 to 20 %.

Besides the nominal force there is another characteristic quantity, that is, the largest sectional surface of the rod semi-product with $R_m = 440$ MPA that can be sheared by the given shears. If this surface is designed as S_{ml} (contractual), then the sectional surface of the rod of the material with R_m higher or lower than 440 MPA shall be calculated as follows:

$$S_o = 440 \frac{S_{ml}}{R} \quad (8.6)$$

And the rod thickness shall be determined with the aid of the relation:

$$s_o = 21 \frac{S_{ml}}{\sqrt{R_m}} \quad (8.7)$$

Where S_{ml} is the largest thickness of a contractual rod with $R_m = 440$ MPa that can be sheared with the given shears (mm).

8.2.3 Breaking

Breaking is set up on concentration of stress occurring at bending a body provided with a cut (Fig. 4). The stress concentration at the cut root can cause a drop of plasticity, and even a brittle failure of metal. The crack initiated like that is dispersed with speed up to $1,000 \text{ ms}^{-1}$.

By breaking it is possible to break rod of the thickness $s_o = 70$ to 300 mm, slenderness $l_o/s_o > 1,2$ of the steel of a higher strength ($R_m > 700$ MPa). Among qualities of breaking that are carried out in cold state on crank, eccentric and hydraulic presses there are a lower energy intensity compared with shearing, high production rate and simultaneous checks of the material quality according to the appearance of fracture surface which however is not ideally even.

Cuts shall be made with saws or with an oxy-acetylene torch. The cut width b is according the thickness of a rotary saw; at a torch $b = 6$ to 8 mm. The cut depth:

$$\Delta s_o = k^3 \sqrt{s_o} \quad (8.8)$$

Where k is a coefficient dependent of the steel plasticity; $k = 1$ to 2 , lower values are selected for a steel with a lower plasticity.

Larger depth of a cut decreases the energy intensity of breaking however the quality of the fracture surface is worsened. The force required for a rod breaking can be calculated as follows:

$$F = k s_o^3 \frac{R_m}{l_o} \quad (8.9)$$

where F is the force in [MN]
 l_o is the length of block [m]
 s_o is the thickness [m]
 k is a coefficient of a shape (for circular section $k = 0.16$ to 0.36 , for square section $k = 0.28$ to 0.63).

8.2.4 Accuracy of parting

Accuracy in length of single semi-products depends on dimensions of their cross section and on the method of their parting. For example when shearing by shears the end draft can cause the maximum deviation increasing in length by 1.5 to 2 mm, the end stop movement due to the rod impact by 0.5 to 1.0 mm, the rod deflection from the horizontal position by 0.5 to 0.8 mm and the rod rebound from the end stop can cause a semi-product shortening.

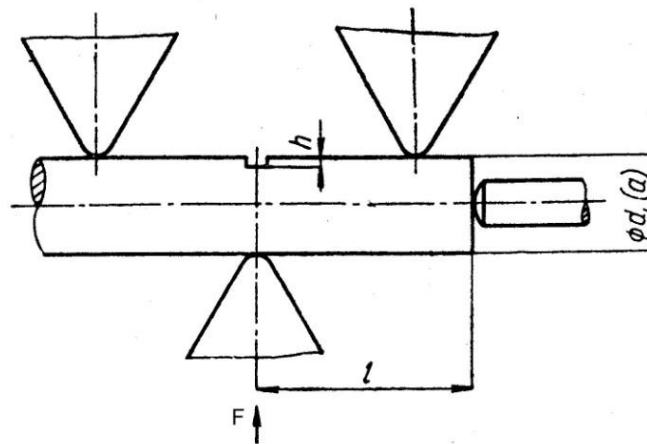

Fig. 4. Scheme of rod semi-products breaking

Depending on single methods of dividing the maximum deviations in length reach the following sizes (mm):

Cutting on saws	± 0.25 to	± 0.75
Electro-spark cutting	± 0.1 to	± 0.25
Anode-mechanical cutting	± 0.1 to	± 0.5
Shearing on shears	± 1.0 to	± 5
Shearing in fixtures	± 0.3 to	± 0.75
Breaking on breakers	± 1.0 to	± 3

Deviations in length together with deviations of cross sectional dimensions of rolled semi-products result in that fact that weights of individual semi-products may differ by 4.5 to 9% ,

which impedes expanding methods of precision forging, and namely forging in closed dies. There are two ways of reduction of deviations in weight:

1. To order the initial semi-products of improved dimensional accuracy, which is connected with considerable price rises.
2. To equip the most widespread dividing machine (shears) with sorting and batching equipment by which the position of the end stop shall be adjusted automatically according to the real sectional dimension of a rod in such a manner to reach the constant weights of sheared semi-products for the given forging.

8.3 Drop forging on power hammers

Forging on hammers ranks among the most widespread methods of drop forging. It is used for manufacture of small and mean series of products and for forging of very asymmetrical forgings, articulated in shape and height. They are largely forged in open cavities on hammers of various types as for their construction.

1. Steam and air double-acting hammers with the ram weight of $m_b = 500$ to 25,000 kg, with manual handling, or with semi-automatic or program control, and with frequency of blows/strokes $n_u < 100 \text{ min}^{-1}$ are very advantageous for progressive forging.
2. Drop hammers generate impact force only through the ram free fall ($m_b = 100$ to 2,500 kg, $n_u < 70 \text{ min}^{-1}$). This factor however limited their use for manufacture of forgings simple in shape in the only one die finishing cavity. As a more perfect type there are chain hammers ($n_u < 100 \text{ min}^{-1}$) which are suitable even for progressive forging thanks to their program control.
3. Counterblow forging hammers with their impact force $W = 50$ to 450 kJ (exceptionally up to 1,000 kJ) are destined for single-cavity die forging of heaviest die forgings. Considering the low frequency of blows ($n_u < 50 \text{ min}^{-1}$) they are characterized with a lower production rate.

8.3.1 Characteristics of drop forging on power hammers

Metal flow at forging on hammers is influenced with a high impact velocity of a ram (up to $9 \text{ m} \cdot \text{s}^{-1}$) and with gradual filling of die cavities thanks to several consecutive blows. Impact character of forging supports the scale releasing from the surface of the formed semi-product and directs the flow of metal into the top part of the die, where should preferably be placed high lugs and thin ribs of the forging. More intensive filling of the die top part is attributed to a very short contact time (of the order of hundredths, sometimes thousandth of a second) of the top part of the die with the formed metal which is then less cooled down and has a lower resistance to deformation. The final shape of the forging is obtained in the single-cavity die forging or in several cavities.

The single-cavity forging is chosen for large and heavy forgings (Fig. 4)

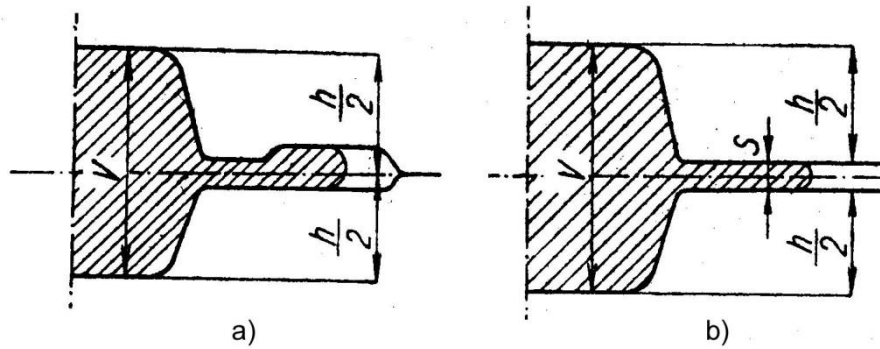

Fig. 4. Single-cavity die

8.3.1.1 Power hammer dies

The impact force effect is also respected in the design of dies and their clamping. Dies are mostly made of solid, robust blocks. Their size is determined so that the minimum distance \underline{s} was kept and maintained between the edge of the block and the next cavity. When using the progressive forging in a multi-cavities die (Fig. 5), the distance between the cavities is determined by the relation:

$$s_1 = s \cos \alpha_1 \quad (8.10)$$

where α_1 is the lateral draft of a cavity

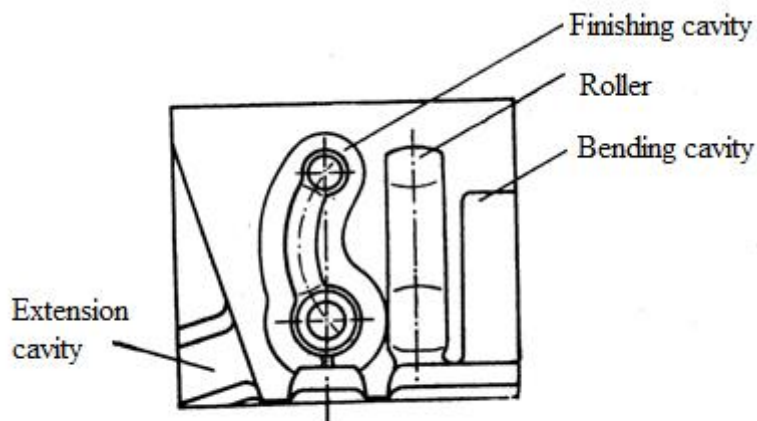

Fig. 5. Arrangement of die cavities in the die block

The minimum height of the die H_z shall be determined on the basis of the maximum depth of the die cavity H_d as follows:

$$H_z \cong 2,15 H_d \quad (8.11)$$

where H_z is the height of the die bottom part [mm]

H_d is the cavity depth [mm]

Due to different service life of die cavities and uneven stress on the individual parts of the cavity the die inserts are used. These are able to reduce the material costs of making dies. The

inserts are clamped into the die block by a wedge or they are built-in with an overlapping in the cold state that send cold overlapping (Fig. 6).

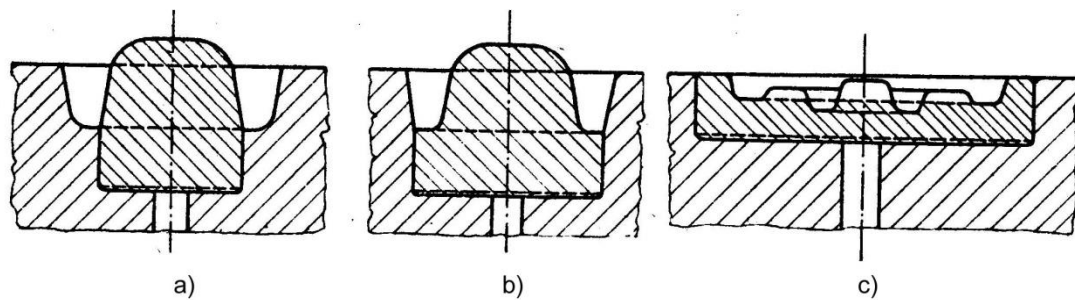

Fig. 6. Die inserts

In order to ensure perfect fitting of both parts of the die and thus the smallest offset of the forging, the die is provided with different kinds of guides (circular, longitudinal, transverse and cross), guide pins or locks for taking up the shear forces.

To achieve the final shape of the forging there are used finishing cavities. The shape of finishing cavity is identical to the shape and the dimensions of forging differ only by difference of the material shrinkage from the forging temperature to the ambient temperature. Around the finishing cavity a flash groove is formed in the dividing plane. The shape of the flash groove is in the Figure 7. The shape (a) consists of a bridge and a tray that is placed in the upper die (due to trimming). In the cavity part where a larger excess of the material is assumed a double-side tray is available (the shape B).

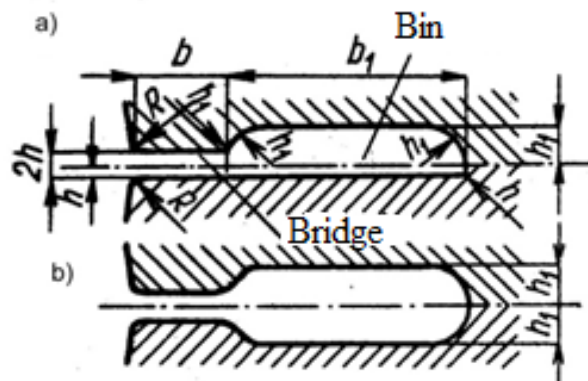

Fig. 7. The shape of flash groove

The bridge thickness h can be calculated from the following relation:

$$h_m = (0,012 \text{ až } 0,015) \sqrt{S_v} \quad (8.12)$$

where S_v is the area of the horizontal projection of forging (mm^2), other dimensions shall be chosen from the tables.

The die is provided by a dovetailed lug (Fig. 8) by which it is placed into a dovetail clamping groove of the ram or into a fireclay liner stabilized with the aid of a wedge with a draft 1 : 100. As for counterblow forging hammers there are dies clamped by two wedges.

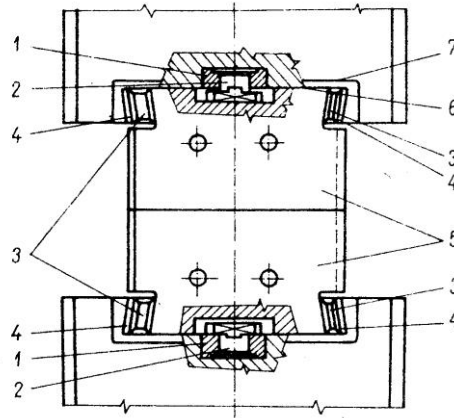

Fig. 8. Die clamping on the counterblow forging hammer
 1 – securing pin bush; 2 – securing pin; 3 - wedge; 4 – wedge gib; 5 - die; 6 - dovetail; 7 – clamping groove

Questions:

1. What shapes of die cavities do you know?
2. How calculate the shape and dimensions of a flash groove?
3. What accuracy is achieved with single methods of parting semi-products before forging?

Tasks to solve:

1. Calculate waste losses for single methods of parting.
2. Deduce a relation for calculation of a force for shearing by shears for shearing the rectangular section: 70 x 50 mm. The semi-product is of steel i 42CrMo6.:

9. TECHNOLOGICAL PROCEDURE FOR DROP FORGING

Chapter contents:

- Construction of a closed die forging
- Cavities choosing
- Ideal rough forging



Time needed for studying: 120 minutes

Aim: After studying this chapter

- You will be able to determine a shape and dimensions of a forging
- You will learn to establish forging procedures
- You will be able to construct an ideal shape of a rough forging



Explication

9.1 Construction of closed die forging

When designing technological process is necessary to solve:

1. Shape and dimensions of a closed die forging,
2. Choice of forging cavities,
3. Choice of an initial semi-product,
4. Calculation of a ram weight.

The shape and dimensions of a closed die forging shall be determined on the basis of a drawing of the finished product. By direct cooperation between the forge's technologist and a designer of the finished product its shape can be adjusted. This simplifies the technological procedure of forging. And further, it is necessary to consider, whether it is expedient and rational:

1. To make the given product by closed die forging or use another, more advantageous technology
2. To unify the forgings to finished products similar in shape and dimensions,
3. To part a complex product to two more simple ones that can be forged easier, with a lower material consumption and welded together subsequently (Fig. 9.1),
4. To forge two identical products as the only one forging and part them subsequently (Fig. 9.2),

5. To replace further machining by more accurate punching procedure,
6. To forge the given product on another, more suitable metal forming machine.

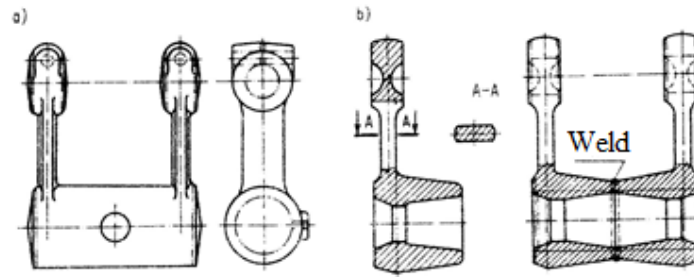

Fig. 9.1. Two variants of making the same component:
a) by forging in one piece b) by welding from two forgings more simple in shape

Significant importance for the design of a die forging has a parting line, which shall be placed in the plane of symmetry of the forging (if that's even possible) or in the plane of two largest dimensions of forgings a, b (Fig. 9.2) being perpendicular each other. That rule may be waived in cases when reducing the weight of the forging (Fig. 9.2 - 1 ') by otherwise designed parting plane or by reducing a flash weight (by reducing the circumference) while simplifying the design of trimming dies (Fig.9.2-2'), or simplifying the forging technology, e.g. by deletion of bending (Fig. 9.2 - 3 ').

When designing the parting plane the intensified metal flow into the upper part of the die must be also taken into account to achieve a suitable course of the fibres, and the reliable check of fitting together of upper and lower part of the die, and easy flash trimming shall be monitored too.

Machining allowances, rounding of edges and corners, minimum wall thickness of the forging, the smallest thickness of the bottom (membrane) forgings, as well as any deviations in shapes and sizes (dimensional tolerances, offset, burr sizes, lateral drafts, deflection) of forgings are normalized.

When designing a closed die forging the accuracy of workmanship, which is closely associated with dimensional tolerances of forging, must be taken into account. According to the standard the forgings shall be manufactured:

1. with the usual accuracy,
2. in a precise finish workmanship (with a higher accuracy),
3. in the very precise finish workmanship (with the accuracy according to the agreement).

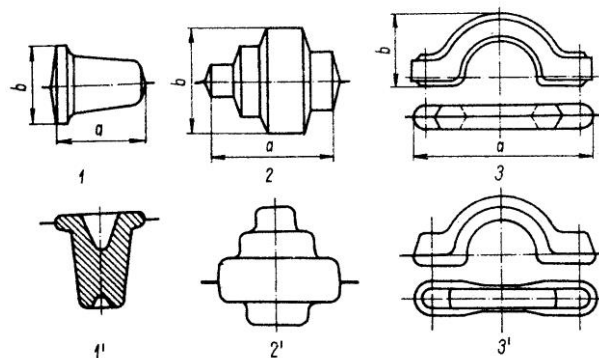

Fig. 9.2. Examples of parting plane

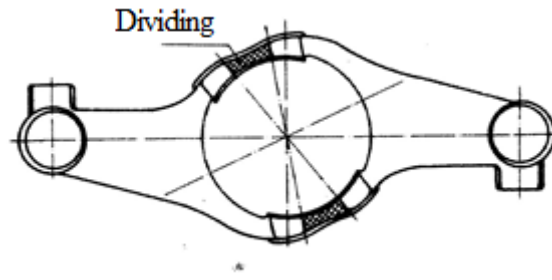

Fig. 9.3. One forging for two identical parts

9.2 Choice of forging cavities

A part of the assortment of drop-forged forgings is made by single-cavity die forging which is reasonable for the forgings:

1. of a simple shape, without the need of rough forging,
2. heavy and large ones being forged on counterblow forging hammers,
3. in small batch production, when the purchase of an expensive multi-cavity die is not economical,
4. extremely complicated in shape, when it is more advantageous to manufacture rough forgings with using open die forging.

With most closed die forgings a rough forging is obtained progressive forging in several forging cavities which are selected by the shape features of a forging, according previous based on experience with forgings of similar shapes or according to other recommendations. By increasing the volume of moved metal and the complexity of the metal flow during forging of the longitudinal forgings it is possible to compile the sequence of the most common preparatory cavities and their combinations as follows:

1. necking,
2. open parting
3. closed parting,
4. lengthening,
5. lengthening – open parting,
6. lengthening – closed parting.

9.3 Ideal rough forging

If a forging is forged by the method of progressive forging it is necessary to made a rough forging in preparatory cavities whose cross-section would be close to the sum of the corresponding cross sections of forging and a flash. In practice, there is used the procedure of determining of the so-called ideal rough forging, which is an axisymmetric body having a volume V_{ip} equal to the volume forging V_v enlarged by the volume of the flash V_r and which length l_{ip} is equal to the length l_v of the forging. For forgings with a straight axis it is constructed according to a forging drawing, for forgings with a bent axis according to their developed length. Through a considered forging a network of cross sections is led, whose density depends on the complexity of the forging shape. In typical cross sections of the forging S (in the Figure 9.4a they are marked as $S_1, S_2, S_3, S_{min}, S_{max}$) content of a sectional area of the ideal rough forging S_{ip} is calculated, separately for non-end sections:

$$S_{ip} = S + 2S_{vr} \quad (9.1)$$

And separately for end sections,

$$S_{ip} = S_{vr} \quad (9.2)$$

where S_{vr} is a surface area of a forging $[\text{mm}^2]$.

The diameter of an ideal rough forging in an arbitrary cross section:

$$d_{ip} = 1,13\sqrt{S_{ip}} \quad (9.3)$$

The calculated values d_{ip} are plotted symmetrically as coordinates from the selected horizontal axis in the Figure 9.4b. By connecting the endpoints of the ordinates there is created an outline of ideal rough forging. By marking the values of surface areas of characteristic sections S_{ip} at the scale m as ordinates in height:

$$h_{ip} = \frac{S_{ip}}{m} \quad (9.4)$$

and by connecting the endpoints of these ordinates a cross-sectional shape of an ideal rough forging can be reached (Fig. 9.4c).

Then the ideal rough forging shall be transformed (reduced) to a reduced ideal rough forging, which is a cylindrical body of the diameter d_{red} and length of l_{ip} . For its volume V_{red} , the cross section S_{red} and the diameter d_{res} the following is valid:

$$V_{red} = V_{ip} = S_{red}l_{ip} \quad (9.5)$$

$$d_{red} = 1,13\sqrt{S_{red}} \quad (9.6)$$

The part of a rough forging in which the $d_{ip} > d_{red}$ is called the head/ top, the part where $D_{ip} < d_{red}$ is called a stem. The ideal rough forging having one head and one stem is called the basic elemental ideal rough forging. If the ideal rough forging has a head between the stems, or has two or more heads, it is a complex ideal rough forging, which can be transformed to a basic elemental ideal rough forging by relatively simple procedure.

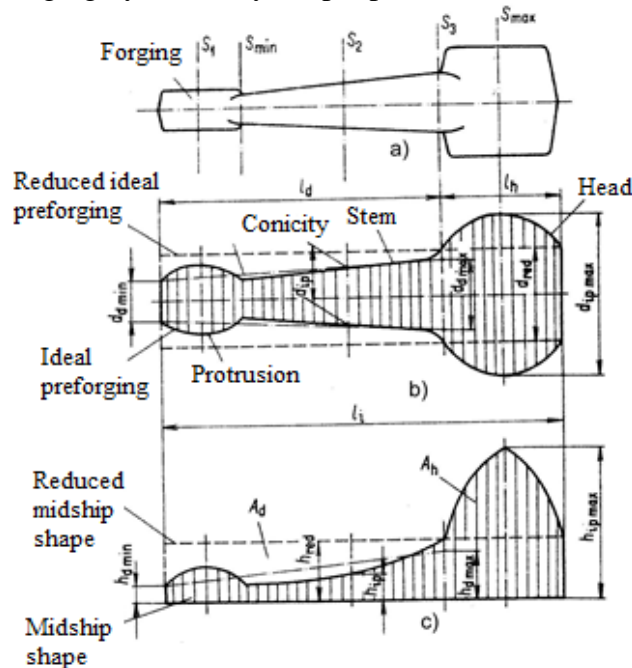

Fig. 9.4. Procedure of designing an ideal rough forging
a) Forging b) ideal rough forging, c) sectional outline

On the sectional outline its height h_{red} shape defines appropriate, each other equal areas of excess material A_h (in the head) and missing material A_d (in the stem). Due to the characteristics of the sectional outline the area A_d is excess volume of material in the stem, which must be movable with the aid of the preparatory cavities to the head/top where the material is lacking.

If with a forging with a hole or a recess (Figure 9.5A) the head of an ideal rough forging has a shape with sharp transitions (Figure 9.5b), it is necessary to adapt that head (see the dashed outline in the Figure 9.5b), while maintaining its volume. The suggested adaptation is preferably carried out at a sectional outline (Fig. 9.5c), however the following shall be met:

$$A_1 + A_2 = A_3$$

The conicity of a stem can be expressed by the relation

$$k = \frac{d_{dmax} - d_{dmin}}{l_d} \quad (9.7)$$

where d_{dmax} is the largest diameter of the stem [mm], d_{dmin} – is the smallest diameter of the stem (mm), l_d is the length of the stem [mm].

A more complex shape of the stem shall be modified to a truncated cone that shall be projected to a front elevation as a trapezoid with bases h_{dmax} , h_{dmin} and l_d . With the aid of planimetry its surface S_d shall be defined:

$$h_{dmax} = 2 \frac{S_d}{l_d} - h_{dmin} \quad (9.8)$$

The design of an ideal rough forging allows you to calculate the necessary parameters (α , β , k) to select the initial preparatory cavity, using the Figure 9.3.

More detailed information on the method of ideal rough forging design, taking into account the complexity of the forging shape, contains the literature.

Cavities and their combination can be selected from the diagram in the Figure 9.3, the practical application of which is possible after designing the so called ideal rough forging (Fig. 9.4),

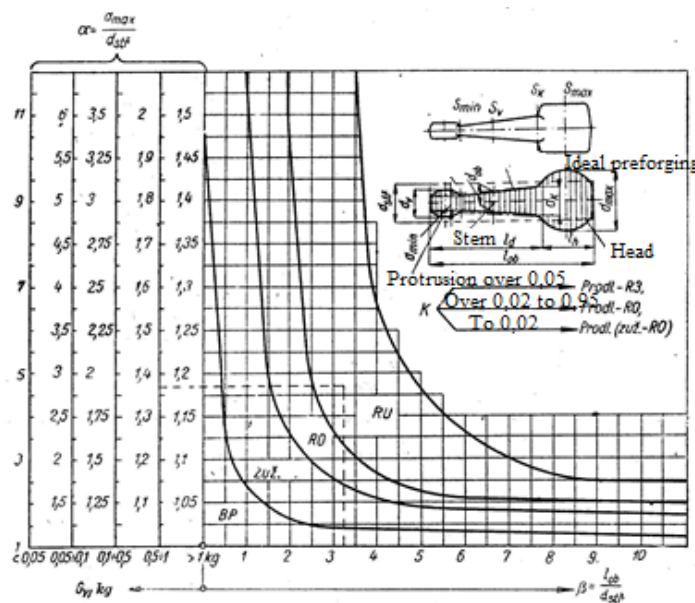

Fig. 9.3. Diagram for determining preparatory cavities (m_v – forging weight)

9.3 Choice of initial rough forging

Small forgings are usually forged of metal rod blanks with the length of $l = 1,200$ mm and a weight up to 5 kg. The finished forgings are gradually cut through from the remaining rod by an anvil chisel, Figure 9.6.

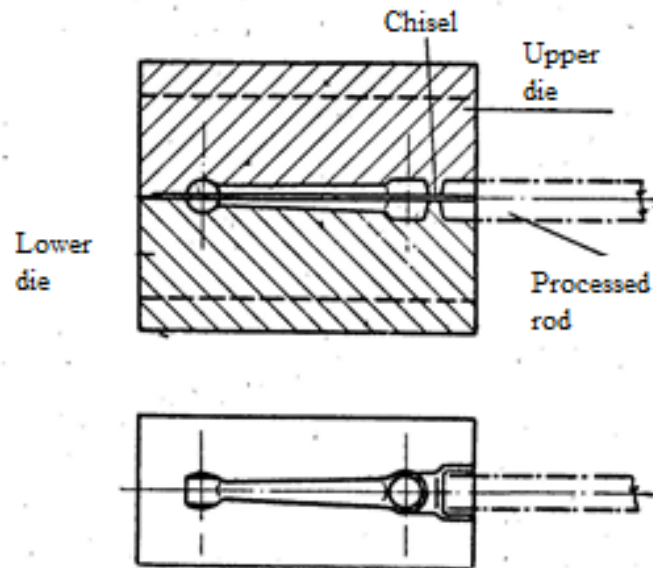

Fig. 9.6. The die for forging of rod materials

Smallest forgings are forged simultaneously in multiple pieces connected by a flash, Figure 9.7.

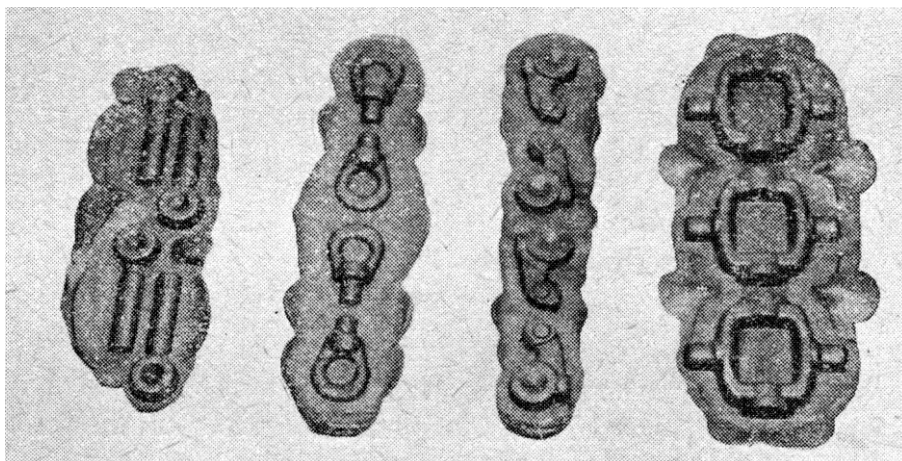

Fig. 9.7. Forging in multi-cavity die

Medium-size forgings are forged from an initial rough forging destined for two forgings, so that after finishing forging of the first forged piece the already processed rough forging should be turned over and then its remaining part can be forged. The neck connecting these two forgings shall be cut in two by the anvil chisel.

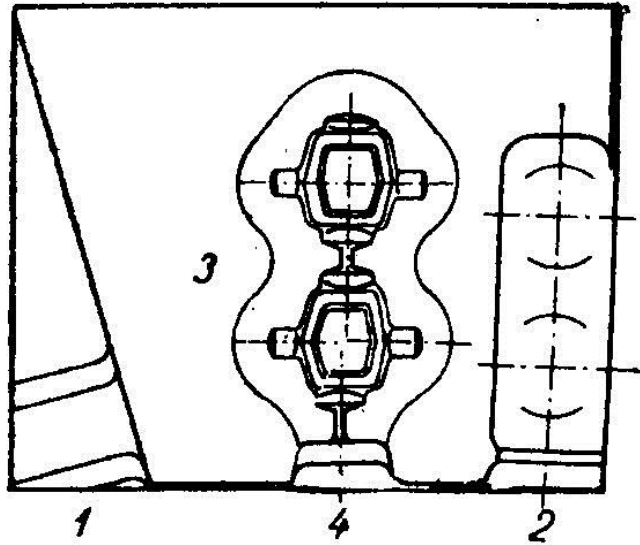

Fig. 9.8. The die destined for double-piece forging
1, 2 – rough forging cavities, 3 – finishing cavities, 4 – anvil chisel

Large forgings and upset forgings shall be forged individually from the only one initial semi-product.

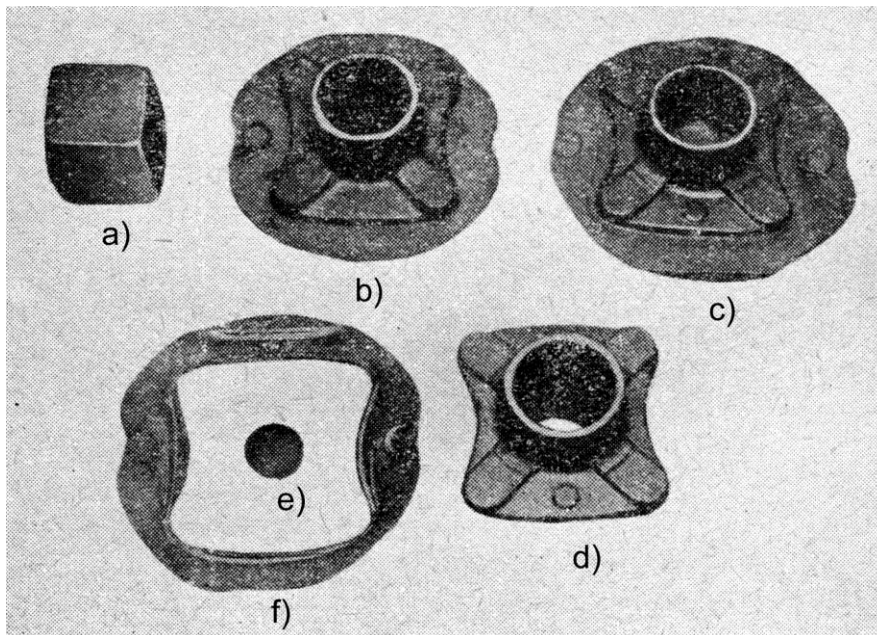

Fig. 9.9. Procedure for wheel hub forging
a) initial semi-product, b) rough-forging, c) forging with a flash, d) forging, e) punching body flash, f) trimmed flash

At forging with a more complex shape it is necessary to take into account a technological allowance for a grip, Fig. 9.10.

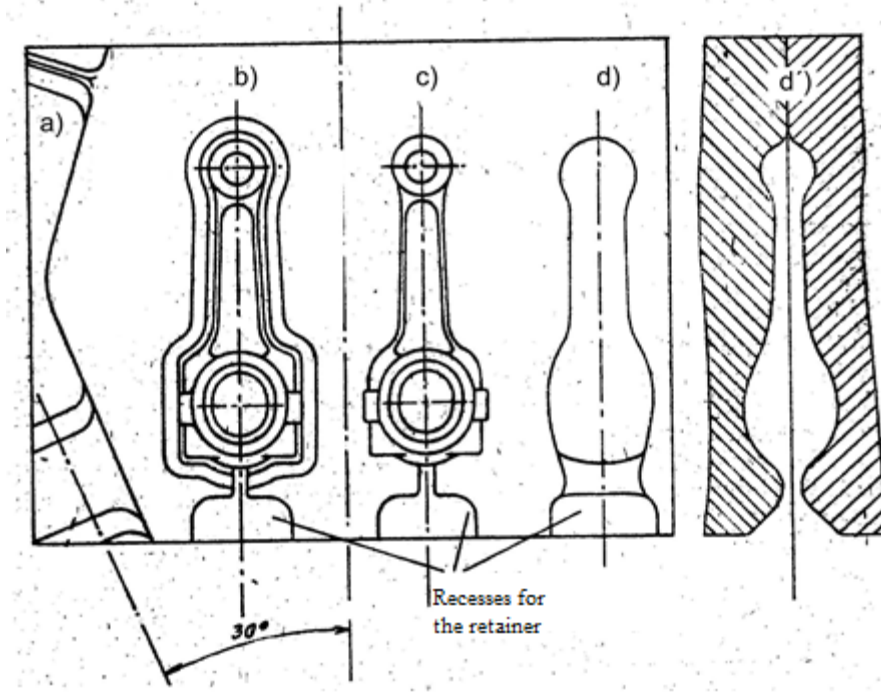

Fig. 9.10. The die for progressive forging of connecting rods

The choice of basic methods of forging according to the weight m_v and the length of forging L_v can be facilitated by the in the Figure 9.11.

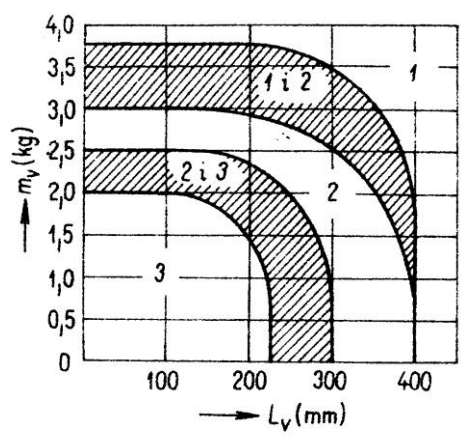

Fig. 9.11. The diagram for a choice of an initial semi-product according to the method of its forging:

- 1 – forging of individual forgings; 2 – forging of two forgings with turning-over; 3 – forging from a rod semi-product

For the volume of an initial semi-product the following is valid:

$$V_o = V_v + V_z \tag{9.9}$$

where V_v is the volume of a forging [mm³],

V_z – volume of all material losses accompanying heating and forging [mm³].

If we mark the volume of a flash as V_{vr} , the volume of a punching body flash (waste due to punching) V_{vd} , the volume of a grip V_u and the volume of a burn-off V_o , then

$$V_z = V_{vr} + V_{vd} + V_u + V_o \quad (9.10)$$

The volume of a flash shall be calculated from the relation

$$V_{vr} = (0,6 \text{ až } 0,8) S_{vrd} O \quad (9.11)$$

Where S_{vrd} is a cross section of flash groove [mm²],

O is a circumference of a forging in the parting plane [mm].

The volume of a punching body flash V_{vd} and a grip V_u shall be calculated according to their dimensions, for the volume of a burn-off V_o it is valid,

$$V_o = V_v \frac{1}{1 - \frac{o}{100}} \quad (9.12)$$

where o is a burnt-off (%), can be chosen with the aid of the Table 9.1.

Table 9.1. Losses due to a burnt-off with various methods of heating

Method of heating	Burnt-off o (%)
Chamber gas furnace	2.5 to 3
Chamber electric furnace	1 to 1.5
Induction and resistance heating	0.5 to 1

If for the basic shapes of forgings it is valid that $V_{vd} = 0$ and $V_{uu} = 0$, then the relation destined for the calculation of an initial semi-product will be as follows:

$$V_o = \frac{V_v}{1 - \frac{o}{100}} \quad (9.13)$$

The shape and dimensions of a cross section of an initial semi-product depend on the type of the first forging cavity into which the semi-product shall be inserted. As for an upsetting cavity is considered there is necessary to limit the slenderness of an initial semi-product to $s_o \leq 2,5$. So, for the thickness of an initial semi-product it is valid:

$$t_o = k \sqrt[3]{\frac{V_o}{s_o}} \quad (9.14)$$

where k is a shape factor; for the square cross section $k = 1$, for the circular section $k = 1.08$.

Table 9.2. Calculation of the cross section of an initial semi-product S_o for various types of forging cavities

Forging cavity	Formula for calculation	
1. Finishing.	$S_{o1} = (1.02 \text{ to } 1.05) S_{red}$	$[\text{mm}^2]$
2. Necking or shaping	$S_{o2} = (1.05 \text{ to } 1.3) S_{red}$	$[\text{mm}^2]$
3. Parting	$S_{o3} = (1.02 \text{ to } 1.2) S_{red}$	$[\text{mm}^2]$
4. Lengthening	$S_{o4} = V_h/L_h$	$[\text{mm}^2]$
5. Lengthening and parting	$S_{o5} = S_{o4} - k(S_{o4} - S_{o3})$	$[\text{mm}^2]$

S_{red} is the surface area of a cross section of a reduced ideal rough forging (mm^2),

V_h is the volume of an ideal rough forging top/head (mm^3),

L_h is the length of an ideal rough forging top /head (mm),

k is a taper ratio of a stem of an ideal rough forging.

For other cavities the surface of a cross section of an initial semi-product shall be calculated according to the Table 9.2.

The length of an initial semi-product shall be determined according to the relation:

$$L_o = \frac{V_o}{S_o} \quad (9.15)$$

The example of the technological procedure of a connecting rod forging is in the Figure 9.12

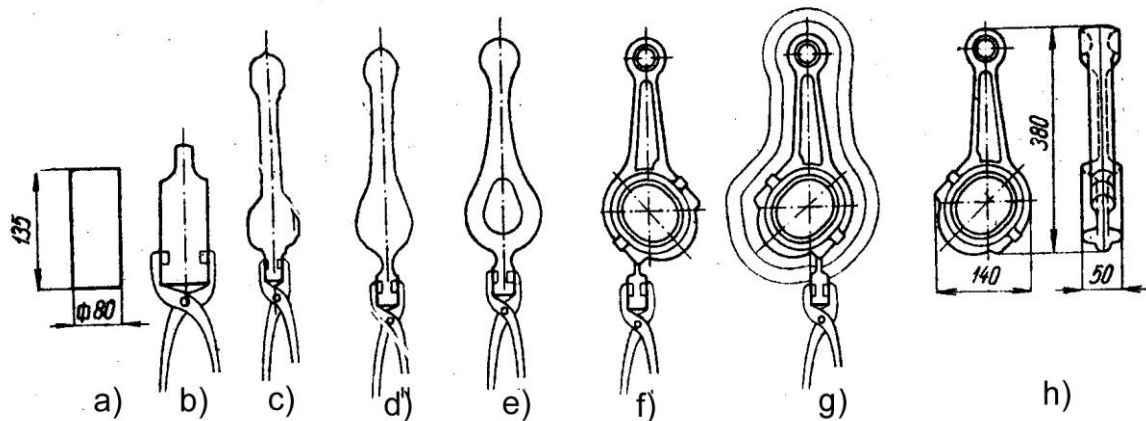

Fig. 9.12. Technological procedure of a connecting rod forging

Weight of a charge: 6.80 kg. Net weight: 4.70 kg.

Machine: Die-forging steam hammer, ram weight 2,500 kg. Tool: progressive die

Procedure of forging: a) initial semi-product, b) forging a grip for pliers, c) forging the stem and a small head off, d) rough-forging in a lengthening cavity, e) large head flattening f) forging in a rough forging cavity, g) forging in a finishing cavity, h) forging after trimming and punching.

9.4 Calculation of the ram weight

The ram weight shall be calculated from the forging final dimensions. For axisymmetric forgings:

$$m_b = 100(1 - 0,5D_v) \left(1,1 + \frac{0,02}{D_v} \right)^2 (0,75 + 10D_v^2) D_v \sigma_p \quad (9.16)$$

where m_b is the ram weight [kg]

D_v is the diameter of a forging in the parting plane [m],

σ_p is a natural deformation resistance [MPa].

For other shapes of forgings there are used the following relation:

$$m_{b1} = m_b \left(1 + 0,1 \sqrt{\frac{L_v}{B_{vs}}} \right) \quad (9.17)$$

where m_b is the weight of a ram according to the relation (9.16),

$D_v = 1.13 S_v^{1/2}$ [m],

S_v is the surface of a horizontal projection of a forging [m²],

L_v is the length of a forging [m]

B_{vs} is the mean width of a forging [m]; $B_{vs} = S_v/L_v$.

Questions:

1. How to proceed when designing a technology of the drop forging?
2. How to determine dimension of an ideal rough forging?
3. According what principles an initial forging for the drop forging shall be choose?
4. What is the procedure for forging the forgings of small weight?

Tasks to solve:

1. Design an ideal rough forging for a forging of a connecting rod. Connecting rod weight

$m_v = 4.5$ kg. Forging dimensions:

$L = 380$ mm, $B_{max} = 140$ mm.

2. Calculate the weight of a ram for forging the above mentioned forging that is of steel, class 12 050. Top forging temperature equals to 1,200 °C ($\sigma_p = 21$ MPA).
-

10. DROP FORGING ON PRESSES

Chapter contents:

- Forging on crank presses
- Forging on screw presses
- Construction of die cavities



Time needed for studying: 120 minutes

Aim: After studying this chapter

- You will be able to determine principles for forging on crank presses
- You will be able to calculate deformation forces at forging in dies
- You will learn principles for designing die cavities



Explication

10.1 Forging on crank presses

The forging method is different from forging on hammers. Hammers work on the principle of a blow and the forging is made from a rough forging by a few blows, or there is used progressive forging. The crank press has a smaller deformation velocity and its stroke is constant. The disadvantage of forging on vertical presses is that scale arising by heating to forging/finishing temperature can be pushed into the forging. So the scale must be removed, or heating shall be used, wherein the creation of scales is minimal however induction heating is used preferably in such a case. When forging on crank presses there shall be applied the principle that at one stroke one operation shall be made in one die cavity.

The vertical forging presses have power from 6.3 to 100 MN. The working speed is about 0.5 to 0.8 ms⁻¹. The top tool performs up to 90 strokes per minute. Characteristics of crank presses:

- static nature of the deformation,
- Accurate guide of the upper tool, limited lower position of the tool,
- The forging is forced out of the cavity of the bottom die by a kick-off.

Due to a smaller metal flow into the upper part of the die higher demands are subject to rough-forging of the forging. The cause of a slowed-down flow is a longer contact time with the top part of the die with a formed metal. When forging on a hammer the contact time of the

tool with the material is around $\tau = 0.0007$ to 0.001 s, on the crankshaft forging presses it is $\tau = 0.03$ to 0.2 s. And simultaneously deformation of the entire volume of a formed metal is realized, and thus a uniform filling of top and bottom part of the die. Preparation of the rough forging for presses is made on a hammer or on forging rolls, respectively there are used periodically rolled semi-products. Forgings being forged on crank presses are classified according to their shape complexity into six basic groups, see the Figure 1.10





I.		Simple, compact components
II.		Compact, little rugged components
III.		Components with a high degree of deformation
IV.		Bifurcated components
V.		Parts of a small thickness and transitions
VI.		Components with extremely small cross-sectional thickness

Fig. 10.1. The grade of the forging shape complexity

Some examples of a technological procedure of forging of a shape-complicated forging (Fig. 10.2a) and a longitudinal forging (Fig. 10.2b) are given in the following Figure.

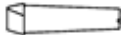
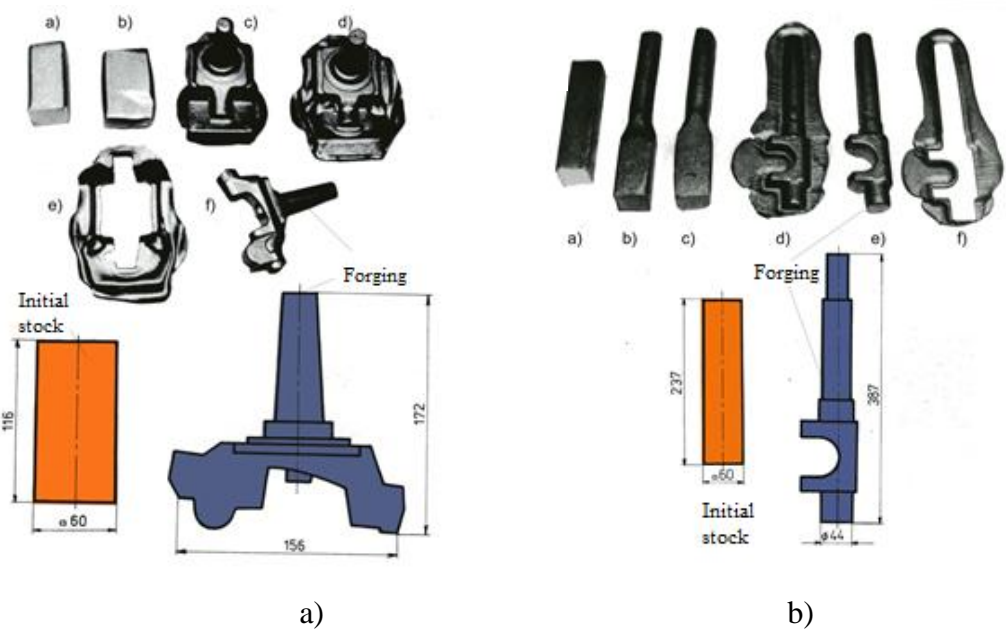

Fig. 10.2. Technological procedure of forging of a shape-complicated and longitudinal forging on a crank press

- When choosing suitable sizes of a vertical forging press it is necessary to consider at first
- dimensions, weight and the forging shape complexity,
- methods of forging and a number of operations being expected.

It is followed by the assessment of technological parameters of a press under consideration:

- nominal force,
- energy of a flywheel,
- output power of an electric motor.

Nominal force of the press is the largest allowed force [MN], by which a press can be loaded during a forming operation. It is the basic technical statement of each press. When operating it is necessary to avoid not permitted loads being above the value of nominal force because overloading reduces the service life of the press and increases the risk of serious damage of the press.

The press frame and crank mechanism/gear of a press can be dimensioned sufficiently for forging of the given forged piece, but if the forging press has insufficient energy of a flywheel or an electric motor of a low power necessary for needed deformation work, there is an excessive drop in the flywheel speed, respectively in extreme cases the ram stopping can happen. It follows that for the ram greater travel and for a faster operation there must be more available energy of the flywheel and there is also needed an electric motor of a higher power output.

The size of the electric motor as for its power is chosen so that a wide range of standard works that may be realized on that forging press would be covered. Other factors are given by the forging itself and by manufacturing methods being used there. And, furthermore, by technological parameters and possibilities of usability of presses.

Determination of a forging force for the given forging is done according to formulas that are only approximate, so they should be used with a caution to avoid misunderstandings. Forging is realized in dies preheated to a temperature of 200-250 ° C and more. At the moment of forging finishing when the formed material is in contact with a die, an intensive cooling-down– the temperature drop, in particular of its thin portions can be observed there.

Extent of temperature drop of the forging in a die is dependent on the ratio of the contact surface of the forging and the die S [mm²] and the forging volume V [mm³]. The greater is S / V , the greater drop in temperature (typically by about 20 to-70 ° C) may happen. To the total temperature drop should be added also the temperature drop in forging during its transfer from one operation to another when forging is realized in several operations. This drop however usually does not exceed 10 ° C. The overall drop in temperature, or finishing temperature, must be considered when determining the deformation resistance σ_s of a forged material when calculating the force needed for forging of the given forged piece.

The value of the deformation resistance σ_s [MPa] is affected – besides the material quality - also the deformation velocity. The deformation extent is included in degrees of the forging shape complexity. Another parameter for determination of forging force is:

- the area of the forging projection including a flash bridge to the plane of forging S_v [mm²]
- the ratio of the flash bridge width to its thickness b/s . The ratio b/a is chosen $\max = 3$.

To determine the thickness of the flash s [mm] the forges in practice use nomograms, as well as for the determination of a forging force.

10.2 Drop forging on screw presses

Screw presses are universal forming machines. Their advantages are especially appreciated in small batch production with diverse and variable production program, where they replace a number of other, mostly single-purpose machines. They are used to forging in open and closed dies, in dies with vertically split lower part, for straightening, punching, bending, lengthening and calibration.

They have a deformation force of 25 MN in a classic double-disc version and the force up to 63 MN in hydraulic workmanship versions. Low working speed from 0.5 to 0.9 m s⁻¹, is similar to the crank forging presses, but the nature of their work, especially complete depletion of the kinetic energy of the flywheel on every stroke and kinematic independence of the press ram / slide mechanism are alike the hammers.

Screw presses are characterized by long stroke, little solid leadership of the press ram /slide mechanism and the kick-off in the bottom part of the die, sometimes even in the top part of the die. Presses are not suitable for progressive forging and forging of shape-complicated forgings with significant dimensional changes in the direction of impact.

Dies are made out of solid blocks or inserted similarly as hammer dies. With regard to the other clamping methods, however, they are characterized by a more simple shape, without any dovetails. For the remaining constructional elements of the die the same principles as for hammer dies are applied.

A similar procedure is applied when designing a forging, with forging cavity and initial semi-product selection, but with the crucial difference that it is recommended to forge in a single-cavity die by only one blow. Exceptionally the die is provided with more than one preparatory cavity with an undemanding moving the metal, i.e. with an upsetting, bending, forming or necking cavity. The finishing cavity must be always placed in the screw axis. A more demanding rough forging can be used only for screw presses with hydraulic drives. The screw presses do not use lengthening and parting operations. If there is a need of these operations due to construction of an ideal rough forging, they are replaced by rough-forging on another forming machine or by a periodically rolled semi-product.

The deformation force shall be calculated as follows:

$$F = 0,384(1 - 0,5D_v) \left(2 + 0,1 \frac{D_v}{H_{vs}} \right) \sigma_p S_v \quad (10.2)$$

where F is the required force [MN]

D_v is the diameter of a forging in the parting plane [m],

H_{vs} is the mean height of a forging (m); $H_{vs} = V_v/S_v$,

σ_p is a natural deformation resistance [MPa],

S_v is the surface area of a horizontal projection of a forging [m²],

V_v is a volume of a forging [m³].

10.3 Design of die cavities

The necessary prerequisite of successful design of a die is to determine the size of the forging press. In the design of the die it is necessary to respect:

- The bottom position of the press ram is unchanged. The cavity of the die is filled by one stroke of the press (it is not filled by progressive blows as with the hammer).
- The number of cavities in the die must be equal to the number of the press strokes necessary for making a forging.
- The presses are provided with a kick-off equipped with ejector, and therefore bottom die cavities may have smaller draft.

Cavities are not made to die blocks, but to die inserts. The inserts are clamped into the holders. For each operation a separate cavity shall be made. In the design of die inserts the following principles must be followed:

- a) a) The thickness of the edge t should be equal to or greater than the depth of the cavity h
- b) b) If the cavity has a semi-circular shape with the radius r , then the following is valid:

$$t_1 = (0,6 \text{ až } 0,8) h \quad (10.3)$$

- c) Thickness of the bottom s must fulfil the condition:

$$s = (0,6 \text{ až } 0,65) h \quad (10.4)$$

- d) In every die insert there is only one cavity
- e) At the press clamping the press a gap must be between the die upper insert and the lower one which corresponds to the thickness of a flash.

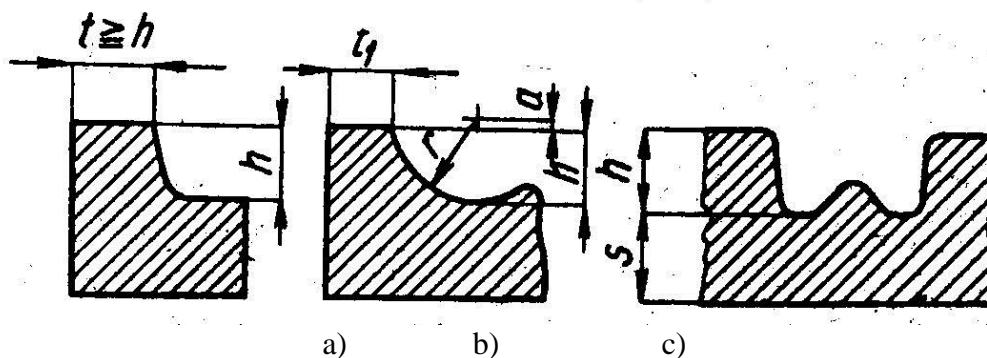

Fig. 10. 3. Design of cavities of die inserts

To achieve the desired dimensions of the forging the shape of a finishing cavity is of great importance. In the design of the finishing cavity there shall be is devoted attention to the shape of a flash groove. The thickness of the flash is dependent on the gap in the parting plane of the die and the elastic deformation of the press frame. Mostly there are used three types of grooves, Figure 3.10.

The most often the type A is used. If a cavity is very far from the edge of the die insert then it is used the cavity type b. The type c is used in cases where in any spot of the rough forging there is a large excess of metal and one-sided groove is not sufficient for its removal.

For a better insertion of a forging into the trimming die a finishing cavity is constructed so that the groove for a flash would be placed in the top half of the die. Another reason is that the bottom part of the die heats up faster than the top one and the bridge heated to a higher temperature shortens the service life of the die.

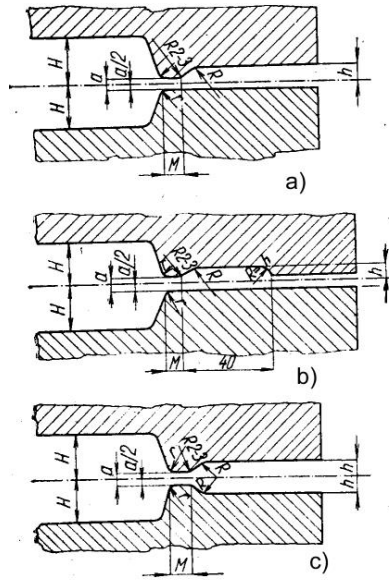

Fig. 10.4. Types of flash grooves

Table 10.1. Basic dimensions of a flash groove for dies on vertical forging presses

F [MN]	a [mm]	M [mm]	h [mm]	R [mm]	H [mm]	r [mm]
6,3	1-1,5	4-5	5	15	1-3	0,5
15	2-2,5	5-6	6	20	8-20	1,5
25	2,5-3,0	6	6-8	20	30-60	3,0
40	3,5-4,0	6-8	8	25	≥ 60	4,0

Annular and pin kick-off mechanisms allow to choose two or three times smaller lateral drafts than they are in the hammer dies and, in some cases (extrusion) it is possible to forge completely without a draft.

Forging construction is governed essentially by similar principles as with forging on hammers. Forgings however, have lesser machining and technological allowances, higher grade of accuracy, smaller lateral drafts, in summary, it is possible to obtain the shape which is very close to the finished product (Fig. 10.4), which leads to savings in metal, and reducing the costs for machining the forging.

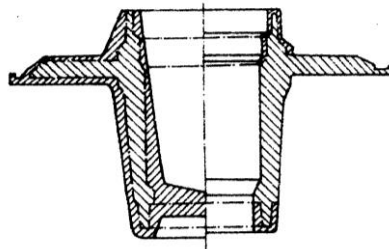

Fig. 10. 5. The section through a forging made on a hammer (left half) and on a vertical forging press (right half)

Procedures of forging and ordination of forging cavities during forging longitudinal forgings on vertical forging presses:

- Initial semi-product,
- Upsetting cavity,
- Extruding, necking, bending, forming cavities,
- Rough-forging,
- Finishing,
- The forging.

Procedures of forging and ordination of forging cavities for forgings with circular or square sections in the parting plane are the following:

- ◆ Initial semi-product,
- ◆ Upsetting,
- ◆ Extruding, upsetting in shape
- ◆ Rough-forging,
- ◆ Finishing,
- ◆ The forging

Choice of forging cavities in the longitudinal forgings shall be made according to the ideal forgings or by an analysis of prospective technological process. Procedure of forging an axisymmetric forging is shown in Figure 10.5. Forging is realized by one stroke, in one cavity. For each forging there is a separate initial semi-product available. Two or more small forgings can be forged together simultaneously, Fig 10.6

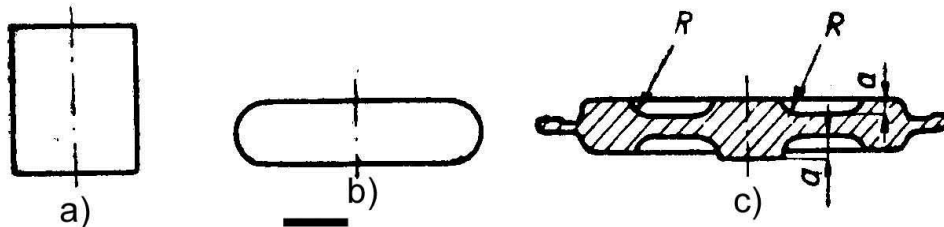

Fig. 10. 6. Examples of preparatory upsetting in shape cavities
a) initial semi-product, b) rough forging for upsetting, c) forging

Calculation of the deformation force for axisymmetric forging is carried out according to the relationship:

$$F = 80(1 - D_v) \left(1,1 + \frac{0,02}{D_v} \right)^2 S_v \sigma_p \quad (10.5.)$$

where F is the required force [MN]

D_v is the diameter of a forging in the parting plane [m],

S_v is the surface area of a horizontal projection of a forging [m²],

σ_p is a natural deformation resistance [MPa].

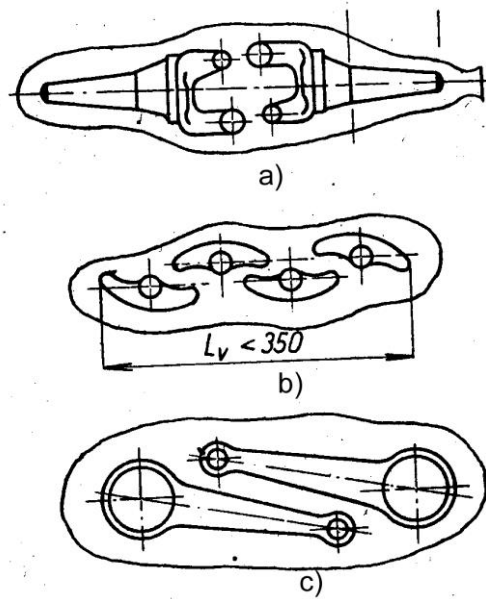

Fig. 10. 7. Common forging of smaller forgings

For other shapes of forgings:

$$F_1 = F \left(1 + 0,1 \sqrt{\frac{L_v}{B_{vs}}} \right) \quad (10.6)$$

where F is force for rotationally symmetric forgings where $D_v = 1.13 S_v^{1/2}$
 L_v is the length of a forging [m],
 B_{vs} is the mean width of a forging [m], $B_{vs} = S_v/L_v$.

Questions:

1. Enumerate basic principles of forging on crank presses.
2. How to calculate the deformation force for forging on crank presses.
3. Describe the diameter of the forging in the die parting plane?
4. What forces have crank forging presses?

Tasks to solve

1. Calculate deformation force at forging of a forging on a screw press: $D_v = 90$ mm, natural deformation resistance of steel at HKT = 30 MPa.
2. Define the shape a flash groove for the above mentioned forging.

11. DROP FORGING ON HORIZONTAL FORGING MACHINES

Chapter contents:

- Forging on horizontal forging machines
- Forging on hydraulic presses
- Preparation of rough forgings on forged rolls
- Trimming of flashes, punching and calibration of forgings
- Stress of dies and die steel



Time needed for studying: 120 minutes

Aim: After studying of this chapter

- You will be able to describe the technology of forging on HKS
- You will learn about the procedures of forging on hydraulic presses and about preparation of hydraulic presses, as well as about preparation of rough forgings on forging rolls
- You will be able to design and assemble tools for trimming and punching
- You will be able to choose suitable steels for dies for manufacture of dies



Explication

11.1 Drop forging on horizontal forging machines

Horizontal forging machine is a crank forging press which has, besides the main press ram with the punch, two jaws in which the initial semi-product is clamped first and then the free portion of it can be forged. Forging on horizontal forging machines has the following advantages:

- a) Forgings with a smaller drafts can be manufactures on them,
- b) Forgings of circular section can be forged even with through holes,
- c) The most of forgings are forged in closed dies,
- d) Flashes are removed on the forging machine

Horizontal forging machines with power of 40 MN operate at the speed of 15 to 30 strokes per min. The jaws have a horizontal or vertical parting plane. Priority is given to horizontal division, which is characterized by more favourable conditions for mechanization of in-process moving of a forged blank. The procedure of forging on a horizontal forging machine is shown in the Figure 11.1.

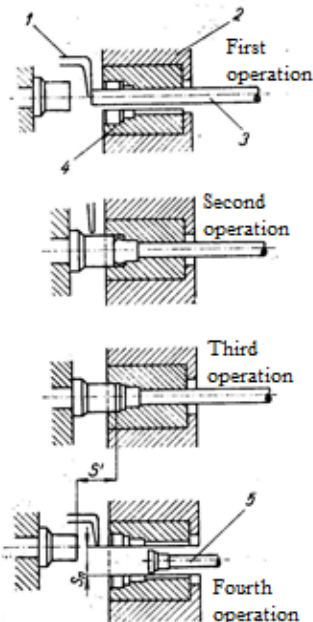

Fig. 11.1. Scheme of forging procedure on horizontal forging machine:
 1 – front stop, 2 – stationary /immovable jaw, 3 – semi-product, 4 – movable jaw, 5 – forging.
 S_n – opening of jaws, S' - stroke

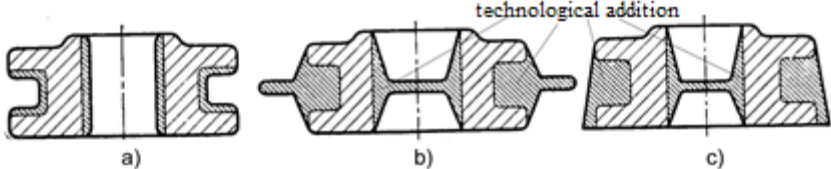

Fig. 11.2. Size of technological additives for closed die forgings forged on:
 a) on horizontal forging machine, b) in open die, c) in closed die

For forging there are used three-part dies with two parting planes being perpendicular to each other, which offers these advantages:

1. There are used circular rods or thick-walled pipes of diameters $d_o \leq 240$ mm, The forging has a minimum flash (better utility of metal).
2. There are manufactured full and hollow forgings of various lengths, complex in shape with minimal technological additives and a small lateral draft (Fig.11.2).
3. No waste is creating when punching

Disadvantages of horizontal forging machines:

1. Higher acquisition costs, reduced range of shapes.
2. Higher demands on the dimensional accuracy of the initial semi-product.
3. Risk of scale forging-in.
4. Reduced service life of dies.

There are used progressing forging in inserted dies. One part is clamped to the punch and the remaining two parts to the clamping jaws. Forging cavities are significantly different from cavities of other forming machines. There predominate upsetting and punching cavities, bending cavity, forming, trimming and parting cavities.

Axisymmetric forgings are forged from metal rods without any flash and with a higher dimensional accuracy (peeled and drawn bars). Axially asymmetric forgings are forged with longitudinal or transversal flashes which create in the flash groove (Fig. 11.3).

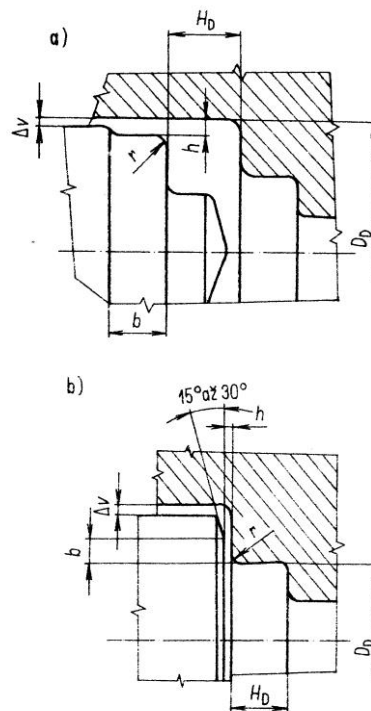

Fig. 11.3. Basic shapes of a flash groove in dies on horizontal forging machines
a) longitudinal b) transversal

The most common is the forming with a transversal (radial) flash which can be trimmed more easily, either directly on a horizontal forging machine, or on the trim crank press. Longitudinal flashes remain broadly on a forging because it is difficult to remove. The substantial parts of the assortment forged on the HKS are axisymmetric forgings, which can be divided into two groups:

1. Full forgings with a stem, which are forged from a rod whose diameter is equal to the stem diameter, the length of an unclamped portion of the rod (Fig. 11.4) must satisfy the condition:

$$l \leq (2,5 \text{ až } 3) d_o \quad (11.1)$$

If the condition cannot be met, there is performed pre-upsetting of a free part of the rod in a cylindrical cavity of the jaw (Fig. 11.4b) or cylindrical (Fig.11.4c) or conical cavity (Fig. 11.4d) of the punch. Between the diameter of the upset head and the stem the following relation is valid:

$$D_1 \leq 1,5d_o \quad (11.2)$$

The conical shape of the pre-upsetting cavity in the punch is suitable, because the desired reinforcement is achieved with the smallest number of operations.

2. Punched forgings are forged from a rod of a diameter corresponding to the diameter of the hole (Fig. 11.4). If this principle can not be met, then at the transition from the rod to a forging there the conical portion is forged so that its diameter at the point of connection to the forging would be equal to the diameter of the hole (Figure 11.4f, g). This procedure is almost waste-free punching.

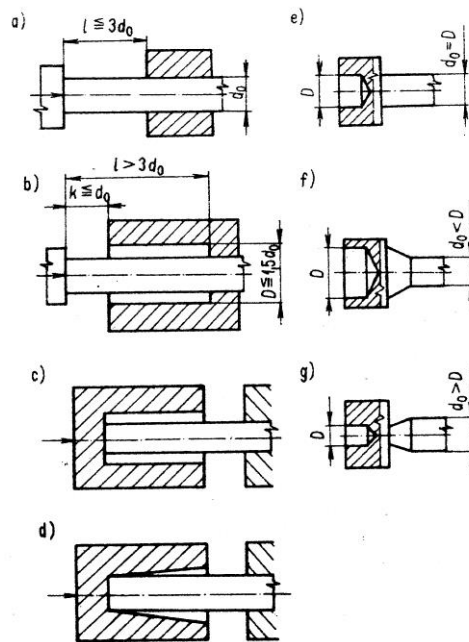

Fig. 11.4. Basic principles of forging on horizontal forging machines

The deformation force is calculated according to the relation:

$$F = \frac{5}{10^6} (1 - D_v) (1000 D_v + 10)^2 \sigma_p \quad (11.3)$$

where F is the force [MN],
 D_v is the diameter of a forging in the parting plane [m],
 σ_p is a natural deformation resistance [MPa].

11.2 Drop forging on hydraulic presses

On the hydraulic presses with the power of 200 MN (exceptionally up to 750 MN) there are made of closed die forgings of steel, but mainly of aluminium and magnesium alloys. Hydraulic presses with low working speed (0.15 to 0.20 ms⁻¹) are usually applied if it is not possible to manufacture the given forging on other forming machines, especially in cases of:

1. Forging of low-formable alloys required low deformation velocity.
2. Forging of large forgings namely for the aircraft industry.

3. Forging by extrusion
4. Forging of long hollow forgings.
5. Precise forging of shape-complicated forgings in split dies.

Hydraulic presses use for forging namely single-cavity dies, the finishing cavities. If there are used some preparatory cavities, these are then upsetting, bending and necking ones. The rolled bars and rods, as well as rough forgings are the initial semi-products there.

11.3 Preparation of rough forgings on forging rolls

Forging rolls are forming machines on which rough forgings are made for crank and screw presses on which preparatory operations as lengthening and parting cannot be realized. On forging rolls simple rough forgings without thin ribs and projections can be manufactured. Forming is the easier and better, the smoother are the changes of the cross section of the forging. In terms of follow forging it is the best to design the shape of the rough forging from forming rolls according to the cross-sectional shape of the ideal rough forging, or use a procedure by which we can determine the cross-sectional areas of the forging in critical decisive sections (Figure 6.11):

1. The rough forging shape shall be determined. The forging sectional areas C-C', D-D' and E-E' (Fig. 11.6a) shall be enlarged by the flash surface a then the single surfaces shall be transformed to circular or square profile.
2. According to the largest cross-section of the rough forging the profile of the initial material is determined and according to the volume (weight) of the forging the length of the forging shall be determined, too. The length of the initial material is determined by the largest cross-section (CC'), and subsequently the diameter of the initial material shall be determined too. By the partial volume of parts a, b, c, d, e, f, g, the total volume is determined, and with the aid of it is possible to determine the length of initial material:

$$L = \frac{V}{S} \quad (11.4)$$

where L is the length of initial material [mm]
V is the volume of initial material [mm³]
S is the largest cross section of the forging [mm²].

1. With the aid of the initial cross section (S_o) an the smallest cross section of the forging (S₁) the (surface) deformation ε shall be determined:

$$\varepsilon = \frac{S_o - S_1}{S_o} \cdot 100 \quad (11.5)$$

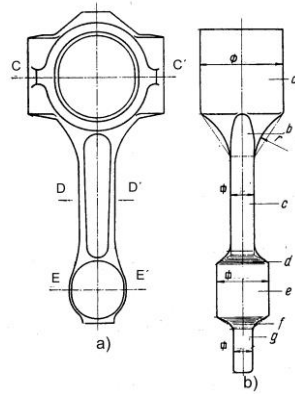

Fig., 11.6. Procedure of the design of the connecting rod rough forging:
 a) Forging shape, b) the rough forging made on forging rolls

Used methods of rough forming in gauges are shown in the Figure 11.7:

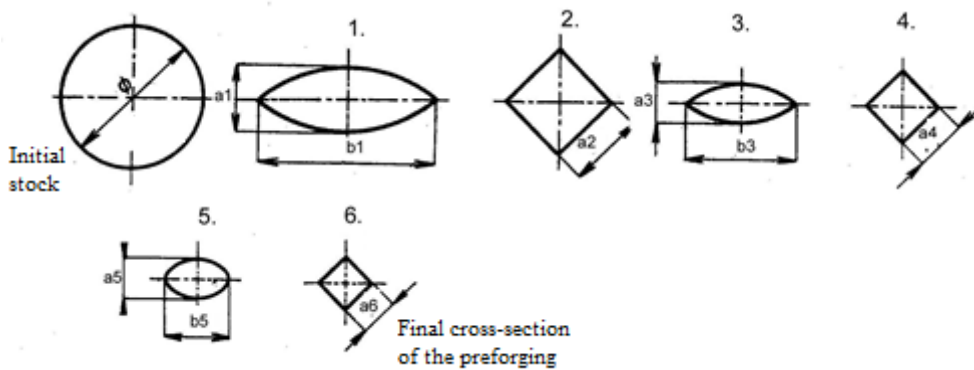

Fig.11.7. Change in the cross section of the rough forging when forming by six passes on forging rolls in the calibration range oval – square

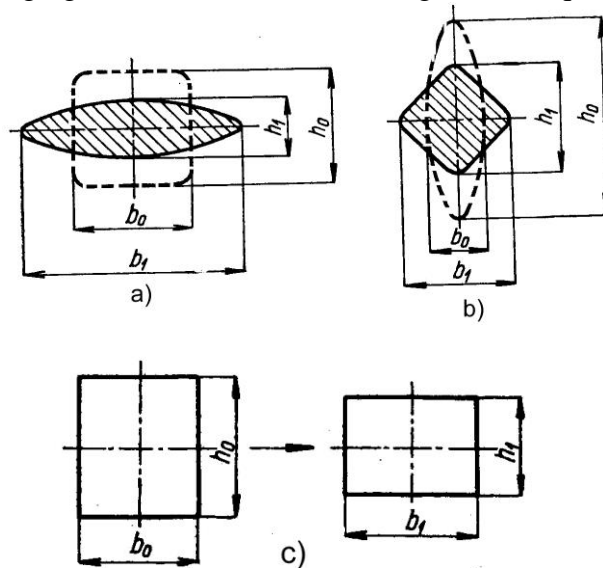

Fig. 11.8. Calibration for rolling the rough forgings
 a) square – oval, b) oval – square c) square - rectangle

A method of rolling is chosen with regard to the lengthening coefficient:

$$\lambda = S_0/S_p$$

(11.6)

where S_o is the cross section of an initial semi-product [mm²]
 S_p is a surface area of the largest cross section of the rough forging [mm²].

If $\lambda < 1.43$ it shall be rolled in one gauge through only one pass. If $\lambda > 1.45$ it is possible to roll using only one gauge, but more passes, according to the rough forging shape. After each pass the semi-product is tilted by 90°. Or optionally it is rolled in several gauges by only one pass. The combination of gauges for rolling is shown in the Fig.11.7.

The number of passes, as well as gauges can be determined as follows:

$$n = \frac{\ln S_o - \ln S_p}{\ln \lambda_s} \quad (11.7)$$

where λ_s is the mean coefficient of lengthening ; $\lambda_s = 1.2$ to 1.3 .

Progressive forming of a rough forging for a connecting rod is shown in the Fig. 11.9.

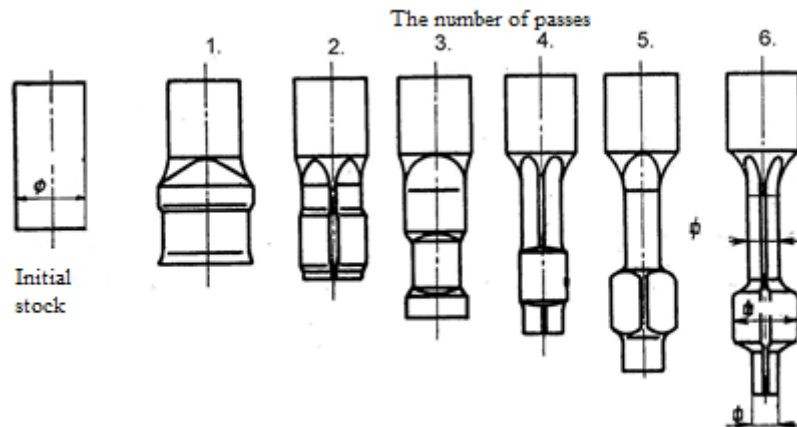

Fig. 11.9. Procedure of forming of a rough forging of a connecting rod on forging rolls

11.3 Trimming a punching of forgings

They are used for the finishing of forgings shapes. It is carried in hot or cold state on tools, on trimming and punching dies /tools clamped on trimming presses.

Trimming presses have a higher production rate than hammers, screw and hydraulic presses, and therefore it is preferable to trim forgings of these forming machines in the cold state. By this procedure some smaller forgings from carbon steels with a carbon content $w_c < 0.45\%$ and low-alloy steels ($w_c < 0.25\%$) are processed. Usually only one trimming press is used for two basic forming machines. Hot trimming is mainly used for high-performance vertical forging presses. The shear force for shearing and punching is calculated from the relation:

$$F = 2,7 R_m \cdot o \cdot s \quad (11.8)$$

where R_m is strength of material (MPa)
 o is circumference of a flash (mm)
 s is the thickness of a flash (mm)

Constructional workmanship of the trimming tool and a punching die is presented in the Figures 11.10 and 11.11. Besides the above mentioned tools there are used so called

combined – comprehensive tool on which trimming and punching procedures are realized simultaneously, Fig. 11.12.

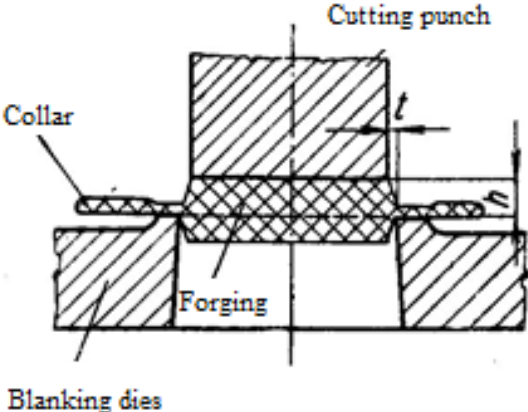

Fig. 11.10. Flash trimming

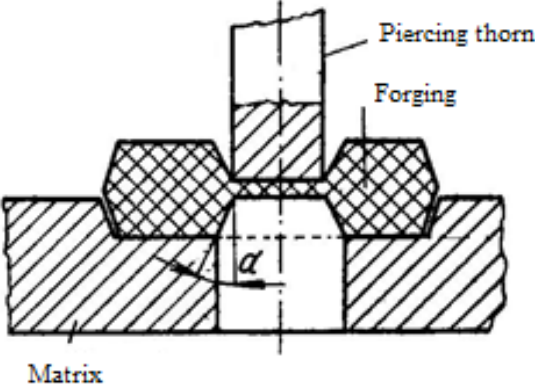

Fig. 11.11. Scheme of punching

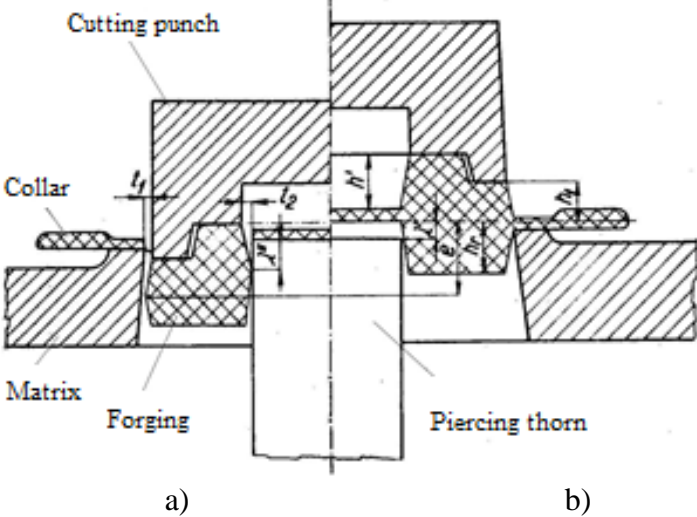

Fig. 11.12. Tool for trimming and punching:
 a) the final stage of trimming and punching, b) initial stage

11.4 Straightening and calibrating

Forgings with thin ribs can be distorted when trimming a flash. Smaller forgings are straightened when cold, large forgings when hot. Straightening is performed directly in the finishing cavity of a die, or in a straightening die clamped set on the trimming press.

By calibration, which is done on crank and toggle presses forging dimensions can be refined, and the surface quality can be improved. By areal calibrating carried out in the cold state the dimensions between parallel surfaces of the forging can be more specified (Fig. 11.13). By the volume calibration it is reached better accuracy of all dimensions of the forging. The calibration is carried out either in the hot state or in the cold state, the excess metal is forced into a small flash which is ground off during the final operation.

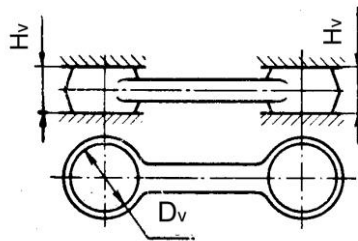

Fig. 11.13. Areal calibration of a forging

11.5 Stress loading of dies

When forging, dies are subjected to mechanical and thermal stresses. This stress cycle is repeated at various forging operations. By increasing the speed of forging operations which are used in forging of high-alloy materials not only the total stress further increases, but also the quality requirements on dies.

11.5.1 Mechanical stress

Various methods of die forging, different segmentation and sizes of forgings can cause diverse types of mechanical stresses. The forces acting during forging cause compression and expansion of the die, and under dynamic loads the impact –strokes act on the die too.

In addition, there is a die abrasion, particularly in transitions around flashes. Therefore, high resistance to pressure and also sufficient strength is requested from dies. High resistance to elevated pressures and abrasion resistance are closely related to the strength (hardness) of the die. The higher is the strength, the better the die can withstand these effects. High strength however reduces toughness and under certain circumstances it can cause the die cracking.

11.5.2 Thermal stress

High temperature when forging reduces the strength of dies on functional parts and increases the plastic properties of the steel. This leads to deformation of the die cavity, to the increase of abrasive wear, and loss of dimensions is much faster.

Another factor of thermal stress there are variations in temperature on the functional part of the die. This is caused by heating of the die cavity, followed by cooling during different forging operations. Periodic variations in temperature induce changes in volume that result in the stress in the surface layers of the die cavity and even lead to the formation of a network of cracks. Cracks arising due to thermal fatigue promote faster die wear or may be a source of more larger cracks and fatigue failures. The formed material is pushed into these cracks, which supports their extortion and enlarging.

The proposed strength of dies depends on:

- a) types of forgings (size, complexness, chemical composition of the forged material, its initial shape and its in-process shape),
- b) sizes of dies,
- c) quality of the tool steel for a die,
- d) methods of forging and power of forging machine,
- e) operating conditions (forging-finishing temperature, operating temperature of a die, die handling, and so on).

Selecting the strength of dies is based on operating experience. Strength at different types of dies is ranging from 1000-1800 MPA. Great strength increases resistance to abrasion and plastic deformation, but also reduces toughness and resistance to cracking from thermal fatigue. Large strength, especially of hammer dies causes cracking or adds to it at least. Creation of small cracks supports not only fatigue fracture but also the more rapid wear of the die cavity. Low strength increases substantially toughness, but results in rapid loss of shape and dimensions of the cavity die due to increased wear and plastic deformation. There are general guidelines for selection of strength, determined by operational experience. They show, however, only a certain range of dies strength. Considering one, two or maximum three aspects, such as:

- a) the weight of the die,
- b) the size and nature of the die cavity,
- e) the type and power of the forging machine
- d) according to the weight of the die and the die cavity depth, material used for a die making and the type of the forging machine

Scope of used strengths according to the given aspects is not given explicitly. Under the influence of individual factors, we can establish the following general principles:

- a) the greater impact the forging machine can reach, the lower is the selected strength. Strengths of the forging stresses will be on average higher than those of hammers,
- b) higher power of forging machine (hammer) conditions less strength of dies,
- c) the power out of a forging machine shall comply to the die size; the larger, the deeper and more complicated is the die cavity, the lower is the strength of steels destined for dies. And the smaller is the die and the simpler and shallower is the shape of the cavity, the higher strength is used.

11.5.3 Steels for dies

Due to high mechanical and thermal stresses of forging tools the following requirements are imposed to die steels:

1. High strength and toughness over the whole range of forging temperatures,
2. Good hardenability and the tempering temperature highest as possible,
3. low thermal expansion and the thermal conductivity highest as possible,
4. High abrasion resistance,
5. Resistance to thermal fatigue cracking,
- 6 Good machinability and good price of steel.

All these properties can not be obtained by any combination of alloying elements and, therefore, producers focus on ensuring critical properties. According to the content of the main alloying elements, tool steel for working in hot conditions is divided as follows:

- a) tungsten,
- b) chromium-molybdenum,
- c) nickel,
- d) chrome,
- e) carbon.

Chemical compositions of selected brands of die steels are given in Table. 1, their recommended use is in the Table 2.

Table 1. Chemical composition of die steels

Mark steel	Chemical composition, wt %							
	C	Mn	Si	Cr	Mo	W	V	Ni
19 464	0,40 0,50	0,50 1,00	0,70 1,20	1,70 2,20	-	-	0,20 0,40	-
19 512	0,35 0,45	0,50 1,00	max. 0,50	2,20 2,80	0,40 0,80	-	0,35 0,60	-
19 552	0,30 0,40	0,20 0,50	0,80 1,20	4,50 5,50	1,10 1,70	-	0,35 0,60	
19 642	0,30 0,40	0,40 0,70	max. 0,45	0,70 1,20	-	0,20 0,60	-	4;20 5,30
19 650	0,50 0,60	0,40 0,90	0,20 0,60	0,90 1,30	-	0,30 0,80	0,05 0,25	1,40 1,90
19662	0,50 0,60	0,40 0,90	0,20 0,60	0,50 0,90	0,15 0,30	-	0,07 0,20	1,40 1,90
19 663	0,50 0,60	0,40 0,90	0,20 0,60	0,90 1,30	0,25 0,50	-	0,10 0,30	1,40 1,90
19720	0,25 0,35	0,20 0,50	0,15 0,50	2,00 2,80	-	3,80 4,80	0,45 0,65	-
19721	0,25 0,35	0,20 0,50	0,15 0,50	2,00 2,70	-	8,50 10,00	0,10 0,30	-
19 740	0,25 0,35	0,20 0,50	0,80 1,40	1,00 1,50	-	3,20 4,00	0,10 0,30	-
								-

Table 2. Use of die steels

Mark steel	Typical use of tool steels			
	sizes dies	stress dies	kind of forging machine	forging material
19 464	small and medium-sized dies	slightly thermally stressed tools	hammers, screw presses, forging presses	unalloyed and low alloyed steels, light metal alloys and lead
19 512	small die thickness to 200 mm	moderate heat stress instruments	hammers, screw presses, forging Presses	unalloyed, low-alloy steel, light alloys
19 552	small die thickness to 200 mm	high thermal stress tough tools	hammers, screw presses, forging Presses	unalloyed, low-alloy steel, light alloys
19 642	small, medium and large dies	moderate heat stress instruments with great tenacity	particularly hammers, screw presses and forging presses	unalloyed, low-alloy steel, light alloys
19 650	small, medium and large dies	moderate heat stress tools with good toughness	hammers, screw presses	unalloyed, low-alloy steel, light alloys
19 662	medium and large dies	moderate heat stress instruments with great tenacity	primarily hammers	unalloyed, low-alloy steel, light alloys
19 663	small, medium and large dies	moderate heat stress instruments with great tenacity	hammers; screw presses and forging presses	unalloyed, low-alloy steel, light alloys
19 720	small die thickness to 200 mm	high thermal stress enough tough tools	all types of presses and hammers	all types of steel, copper alloys and light metals
19 721	small die thickness to 200 mm	high thermal stress enough tough tools	all types of presses	all types of steel, copper alloys and light metals
19 740	small die thickness to 200 mm	high thermal stress enough tough tools	all types of presses	unalloyed and low alloyed steels; light alloys
				unalloyed and low alloyed steels; light alloys

Questions:

1. How can you characterize forging on HKS?
2. For what types of forgings the forging on hydraulic presses is used?
3. With the aid if which calibration can you made a rough forging on forging rolls?
4. How do the operations of the product trimming and punching proceed?
5. What factors can cause the dies wear?

Tasks to solve:

1. Calculate the deformation force for forging on HKS. The rod is produced of the steel X12Cr13, and it has a diameter 45 mm, the forging diameter in the parting plane is $D_v = 70$ mm.
 2. Calculate the number of passes when manufacturing a forging on forging rolls. Diameter of an initial semi-product is $D_o = 52$ mm and max. diameter of a forging is $D_p = 75$ mm.
 3. Calculate the force needed for the flash trimming on the forging being shown in the following Figure. The forging is of the steel X3CrTi17.
-

12. HEAT TREATMENT AND REQUIREMENT TO PROPERTIES OF FORGINGS

Chapter contents:

- Cooling down the forgings from finishing temperatures
- Heat treatment of open die forgings
- The performance requirements for demanding steel forgings



Time needed for studying: 120 minutes

Aim: After studying this chapter

- You will be able to describe procedures of heat treatment of forgings
- You will be able to define requirement to properties of forgings
- You will acquaint with new types of steels for demanding forgings



Explication

12.1 Large forgings cooling

Cooling of forgings affects the final resulting properties of a forging. The forged semi-product becomes cool immediately after its removal out of a furnace. After forging the most of forgings is cooled down in an open air. For time needed for cooling down of forging the following relation is valid, however only approximately:

$$\tau = 0,0066 \Delta T d \quad (12.1)$$

where τ it is the time for cooling-down (s)

ΔT is temperature difference over the cross section of the forging e (K).

d is the diameter (m)

With forgings of a larger cross-section of steel with reduced thermal conductivity there shall be used a slower cooling-down process to achieve the required mechanical properties, prevent the creation of surface and internal cracks, release residual stresses and to prevent surface hardening. It is most preferred to combine cooling with subsequent heat treatment.

In the initial stage of cooling-down ($t > 550^\circ \text{C}$) the tensile thermal stresses are formed on the surface of the forging and pressure thermal stresses in the core of the forging occur. At the end of cooling ($t < 550^\circ \text{C}$) the sense of thermal stresses changes. In the core of the forging can happen even a cohesive failure in extreme cases.

The suggested idea of origin and the change of a sense of thermal expansion is valid only for so called mild steels. When cooling-down steels of a higher strength the change of sense of thermal expansion is little probable (the limited relaxation ability of steel), so even microscopic surface cracks can extend enough due to tensile stress that the forging can be completely destroyed. When cooling, besides thermal stress it is necessary to take into account origin of recrystallization and residual stresses. In order to reduce internal stress, the cooling rate shall be reduced by cooling the forgings in piles, in metal boxes, in insulation fillings, in cooling-down pits or kilns.

Forgings of non-alloy (carbon) steels are cooled in the open air, if their diameter d and the weight proportion of carbon satisfy the following conditions:

$d < 200 \text{ mm}$	$w_C \leq 0.45$
$d = 200 \text{ to } 600 \text{ mm}$	$w_C \leq 0.40$
$d > 600 \text{ mm}$	$w_C \leq 0.30$

For forgings of alloy steel the following cooling procedure is recommended:

1. Thermal arrest on temperature 650 to 700 °C within $\tau = d/25$ (h), where d is the diameter of forging(mm),
2. Cooling in the furnace with speed of 10 to 12 K h⁻¹ at 200 °C,
3. Air cooling.

The special case of internal defects that arise during cooling of forgings are flakes. The main cause of origin of flakes is the simultaneous acting of two factors: a critical concentration of hydrogen in steel ($H \geq 2 \text{ cm}^3/100 \text{ g}$ of steel) and internal stresses in forgings. Their origin is explained by the slowed-down fracture mechanism that is developed after a certain incubation period due to the effect of lower voltage than expected, considering the tensile strength. The flakes origin shall be prevented using the antflake annealing that directly follows the finishing temperature (Fig. 12.1). The purpose of annealing is to reduce the concentration of hydrogen in the steel below the critical level.

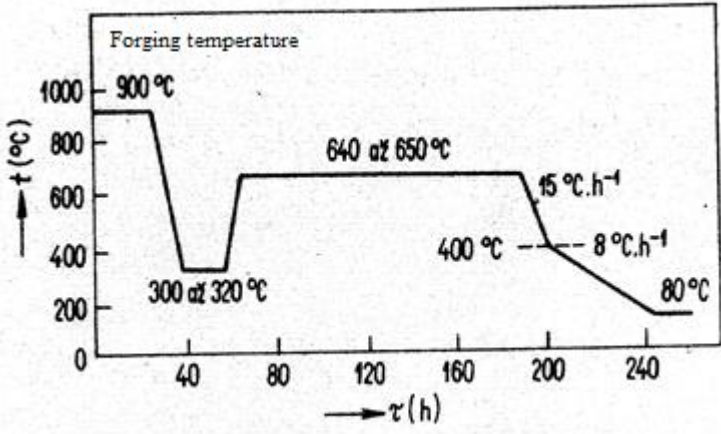

Fig. 11.1. Antiflake annealing of forging with $d_{max} = 1\ 030 \text{ mm}$ of steel 34ChN3M

12.2 Heat treatment of forgings

Although the forging has a positive influence on the structure and properties of forgings, it is necessary to use heat treatment by which the overall quality of forgings can be further improved, taking into account their further processing and use. The basic methods of heat treatment of forgings include:

12.2.1 Annealing to reduce stress

It is a very efficient method of releasing internal stresses which have accumulated in the forging within operation of straightening, welding, burning and cooling and which could lead to distortion, destroying or fracture of the component.

Typically there is used the following procedures:

1. Slow heating to a temperature of 450 to 650 ° C (preferably using heat of the forging cooled down from the finishing temperature).
2. Thermal arrest at annealing temperature for the time $\tau = d/25$ (h), $\square \square = d/25$ (h) where d is the diameter of the forging (mm).
3. Cooling in a closed furnace with speed of 10 to 12 K. h⁻¹ at the temperature of 200 ° C.
4. Cooling in an open furnace, or in the open air or in a sand filling.

12.2.2 Soft annealing

The purpose is to spheroidize carbides in the ferritic matrix and hereby improving the machinability of steels with increased concentrations of carbon ($w_C > 0.5$ %) and alloy steels. The basis procedure is the long-term annealing just below the Ac1 temperature A_1 , (Fig. 12.2a) but with some eutectoid and hypereutectoid steels it may last over 40 hours. More economical procedures are offered in the Fig. 12.2 b, c.

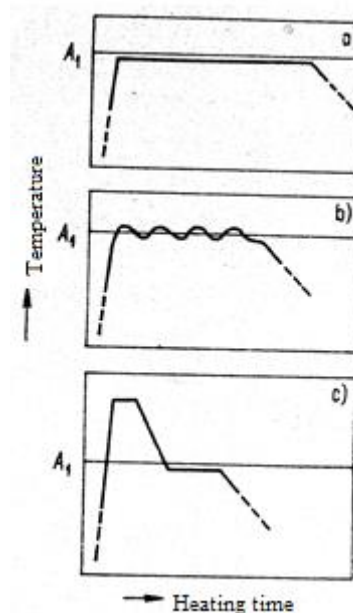

Fig. 12.2. Methods of soft annealing with steels for roller bearings:
a) annealing below temperature A_1 , b) annealing with cycling about temperature A_1 ,
c) annealing after austenitizing

12.2.3 Normalizing annealing

With forgings of hypo-eutectoid steels it is possible to obtain a uniform fine grain structure using the above mentioned annealing process. The base is heating 30-50 ° C above the Ac3 temperature, the thermal arrest (austenitization) and subsequent cooling. The heating system can be established according to the diagram in Figure 12.3 based on the carbon equivalent C_e

$$C_e = w_C + 0,2w_{Mn} + 0,25w_{Cr} + 0,33w_{Mo} + 0,1w_{Ni} + 0,2w_V + 0,2w_{Si} + 0,1w_W + 0,2w_{Ti} + 0,1w_{Al} - 0,1 \quad (12.2)$$

Where w_i je the proportion by weight of the i-th element in the steel (%). Equation (12.2) applies to the steel of the following chemical composition:

$w_C \geq 0,9\%$, $w_{Mn} \leq 1,1\%$, $w_{Cr} \leq 1,8\%$, $w_V \leq 0,25\%$, $w_W \leq 2,0\%$,
 $w_{Si} \leq 1,8\%$, $w_{Mo} \leq 0,5\%$, $w_{Ni} \leq 5\%$, $w_{Ti} \leq 0,5\%$, $w_{Al} \leq 2\%$.

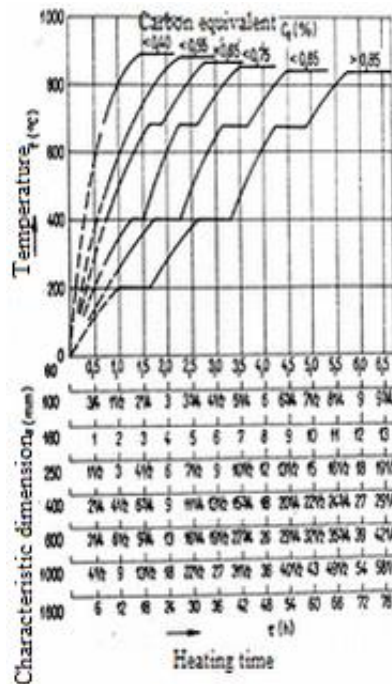

Fig.12.3. Normalizing modes (characteristic dimension s is determined from the Table 1).

Table 1, The characteristic dimension of forging for the determination of the heating time within normalizing annealing of forgings

shape forging		The characteristic dimension, s
forgings longitudinal	circular section	Forging diameter, d
	square section	Side of the square, a
	rectangular section	The height of the rectangle, h
hollow body		Wall thickness, t
disks full		Blade height, h
Perforated discs and rings		Height forging h or wall thickness t

Charging temperature is calculated from the relation (5.12), the thermal arrest at the austenitizing temperature $\tau = t/60$ (h), where t is the thickness of the forging (mm). With

increasing concentrations of alloying elements, the thermal arrest is extended to complete dissolution of carbides.

Cooling-down from the austenitizing temperature must be fast to achieve the finest dispersity of the resulting structure. With smaller cross-sections cooling in open air is sufficient, with larger cross-sections cooling shall be accelerated by flowing air, or by immersion in an oil bath.

12.3 Requirements on properties of steel for demanding forgings

The adverse effect of alloyed and additive elements on the mechanical properties of steel is known. Phosphorus, antimony, arsenic interacting with silicon and manganese cause temper brittleness and lead to a reduction in fracture toughness K_{IC} and a shift in transition temperature to higher temperatures. Sulfides and non-metallic inclusions based on aluminum and silicon can facilitate the formation of cavities at the grain boundaries and inside of grains, thereby contributing to the formation of creep fractures at elevated temperatures to give the plastic fracture in the area above the upper transition temperature. Advances in metallurgy in recent years caused the unwanted elements can be reduced to below 20 ppm, thus creating the opportunity to produce clean steel. Limitations of sulphur below 10 ppm no longer requires additive manganese steel and manganese can be reduced to 0.01 to 0.02%. Such steel is known as a 'super-clean steel'.

Production of clean and super-clean steels was allowed thanks to the secondary metallurgy using ladle furnaces in conjunction with a vacuum processing in the ladle and when casting. These procedures allowed the manufacture of steel of such purity that until then was only possible in the laboratories. The heats are conducted so that the *Mn*, *Si*, and *P* were removed already in the oxidation stage of heats, as these elements oxidize more easily than iron and enter into oxidation slag.

It is generally possible in an electric arc furnace. Tin, arsenic and antimony are reduced in the first round by choice of pure scrap that is melted by alkaline oxidation process. From the melt in an electric arc furnace oxidizing slag is removed and melt is poured into a ladle furnace with reducing slag to remove the sulphur. With vacuum processing of desulphurized steel in the ladle furnace and under melt bubbling by argon deoxidation by the VCD process is realized. This ensures a smaller content of oxide particles in the melt than with deoxidation by means of silicon additives. In this stage also alloying additives are added. The operation is ended by casting into ingots in the caisson. By this relatively high degassing under effective support of bubbling by argon nitrogen, hydrogen and also oxygen have been removed. The result is a super-clean steel where harmful elements were reduced to a minimum, as well as contents of oxides and sulphides. These steels are currently extensively used for some types of demanding open die forgings...

12.3.1 Steels for turbine rotors

Clean and super-clean steel have improved fracture toughness and high resistance to tempering brittleness (Table 2). These properties are required in the manufacture of the rotor and discs of turbines. It is due well-known rotors and discs crashing under high thermal stress generated during start-up and shutdown, on the basis of high-speed tests as well as during normal operation at low temperatures..

The very good example of the development of steel cleanliness in a longer time interval is

steel 1Cr1Mo0, 25V, which was produced as early as in the 50s of last century. Initially tolerated contents of phosphorus and arsenic were 250 ppm, in the case of sulphur 200 ppm, in the case of tin 150 ppm, and in the case of antimony - 50 ppm. In the 90s, that steel was produced with a tolerance of P, Sn and As at 30 ppm, S = 20 ppm, and Sb = 15 ppm. Significant improvements also occurred in NT steels based on Ni. As an example, the chemical composition of 3.5 NiCrMoV steel in the existing ordinary state, in pure state and in a superclean state can be given (Table 2). For this steel was calculated J factor [$J = (Mn+Si)(P+Sn).10^4$] in the first case 48, in the second case 10 and the third case only 1.6.

The results of the introduction of these steels in the industry are very interesting. During the period of years 1990 to 1993 there were produced 200,000 tons of rotor steel, of which about 5% were the super-clean steel. European producers had objections against maximum content of tin and arsenic, while Japanese manufacturers had objections only against arsenic. No substantial problems were with Antimony low content. Two manufacturers required increase of the maximum Mn content to 0.10 or even to 0.12%. European manufacturers also required reduction the border contents of As, Sb and Sn. This trend is fully in conformity with the scrap situation in the European territory.

In the near future it will be necessary to check and define thoroughly the limit contents of elements P, S, As, Sb and Sn in steels which in the synergy with other alloying elements have not ensured any further improvements of the steel properties in the operating cycles. Additional requirements concern the maximum permissible content of Mn in super-clean steels. Similarly, there is an increased interest in the production of super-clean CrMoV steel and 12% Cr steels..

Evidently it is essential to give the need of clean and super-clean steels in accordance with the design and requirements for operation of turbines. It is also necessary to harmonize requirements of manufacturers and customers, since the requirements to the level of transit temperatures, impact toughness and fracture toughness K_{IC} levels are often very different and shall be dealt with on a case by case basis.

Table 2. Chemical composition of steel 3,5NiCrMoV

Steel	C	Mn	Si	P	S	Ni	Cr	Mo	V	As
Common	0,26	0,30	0,042	0,008	0,012	3,47	1,77	0,39	0,12	0,006
Superclean (max.)	0,30	0,05	0,05	0,005	0,002	3,75	2,00	0,50	0,15	0,005
Required (max.)	0,25	0,02	0,02	0,002	0,001	3,50	1,65	0,45	0,10	0,002

The requirements for cleaner steel are also reported from other industries such as the chemical industry, manufacturers of pressure vessels and other pressure components, and even builders of offshore structures.

12.3.2 Steels for hydroprocessing vessels and containers

Even in other industries there are beginning to emerge new demands on cleanliness of steel that is associated with the level of transition temperature, susceptibility to corrosion cracking in corrosive environments, the susceptibility to temper brittleness and hydrogen embrittlement of steel.

As an example there is the steel for hydroprocessing containers for oil refineries. The current concept is highly pure steel of 2.25 Cr-1Mo, but in the world (and especially in Japan) in recent years there have appeared steels based on Cr-Mo-V, as original steels 2.25 Cr-1Mo with the addition of vanadium or as new types of steel 3CR-1Mo-V. In the original steel there is used either criterion either of J-factor, factor X by Bruscat. J-factor values are at maximum 50 and factor X is required at a level below 12th. The factor X was originally considered for welded joints and it is listed in the following equation:

$$\bar{X} = \frac{(10P + 5Sb + 4Sn + As)}{100} \quad (12.3)$$

where the contents of elements are reported in ppm.

When producing steel for hydroprocessing pressure vessels there is assumed the stable metallurgy, so that the only one variable element becomes tin, respectively, phosphorous and tin. For steel, 2.25 Cr-1Mo in metallurgy of the type VCD the values of the factor J i at 10-20, but with a significant reduction in Mn and Si can be achieved. Against this, however, there are the increased strength requirements, which do not allow decrease of substitutional elements Mn and Si to the level that is due to the super-clean steel for turbines. Generally it is stated that if P + S reaches the 0.010%, one can not expect a more prominent shift in the transition temperature. This can be confirmed as the results of previous years (1985 to 1986) and the present. From the previous results, when by the Cr-1Mo-duplex technology with preparation of steel in the SM-steel furnaces the steel 2,25Cr-1Mo was developed follows that for most of the heats with the factor J to 80 it is possible to achieve a shift in transition temperature of toughness to 20 °C. This shift is positive when the temperature reaches transit temperature as supplied at -100 to -80° C.

12.3.3 Steels for offshore structures – anchor systems

In these steels there are required high strength levels associated with low transition temperatures and high toughness at the upper level of transition temperature. From the point of view of the world there are used for anchoring systems of platforms of the kind TLP (tension leg platforms) the steels of the type Cr-Mn, 3.5 NiCrMoV, 3NiCrMo, 2.8 NiMo and 2NiCrMoCuNb. Carbon equivalent for these steels ranges from 1 to 0.7%, for the steel on the basis of NiMo it is even to 0.5 Recently, from the steel A707, HY-80 and a steel according to NORSOK's requests there was produced the heat of 50 t, which has passed both in terms of a low-level carbon factor, and in terms of high standards of strength and toughness properties of steel. At about 75% of the above mentioned steels, the requirement for harmful elements has

been defined by the level of 50 ppm. In the Table 3 there are given basic properties of developed steel together with values of the notched impact toughness at - 40 and - 60°C. s revealed from further evaluation, steel is also completely resistant to cathodic hydrogenation that occurs during prolonged exposure of forgings to sea water.

Table 3. Mechanical properties of steel for anchoring system of platforms

Forging/w eight	Processing	R _{p0,2} [MPa]	R _m [MPa]	A ₅ [%]	Z [%]	KCV [Jcm ⁻²]
Forging	Laboratory	790	887	21,5	70,6	177
	HT Industry HT	769	875	21,5	66,8	152
45t	Basic HT	494	815	22,7	67,3	158,147,161
		584	816	22,4	68,2	155,161,147
45t	Repetitive Stress relieving HT	632	808	24,4	65,7	131,150,142
		646	795	23,6	65,3	139,134,144
		640	814	24,0	67,3	136,142,147
		631	809	23,6	66,5	150,136,136
26t	Basic T, sea waterZ	708	818	17,1	66,5	150,155,147
		656	799	20,0	68,1	161,163,150
26 t	Repetitive Stress relieving HT	675	790	22,3	67,6	136,136,144
		680	795	21,6	59,6	131,139,139
		670	792	21,4	65,4	136,129,134
		678	793	22,9	68,4	150,169,158

12.3.4 Supermartensitic steels

As for the supermartensitic steels considered the builders of offshore platforms appreciate their resistance to sea water, aggressive mixtures of oil, natural gas with H₂S and seawater, CO₂. The high resistance of the steel relative to said mixture and seawater is achieved primarily with high purity of steel and secondly by suitable choice of microstructure (martensite and reverse austenite). Regarding the purity of the steel, the primary requirements are on reduction significantly the carbon content below 0.015%, and then reduction of reduce sulphur (max. 0,002%) and phosphorus (max. 0,020%). Reducing the carbon content will reduce the precipitation of M₂₃C₆ type carbides at grain boundaries, which leads to high resistance to stress corrosion cracking and hydrogen brittleness. Limitations of phosphorus, are not so significant, but even at this level shall be taken into account that the susceptibility to temper brittleness is significantly reduced. Low sulphur content increases toughness of high-tempered martensite and contributes to the overall level of toughness. To illustrate this case there is the Table 4 containing the results of heats of the 16/5Mo steel having a chemical composition approximating to the desired solution.

12.4 Summary

When limiting the content of harmful elements and associated elements for turbine rotors there was achieved increased fracture toughness, reduced transition temperature impact toughness and complete resistance to generation of temper brittleness while maintaining or increasing the creep strength and plasticity of steel.

At the same time, this means that the improved properties of the steel are reflected in the

increased lifetime, the elimination of unexpected outages, extending the interval between scheduled inspections, faster operation starting-up and the possibility of cycling, elimination of preheating prior to the operation voltage and increase the efficiency of the NT rotors due to increased working temperatures.

There were also listed other branches of industry that are interested in the efficiency of reduction of harmful elements. Namely, there are pressure vessels and equipment operating at elevated temperatures, steel offshore structures and supermartensitic steels

Questions:

1. Can you characterize the requirements on the chemical composition of super-clean steel?
 2. What procedures are used for cooling-down of large forgings from the after-finish temperatures?
 3. By what procedure can you determine J and X factors of steel?
 4. What is the maximum content level of undesirable elements in super-martensitic steels?
-

Tasks to solve:

1. Calculate the values of J and X factors for steels: 3,5NiCrMoV, 3NiCrMo, 2,8NiMo and 2NiCrMoCuNb.

13. DEFECTS OF FORGINGS

Chapter contents:

- Defects of ingots
- Defects of forgings and their indications
- Defects of open die semi-products and rolled semi-products
- Defects arising from heating, forging and cooling of forgings



Time needed for studying: 120 minutes

Aim: After studying this chapter

- You will be able to describe surface and internal defects of initial semi-products and forgings
- You will be able to calculate deformation forces and utilization of input materials
- You will learn the basic methods of removing defects in forges



Explication

Imperfections (defects) that occur during open die forging represent the most unpleasant technical and economic problem. Forgings are in fact usually more expensive than castings. Since "costs more, more is expected of them." Therefore, it is necessary to devote defects systematically and to seek ways to prevent them. Distinction is made between cracks and fissures, as shown in Figure 13.1.

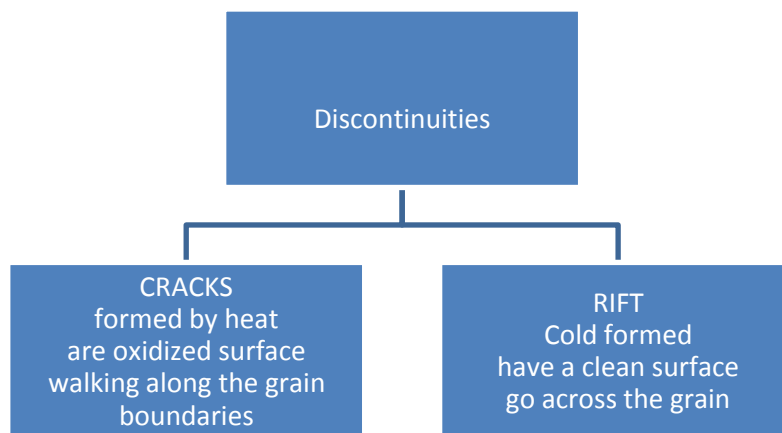

FIG. 13.1 Main differences between the cracks and fissures

Imperfections within the forgings are usually revealed during ultrasonic examination. Ultrasonic indications, however, does not necessarily mean that in the volume of forgings are imperfections, as shown in Figure 13.2. They may also be coarse inclusions or areas with a different structure. For example, coarse ferritic strips or Widmanstätten structure may occur as an indication.

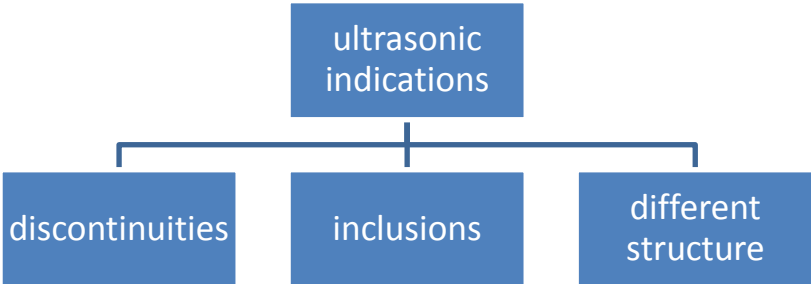

FIG. 13.2 Possible causes of ultrasonic indications

Great attention has been paid to the overview of defects occurring in the open die forgings. Individual works, however, are quite different, depending in which area the author gathered experience.

In further analysis and with dividing imperfections we will start from the moment when the defects are formed as schematically shown in Figure 13.

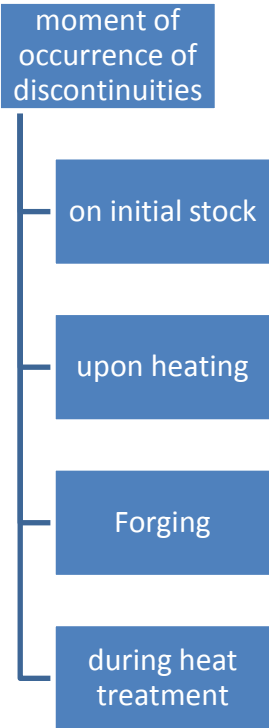

Fig.13.3 Scheme of dividing imperfection according their arising moment

As input semi-products for manufacture of open die forging there are forging ingots, semi-finished casting products and to a lesser extent rolled billets.

13.1 Imperfections on billets

In the bars there is a large range of defects. We will discuss only the most common. An overview is shown in Figure 13.4.

A wide range of defects occur in ingots. We will only deal with the most common ones. Their overview is shown in fig. 13.4.

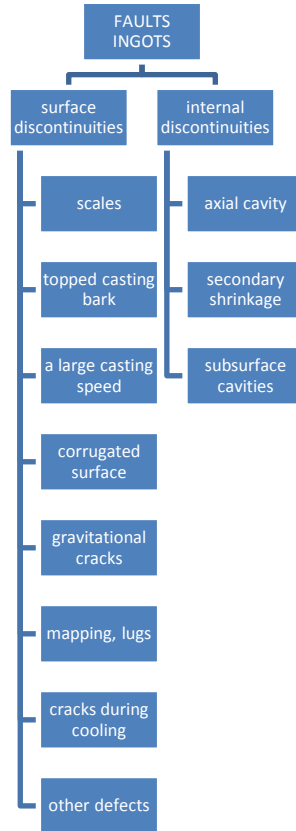

Fig. 13.4 Overview of the main ingot defects

13.2 Surface defects of ingots

Scales form through scattering during casting from above. The metal spurted onto the wall of the ingot mold solidifies sooner than it is covered by the rising surface. Scales may occur anywhere on the surface of the object and have irregular shape. They tend to be shallow and can be easily burned out during forging. Casting from below is prevalent today, which generally leads to surface quality improvement.

Rolls and wavy surface usually occur on a large part or throughout the entire surface of the ingot body. In explaining their creation we have to start at the situation during the ingot casting shown on fig. 13.5. Liquid steel does not wet the surface of the ingot mold, therefore the surface has a convex shape. There is a layer of slag floating on the surface of the molten casting powder. The metal solidifies very quickly near the walls. Solidification then continues in the direction of the main crystallographic axes, which means that the width of the wall is irregular from a certain point; however, the solidified layer can be characterized by angle α . At the top, the solidified layer is curved towards the inside. As the surface rises, this curved part must be straightened out. If it is too strong, it will not straighten and is overcast by liquid metal. This can result in a formation of an unseemly wavy surface in an ingot cast in a

smooth ingot mold. The reason is a low casting temperature and low casting rate. Some steels, especially the more alloyed ones, have high tendency to these defects. This defect often requires the entire ingot surface to be cleaned.

The overcast casting scab is a thick discontinuity, usually quite deep, filled with slag, perpendicular to the ingot axis. In explaining this defect formation, we also start at fig.13.5. A layer of slag which floats on the surface is caught at the edge of the ingot mold and is overcast by metal. This defect usually leads to dismissal of the ingot.

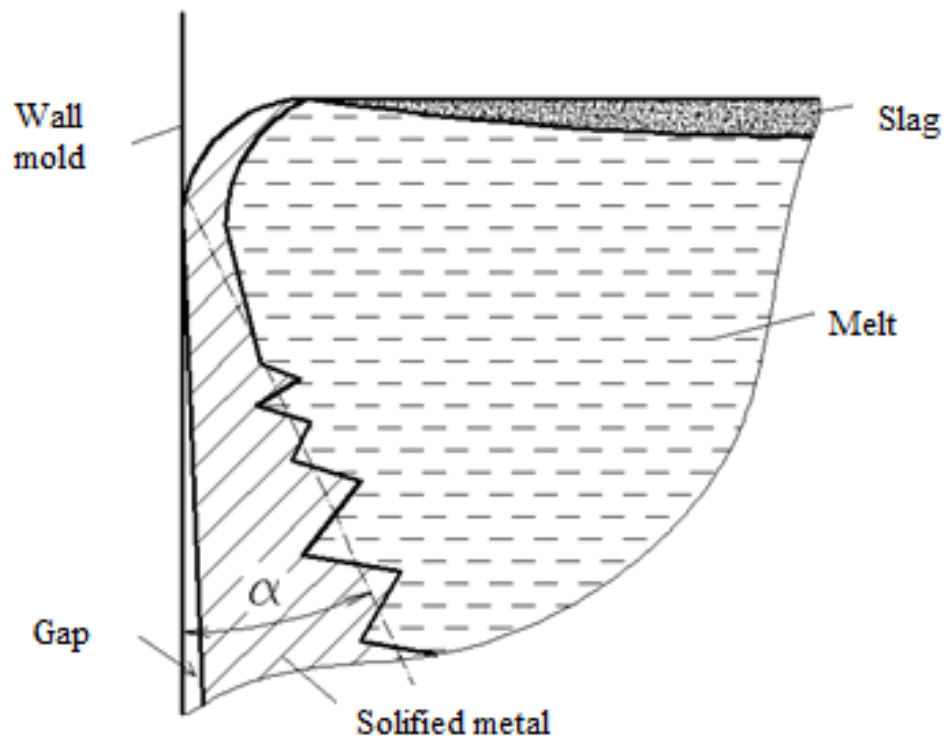

Fig. 13.5 Ingot casting

Rifts cause by high casting speed are oriented transversely. The solidified layer of metal, as shown on fig. 13.5, is distancing itself from the ingot mold wall due to the effects of shrinking. At high casting rates, the solidified layer is too thin and its width is irregular; it can break due to the high pressure of the liquid metal. The casting rate should be adjusted to the metal temperature. At high temperatures, when the metal solidifies more slowly, the casting rate should be lower, at lower casting temperature, the casting rate should be higher.

Gravitational rifts form when the metal is left “hanging” in the ingot mold, as shown on fig.13.6. This occurs most commonly when the metal flows into a joint between the top attachment and the body. It solidifies instantly and creates a collar of sorts where the ingot is kept hanging. The length of the ingot is decreased due to the shrinking of metal during solidification. Gravitational rifts have transverse orientation and are usually near the top. They can usually be burned.

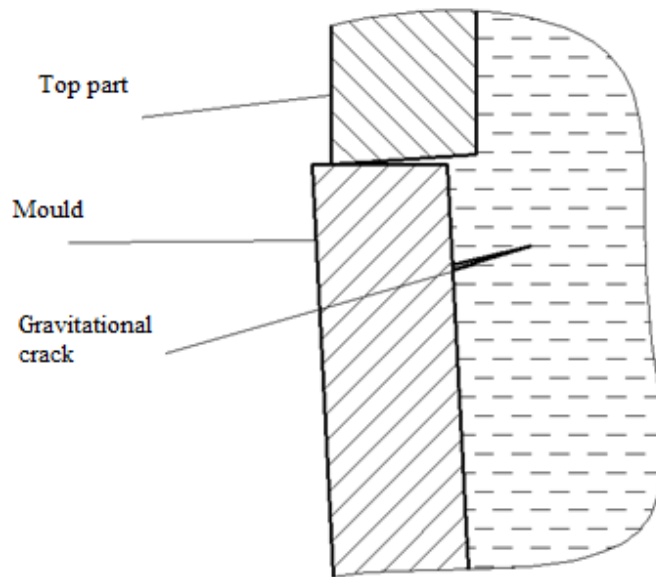

Fig. 13.6 Formation of gravitational rift

Rifts formed by irregular cooling are formed as is schematically shown on fig.13.7. Isotherms are represented for two cases of ingot solidification. If for example during the casting from above, the current of metal moves towards one side of the ingot mold, the hottest metal is off the axis. During solidification, there is a hotter spot on the surface. However, there are tangential tension pulls occurring on the surface due to the effects of shrinking. At higher temperatures, when the material is plastic, these tensions are eliminated by plastic deformation, at lower temperatures, the ingot cracks. In casting from below, this mechanism is improbable.

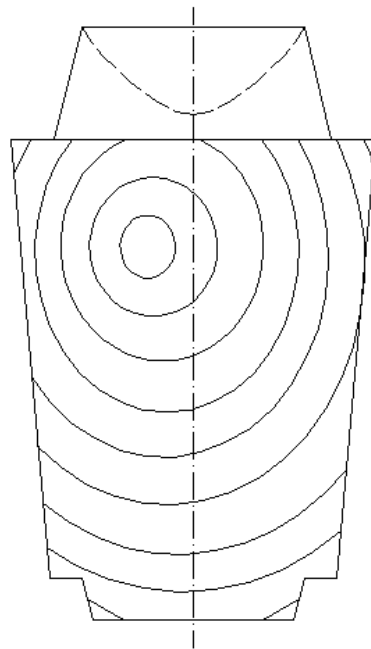

Fig. 13.7 Example of irregular cooling of ingot due to eccentric casting

A different example of irregular cooling is putting the ingot after stripping onto metallic trays. In the tray area, the outflow of heat is much higher, which again creates a gradient which can lead in some brands of steel to cracks.

Another case is solidification of metal inside the ingot mold, where the gap between the ingot mold and the top attachment is covered by heat-resistant material. This spot cools at a significantly lower rate during solidification, because the heat-resistance material isolates heat. Due to a significant difference between cooling rates, a strong tension occurs, which can lead to disintegration.

Mapping and welding flanges form during casting into used ingot molds. These ingot molds undergo a strong thermal strain during casting, which is exhibited in a network of cracks and indentations on the inside area. If the damage reaches a certain level, it is shown on the surface of the cast ingots.

Cracks formed during cooling are smooth, parallel to the axis, usually pass through the heel and are quite deep and they mean the ingot will be dismissed. They are formed primarily in alloyed steels - e.g. for tools - due to fast solidification.

13.3 Inner defects of ingots

Forged ingots usually have large dimensions which means segregation processes are highly developed in them. The ingot structure is shown on fig. 13.8.

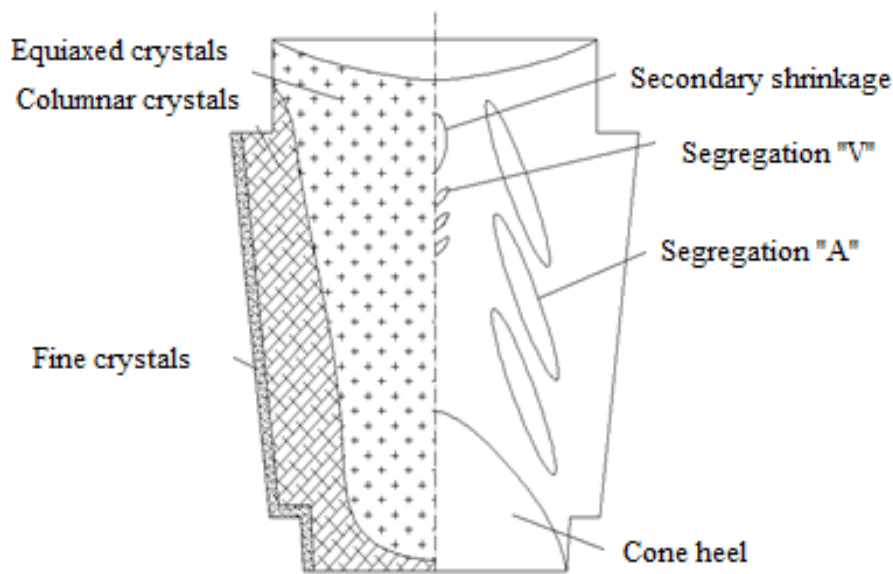

Fig. 13. 8 Structure of a forged ingot

There is a layer of soft crystals on the surface formed by quick cooling of metal in contact with the ingot mold. Then comes a layer of crystals elongated in radial direction, i.e. in the direction of heat outflow. In the middle, there's an area of large equiaxed crystals. There are defects in this basic structure. These are V-segregations in the axis. If the ingot is of suitable geometry, V-segregations do not occur. Suitable geometry means slimness of about 1 and sufficient bevel of the body, as is shown on fig.13.9.

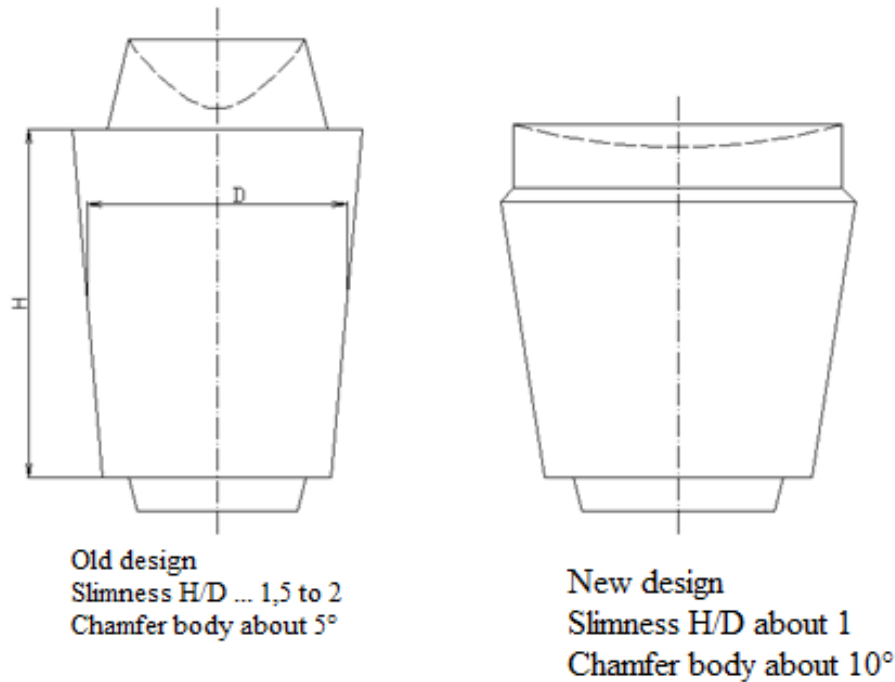

Fig. 13.9 Geometry of a forged ingot

The shrinkage under the top also does not occur if the ingot has a well-insulated top and isolation dusting of the surface is used. In this case, even the primary shrinkage is small. A-segregations can have high range. Their formation is related to volume changes in the moment of solidification. Volume changes during solidification are related to chemical composition of steel. If the steel has minimum amount of silicon, the change of volume during solidification is small and the amount of A-segregations is small. Occasionally, cavities under the surface may occur. These are cavities close to the side surface of the body. They are the result of chemical reactions which occur after casting. Most commonly it is the reaction of iron oxide with carbon



It may happen in case that the steel is not calmed enough, however this should not happen in forged ingots. A more common reason is rusty or unclean inner surface of the ingot mold. These subsurface cavities are most dangerous. Axial cavities - if they occur - are easily closed during forging, subsurface cavities are easily torn and exhibit themselves as surface defects.

13.4 Defects in continuous castings

Continuous castings, or blooms, have a diameter of 520mm in our country, abroad they are cast to a diameter of up to 600mm, rarely are they bigger. Rectangular blooms are also cast. At higher diameters, there is a higher danger of axial discontinuities, which are related to shrinkage during solidification. Lateral cracks are often related to bloom bending in the area of secondary cooling. Lastly, spider web-like cracks may appear on the surface. The reason for their appearance is not sufficiently explained. It is probable that the reason is the decreased strength of grain boundaries due to melted copper from the crystallizer. Steel pollution also acts negatively, especially in case of tin, antimony, bismuth and arsenic, which also weaken the grain boundaries. These elements appear in higher levels in steel made from communal scrap.

13.5 Defects on rolled intermediate products

They can be either superficial or subsurface defects which come from the original continuous casting, but they are of a more elongated shape than the original defect due to elongation during rolling.

Furthermore, relocations and longitudinal “lampas” may appear, they originate during rolling. However, these days it is possible to ask the rolling mill to supply pipes without inner or outer defects. The additional cost for increased quality is worth it, because it eliminated any problems with the forgings.

13.6 Cracks forming at heating

During heating, tensions also occur and if the heating is fast they can achieve such level that the consistency of the material is damaged. This can occur in some alloyed steels. During heating, the grain grows. If it is kept long at the maximum forging temperature, it can overheat - i.e. the grain dimensions are too big. Impurities, which are on the grain boundaries are then more distinctly concentrated and this is the danger of overheated steel. Such material can be forged, but very carefully in small decrements, otherwise, the integrity is threatened.

When the upper heating temperature is exceeded, the scalings begin to grow along the grain boundaries inwards and up to significant depth. Such steel disintegrates during forging.

13.7 Defects formed during forging

Several influences take part in formation of cracks during forging. These are schematically shown on fig. 13.10.

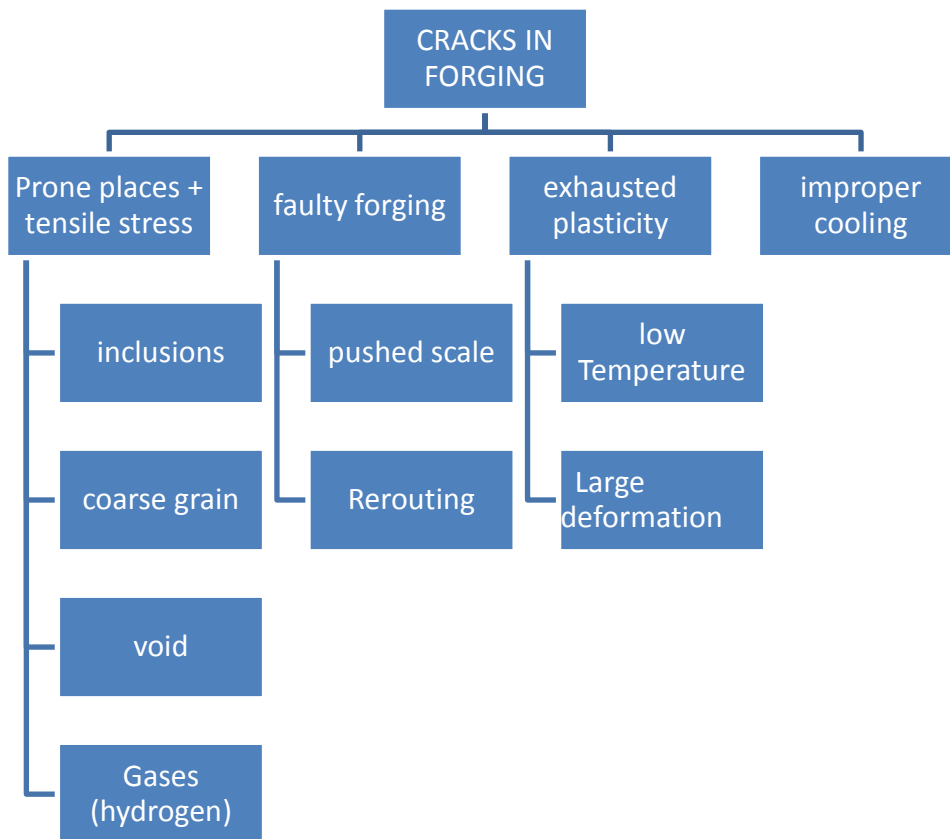

Fig. 13.10 A schematic of influences acting upon the formation of defects during the forging

Elongation is characterized by a decrease of Δh and stroke length l_z . Relative decrease is an important quantity:

$$\varepsilon = \frac{\Delta h}{h_0} \quad (2)$$

as well as the relative stroke length $\lambda = \frac{l_z}{h_0}$ (3)

Tensile stresses can also be dangerous. They occur during elongation on the axis and on the surface close to the edge of the anvil, as shown on fig. 13.11.

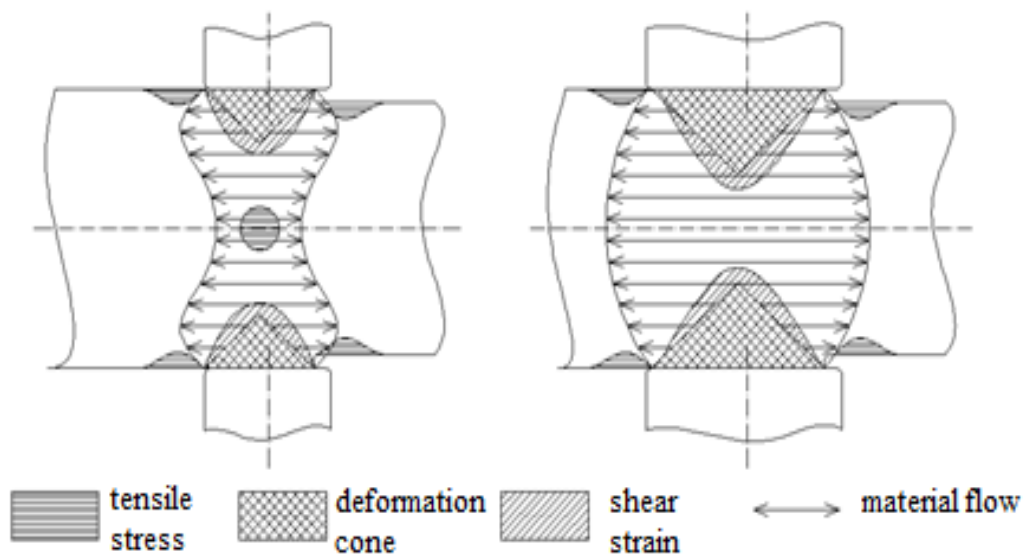

Fig. 13.11 A schematic of stress distribution during elongation by a small relative stroke length (left) and large relative stroke length (right)

Tensile stress occur in the axis as well as on the surface near the edges of the anvils. Axial tensile stress can be limited by choosing a suitable stroke length of 0.4 - 0.6. It is even enough for one of the anvils to be wide enough. Tensile stress on the surface acts at all times and causes elongation of even small surface defects. A schematic of stress distribution during stamping is on fig.13.12. The area of tensile stress is again in the axis and tangential tensile stresses appear after the ingot becomes barrel-shaped.

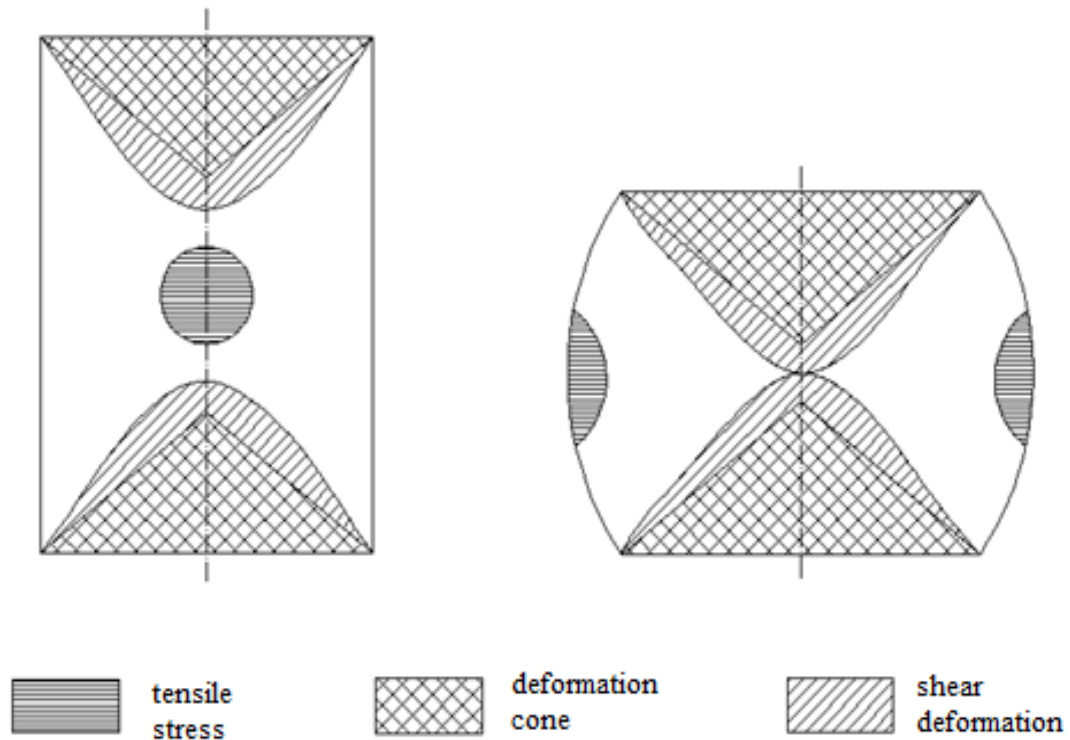

Fig. 13.12 Schematic distribution of stress during stamping

Other defects which may occur during forging are related to depletion of plasticity. Let us remind the reader that the material can also bear some deformation, depending on the temperature. A consistency failure occurs most easily in the area of highest shear deformation. It is the so called a forging cross. It forms in less malleable materials during elongation using anvils that are too wide.

During elongation of materials, which have narrow range of forging temperatures (steels with high content of carbon - tool steels), cracks are formed on the edges. These cool faster and easily move under the forging temperature.

The solution to all aforementioned problems cause by elongation may be equipping the press with a device for fast change of anvils. During elongation, anvils may be gradually changed for narrower ones, which means the metal is elongated with a suitable stroke length. It limits the range of tension stress on the axis as well as the danger of the formation of a forging cross. In less malleable steels, angular anvils may be used and V-die may be used and thus cracks on the colder edges are avoided.

Relocations may also be counted among the discontinuities formed during forging; they form when the product is elongated with large decreases with low relative stroke length, as seen on fig. 13.13.

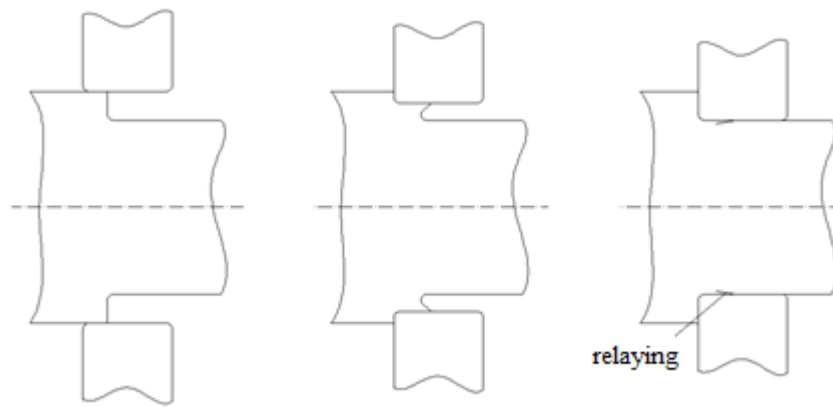

Fig. 13.13 A schematic of relocation formation due to wrong elongation geometry

If the anvil has a large radius of the edge camber, the relocations are not formed as easily. The device for fast exchange of anvils may help solve this problem as well. At the onset of the elongation, anvils with large radius of edge camber are used; in the final setting, anvils with more angular edge are used.

Pressed scalings may also manifest as surface defects. During the forging, it is necessary to take into account their removal and remember that in some brands of steel, scalings cling to the surface.

13.8 Removal of defects during forging

Superficial defects which occur during forging can be removed through burning by oxygen. In some alloyed materials, this is not suitable; for one, the stress caused by the burning causes further growth of the defect inwards and the slag in chrome-alloyed steels is very dense and is difficult to blow out. Therefore, defects are cut out of these steels using processes shown on fig.13.14. It is done either by a bent chisel or a piercing thorn.

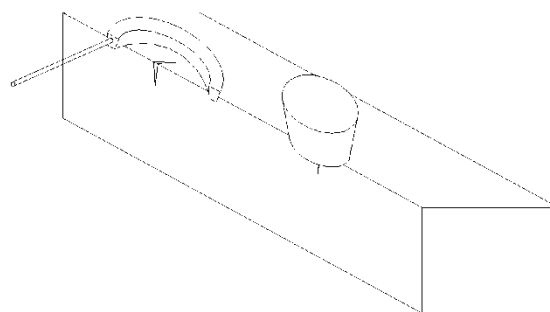

Fig. 13.14 The process of cutting out the defects by a bent chisel and a piercing thorn during the forging of alloyed steels

13.9 Defects formed during cooling

Tension occurring during cooling may lead to integrity failure in forgings. Therefore it is necessary to gradually cool the forgings of great diameter and forgings from alloyed steels.

Special attention has to be paid to the danger of flakes formation. The hydrogen solubility limit in room temperature is significantly lower than at heat. At the temperature of austenite disintegration, the solubility of hydrogen decreases steeply. Hydrogen that is released causes tension and leads to fracturing. Flakes form at a temperature of about 300°C, mostly several hours after cooling, sometimes even several days after.

An acceptable amount of hydrogen depends on the amount of impurities, primarily sulphur. Solubility of hydrogen is higher in sulphur, the impurities then act as “traps” in which the hydrogen is captured. According to some opinions, the dependence looks as shown in fig.13.15.

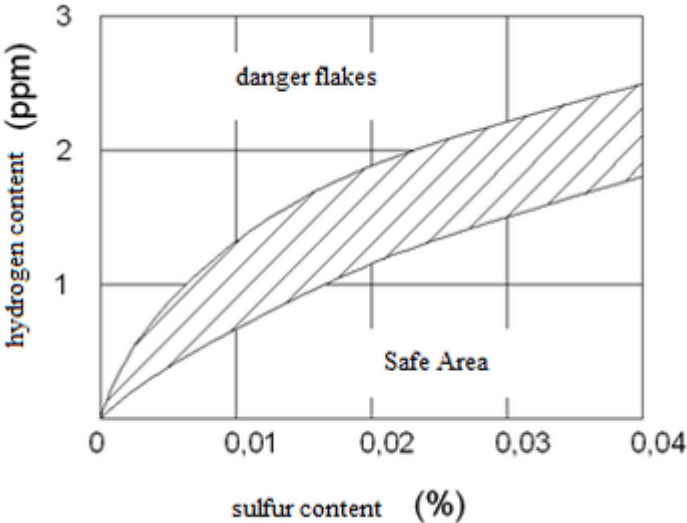

Fig. 13.15 Danger of flake formation dependent on the content of hydrogen and sulphur

The validity of this diagram is questioned by many - who say that many forgings with higher hydrogen content than shown on the diagram do not break.

For flake formation or fractures in segregations, higher content of hydrogen as well as tension stress is necessary. This is proven by an experiment shown on fig.13.16. In rolled continuous castings, flakes of air are formed during cooling. If the continuous casting is placed on two trays at 400°C and weighted in the middle, flakes form only in the strained areas. During the cooling of forgings, strained areas are along their axis.

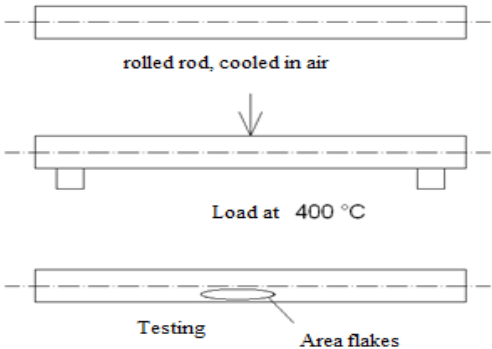

Fig. 13.16 Influence of tension stress on flake formation

13.9 Quenching fractures

There are significant tensions during quenching which may lead to integrity failure. This may occur most easily in places where tension is concentrated, i.e. at the notch. This has to be taken into account, when large forgings are quenched in roughed state. Then it is necessary to choose a suitable medium for quenching and thus a suitable rate of cooling.

The integrity failure occurs especially in the area of martensitic transformation, where transformation stress caused by a transformation of austenite into martensite is added to the tensile stress. From this point of view, a solution of polymers is a suitable medium for cooling, because the rate of cooling is slow.

13.10 Summary

It is not without interest to remind the reader that the acceptable size of a defect has become much stricter over the years.

From the aforementioned enumeration, it is clear that there is a whole range of causes of integrity violations in forgings and we haven't even mentioned all of them. It is also necessary to mention that most defects can be avoided by a number of preventive measures beginning from a choice of suitable steel production technology and ingot or bloom casting and ending with a suitable method of thermal processing.

To investigate a cause of fracture, it is usually necessary to take a sample for metallographic research as well as a record of technological production methods. In some cases, chemical analysis is also needed.

Questions:

1. How can we characterize basic ingot defects?
2. Using what methods may be remove defects of the input intermediate products?
3. Which defects form during heating and cooling of forgings?
4. How do you define the ideal stroke length?

Problems to solve:

1. Draw imperfections of casting structure in large forged ingots.
 2. Determined the options for lowering the number of defects in forgings.
-

14. Consumption of energy in forges

Chapter division:

- Energy demands of forge operations
- Consumption of energy based on forming machines
- Influence of forging technology and temperature on energy consumption
- Infrared heating in forges



Time for studying this chapter: 120 minutes

Aim: After studying this chapter

- You will be able to determine energy consumption for basic forge operations
- You will be able to choose optimal forging technology
- You will be acquainted with the possibilities of infrared heating in forges
- You will be able to judge energy demands of forge technologies abroad



Presentation

In the presentation, an analysis of energy consumption in forges is performed and factors are examined which have influence on this. Attention is focused on the influence of technology parameters during heavy pressing.

14. 1. Introduction

Energy costs are a significant item in production costs and have a tendency to keep growing. In forges, they represent 5-25% and have a tendency to grow. Therefore, the forge workers work on limiting the energy demands and research tasks are being solved - an activity supported by state or European funds.

14. 2. The growth of energy prices

The prices of steel have barely been stabilized (the price of copper has been on the rise lately), the danger of growing energy prices is here. “We are one again on an energy crossroads” or “Let’s find a way to stop the bleeding” are phrases used by foreign commentators who write about this danger. In the United States, some say the price of natural gas will rise by 100%.

As a remedy to this, many solutions are proposed; two pieces of advice dominate. One turns towards the industry and is: Let’s use all available preventive measures to lower energy consumption. The second one turns to politicians and economists and goes: Let’s build an economy of effective energy. They refer to the fact that during the energy crisis of 1973, Japanese government made this statement its program and after three years, the energy consumption really did fall in Japanese economy. We should focus on the first piece of advice. The ways are known. Consistent use of thermal exchangers in all gas-heated furnaces. We must remember that ceramic recuperators have great leaks and are not as effective as the metallic ones. In induction heating, the energy consumption can be optimized by a correct choice of the induction coil size and use of suitable frequency. Some regimes of thermal processing, especially in big forgings, are inflated - they can be shortened. Optimization can be helped by mathematical modelling. In die forgings, directed forging and cooling can completely remove thermal processing. The heat of the cooling material can be used to heat building or water and save money on gas.

14.3 Energy consumption of individual operations

An example of energy consumption for production of die forgings is on fig. 14.1.

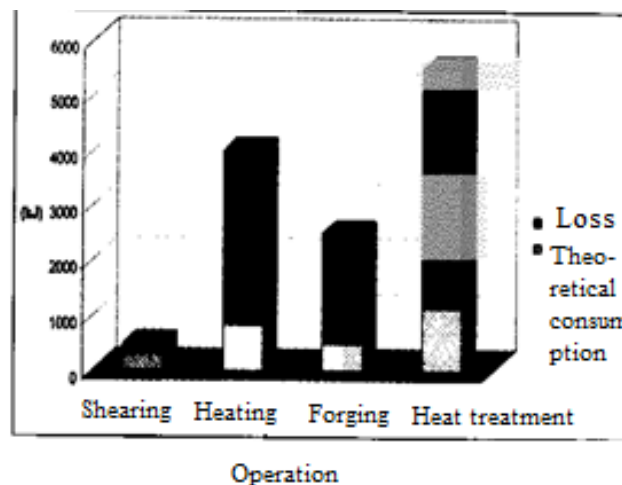

Fig. 14.1 Consumption of energy for production of 1kg of common die forging

It is a case of forging in one cavity on a crank press after forging comes quenching and tempering. The energy consumption is strongly dependent on the type of forging, forging technology, state of the device, etc. In general, most energy is demanded by thermal processing and heating. It is true, that effectiveness of all forging operations is very low.

14.3.1. Consumption of energy in heating and thermal processing

Balance of gas-heated furnace is schematically shown on fig. 14.2.

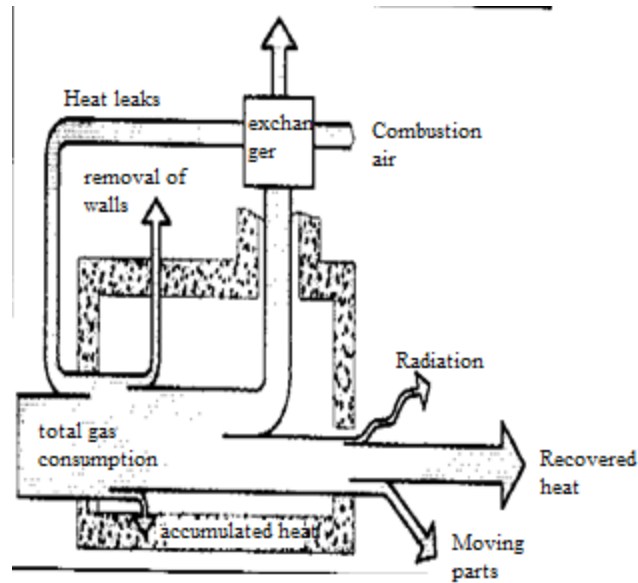

Fig. 14.2 A schematic of energy consumption balance for gas-heated with heat exchanger

The main heat loss is represented by heat carried away by flue gases. In using a recuperator or a regenerator, in which air is heated for combustion, part of this heat may return into the furnace. Other losses are represented by heat accumulation in walls during the heating of the furnace. During constant operation, this item does not apply. Heat loss through movable parts forms e.g. during thermal processing of die forgings in baskets. Loss through heat radiation depends on the proximity to the furnace. The amount of heat flowing out through the walls depends on the type of wall lining. Characteristics of the lining materials are shown on fig. 14.3.

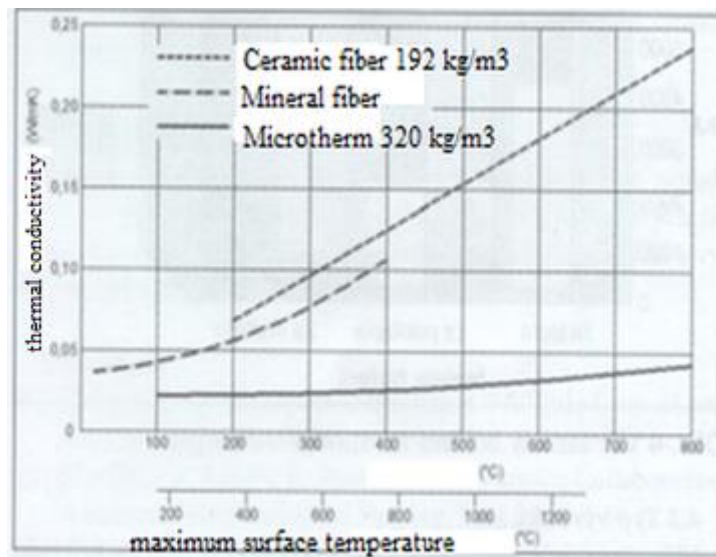

Fig. 14.3. Thermal conductivity of individual materials depending on temperature

The diagram shows dependence of the thermal conductivity coefficient in dependence on the average wall temperature and the maximum temperature on the inner surface. The Microtherm material has the best isolation properties has, which contains microscopic pores

filled by air. Air is - as is well-known - a good insulant, but only if it cannot flow. Fiber materials have slightly worse isolation properties, which also trap a lot of air between the individual fibers. Thermal conductivity of fire clay, refractory concrete and other lining materials are much higher.

In the United States, as a part of an action to conserve energy, a pusher furnace has been put into operation, which serves to heat up continuous castings in dimensions of 160x160mm and 12m long. Continuous castings are heated up to 1100°C. There are 3 lines of burners on the top and 3 lines on the bottom of the furnace. Air pre-heated to 442°C is used, the outgoing flue gases are 758°C, a 5% surplus air is burned. The effectiveness of the furnace is 65.8%, flue gases carry away 29% of the energy put in, 0.7% of the energy leaks through the furnace walls and 4.5% of the energy leaves in the cooling water. Germany is also working to construct an energy-saving chamber furnace for forges. Effectiveness of usual furnaces is much lower.

14.4. Organizational precautions

Apart from technical precautions, attention also has to be paid to organizational precautions which usually do not require any investments and can lead to significant savings. Primarily it is necessary to:

- Fully utilize the furnace capacity
- Work in more shifts
- Use the basket as little as possible in thermal processing
- Make sure the furnace is in good state and well regulated

In uninterrupted operation of the furnace, there are large losses through heat accumulation, especially in case the furnace has a traditional (fire clay) or similar lining. If the furnace is in bad technical state, it usually leads to increased fuel consumption.

14.5. Influence of press type

Energy consumption during forging is dependent also on the type of press. The lowest consumption at given power has screw press with direct drive. Second is the crank press and the third is friction press. Hydraulic press consumes 10 times more energy than crank press.

The analysis of work performed by crank press showed that from the input energy, 77% is used for the shaping work. The highest loss of 6% is due to friction in the connecting rod, 5% of energy is lost in crank deformation. Other losses are negligible.

In hydraulic press, the energy consumption depends on the type of drive. In accumulator drive, the press always works with maximum pressure. If the shaping force is significantly lower than the nominal one, there are losses occurring. In direct drive, energy is lost in case the speed of crossbeam is markedly decreased due to high deformation resistance. Energy supplied by the pump is changed into heat which causes the heating of hydraulic liquid and requires cooling. A decrease in speed occurs only at the end of each forging cycle, pumps however take the same power at all times. A drive called UNiGY has been developed in the United States. It was installed in an American forge Consolidated Industries in Cheshire, where a hydraulic press of 25 MN works on die castings. This press is 50 years old. The

electricity consumption was lowered by 66%. New pumps allow for a more economical operation at variable through-flow.

14. 6. Influence of forging technology

When free forging is concerned, technical equipment of the workplace does not allow for great variability of the choice of technology. Wider options are in heavy pressing, where more variants are available which require different forming forces and thus different energy consumption.

14.6.1 Forging temperature

A general rule in choice of forging temperature is that lowering the heating temperature saves energy on heating but the energy consumption of forming is increased. A summary energy consumption is lower at lower forming temperature. This is shown on fig.14.4.

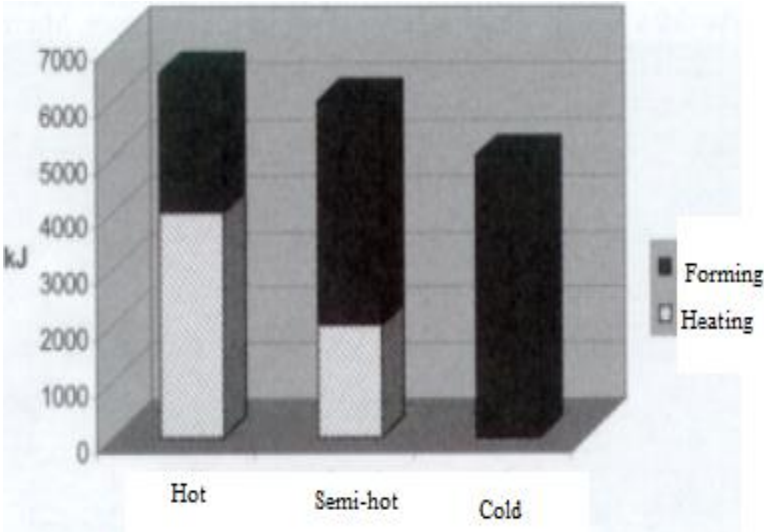

Fig. 14.4 Influence of forming temperature on energy consumption

14. 6.2 Type of collar

The influence of different technological variants will be shown on an example of forging in shape of a mushroom. During forging in vertical position, when the heat is formed by stamping, we can choose different types of collar, as is shown on fig.14.5. The most common radial collar increases the contact area twofold and we know that the forming force depends on the contact area. Axial collar or forging in an enclosed die does not increase the contact area and is energetically more suitable.

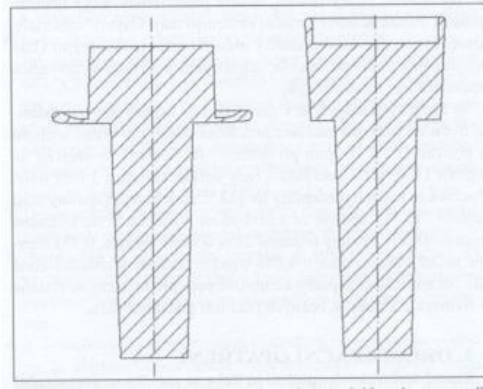

Fig. 14.5 Forging in shape of a mushroom forged in vertical position with radial (left) and axial (right) collar

14.6.3 Forging a twin-piece

The influence of forging a twin-piece will be shown again on a case of mushroom-shaped forging in horizontal position. Many variants are applicable, as shown on fig.14.6.

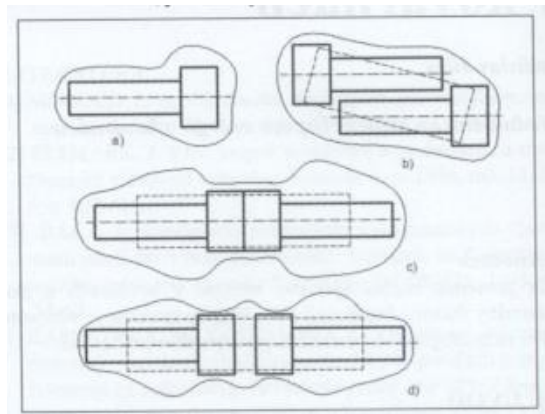

Fig. 14.6 Variants of forging a mushroom-shaped piece horizontally a) a solo piece, b) a twin-piece, parallel offset c) twin-piece, equiaxed connected, d) twin-piece, equiaxed, separated

Consumption of energy in these processes is shown on fig. 14.7.

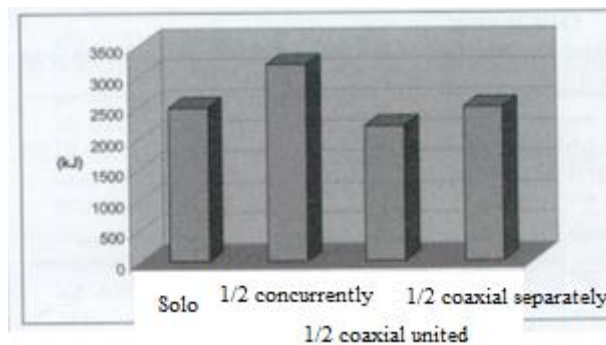

Fig. 14.7 Consumption of energy in forging a twin-piece

Here we have a comparison of energy consumption of forging a single piece with one half of consumption when forging a twin-piece. The consumption of forging a twin-piece with the parts laid out parallel to each other is highest. The consumption of forging the pieces in equiaxed position is almost the same as forging two single pieces. When the pieces are in parallel and offset, the flow of material is made difficult, as shown on fig.14.8.

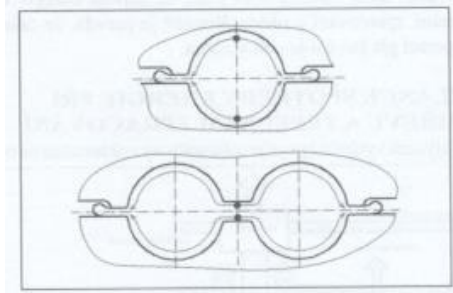

Fig. 14.8 Cross section with a schematic marking of the material flow in parallel and equiaxed twin-piece forging

The axial collar can be cut away by cutting the bevel along the radius of the head.

It is clear that in a twin-piece with parallel offset, the material flow during forging is much more complicated than in an equiaxed piece or in a solo piece. The whole process has to be judged complexly. The consumption of metal has to be taken into consideration as well as consumption of energy. In forging a parallel twin-piece, the heated block can be put directly into the die, in the two other cases, pre-forging is required (as well as in case of the solo piece), or otherwise there is a lot of waste (as is shown in the equiaxed twin-piece). In case of the connected twin-piece, there is also the subsequent separation to consider.

14.6.4. Extrusion

The mushroom-shaped forging can also be produced through extrusion, as shown on fig.14.9.

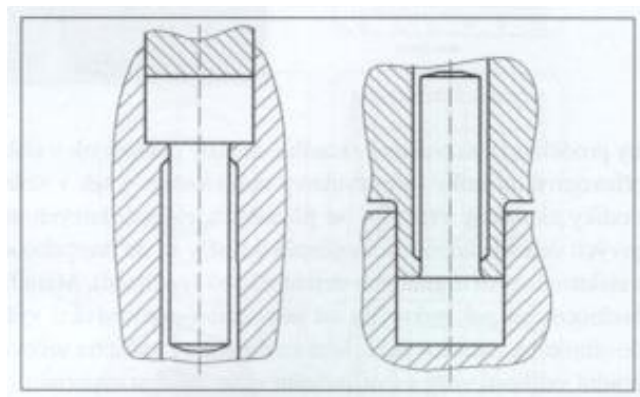

Fig. 14.9 Production of a mushroom-shaped forging by extrusion. Left is forward extrusion, backward extrusion on the right.

In forward extrusion, the energy consumption is higher than in backward extrusion. In forward extrusion, the column of metal is moved through the stack, which creates high pressure and the friction on the walls is high. Production of this type of forging by backwards

extrusion is - however - more complicated. In both cases, the energy consumption is higher than in forging it in a die vertically by stamping.

14.7. Other options for energy saving on forges

We will state some other tips for energy conservation in forges which have been proven. Therefore it is not just theoretical advice.

- In free forging of pipes, the isolation panels can be placed around the product or an isolation sleeve can be placed upon it. The material cools more slowly and this saves on heating.
- Biogas can be used for heating the furnace instead of natural gas. Its use is much more common abroad than in our country. It is usually used for boiling water or heating. There is also a small power plant that burns biogas.
- By putting in heat-exchanging pipes, the heat from the flue gas after the recuperator is used as well as the heat from the forgings.
- By using micro-alloyed steel and directed cooling, we can save on thermal processing. This solution requires an agreement with the constructor.
- Using the cooling water from induction coolers to heat buildings.
- If possible, use continuous furnaces for heating and thermal processing.
- Automatic regulation of compressors may bring energy savings in forges working with power hammers.
- Heating of the dies in resistance furnace or infrared radiators is more conserving than their heating using gas burners. It is also faster and more precise. In small dies, induction heating should be considered.
- Quenching from docking temperature and tempering by inner heat is applicable for some types of forgings. Quenching from docking temperature is applicable in aluminium alloys.

Complex approach to energy saving can have a significant effect. In some areas of Britain, 10-30% of energy savings have been achieved.

14.7.1 Introduction of infrared heating of aluminium alloys before forging

Aluminium alloys are commonly heated in electronic furnaces, in muffle furnaces, in oil furnaces, through induction, in furnaces with fluidized bed and through resistance. Aluminium alloys have relatively narrow range of forging temperatures and require high precision of heating, often ± 5 °C. The effectiveness of heating furnaces is low, it does not exceed 25%. Infrared radiation heating seems like a good solution here. The heating element is a tungsten halogen lamp which heats up in less than 1s and gives a higher density of energy flow by an order, which means 20-40 W/cm², whereas it is 2-4 W/cm² in regular heaters. One device is suitable to heat up different types of intermediate products, there is no need to change any parts as it is in induction heating. For laboratory tests, a panel with area of 0,6 m²

and power of 88kW was used. It heated pipes made from alloy 2014 with radius of 23 millimetres to a temperature of 425 °C. Pipes were heated after 6 minutes.

Then, operational tests have been performed. In the foundry there was a furnace with gas infrared heating and blocks weighing 0.26kg were heated. The heating time was 13 minutes. There is also heating in a gas-heated furnace, where the heating times were even longer. By using electrical infrared heating, the period was shortened to 3.4 minutes. The test forgings were cut open and metallographic tests were performed. It has shown that the forging forged through electrically infrared heating has significantly smaller grain. Other samples were taken after the thermal processing. The difference in grain size was even more pronounced.

Energy balance showed that in the electrical infrared heating, much less energy has been spent than by heating in a conventional furnace.

Microwave furnace used in common production has several halogen lamps placed on the top and bottom and the time of heating is significantly shorter than in a gas furnace. For example in heating a block 87mm in diameter the heating time was shortened from 60 minutes to 20 minutes. The energy consumption is 40-50% lower. In contrast to induction heating, the furnace is universal; it can be used for different shapes and sizes of products. The use of industrial infrared radiation began in the 1930s in burning paint on cars. Later it has been used in processing other types of coatings, in plastics processing, in paper drying, in the food industry and many other fields. In the United States, an effort is made to widen its use. IHEA (Industrial Heating Equipment Association) published a handbook focused on infrared heating.

This device has been also used in die heating. The die of dimensions of 305 x 355 x 165 mm was heated to 300 °C in 20 minutes.

The device for infrared heating was in operation at one forge in proximity of power hammers for 11 months. Only two of the 12 installed lamps needed to be changed, each costing 40 \$. However, metals are good conductors and during microwave heating, electrical arcs jump to them. When using low-pressure plasma, their formation is prevented and various parts can be heated using microwaves.

The main advantages of electrical infrared heating are::

- lower investment costs
- lower operational costs
- simpler and cheaper maintenance
- tolerates difficult working conditions
- can be used to heat up intermediate products
- can be used to pre-heat dies.

14.7.2 Savings in thermal processing

Thermal processing is a field which exists not only in forging but also in foundries, in welding and a range of other production fields. It is characteristic for high consumption of energy and at the same time it has big influence on the resulting utility properties of the products.

Therefore, great attention is being paid to all kinds of improvements which are available here. In the United States, an institute has been founded which is concerned with rationalization of thermal processing. Its first goal is energy conservation. In normal operating conditions, 20% of energy can be saved in thermal processing and the process itself can be shortened by 20%. In designing new processes, limiting deformation in processing has to be considered. Diffusion thermal processing is optimized and emissions are minimized.

Works are also focused on gathering of data from quenching tanks, based on which further improvements can be made. Great attention is also paid to quenching using compressed gases.

The Mexican company FRISA Forjados S.A. de C.V Monterrey, which rolls 120t of rings daily is also focused on rationalization of thermal processing. For thermal processing of rings it has 16 furnaces and six quenching tanks. Each has the volume of 90 m³. The tanks contain water or a polymer solution. The pool have forces currents. The used jets cause the flow of cooling medium at the speed of 0,015 - 0,04 m/s, which has been shown as insufficient. At this speed, the steam pillow is not torn away, which is formed on the surface of parts and decreases the rate of cooling. To tear away this pillow, flow speed of at least 0.3 m/s is required. Originally, the currents were ensured through jets, later water screws started being used instead placed in the corners of the tanks. To lower the cooling rate in the range of temperatures around 350 °C, polymers have been used with higher atomic weight. Another object for rationalization were grates where the rings are placed. Their lifetime was only a few months. The steel grates weighed 3000kg. They were changed for grates made from light alloy weighing 1000kg and which were in good after 14 months of service. These rationalization measures led to a yearly production of 18000t of rings and savings of 720 000 dollars. The increasing interest in rings led to extension of the device for thermal processing.

14.7.3 Energy savings in forges abroad

In western countries energy prices rose sooner than in our country. Their forges were forced to look for energy savings. Some successful solutions have been published.

One of these forges was Jernberg Industry in Chicago. This forge was founded in 1937 and is said to be the first commercial forge which used crack presses for heavy pressing. Today, over 70 thousand tons of forgings are produced here primarily for cars and motorcycles.

The factory has seven cutters for separation of outgoing pipes. They are cut after pre-heating. The work is done on ten forging lines, cutting is done on separate presses. Around half of the forgings are thermally processed. In the past, five furnaces were used in which the forgings were processed in batches. This was inefficient, the production cycle was too long. Therefore the production was moved to continuous furnaces which saves a significant amount of gas.

Other savings were introduced with the repairs of faulty recuperator. The cooling water from induction heaters which used to be cooled in outdoor towers was tasked with heating buildings which used to be heated by natural gas. Costs for this reconstruction amounted to 25,000 dollars, yearly savings on gas heating was 23,700 dollars, the investment was recuperated in 1.1 year.

Furthermore, regulation of heating rate in induction heaters was introduced so that the heated blocks are not cooled before pressing. Costs for this regulation loop were half a million

dollars and yearly energy savings were 4.1 million kWh with 10 production lines, which translates to 247 000 dollars in a year. The investment returned in 2 years.

The station for compressed air production used to be manually operated. By introducing automatic regulation, minimal variations in the compressed air pressure have been achieved and this saves 1.8 million kWh of electrical energy every year.

Further savings have been achieved by a wider use of micro-alloyed steels with controlled air-cooling.

Further savings were introduced by change of used compressors. The final measure which was made was the change of die heating after their change. They were originally heated by gas, the time of heating was about 20 minutes. Instead, infrared ray heating was used for dies which then reached their operating temperature in 4-5 minutes. The price of an infrared heater was 5000 dollars; it paid for itself in 0.7 years thanks to the saved working time of the press. Overall yearly savings achieved through the realization of the project were 791 thousand dollars; the cost of the project was 2 million dollars. Second example is American company Mataldyne. It created a team of people in its Royal Oak foundry which would look for possible energy savings.

It is worth noticing that the work of this team was financially supported by the American Department of Energy. From the overall costs of the work - \$200 000 - the DoE paid \$100 000. Natural gas was used in the foundry for boiling water, heating and air conditioning and partial heating of some furnaces; electricity was used for other purposes. The main production machinery is the forge hot automatons Hatebur, presses for forging at medium heat, presses for forging at heat and ring rolling machine. 21 measures were introduced overall. Here are the main ones:

The pneumatic drive of the ejectors of some presses was adjusted so that energy-efficient nozzle was used which decreased consumption of compressed air.

There are eight induction heaters in the foundry. Each one is comprised of various components and there are empty spaces between them for maintenance. These spaces were covered by isolation with windows.

For forgings and rolled rings which are sent for thermal processing to an external contractor, controlled cooling in baskets was introduced which ensures even colling of all parts.

Modernization of die clamping and use of automatic locator of dies allows for shortening of the time necessary for exchange of tools and thus also the downtime.

The foundry had a one-month stock of material in its warehouse. The team recommended to lower this stock by 50%. This required several organizational measure. For example each type of forging had a minimum and maximum required stock of input material. It also decreased the size of minimal delivery series.

Stocks of finished products were also decreased, which were often also unsuitable stocked in the courtyard.

Several measures were introduced such as ionic nitration, which lead to increased lifetime of the tools used.

14.8. Summary

It takes effort to decrease the energy consumption in forging production, but it is possible. Apart from some isolated actions in individual factories, it would be suitable to find possibilities of collective solutions with the use of societal resources.

Questions:

3. How would you characterize the influence of the forging process on energy savings?
 4. What energy saving options are there in free and die forges?
 5. How is energy saving performed in foundries abroad?
-

15. DIE FORGING PERSPECTIVES

Chapter division:

- Industrial use of die forgings
- Intermediate products and their heating
- Forming machinery and forging lines
- Robots, manipulators and tools
- Quality of forgings and ecological problems of forging



Time necessary for study: 120 minutes

Aim: After studying this chapter:

- You will be able to determine rules of die forging
- You will be able to design technological process of forging rotation symmetrical products
- You will acquaint yourself with basic forming machinery in die forging



Presentation

The use of die forgings, quality of the incoming intermediate products - rolled continuous castings and pipes, separation of pipes, heating for forging, forming machinery, die construction, material flow simulation during die forging, use of robots, die forgings for car industry, die forgings for aviation industry, procedural automatons, production of dies, lubricants, thermal processing, die castings from micro-alloyed steels, perspective of die casting.

15.1 Introduction

The expansion of car and aviation industries, roller bearing industry and other industrial fields caused development of die forging. Die forgings are used for the most demanding parts of car engines such as crankshafts, piston-rods, etc. Car industry consumes up to 60% of the produced die forgings. In aviation, they are used for turbine blades. Parts made from die

forgings have high demands on them, such as high resistance to dynamic strain, high creep resistance... Apart from high quality, die forgings achieve higher productivity in comparison with other technologies - they can be five times as productive. The use of the material is increased by 20-80%. Currently, die forgings are made not only from steel but also from copper and other alloys, aluminium and its alloys, nickel, cobalt and titanium alloys. The weight of die forgings is anywhere from a few grams up to several hundreds of kilograms, counter-rotating hammers can weigh 15 tons. In recent years, the use of micro-alloyed steel alloyed by titanium, niobium, vanadium and nitrogen or other elements has increased. The goal of new technologies in die forging is production of very precise forgings with minimum forging additives and narrow tolerances, high productivity achieved through maximum mechanization and use of robotics and meeting ecological demands especially lowering noise and shock levels.

15.2 Initial intermediate product

Steel intermediate products for die forging, especially rolled continuous castings and round or square pipes are supplied in the Czech Republic by companies TŽ Třinec, NH Ostrava, Železářny Hrádek, ŽDB and currently - in smaller amounts - also by VÍTKOVICE HEAVY MACHINERY. These metallurgical companies went through modernization of technologies and production equipment in recent years and therefore the quality of the initial intermediate products - continuous castings and pipes for die forging - was increased significantly. The steelworks of TŽ Třinec, Acelor Mitall and VÍTKOVICE GROUP went through significant modernization. In Vítkovice, the transition included the exclusive use of electric arc furnaces and convertors. Secondary metallurgy brought great improvement of steel quality. Vacuum stations were built as well as equipment for heating liquid LF-type steel and equipment for desulphurization of liquid steel. The goal of vacuuming of steel is preventing the formation of flakes in rolls by a significant decrease of hydrogen content, improvement of mechanical properties of the rolls, improved ultrasound purity of steel; the aim of liquid steel heating in a pan is its refinement, which primarily means decrease of the contents of sulphur, oxygen and non-metal inclusions; the aim the desulphurization equipment is removal of sulphur, thermal and chemical homogenization, treatment of the chemical composition, removal of accompanying elements and modification of irremovable impurities into suitable shapes. In Acelor Mitall and TŽ, transition of technology from ingot casting into block continuous casting was made which brought a significant decrease of costs and increase in quality. In rolled pipes from continuous castings, the degree of forming is important; TŽ Třinec has produces a continuous casting 550mm in diameter, i.e. its rolling mill can work with much more formed blooms and pipes after continuous casting than before. The electric steelworks ŽĎAS, which is also currently an important supplier of tool steel for dies, was substantially modernized. Vacuum degasification was performed as well as vacuum oxidation decarbonization and vacuum ingot casting.

15.3 Division of initial intermediate products

Division of initial intermediate products into separate blanks for die forging is done by a range of technologies and using different separation equipment:

- cutting of blanks on high-speed rotation saws, saw blades are equipped with teeth from sintered carbides. The workstation of material cutting is equipped with a stock of pipes and blank sorting station. The advantage of this technology is achieving perpendicular cut and clean area of cutting at minimum noise,

- grinding, high cutting power, accuracy and perpendicularity of the cut, cut without burrs; there are no structural changes on the separation plane; the separated areas are smooth and clean; disadvantages: the technology is dusty and noisy,
- belt saws underwent significant development, the cutting blades have geometry and gear shape based on the type and shape of the material being cut; electronic control of the cut accuracy, tension gauge checks the tension in the belt, refraction gauge allows for constant control over the composition of the cooling liquid,
- technology of cutting by water ray, laser cutting is used especially in forming cuts of sheets,
- plasma cutting brought great productivity and high quality of the cuts; plasma cutting tools are supplied by the American company Hypertherm,
- thermal separation of blooms and pipes using acetylene-oxygen flame; achieves the higher burning rate and higher power of primary flame from the gases used (propane is also used),
- breaking, technology used in less formable materials,
- cutting volumetrically accurate blanks, the device is comprised of pipe stack, pointing unit, sensory device for measuring deviations of the pipe radius, microprocessor control system, crank press, preloaded cutting tool and automatic setting of stops based on immediate tolerances of the pipe.

15.4 Heating to the forging temperature

Heating of the blanks before die forging is performed using several technologies:

- induction heating; circular or square blanks, which are to be heated to the forging temperature pass through one or more inductors; AC of appropriate frequency passes through these. The blanks move on rails or on skid boards. Each inductor forms one multi-block unit and one line for blank heating can be comprised of one or more inductors. Manipulation with blanks can be entirely mechanized,
- gas heating; the heating furnaces have been innovated recently: the furnace lining formed by ceramic mats based on SiO_2 and Al_2O_3 , new constructions of high-pressure burners, automatic control systems have been installed to direct the heating process, such as system off-on, these improvements contributed to making this form of heating more precise and less costly,
- resistance heating through direct transit of current is at its most effective when the ration of length and the diameter of the heated material is between 6 : 1 - 10 : 1, electrical resistance heating consumes the least energy.

Measuring the temperature of the heated material was also upgraded; currently, thermometers used have measurement tolerance of $\pm 0,5\%$ at temperatures of 1500°C (achievements of the space exploration).

15.5 Forming machinery

Forming machines for die casting have gone through substantial development in recent years, especially vertical forging presses designed for accurate forging of die forgings and calibrating, screw presses, die power hammers, counter-rotating hammers, high-speed

hammers and new types of forming machinery have been created. The basic requirements of forming machines for die forging are:

- high number of working lifts, low contact period of the forging with the die,
- low investment costs, low energy costs,
- accuracy, small forging additives and limit deviations, small or no mechanical processing.

Production of forming machines for die forging has a long standing tradition in the Czech Republic; 2 Czech companies have their long-term place on the world market - Šmeral and ŽĎAS.

Šmeral – the company was founded 140 years ago by Ignác Stork, it was renamed Šmeral after World War II; it produces equipment for die forging, such as - primarily - a range of vertical forging presses (from LMZ 1000 to LMZ 6500); these presses are designed for accurate die forging and calibration of forgings at heat in serial and mass production. The main consumer of these forgings is car industry. Vertical forging presses went through a long development process since the LKM types through LKT, LZK to the modern LMZ type. For example, in the LKM 1000, the production of die forgings was started in a foundry in 1960. At that time it produces famous die forgings for front and back wheels of buses. Fig. 1 shows an example of a die forging forged on the vertical crank press LZK 6300.

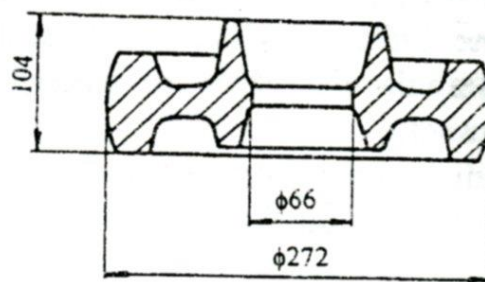

Fig. 15.1. Die forging forged on the vertical crank press LZK 6300.

Another equipment produced by Šmeral are horizontal forging presses, which are designed for forging at heat in one of several dies, pneumatic-hydraulic power hammers, punching presses, automatic transfer forming lines, equipment for transversal crank rolling which rolls - among others - slugs for subsequent die forging. Šmeral produces dies for die forging including thermal processing, ionic nitration, quenching in vacuum and working in quenched state.

ŽĎAS – for die forging, ŽĎAS produces a vertical forging press LMZ 6500, crank presses of a one-point series LKJP, screw presses of the LVE series. Forging set for forging of combustion engine valves with an LVE 400 press with two robots for material manipulation and six stamping machines for stamping the valve heads was recently supplied into Asia. The tool factory produces tools for forming especially for moldings for car industry, dies for die forging; ionic nitration is used in thermal processing.

The advantage of die forgings forged on vertical forging presses is small additives for working and small limit deviations. These are achieved by reliably leading the ram, automatic smoothing of forgings from the die, which allows the use of less bevel, constant height dimensions of the forgings are achieved by constant height of the ram lift.

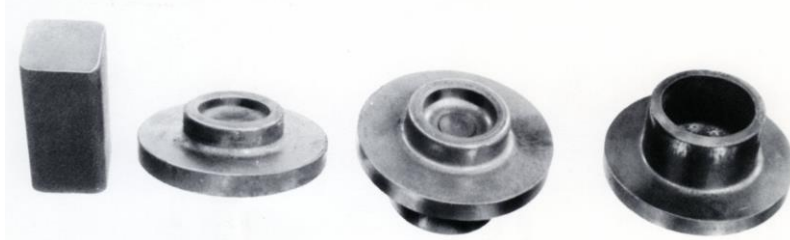

Fig. 15.2 Rotation forgings forged on vertical forging machinery

Even alloys with high deformation resistance, such as Nimonic, can be forged on vertical forging presses. Forging on vertical forging presses is fully automatic which allows to inclusion of forging presses into lines. One of the biggest vertical forging presses which has been built is the vertical forging press of Sumimoto company - it has pressing power of 110MN.

The leading manufacturer of power hammers - the Bêché company - produces various types of die hammers:

- air die power hammers, ram weight of up to 2250 kg,
- short-lift hammers, impact work up to 160 kJ,
- counter-rotation hammers, impact work up to 2500 kJ.

Other manufacturers of die hammers are Lasco, Banning and others. Advantages of die hammers are forging of die forgings with high area in the separation plane.

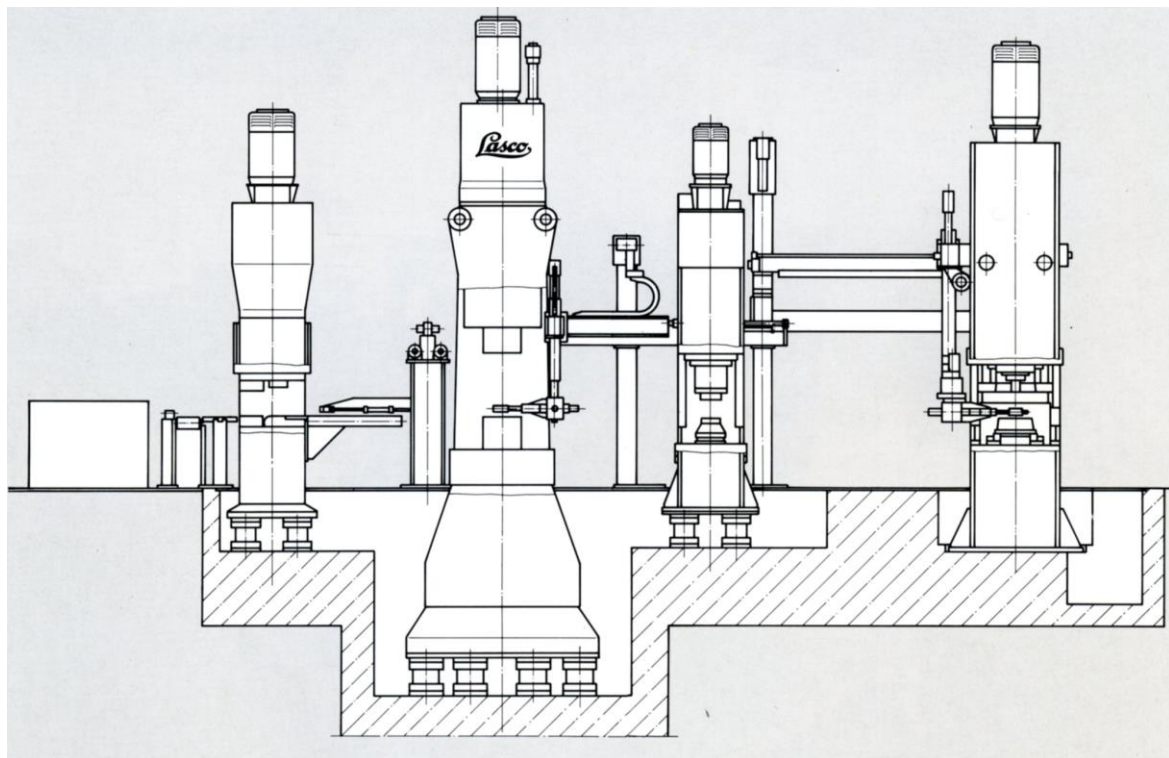

Fig. 15.3. Lasco forging line for forging roller chains for earthmoving machinery

Hammers are controlled by electricity. Fig.15.3 schematically shows an automatic forging line in Lasco company consisting of 4 presses. Manipulation with the material being formed is done using four robots:

1. Electrohydraulic press with pressing force of 6300 kN;
2. Electrohydraulic die hammer with impact force of 160 kJ;
3. Electrohydraulic press with pressing force of 4000 kN;
4. Electrohydraulic press with pressing force of 12500 kN.

The forging line serves for forging of roller chains for earthmoving machinery, the weight of the die forgings ranges from 10 to 65 kg. Technological process of forging the rollers is shown on fig. 15.4.

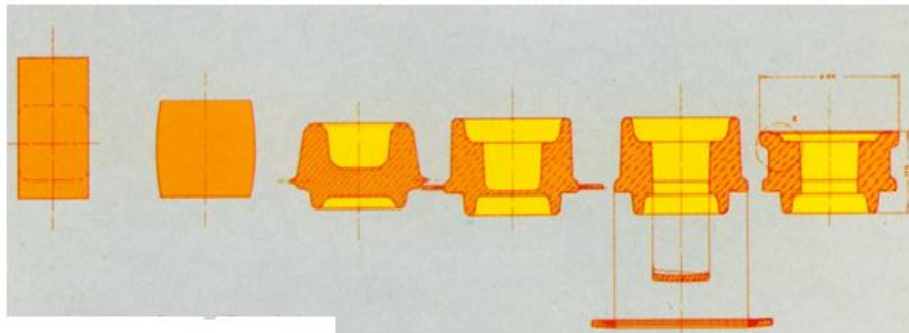

Fig.15. 4.Technological process of forging on a SMS Hasenclever forging line

For die forging of precise forgings of gas blades and steam blades, a screw press was constructed with forming force of 140 MN; the workstation of the press is equipped with carrousel furnace with the middle diameter of 10 000mm, the range of heating temperatures is from 400 to 1300°C. Using the press, die forgings are made from aluminium and its alloys, from alloys and richly alloyed steels, nickel and cobalt alloys and from titanium and its alloys. The workstation of the press is equipped with manipulators with capacity of 240 kg and quenching device for quenching from the docking temperature. The press is driven by six hydro-motors, which drive the horizontal flywheel; the dose of energy is effective within the 10-100% range.

The biggest and heaviest die forgings are forged on counter-rotating hammers and hydraulic die presses. In France, it is a hydraulic press, product of NKMZ with pressing force of 750 MN; it produces crankshafts, turbine runners, die forgings for aerospace industry. The biggest counter-rotating hammer is installed in the USA; die forgings of up to 15 tons are forged with it.

15.6 Forging lines

Technological processes of die forging are always being developed, shapes of die forgings are becoming more complex; this is why forming machinery is set up into lines and manipulation between individual machines is performed by manipulators or robots - the forging line is controlled by computers (fig. 15.5).

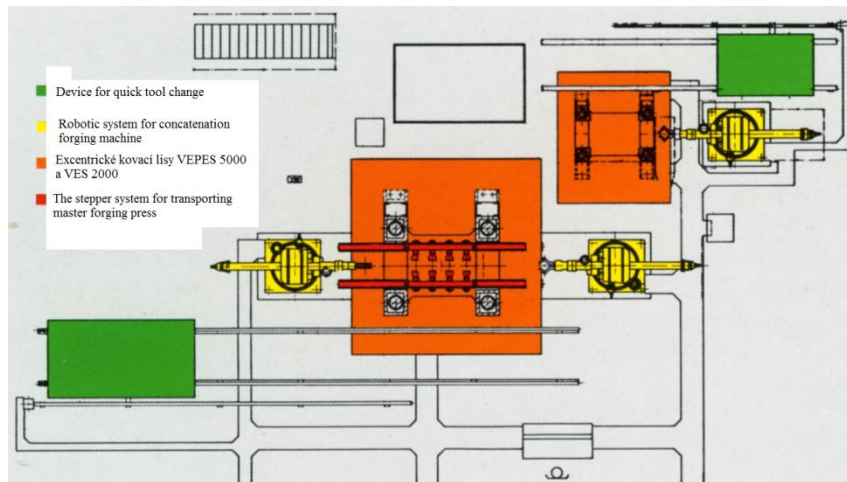

Fig. 15.5 Fully automatized forging line controlled by computer and services by robots

An example can be the Bofors - Kilsta forging line to produce diesel engine crankshafts, which is comprised of devices for induction heating with power of 2.5 t hod^{-1} , a hydraulic press for cutting at heat with cutting force of 2 MN, automatic forging rolls containing two robots, an eccentric press with pressing force of 160 MN, which forges shafts weighing 250 kg and 1 900 mm in length, a mechanical cutting press with the force of 12,5 MN serviced by a robot, a hydraulic twister with force of 2 MN services by a robot, a hydraulic straightening and calibrating press with force of 16 MN services by two robots, a cooling line with three-zone cooling tunnel 44 000mm in length overall.

In the Czech Republic, ŠKODA AUTO forge in Mladá Boleslav produces crankshafts for passenger cars on a forging line installed in 1997. It is equipped with a vertical forging press LZK 3500, a robot and a cutting press LDO 500. The material is micro-alloyed steel 38MnS6, weight of the product is about 13kg. The forging line is controlled by a central control system.

Another option is gradual forging. Fig.15.6 shows a schematic of the technological process of die forging a pivot.

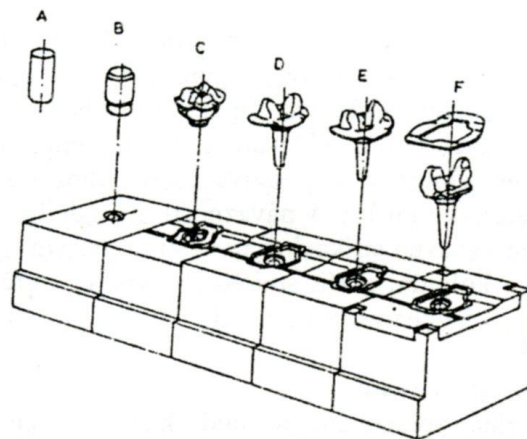

Fig. 15.6. Technological process of die forging a pivot.

15.7 Tools for hot forging

Tool steel is used for hot forging, which is resistant to wear at heat. The main producer of die steels in the Czech Republic was Poldi Kladno. After the company collapsed, this role was taken over by ŽDAS, which produces die steels 19 520, 19 642, 19 655, 19 662, 19 663, 19 665; supply from western companies such as the Swedish Uddeholm Tooling AB plays an important role here. Top steelworks test new materials for dies, such as German steelworks Edelstahl Witten – Krefeld GmbH - it developed a new steel for dies, designated DIN 45MoCrV5-3-1 with the target chemical composition of C 0,45%, Si 0,30%, Mn 0,30%, Cr 3,00%, Mo 5,00% and V 1%. This steel exhibits substantial improvement in resistance against heat wear, has increased creep resistance and better heat conductivity. Fig.15.7 shows the annealing diagram for this steel. It is common to welding the worn parts of dies. For example the Castolin Eutectic company supplies a device for plasma welding of dies. Thermal processing is performed in vacuum furnaces, quenching in current of gases, shaping is done in quenched state.

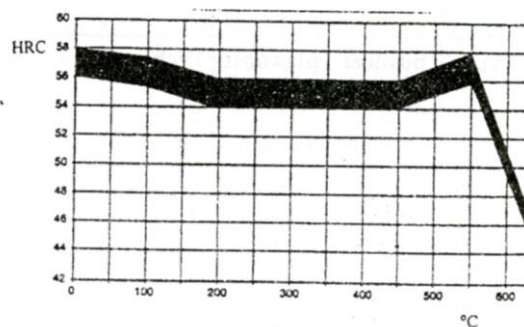

Fig. 15.7. Annealing diagram of tool steel DIN 45MoCrV 5-3-1

15.8 Forging simulation

With the increasing complexity of die forgings, requirements on perfect filling of their cavities are increasing. Currently, there are effective measures of computer support which allow for observing the flow of the material in a pre-designed die cavity (material flow simulation in a die); the aim is to achieve perfect filling of die cavities during forging and elimination of an defects. There is a number of systems, such as FORM-3D which is based on the finite elements method.

15.9 Manipulators and robots

The use of robots for manipulation with blanks and between the forming operation and between forming presses is economical primarily in forging of large series of die forgings such as in automotive industry (fig. 15.8).

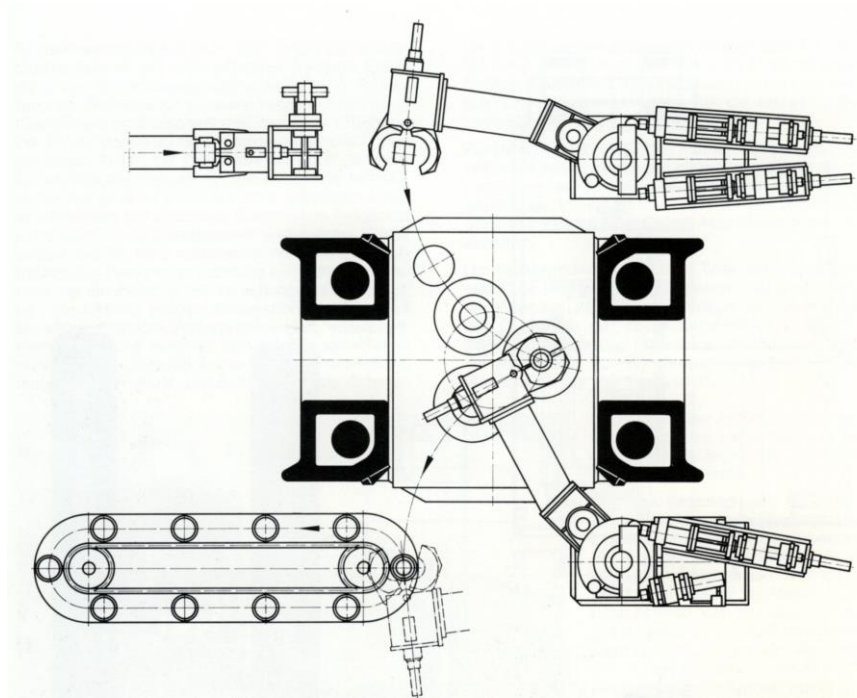

Fig. 15.8 Robotics of a forging press workstation

The basic parameters of the robots are the number of axes (degrees of freedom), repeatability of the set position, speed, weight of the burden, number of digital inputs, control modes and power. Another important piece of equipment of the robots is a thermometer - allows for sorting correctly and incorrectly heated blanks. Fig.9 schematically shows robots for hot forming by Lambertson Robotics and table 15.1. gives technical parameters of this company's robots.

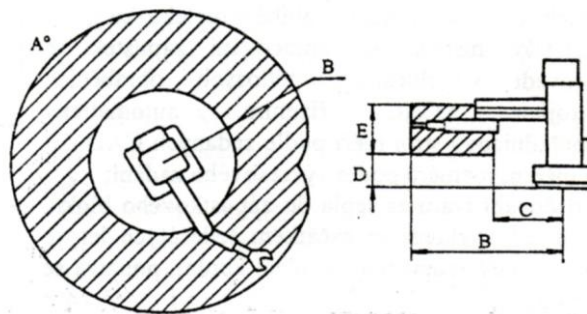

Fig. 15.9. Schematic show of range (crosshatched) of the AA 150 through 700 type robots for hot forming by Lambertson Robotics, ranges A,B,C,D,E are stated in tab.1.

Tab. 15.1. Parameters of hot forming robots of Lamberton Robotics, electrical or electro-hydraulic drive, degree of freedom 3 to 7.

Type	Capacity (kg)	Precision (± mm)	speed (m.sec ⁻¹)	A arc (°)	B max. radius (mm)	C min. Radius (mm)	D min. height (mm)	E Vertical movement (mm)
AA 150	200	0,50	6	300	3200	1500	700	1000 – 2000
AA 300	375	0,50	6	300	3200	1500	700	1000 – 2500
AA 700	850	0,75	2	360	3600	1800	1650	1200 – 2500
AA 1300	1500	3,50	1	360	3600	1800	1650	1200 - 2500

15.9 The use of die forgings in car industry

In car industry which is the biggest consumer of die forgings, the development leads to a decrease in car weight with the aim of lowering the fuel consumption. Currently, the car industry places these requirement on die forgings:

- use of steel with higher strength,
- increasing of hardness by using materials with higher elasticity module,
- decrease of production costs.

15.10 The technology of die production

The production of dies is done by traditional methods on machining equipment; the innovation started years ago; this primarily means electrical discharge machining (spark machining, spark erosion), which started its development 30 years ago. There are two methods of electrical discharge machining (EDM):

- EDM using a forming electrode made of copper or graphite; removal of material is done through electrical discharge; temperature of 8000-12000°C causes melting and evaporation of metal; CNC control system; the main advantage of EDM is chip-less technology; after programming, the process does not require constant servicing,
- EDM using wire-cutter; instead of a forming electrode, a thin wire with the radius of several tenths of a millimetre is used (the electrical erosive process occurs in dielectrics).
- classical mechanical machining of dies is performed in high-speed five-axis machines with CNC control; an automatic coordination machine measures the dimensions based on CAD data and blueprints,
- hot imprinting of shape into the die black was testes in early 60s in VÍTKOVICICE-CYLINDER (dies for grinding balls), its use is limited.

15.10 Lubrication

Lubricants are an important part of the die forging technology; the functions of die lubricants are:

- formation of a high-quality coating
- lowering friction

- resistance to temperature and abrasion
- easy withdrawal of the forging from the die

The most efficient lubricant for die forging is graphite in form of graphite suspensions. These suspensions are produced with different spectrum of particles based on the required machining conditions. A robot is used to apply the lubricant onto the forging cavity - its movements are programmed based on the lifts of the press. The robot is equipped with spray nozzles which spray the lubricant - colloid graphite mixed with water in certain ratio based on the machining process.

15.11 Thermal processing

Thermal processing is either traditional, i.e. the die forgings are annealed, ennobled, equalized or they are cooled after forging; these die forgings are produced from micro-alloyed steels. Fig. 15.10 shows individual operations and temperatures at forging and thermal processing of a die forging from common steel Ck45 and of a die forgings from micro-alloyed 49MnVS3 steel.

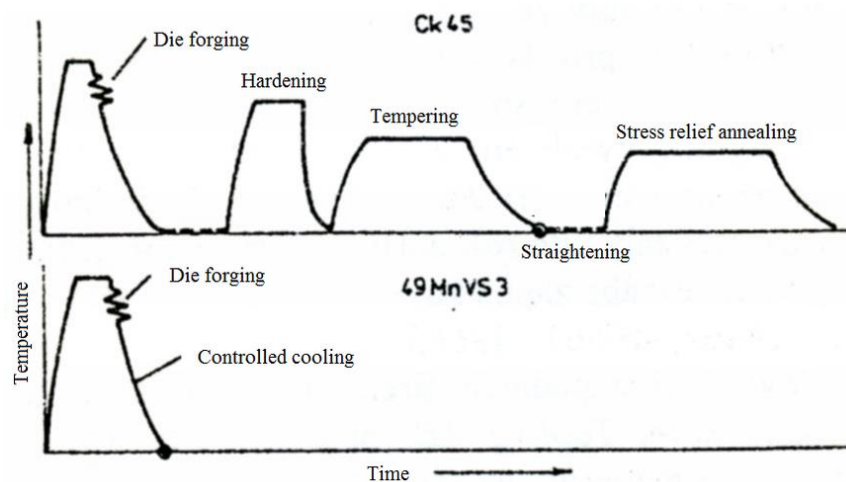

Fig. 15.10. Forging and thermal processing of die forgings from common Ck45 steel and from micro-alloyed 49MnVS 3 steel.

As quenching mediums, water is used as well as quenching oils - synthetic quenching oils based on polyethylene glycol, synthetic quenching oils based on esters and polymer quenching mix based on polyalkylene glycol; these oils and quenching mixtures are ecologically friendly. The machinery for thermal processing of die forgings is put into the forging lines.

15.11 Ecological problems in forging

Ecology – vasoneurosis, a common ailment of smiths is on the decline because currently, manipulation with material in die forging should be handled entirely by robotics. The main ecological problem then is noise, which causes another common illness of smiths and forgers - deafness. The decrease of noise is being worked on more or less successfully. Another problem are shocks.

15.12 Product quality

The requirements on quality of die forgings, especially connected with their use in top equipment, are always rising. Die forgings must meet geometrical dimensions in the required range tolerance, they cannot exhibit cracks, decarbonization or carbonization or the surface layers must meet the agreed standards which also goes for mechanical values and impact strength. The correct flow of fibres which is not as important as it used to be, due to the purity of steel, increases strength against dynamic strain. Currently a range of testing methods is used to examine dimensions and quality of die forgings. These include:

- automatic coordinate measuring machine for examining the dimensions of die forgings, prescribed geometry including the tolerances is input into the computer. The found values are registered and compared with the input values. The measuring machine is designed to measure all dimensions of the forging as accurately as possible,
- dynamic tests of die forgings on pulsators where the forging is tested with stress based on the standard operation conditions and number of cycles based on the overall lifetime of the machine in which it will be operating in. A pulsator installed in VŠB-TU Ostrava tested properties of springs for Vítkovice machinery.

15.13. Summary

The future of die forging lies in increasing of productivity, i.e. automatization and introduction of robotics into the machining process, increase of mechanical and plasticity properties of die forgings, precise forging of die forgings, i.e. achieving dimensions close to the machined part (development of die forging into enclosed dies), decrease of mechanical machining to a minimum, decrease of production costs and great attention will be paid on the ecological impact of the production (noise and shocks). Die forgings made from micro-alloyed steel will be put into the forefront as well as from steels with narrow guarantee of hardenability. Further development of die forging simulation will also be important.

Questions:

1. What does a collar represent?
2. What are the shapes of a separating plane?
3. How do you determine the additives for machining of rotary symmetric forgings?

Problems to solve:

1. Calculate the deformation force and deformation work at forging a rotary forging (radius 50 mm, $h_0 = 105$ mm, $h_1 = 40$ mm, $d_1 = 75$ mm. The intermediate product is made of Ck45 steel.
 2. Describe the basis of controlled forging and cooling of a 49MnVS3 micro-alloyed steel forging.
-