

Efforts to Improve Safety of Nuclear Power Plants

Masayoshi Matsuura
Kohei Hisamochi
Shinobu Ookido, Dr. Eng.
Koji Ando
Shingo Oda

OVERVIEW: Progress is being made on safety measures at Japan's nuclear power plants in preparation for their restarting operation, with new regulatory standards being implemented in July 2013 based on the lessons from the March 11, 2011 accident at the Fukushima Daiichi Nuclear Power Station of Tokyo Electric Power Co., Inc. Hitachi has been striving to improve the reliability, safety, and economics of nuclear power plants since its involvement in the construction of Japan's first BWR nearly 40 years ago, and has participated in the construction of more than 20 plants during that time. Drawing on this extensive experience and the lessons from the accident at the Fukushima Daiichi Nuclear Power Station, Hitachi is contributing to the operation and construction of safer and more reliable nuclear power plants by actively working toward the supply of plants with even higher levels of safety along with improvements to the safety of existing plants.

INTRODUCTION

THE great East Japan Earthquake in March 2011 and the accident at the Fukushima Daiichi Nuclear Power Station of Tokyo Electric Power Co., Inc. inflicted major damage on Japan. Taking the consequences of this accident to heart, Hitachi is fully involved in the recovery and rehabilitation of the affected regions and the Fukushima Daiichi plant, while also working to rebuild trust in nuclear power.

Hitachi has a track record of striving to improve the reliability, safety, and economics of boiling water reactors (BWRs), having participated in the construction of more than 20 such plants. In what can be seen as a culmination of this work, Hitachi's advanced BWR (ABWR) is the only generation III+ reactor (as defined by the U.S. Department of Energy) to have entered operation.

Progress is being made on safety measures at Japan's nuclear power plants in preparation for their restarting operation, with new regulatory standards being implemented in July 2013 that draw on the lessons from the Fukushima Daiichi Nuclear Power Station and include countermeasures against serious accidents, natural disasters, and man-made threats (terrorism). To enhance safety margins at existing plants in Japan, Hitachi has formulated and proposed optimal safety margin improvements that take account of the specific circumstances at these existing plants, and is participating in the design, manufacture, and installation of the associated equipment while also providing other assistance, including a variety of

analytical methods for the quantitative evaluation of these measures. Hitachi is also responsible for key equipment at ABWRs currently under construction and is assisting with further safety improvements to ensure compliance with the new standards.

This article describes the core strategies underpinning safety measures based on the lessons from the Fukushima Daiichi accident, and the implementation of safety measures associated with compliance with the new regulatory standards, and provides an overview of the specific safety equipment being deployed at existing Japanese nuclear power plants.

In general, the safety measures being deployed at existing Japanese plants will also be incorporated into plants constructed outside Japan. One such overseas project is the Visaginas Nuclear Power Plant Project in the Republic of Lithuania. Following on from the November 2012 completion of Hitachi's purchase of Horizon Nuclear Power Limited, a nuclear power development company in the UK, the entire Hitachi Group is also currently working together on the design of an ABWR with enhanced safety and on coordination with the regulatory authorities in the UK with the aim of constructing ABWRs in the UK.

CORE STRATEGIES UNDERPINNING SAFETY MEASURES

The following sections describe the thinking behind safety measures that draw on the lessons from the Fukushima Daiichi Nuclear Power Station, and the factors to be considered in their implementation.

Core Strategies

From the experience of the accident at Fukushima Daiichi Nuclear Power Station and the lessons learned, Hitachi has identified the following three core strategies for safety measures that take account of the potential for a large earthquake or tsunami to cause widespread damage at the site.

The first is to protect important safety equipment from loads caused by external events that do not exceed design assumptions. Examples include seawalls, watertight doors, and physically dispersed location of equipment for dealing with a loss of all alternating current (AC) power.

The second is to have portable equipment available that can respond flexibly (respond to external events that exceed design assumptions) if the safety equipment is compromised. It is also important to improve the robustness of the reactor containment vessel to prevent leaks of radioactive material.

The third is to put measures in place to ensure a coordinated on-site and off-site response to a major external disaster by preparing simple and practical measures that take account of the likelihood of damage across the entire site.

These concepts can also be applied to a defense-in-depth approach to ensuring plant safety. Table 1 gives an overview of the five layers of civil defense when the defense-in-depth approach is applied to safety at a nuclear facility.

The aforementioned first policy for ensuring safety amounts to adopting an approach of closely reviewing equipment designs to select appropriate assumptions for the loads imposed by an external event (layer 1), and to allow the layer 2 and 3 countermeasures to be implemented appropriately. Similarly, the second policy is related to the layer 4 response, whereby internal measures are put in place at the facility to deal with accidents that exceed the plant equipment

design assumptions set for layers 1 to 3. The third policy consists of measures that straddle the boundary between layers 4 and 5 by also making effective use of off-site resources.

In this way, the core strategies of the safety measures that draw on lessons from the accident at Fukushima Daiichi Nuclear Power Station strengthen each layer of the “defense-in-depth” approach, including the boundaries between layers.

Equipment Design Requirements

Safety equipment installed to cope with events in accordance with design standards achieves reliability both by taking a conservative approach to setting assumptions and through measures such as diversity and redundancy. A risk analysis of a plant fitted with this safety equipment can then be conducted to identify vulnerabilities and implement countermeasures (accident management measures). Through this process, it is possible to provide measures that will maintain effective functionality in the event of a simultaneous loss of safety equipment functions, for example. However, because a major external event that exceeds design assumptions by a significant margin is likely to also damage this pre-installed equipment, countermeasures in the form of the second type of policy are also required that are designed to provide a flexible response to a widespread loss of safety functions. That is, these are countermeasures that give operators more diverse and flexible options for how to respond. Examples of accident management measures are listed below.

- (1) Alternative control rod insertion method
- (2) Additional means of tripping recirculation pumps
- (3) Means of releasing reactor pressure under extreme circumstances
- (4) Reallocation of power supply from alternative power sources
- (5) Alternative water supply equipment
- (6) Primary containment vessel (PCV) vent
- (7) External access to means of releasing reactor pressure
- (8) Alternative water supply using portable equipment
- (9) Alternative PCV spray using portable equipment

Because the accident management measures are provided for the case when safety equipment designed to auto-initiate fails to operate, the core strategy is to provide diversity and flexibility through manual operation. However, considering the amount of time available, automatic operation has been selected for measures such as (1) to (3) that deal with events that unfold rapidly.

TABLE 1. Defense-in-depth Approach to Ensuring Plant Safety
In the case of a nuclear power facility, the three layers (preventing problems, preventing escalation, and minimizing impacts) are augmented by an additional two layers for dealing with severe accidents.

	Description
Layer 1	Prevent problems or faults from occurring
Layer 2	Prevent problems or faults from escalating into an accident
Layer 3	Minimize the impact of accidents
Layer 4	Internal countermeasures against accidents that exceed design assumptions
Layer 5	External countermeasures against accidents that exceed design assumptions

On the other hand, in the case of situations that last over a certain amount of time, such as measures for dealing with decay heat removal and a damaged core, because of the high degree of uncertainty in the accident sequence up to that point, and because attempting to deal sensibly with all possibilities may be unrealistic, it is important not to compromise accessibility and mobility of operation. This can be achieved by, for example, not requiring design conditions of enveloping nature regarding excessively comprehensive scenarios of failures and by not making conservative environmental assumptions. To this end, in the case of measures (6) to (9) and depending on the objective, it is appropriate to take account of practicality and ensure that actions can be taken quickly by providing equipment based on realistic rather than conservative assumptions.

Accordingly, it is desirable that design requirements make realistic assumptions that are based on the characteristics of the measure concerned.

CONSIDERATION OF NEW REGULATORY STANDARDS

The new standards were prepared with consideration of both major accidents and accidents within design assumptions. In the core strategies underpinning safety measures, meanwhile, the purpose of the first strategy is to minimize the impact of accidents that are within design assumptions, whereas the second and third strategies are intended to deal with major accidents. The facilities for dealing with major accidents referred to in the new standards include both fixed and portable equipment intended for this purpose and also for dealing with major accidents of a specific type. In addition to using the portable and other equipment referred to above, it is also possible to comply with all aspects of the standards by incorporating the concept of a backup building⁽¹⁾.

Of particular importance when considering these standards is to reduce overall risk by striking a balance in the equipment design between providing equipment for dealing with major accidents that focuses on plant vulnerabilities and preventing this additional equipment from having a negative impact on the equipment provided to deal with accidents within design assumptions. This demands a basic philosophy in which the priority placed on facilities for dealing with major accidents is raised to the minimum extent needed for the operation of equipment for dealing with major accidents, while still maintaining the priority of equipment for dealing with accidents within design

assumptions. For example, while isolation functions are important, because of the concern that overzealous use of isolation functions will significantly degrade access to portable equipment connection points and leave the equipment unusable in an actual accident, it is necessary to adopt an approach that includes prioritizing portable water supply over isolation functions, but only to the extent necessary. In adopting this approach, Hitachi needs to pay careful attention to future debate over new regulatory standards.

USE OF SAFETY EQUIPMENT

This section describes how safety equipment that is designed considering the core safety measure strategies and the new regulatory standards is used in practice. It divides safety equipment into four main categories and gives an overview of equipment that can be enhanced to provide additional safety measures. Note that not all listed equipment needs to be installed. Rather an appropriate selection is made based on the resilience of each plant.

(1) Equipment for dealing with accidents within design assumptions

To enhance equipment for dealing with accidents within design assumptions, Hitachi has identified specific equipment based on an assessment of the impact of events such as internal fires, internal spills, or external events (volcano, tornado, or external fires). The two main enhancements to equipment for dealing with accidents within design assumptions are as follows.

(a) Measures for dealing with internal fires

Provide equipment that can prevent safety being compromised by an internal fire.

(i) Use of non-flammable or fire-retardant materials

(ii) Install fire detection sensors

(iii) Install firefighting equipment

(iv) Use of firewalls to contain fires, and so on.

(b) Measures for dealing with internal spills

Provide equipment that can prevent safety being compromised by an internal spill.

(i) Install watertight doors

(ii) Install dams

(iii) Install leak detection sensors, and so on ...

(2) Equipment for dealing with major accidents (permanent equipment)

Permanent equipment is provided to ensure that its functions will be available for quick deployment, to prevent problems such as serious damage to the reactor core or rupture of the containment vessel, and also to inhibit release of radioactive material and minimize

its dispersion. The following are some examples of key equipment.

(a) Alternative low-pressure water supply

Install an alternative low-pressure water supply for responding to accidents within design assumptions that provides additional options for low-pressure water supply, and that can also help prevent damage to the reactor core by injecting water into the core in the event of an accident that exceeds design assumptions.

(b) Install filter vents

Install equipment for venting the containment vessel externally to remove heat and protect against overpressure. Because this results in the external release of gases from the containment vessel, install filter vents in the exhaust flow path to reduce the amount of released radioactivity by trapping the radioactive aerosols contained in the vented gas.

(c) Containment vessel sprayer

Install equipment for spraying coolant inside the containment vessel to prevent damage by cooling the containment vessel (removing heat). Because spraying coolant inside the containment vessel does not need to start immediately, it is possible to use portable water pumps for this purpose. In this case, provide two separate connection point locations outside the building to provide physical separation, and use permanently installed fittings to supply the containment vessel sprayers from these external connection points so as to reduce the work required by operators to use the system.

(d) Indoor passive autocatalytic recombiner (PAR)

Install a PAR in the reactor building to keep the concentration of hydrogen below the ignition point when there is the potential for hydrogen gas released into the containment vessel following damage to the core to have leaked into the reactor building. Utilize three-dimensional flow analysis to select an appropriate location for the PAR.

(e) Reactor well water supply

Install a water supply to irrigate the reactor well to remove heat from the containment vessel and prevent damage to heat-sensitive non-metallic components such as gaskets by cooling the upper part of the containment vessel. Because supplying water to the reactor well does not need to start immediately, use portable water pumps for this purpose. Also, provide two separate connection point locations outside the building to provide physical separation, and use permanently installed fittings between these external connection points and the reactor well so as to reduce the work required by operators to use the system.

(f) Water supply to the lower part of the containment vessel

To prevent rupture of the containment vessel when the core has suffered serious damage, install equipment for irrigating the lower part of the containment vessel to cool a melted core that has flowed to the bottom of the vessel. Because supplying water to the lower part of containment vessel does not need to start immediately, it is possible to use portable water pumps for this purpose. Also, provide two separate connection point locations outside the building to provide physical separation, and use permanently installed fittings between these external connection points and the lower part of containment vessel so as to reduce the work required by operators to use the system.

(g) Water supply and sprayers for spent fuel pool

To provide equipment for cooling the spent fuel pool that operates differently to the equipment provided for dealing with accidents within design assumptions, install a system for topping up the water in the spent fuel pool to ensure that the pool is kept cool and to prevent fuel damage. Because spent fuel pool cooling does not need to start immediately, it is possible to use portable water pumps for this purpose. In this case, provide two separate connection point locations outside the building to provide physical separation, and use permanently installed fittings between these external connection points and the spent fuel pool so as to reduce the work required by operators to set the system up for use. Also, to allow for situations in which the level of damage is difficult to predict, such as terrorist attacks, adopt a configuration that allows both water supply and spraying to operate simultaneously by installing sprayers in the spent fuel pool for discharging water so that water can be sprayed over the fuel.

(h) Alternative high-pressure water supply

The reactor core isolation cooling system (RCIC) is intended for dealing with accidents within design assumptions when the reactor core has been isolated. To provide an alternative to this system and prevent core damage, install an alternative high-pressure water supply so that water cooling can still be performed when the reactor is at a high pressure.

(i) Equipment for enhancing operation of main steam safety relief valves (SRVs)

Enhance the opening mechanisms of main steam SRVs to deal with events that exceed design assumptions by providing backups for the nitrogen gas cylinders used to operate the valves and raising

their operating pressure so that valve opening will work better, and by enhancing the power supplies required for valve opening. Work is also proceeding on the development of equipment that will allow main steam SRVs to be opened using nitrogen gas as the sole driving force without the need for an electric power supply.

(3) Equipment for dealing with major accidents (portable equipment)

Additionally to the permanent equipment, provide portable equipment for dealing with major accidents to prevent problems such as serious damage to the reactor core or rupture of the containment vessel, and also to inhibit release of radioactive material and minimize its dispersion. In using portable equipment, it is a prerequisite that the objective of the system (such as preventing core damage) should be able to be achieved even though the system will not be available for use until after the time required to set it up, including transportation and installation.

The following are two key examples of portable equipment for dealing with major accidents.

(a) Alternative auxiliary reactor cooling water system

The auxiliary reactor cooling water system is provided for dealing with accidents within design assumptions. As a backup to this system, provide an alternative auxiliary reactor cooling water system on a trailer that includes pumps, heat exchangers, and other equipment that can be used in place of the auxiliary reactor cooling system.

(b) Water tankers

Provide water tankers to transport water to the reservoirs used to supply equipment for dealing with major accidents, namely containment vessel sprayers, reactor well water supplies, and spent fuel pool water supplies and sprayers.

(4) Equipment for dealing with specific types of major accident

Install equipment that provides functions required to deal with major accidents or other events related to terrorist acts such as deliberately crashing a large aircraft into a reactor building.

In general, these are dealt with by providing a backup building that houses the reactor water supply equipment, containment vessel sprayers, equipment for reducing reactor pressure, spent fuel pool water supplies and sprayers, power supplies, and instrumentation.

The next section describes details of key permanent equipment for dealing with major accidents.

Filter Vents

A number of measures are planned to ensure the integrity of the containment vessel during a major accident even if the core is damaged, including maintaining the vessel's water supply and cooling, along with the power supplies they require. Filter vents are provided for the case when control of the containment vessel pressure becomes difficult despite these measures being implemented. Filter vents reduce radioactivity by filtering out radioactive aerosols contained in gases that pressure control has released from the containment vessel to reduce the pressure inside it.

Hitachi has adopted wet filter vent technology from AREVA SA and is working diligently to design, manufacture, and install filter vents for use in boiling water reactors in Japan.

Fig. 1 shows the structure of a filter vent. The filter vent combines two types of filters in an upright cylindrical housing made of stainless steel. The first filter stage consisting of venturi nozzles (scrubbers) traps relatively coarse aerosols contained in the gas released from the containment vessel. Further filtering of finer aerosols is then performed in the second filter stage (metal filters).

The following points were considered as a result of lessons learned from the accident at the Fukushima Daiichi Nuclear Power Station.

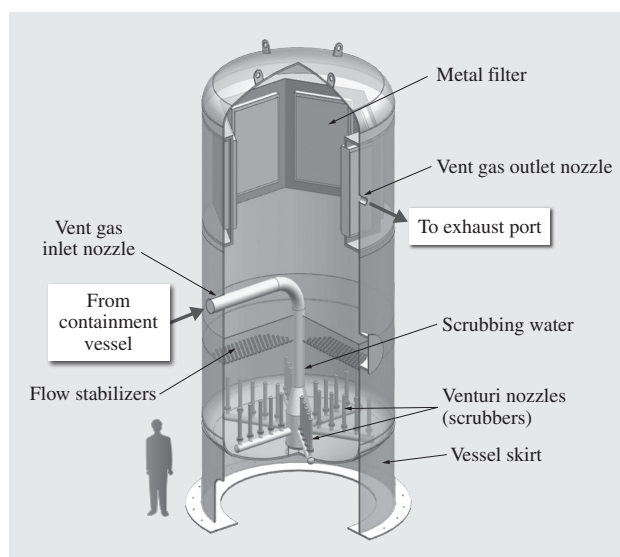

Fig. 1—Structure of Filter Vent.

A filter vent contains venturi nozzles (scrubbers) and metal filters, which together efficiently trap aerosols. The scrubber enhances the adsorption of aerosols by forming a gas-liquid mixture by circumferentially injecting tiny droplets of scrubbing water into the fast-moving gas in the venturi nozzle.

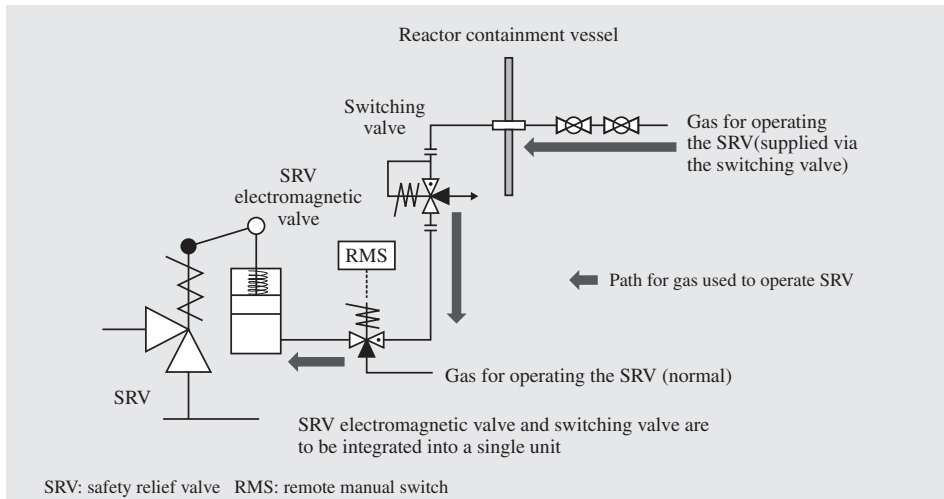

Fig. 2—Example System Configuration of Pressure Relief Mechanism for Reactor Pressure Vessels that Uses Switching Valve.

The SRV can be forcibly opened without an electric power supply by supplying gas for operating the SRV to the drive supply line connected to the switching valve in order to pressurize the SRV cylinder via the switching valve and SRV electromagnetic valve.

(1) Improvements to operation

To ensure that the filter vents will still be able to operate even if all AC power has been lost, valves driven pneumatically or by direct current (DC) are used for the isolation valves, and the valves are able to be operated manually in place through a shielding wall. To allow for monitoring, passive devices are used for the instrumentation around the filter vents required for plant operation.

(2) Preventing hydrogen explosions

The interior of the filter vents is filled with nitrogen to ensure that any hydrogen that gets in during venting does not ignite.

Functional Enhancements for Main Steam SRVs

If a major accident or other event results in all power being lost, including DC power supplies, electromagnetic valves used to operate relief valves to directly relieve pressure in the primary reactor system will not be able to be used. This makes it difficult to reduce the pressure in the primary reactor system, a prerequisite for supplying large quantities of coolant to the core. As having portable DC power supplies or other backup power supplies available for this key equipment is an effective way of dealing with the problem directly, it is being installed or planned. Meanwhile, to provide another way of dealing with situations like this, Hitachi has developed a switching valve mechanism that can operate without a power supply and act as a relief valve for the main steam SRVs used to reduce pressure in the primary reactor system.

These switching valves have two outlets that share a common inlet. They work by using the force of the

inlet pressure to automatically close the common inlet or one of the outlets. Specifically, the normally open outlet of a switching valve is connected to outlet-side of the SRV electromagnetic valve and the other outlet is left open to the atmosphere so that gas for operating the SRV can be supplied to the common inlet. By using this switching valve to supply the gas that operates the SRV, this design provides a way for the SRV to function even when its electromagnetic valve cannot be energized due to loss of all power, including DC power. Fig. 2 shows the system configuration of a pressure relief mechanism for reactor pressure vessels that uses this switching valve. In addition to SRVs, the switching valve can also be used as a way of forcibly opening pneumatic valves that have failed.

Enhancements for High-pressure Water Supply

RCIC systems have conventionally been used to supply high-pressure water during a station black out (SBO) in which all AC power is lost. RCIC systems avoid the need for AC power by using steam from the reactor to run turbine-driven pumps.

As with RCIC systems, alternative high-pressure water supply systems that use turbine-water-lubricated (TWL) turbine-pumps also use turbine-driven pumps and are added as backups to the RCIC system (see Fig. 3). Hitachi is collaborating with its partner, GE Hitachi Nuclear Energy, on studying and proposing an optimum configuration for a system for dealing with severe accidents that takes account of the lessons from the accident at the Fukushima Daiichi Nuclear Power Station.

A feature of TWL turbine-pumps is that the turbine and pump are both integrated into the same housing, making them smaller than previous RCIC turbine-

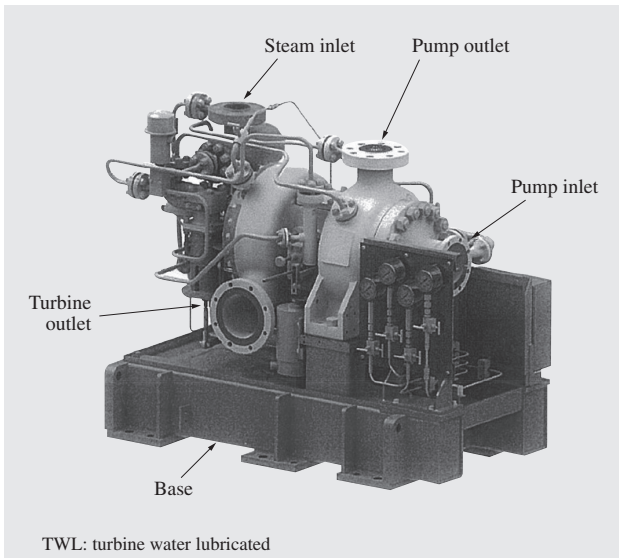

Fig. 3—TWL Turbine-Pump.

The TWL turbine-pump is contained in an integrated housing. Use of water-lubricated bearings and mechanical seals eliminates the need for a lubricating oil system and gland seal unit.

pumps. They are also made more compact by not requiring a gland seal unit (condenser, vacuum tank, and vacuum pump) which is due to use of mechanical seals in the turbine gland (see Fig. 4). Use of water-lubricated bearings also eliminates the need for a lubricating oil system, making it easier to find space for their installation.

The flow rate and pump head under high-pressure conditions are similar to or better than those of RCIC pumps. The pump also reduces control power consumption because it uses an internal mechanical mechanism to adjust the discharge flow rate of the pump and does not have an electrical control system.

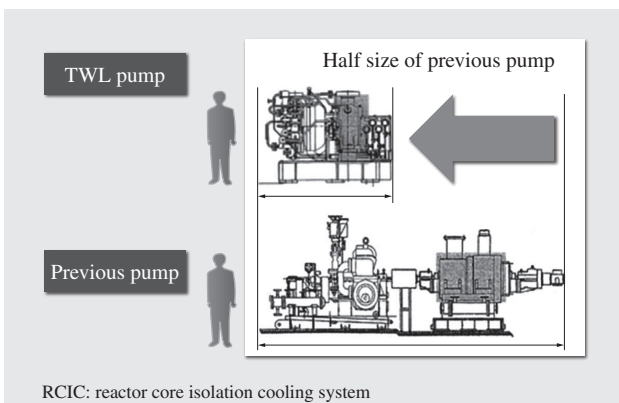

Fig. 4—Relative Sizes of TWL and Previous RCIC Pumps. TWL turbine-pumps are smaller than the RCIC pumps used in the past, making it easier to find space for their installation.

TWL turbine-pumps have been selected for use as RCIC pumps at the Lungmen Nuclear Power Plant in Taiwan, and Hitachi plans to use them as RCIC pumps at future overseas ABWR plants.

CONCLUSIONS

This article has described compliance with the new regulatory standards and the core strategies underpinning safety measures based on the lessons from the Fukushima Daiichi accident, and has given an overview of the specific safety equipment being deployed at existing Japanese nuclear power plants.

Hitachi believes that nuclear power plants represent an important part of a reliable energy mix that will strengthen Japan's energy security. It intends to draw on the lessons learned from the accident at the Fukushima Daiichi Nuclear Power Station to supply nuclear power plants with even higher levels of safety. Furthermore, the technologies described here will support the safe restarting of existing plants and contribute to the operation and construction of plants that are safer and more trusted.

REFERENCES

- (1) M. Matsuura et al., "Lessons Learned from Fukushima Daiichi Nuclear Power Station Accident and Consequent Safety Improvements," *Hitachi Review* **62**, pp. 75 – 80 (Feb. 2013).
- (2) "What Went Wrong and What Should be Done?," Report on Seminar on Accident at Fukushima Daiichi Nuclear Power Station, Nuclear Safety Subcommittee, Atomic Energy Society of Japan (Mar. 2013) in Japanese.

ABOUT THE AUTHORS



Masayoshi Matsuura

Nuclear Plant Engineering Department, Hitachi Works, Hitachi-GE Nuclear Energy, Ltd. He is currently engaged in the design of enhanced safety systems and management of the next-generation reactor development project. Mr. Matsuura is a member of The Atomic Energy Society of Japan (AESJ).



Kohei Hisamochi

Nuclear Plant Engineering Department, Nuclear Reactor Engineering Section, Hitachi Works, Hitachi-GE Nuclear Energy, Ltd. He is currently engaged in the design of nuclear power plant safety. Mr. Hisamochi is a member of the AESJ.



Shinobu Ookido, Dr. Eng.

Nuclear Power Service Business Department, Hitachi Works, Hitachi-GE Nuclear Energy, Ltd. He is currently engaged in the project managements related to safety enhancement of nuclear power plant. Dr. Ookido is a member of The Society of Materials Science, Japan (JSMS), Japan Society Corrosion Engineering (JCORR) and The Japanese Society for Non-Destructive Inspection (JSNDI).



Ando Koji

Nuclear Plant Engineering Department, Nuclear Reactor Engineering Section, Hitachi Works, Hitachi-GE Nuclear Energy, Ltd. He is currently engaged in the design of nuclear power plant systems.



Shingo Oda

Nuclear Plant Engineering Department, Nuclear Reactor Engineering Section, Hitachi Works, Hitachi-GE Nuclear Energy, Ltd. He is currently engaged in the design of nuclear power plant safety. Mr. Oda is a member of the AESJ.