

The Russian Northern Fleet

Sources of Radioactive contamination

Thomas Nilsen
Igor Kudrik
Alexandr Nikitin

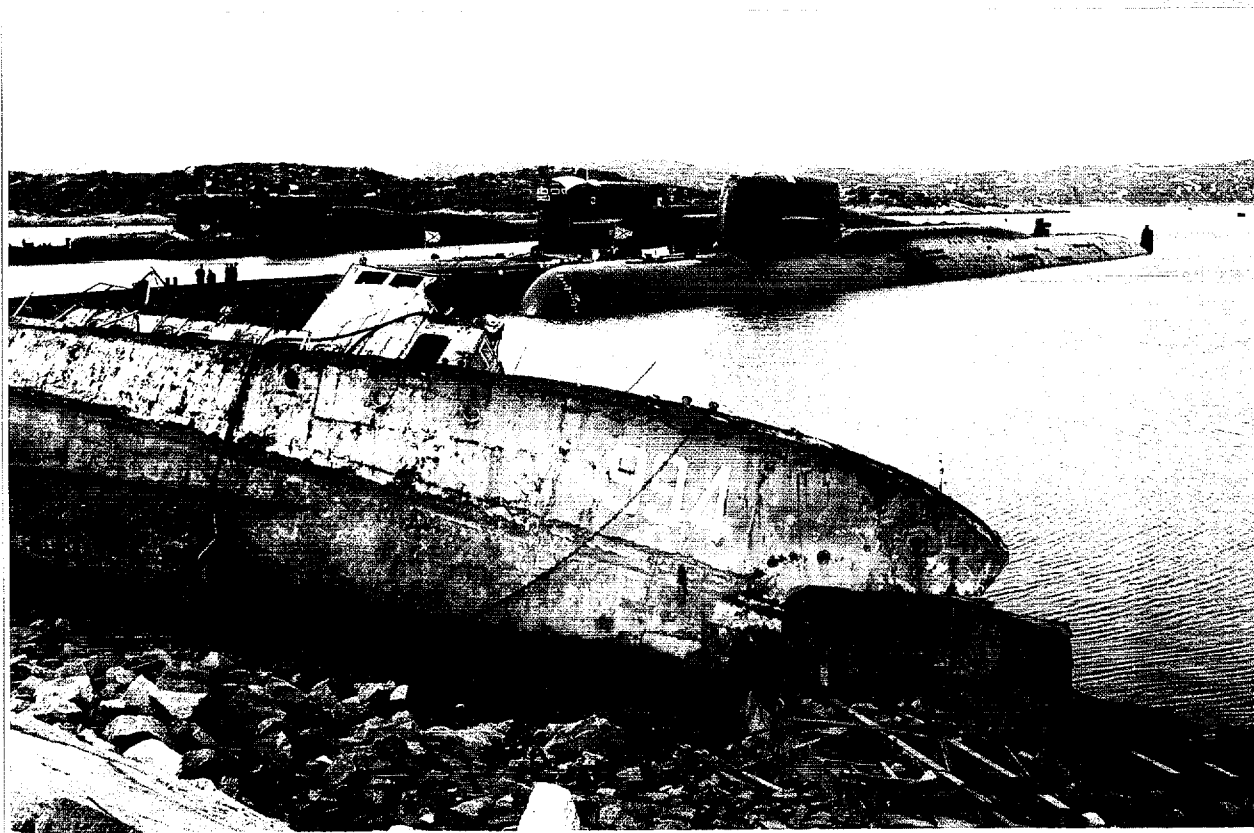



NO9600025

Bellona Report Volume 2:1996

The Russian Northern Fleet

Sources of Radioactive contamination

Thomas Nilsen
Igor Kudrik
Alexandr Nikitin

The publication of this report is sponsored by:
Stiftelsen Fritt Ord/Foundation for Freedom of Expression
(Main contributor)

Contributors:

Norsk Hydro a.s. Petrochemicals Division Aker ASA Chemical Workers Union of Norway Norwegian Seafood Export Council FESIL AS Norwegian Society of Engineers Confederation of Norwegian Business and Industry WASA Försäkring (Stockholm) Norwegian Fishermen's Association Norwegian Federation of Oilworkers' Trade Union Norwegian Polar Institute Odda Smelteverk	NORSAS, Norwegian Resource Centre for Waste Management and Recycling Norsk Sivilingeniørers Forening Norges ingeniørorganisasjon (NITO) Green Sea Operations AS UNI STOREBRAND AGA AS OZO Hotwater A/S Energiforsyningens Fellesorganisasjon EnFO Store Norske Spitsbergen Kullkompani AS Svalbard Samfunnsdrift AS Norzink AS
---	---

Published by:
The Bellona Foundation

Norway:

P.O. Box 2141, Grünerløkka
N-0505 OSLO, Norway.
E-mail: bellona@sn.no

Russia:

Russia
183038 Murmansk
P.O. Box 4310
Bellona Russia
E-mail: bellona@sn.no

Brussels:

Bellona Europa
142-144 Avenue de Tervueren
B-1150 Bruxelles
Belgium
E-mail: bill.law@eppa.com

USA

Bellona USA
310 D Street NE
Washington, DC 20002
USA
E-mail: kvanderh@icta.org

URL:

<http://www.grida.no/ngo/bellona/>

ISBN 82-993138-5-6

ISSN 0806-3451

Lay-out: K R Nygaard, Bellona.

Printing: a.s. Joh. Nordahls Trykkeri

Photos:

John Berg (archive), Thorbjørn Bjørkli, Per Ståle Bugjerde, Nils Bøhmer, The Norwegian Defence, Frederic Hauge, Aleksej Klimov, Igor Kudrik, Thomas Nilsen, The Northern Fleet Museum (archive), NTB, NUPI, Andrej Pronin, Scanfoto.

Copying permitted when source is stated.

Comments to this report are welcomed.

This report is available in English, Russian and Norwegian.

Keywords: Kola Peninsula, the Russian Northern Fleet, radioactive waste, radioactive contamination, nuclear submarines, nuclear accidents

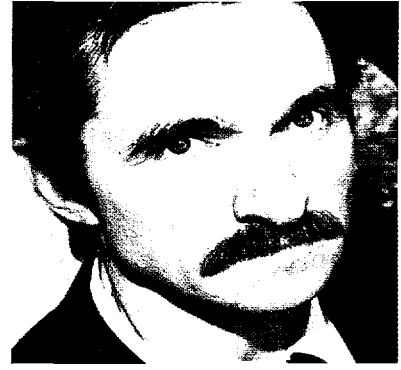

Authors

Thomas Nilsen (1968) is a member of the Bellona Foundation's Russian Studies group. Over the past eight years he has made extensive visits to Russia to study the environmental situation there. He is co-author of the report *Sources of Radioactive Contamination in Murmansk and Arkhangelsk Counties* and the working paper *Reprocessing Plants in Siberia*. He attended the Norwegian University of Technology and Natural Sciences and has a background in environmental journalism.

Igor Kudrik (1974) heads the Bellona Foundation's branch office in Murmansk. He has worked with several Russian environmental organizations and has spent the last two years establishing Bellona's Murmansk office. He attended the Murmansk School of Pedagogy. He specialises in the study of radioactive contamination emanating from both military and civilian sources.

Alexandr Nikitin (1953) has been a Bellona associate since 1994 and joined the Foundation's staff in 1995. He holds the rank of full captain and is retired from service. He was trained at the Naval College in Sevastopol and served with the Russian Northern Fleet until 1985. From 1985 until 1992, he worked at the Department of Nuclear Safety in the Ministry of Defence.

Advisory Panel

Nils Bøhmer (1967) joined the Bellona Foundation in 1993 and works as a nuclear physicist in the Russian Studies group. He is co-author of the report *Sources of Radioactive Contamination in Murmansk and Arkhangelsk Counties* and of the working paper *Reprocessing Plants in Siberia*. He holds a degree from the University of Oslo and was formerly with the Norwegian Radiation Protection Authority under whose auspices he attended an expedition to the sunken nuclear submarine Komsomolets in 1992.

Nikolai Mormul (1933) is a retired rear admiral of the Russian Northern Fleet. Trained at Dzerzhinsky Military Academy, he served aboard the first Soviet nuclear submarine K-3. He later served on board several other nuclear submarines, a number of which experienced nuclear incidents. From 1978 to 1983, he was chief of the Northern Fleet Technical Department. He is co-author of the book *The Nuclear Submarine Epoch*, and is also a member of the United Nations Academy of Information.

Vyacheslav Perovsky has served in one of the Northern Fleet's technical divisions and is a trained nuclear chemist. He assisted in the cleanup efforts following the 1982 accident at a nuclear waste repository at Andreeva Bay and has contributed to the construction of the present storage facility. He has been with the Minatom Institute for Industrial Technology (VNIPIET) in St. Petersburg since the mid 1980s.

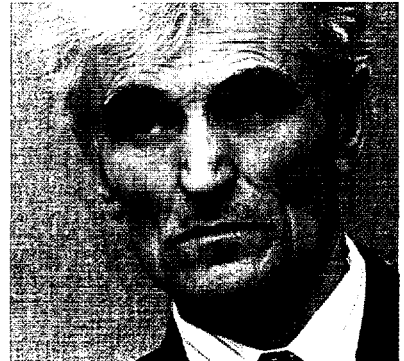

Can this information be kept secret?

The Bellona Foundation has been involved in environmental questions concerning north-western Russia and the Arctic since 1989. In our work we have surveyed the environmental challenges that exist in this region. We have particularly focused on environmental challenges represented by pollution from the petroleum industry, other industrial activities and nuclear facilities. With this report *The Russian Northern Fleet - Sources of Radioactive Contamination* we have compiled knowledge and statistics available from open sources. By presenting this information we hope to contribute to increased insight and consequently to help realise necessary national and international measures.

The report gives a comprehensive view of the serious situation which now exists in the Northern Fleet. In fact, 18 % of the nuclear reactors existing in the World are situated in this area. The Northern Fleet has a total of 270 reactors in service or in storage. Waste from an additional 90 reactor cores are stored under unsafe conditions at Zapadnaya Litsa. Eighteen reactor cores are stored under similar conditions on board storage ships and barges. The report further describes a series of circumstances which represent dangers to human health and the environment. The situation is grave and will require comprehensive measures to bring safety levels up.

A prerequisite for international co-operation is openness. This report offers a factual basis to assist in the development of proper risk assessment, problem solving and prioritising. It is our view that such work is best carried out through international co-operation, with particular emphasis placed on a strengthening of Russian treatment technology for nuclear fuel and wastes.

We have encountered some resistance in the writing of this report. The Russian Federal Security Police (FSB) has in various ways tried to hinder its completion and to criminalise its contents. One of the authors, Bellona employee Alexandr Nikitin, is now in custody under threat of the death sentence. He is accused of acts of high treason, and it is alleged that he has sold Bellona top secret information. Parts of the background material for this report was confiscated by Russian security police during a raid on Bellona's Murmansk office. Both of these events have hindered the completion of the report. Bellona has only an ecological

interest in publishing the report, which only concerns matters related to nuclear safety. Considerable effort has been made to provide comprehensive references making it clear that our sources of information have been open ones.

The report documents that without international co-operation and financing, a grave situation could arise which can be pictured as a Chernobyl in slow motion. If safety measures are not implemented, major accidents and the release of fissile material will be unavoidable. Keeping information of this nature secret constitutes a violation of the Law on State Secrets (1993) Article 7 which establishes that: "Information on the condition of the environment is not subject to classification". It further violates Article 10 of the Law on Information and Protection of Information (1995) which states: "It is prohibited to ascribe the following to materials with limited access:.. documents which contain information on extraordinary situations, environmental information and other information necessary to ensure the safe functioning of residential areas and industrial sites".

Nikitin's incarcerators are guilty of attempting to prevent information of a vital nature from becoming available to the population and official agencies. By classifying previously unclassified material and by preventing new information from emerging, the FSB threatens human health and ecological safety, both in Russia as well as in neighbouring states. For this they must be brought to account.

Nikitin must be released immediately. His imprisonment and the accusations against him are not only flagrant breaches of human rights and the rights of free speech, but also constitutes a direct hindrance to international involvement in the region. If Aleksandr Nikitin is sentenced for his participation in the work on this report, then what you now hold in your hand is an official state secret. If such is to be the case the foundation for international co-operation is non-existent, since that depends on at least the minimum of information which this report represents. New serious accidents will certainly occur if information of the type included in this report is to be considered classified.

Russia and other states must now increase the availability of information regarding military nuclear waste. Permission must be given for national and international bodies to inspect nuclear waste from military sources.

Frederic Hauge
managing director.

Preface

At the time that this report went to press, co-author Alexander Nikitin was being imprisoned because of the information that is presented here. Alexander Nikitin was arrested on February 6, 1996, by the Russian security police, FSB. He is accused of espionage and high treason against Russia for having sold top secret information to Bellona. This report shows that these charges are both false and unfounded. The information presented here has been gathered from open sources in Russia and in other countries over a number of years. The FSB campaign against Bellona is an attempt to halt the openness about environmental problems in Russia.

On October 5, 1995, FSB agents ransacked Bellona's office in Murmansk as well as the homes of several of our contact people at various locations in Russia. All of the background material we had gathered on the Russian Fleet was confiscated. None of this material has been returned, for FSB does not want international attention turned towards the threats to the environment posed by the nuclear installations of the Northern Fleet. Bellona would emphasise that free speech is the right of all democratic countries, including Russia. Openness on environmental matters is a right protected by the Russian constitution. Indeed, it is stated here that any public person attempting to conceal information about the environment shall be punished.

There is a large and justified concern over the releases of radioactivity from the Northern Fleet's many nuclear submarines and storage facilities for nuclear waste. These problems are not solved by attempting to intimidate the authors of this report, or other environmentally concerned individuals, into silence. The solution to these problems lies in a continued openness that can form the basis for a broad national and international co-operation. Therefore, the entire world has protested against the arrest of Alexander Nikitin and the FSB campaign against Bellona.

The Bellona Foundation has been working on environmental problems in northern Russia since 1989, and we recently issued the report Sources of Radioactive Contamination in Murmansk and Arkhangelsk Counties. Through our office in Murmansk, we have worked to establish contact between Russian and Western researchers and corporations. Bellona still maintains that international co-operation is important. The present report on The Russian Northern Fleet which we present here, offers a comprehensive basis

on which to determine the magnitude of the problems. A lack of technical information prevents us from making any conclusive risk assessment. The solution to the nuclear-related problems in the Arctic region lies in a broad co-operation between the countries who initiated the arms race of the cold war. In the case of Russia, this solution will depend upon further political and economic developments.

The sources we have used in this report include newspapers, professional literature, research reports and public documents. We have also had a number of meetings and participated in several conferences related to the dangers of radioactive contamination emanating from the nuclear installations of the Northern Fleet. During the preparation of this report, we have taken great pains to give references for all information cited here. Accurate information contributes to a clear and result-oriented discussion. Rumours and inaccurate information cause unnecessary fear and anxieties. Therefore Bellona considers it important that also the authorities present a better overview of possible sources of radioactive contamination within the Russian Northern Fleet and other nuclear facilities. This is true not only of Russia, but also of other countries who in the post war period have withheld vital information about the dangers of radioactive contamination to public health or the environment.

We would like to thank the many people who contributed to putting together this report. First and foremost, we have benefited greatly from the counsel of our advisory group, including Nils Bøhmer, Nikolai Mormul and Vyacheslav Perovsky. Frederic Hauge, Siri Engesæth, and Knut Erik Nilsen at The Bellona Foundation have assisted in collecting and working through the material. The report developed both in Norwegian and Russian in parallel, and has also been translated into English. Our colleagues Håkon Strand, Angelika Bækken and Luba Kovalova have made a tremendous effort in translating and interpreting. Jennifer Høibråten, Christian Rostock, Audun Sandvold, John Kenneth Stigum and Bjørn Hellem have translated the report into English. Sigurd Enge, Christian Rekkedal, Simen Graff Jensen, Karl Rikard Nygaard, Runar Forseth and Per Storm-Mathisen have assisted in the processing of the material. This has made it possible to post this multilingual report on Internet (<http://www.grida.no/ngo/bellona/>) where it can be periodically updated.

Table of Contents

Preface	8	Project 667 BDRM (Delfin) - Delta IV Class ..	52
Introduction	8	Project 670 A (Skat) - Charlie-I Class	53
CHAPTER 1			
The Northern Fleet	11	Project 670 M (Skat M) - Charlie-II Class	54
1.1. History	12	Project 671, 671 V, 671 K (Yersy) - Victor-I Class	55
1.2. Organisation and responsibilities	13	Project 671 RT Victor-II Class	56
1.3. The Northern Fleet today	13	Project 671 RTM (Shuka) - Victor-III Class ...	58
1.3.1. Economic conditions	15	Project 941 (Akula) - Typhoon Class	59
1.3.2. Reduced levels of competence in submarine crews	17	Project 949 (Granit) - Oscar-II Class	62
1.4. The future of the Northern Fleet	18	Project 949 A (Antey) - Oscar-II Class	62
CHAPTER 2			
Nuclear-powered vessels	23	Project 945, 945 A, 945 B (Mars) - Sierra Class	63
2.1. Construction of nuclear powered submarines		Project 971 (Shuka-B) - Akula Class	64
and surface ships	24	Project 885 - Severodvinsk Class	66
2.1.1. Design Bureau's	24	Project 645 ZhMT	67
2.1.2. Shipyards	25	Project 705, 705 K (Lira) - Alfa Class	68
2.2. Technological development of nuclear		Project 661 (Anchar) - Papa Class	70
powered vessels	25	Project 685 (Plavnik) - Mike Class	71
2.2.1. First generation nuclear submarines	25	Project 1851 - X-ray	72
2.2.2. Second generation nuclear submarines	25	Project 1910 - Uniform	72
2.2.3. Third generation nuclear submarines	26	Project 10831	72
2.2.4. The fourth generation of nuclear-powered submarines	27	Project 1144 (Orlan) - Kirov	73
2.2.5. Nuclear powered submarines with liquid metal		Project 1941 (Titan) - Kapusa Class	74
cooled reactors.	27	CHAPTER 3	
2.2.6. Prototype submarines	27	Service ships and special tankers	75
2.2.7. Mini submarines	28	3.1. Service ships for liquid radioactive waste	76
2.2.8. Nuclear-powered surface vessels	28	Project 1783 A - Vala class	77
2.3. Development of naval reactors	29	Project 11510 - Belyanka class	79
2.3.1. First generation reactors	30	3.2. Service ships for spent nuclear fuel	80
2.3.2. Second generation reactors	32	Project 2020 - Malina class	81
2.3.3. Third generation reactors	33	Project 326 - 326 M	83
2.3.4. Fourth generation reactors	34	Severka	84
2.3.5. Liquid metal cooled reactors	24	CHAPTER 4	
2.3.6. Nuclear reactors on surface vessels	35	Radioactive waste at the naval bases	85
2.3.7. Russian submarine fuel	35	4.1. The development of naval bases	86
2.4. Radiation risks in naval reactors	37	4.2. Generation of radioactive waste and spent	
2.4.1. Radiation safety agencies for nuclear-powered		nuclear fuel	87
submarines	38	4.2.1. Risk Assessments	88
2.5. Classification of nuclear powered naval vessels	39	4.3. Zapadnaya Litsa	89
Project 627, 627 A (Kit) - November class ...	40	4.3.1. Malaya Lopatka	90
Project 658, 658 M - Hotel Class	42	4.3.2. Bolshaya Lopatka	91
Project 659, 659 T - Echo-I Class	44	4.3.3. Nerpichya	92
Project 675, 675 M, 675 MKV - Echo-II Class	45	4.4. Vidyayev	103
Project 667 A (Nalim, Navaga) - Yankee Class	46	4.5. Sayda Bay	103
Project 667 B (Murena) - Delta-I Class	49	4.6. Gadzhievo	105
Project 667 BD (Murena M) - Delta-II	50	4.7. Severomorsk	105
Project 667 BDR (Kalmar) - Delta-III Class ..	51	4.8. Gremikha	106
		4.8.1. Storage of solid radioactive waste	107
		4.8.2. Storage of liquid radioactive waste	107

4.8.3. Storage of spent nuclear fuel assemblies	88
---	----

CHAPTER 5

Naval yards	111
5.1. Economy and organisation	112
5.2. Navy yard no. 10 - Shkval	113
5.2.1 1 Storage of radioactive waste	114
5.3. Navy yard no. 82 - Safonovo	114
5.4. Naval yard No. 35 - Sevmorput	115
5.4.1 Storage of radioactive waste	115
5.5. Naval yard No. 85 - Nerpa	116
5.6. The Severodvinsk Naval yards	118
5.6.1 Storage of solid radioactive waste.	119
5.6.2 Treatment of liquid radioactive waste	122
5.6.3 Release of radioactive gases from Zvezdochka	123
5.6.4 Storage of reactor compartments and spent nuclear fuel	123

CHAPTER 6

Decommissioning of nuclear submarines	125
6.1. Laid up nuclear submarines	126
6.2. Safe storage of nuclear submarines	129
6.3. Dismantling of submarines	130
6.3.1. Economic aspects	130
6.4. Parties to the work of dismantling submarines	132
6.5. Stages in decommissioning	133
6.5.1. Preparation of the reactor compartments	134
6.5.2. Dismantling submarines with damaged reactors	135
6.5.3. Transportation of reactor compartments	136
6.5.4. Plans for long term storage of reactor compartments.	136
6.6. Radio ecological problems of dismantling	138

CHAPTER 7

Handling of spent fuel assemblies	141
7.1. Organisation and responsibility	142
7.2. Russian submarine fuel	143
7.3. Transport containers	145
7.4. Transport routes	146
7.5. Financial aspects	147

CHAPTER 8

Nuclear submarine accidents	149
8.1. Sunken nuclear submarines	150
8.1.1. K-8	150
8.1.2. K-219	151
8.1.3. K-278 (Komsomolets)	151
8.2. Reactor accidents	152
8.2.1. Nuclear accidents	152
8.3. Fires resulting in loss of life	155
8.4. Causes of accident	156

Appendix	159
1. USA	160
1.1. Attack submarines, SSN	160
1.2. Ballistic missile submarines, SSBN	161
1.3. Accidents	161
2. United Kingdom	162
2.1. Attack submarines	162
2.2. Ballistic missile submarines	162
3. France	163
4. China	163
5. India	163

References	164
Suggested reading	167

Introduction

In 1996 the Russian Navy celebrates its 300th anniversary. Nuclear submarines have been in service with the Northern Fleet for nearly 40 years. This report describes the problems that the Russian Northern Fleet is experiencing with its nuclear powered vessels and with the storage of spent nuclear fuel and other radioactive waste that the operation of these vessels generates. The Kola peninsula and Severodvinsk have the highest concentration of nuclear reactors, active and derelict, in the world. The cold war arms race went too fast for authorities to plan what to do with decommissioned submarines and the nuclear waste. The present generation must now handle the clean-up efforts. This report describes the challenges that we face.

Chapter 1 gives a historic summary of the Northern Fleet, from 1899 until the collapse of the Soviet empire in 1991. Efforts have been devoted to showing the effects of the social, political and economic situation in the former Soviet Union/Russia on the Northern Fleet over the past five years. The last part of the chapter covers the command structure and areas of responsibility within the Russian Navy and in other institutions related to the running of nuclear powered vessels.

Chapter 2 describes the different types of submarines which are, or have been, in operation with the Northern Fleet. Much attention is given to the development of submarine classes and reactor design, as this is crucial to understanding the inherent dangers and the costs, both of operating and decommissioning the various types of vessels as well as the amount of nuclear waste that is generated by running them.

Chapter 3 covers the special service ships and tenders in service with the Northern Fleet. These vessels are used for refuelling the nuclear submarines. There is an extensive transport of nuclear fuel and waste around the Kola peninsula and in the Severodvinsk area. Most of the service ships are in poor technical condition.

Chapter 4 gives a geographical survey of the naval bases that serve nuclear submarines and nuclear powered surface vessels. These bases are situated from Zapadnaya Litsa in the west to Gremikha in the east. The naval bases also contain the Northern Fleet's largest temporary storage facilities for spent nuclear fuel and other nuclear waste. All of the listed repositories are full. Their poor technical condition highlights the need for rapid measures.

Chapter 5 gives a description of naval shipyards in Severodvinsk and on the Kola Peninsula. Some yards do not fall under Northern Fleet command, but are included because they play a part in the maintenance of the active

nuclear submarines or in the decommissioning of inactive submarines.

Chapter 6 outlines the process of decommissioning nuclear submarines. Emphasis is placed on the problems associated with the storage of submarines which have not yet been defuelled. An official Russian programme for the decommission of nuclear submarines has been developed, and the difficulties encountered by the shipyards entrusted with this work is described. Plans for the long term storage of reactor compartments are also presented.

Chapter 7 gives a summary of the methods utilised in the removal and renewal of nuclear fuel in the submarine reactors, including transport and temporary storage. After some years, the fuel elements are retrieved from temporary storage and re-embarked on the special service ships for transfer to rail. Eventually the fuel elements are transported to the reprocessing plant RT-1 in Mayak. The economic implications of reprocessing spent nuclear fuel are also described.

Chapter 8 addresses nuclear submarine accidents. Special emphasis is placed on those incidents where nuclear submarines have sunk or where a partial or complete meltdown of the reactor has occurred with the subsequent release of radioactive material.

Russia is not alone in operating nuclear submarines. In the appendix, a survey of all active nuclear submarines of the United States, Great Britain, France and China is given. India is also known to have initiated a nuclear submarine programme.

Even though each chapter covers a specific issue, it is important to keep in mind its context. One of the most serious problems is the lack of regional storage and treatment facilities for radioactive waste. This waste is deposited haphazardly throughout the various navy yards and bases. The establishment of a regional storage facility for spent nuclear fuel, reactor compartments, and liquid and solid nuclear waste is a necessary precondition for carrying out the decommissioning of submarines in an environmentally viable manner. Bellona has not addressed the issue of the location of such a facility. The choices would appear to be between Novaya Zemlya and the coast of the Kola Peninsula. A recurrent theme in this report is the lack of civilian control over the different Northern Fleet nuclear facilities leading to a disregard of international recommendations concerning the handling of nuclear waste. Further planning for the location of a regional nuclear waste storage facility must be placed under the supervision of a Russian civilian agency.



Nuclear reactors of the World

There are five countries in the world today that operate nuclear-powered naval vessels: Russia, the United States, Great Britain, France and China. The submarines of the Western countries typically have only one reactor on board, whereas most Russian submarines are powered by two reactors. Excluding Russia, these nations have 132 nuclear submarines containing the same number of reactors.¹

The Russian Northern Fleet operates 67 nuclear submarines with a total of 115 reactors between them, and two nuclear powered battle cruisers, each of which has two reactors. In addition, there are 52 nuclear submarines with a total of 101 reactors which have been retired from service, but that still contain their nuclear fuel.² Taking into account the approximately 100 reactors amongst the nuclear submarines and nuclear powered surface ships already in service or laid up with the Russian Pacific Fleet, there is a total of 476 naval military reactors, of which almost half belong to the Russian Northern Fleet.

All five of the countries that already possess nuclear submarines are continuing to develop and build new vessels. Russia is building three new Project 885 nuclear submarines (Severodvinsk class), and another nuclear powered battle cruiser is scheduled to be delivered to the Northern Fleet in the course of 1996. In the United States, there are nine nuclear submarines and two aircraft carriers being built. Great Britain is building seven nuclear submarines, while France is developing four nuclear submarines and a new aircraft carrier. China plans to build two entirely new classes of nuclear submarines. India also has

plans to build nuclear powered submarines and has entered into a cooperative venture with Russia to develop the reactors for the new class of submarines. India will thereby become the sixth of the world's nations to be in possession of nuclear submarines.³ (See Appendix I for further information about the nuclear powered vessels of other countries.)

The Murmansk Shipping Company has eight nuclear icebreakers and a nuclear powered container ship from its base in Murmansk on the Kola Peninsula. Between the nine vessels, there are a total of 15 nuclear reactors.⁴ There are four nuclear power plants in operation at Kola Nuclear Power Plant in Polyarny Zori. Hence the Kola Peninsula along with Severodvinsk on the White Sea, has the greatest concentration of nuclear reactors in the world. There is a total of 240 nuclear reactors in this region, with 236 naval reactors on board various submarines and ships and four land-based nuclear reactors at Kola Nuclear Power Plant.

There are 442 reactors in operation at civilian nuclear power plants in 30 different countries around the world.⁵ In addition to these, there are a further 292 research and experimental reactors spread over 58 countries.⁶ There are also approximately ten other active reactors in the world in use for the production of weapons grade nuclear materials. Four of these are located in Siberia.⁷ Thus there is a total of 1 225 operating nuclear reactors in the world. The Russian Northern Fleet accounts for 18 % of the world's total nuclear reactors.

Table 1. Nuclear reactors of the World.

Country	Submarine Nuclear reactors	Inactive submarine reactors with fuel	Military surface ship reactors	Icebreaker reactors	Nuclear power plant reactors	Research reactors
Russia	215	101	8	15	36	22
USA	99	-	20	-	109	73
UK	16	-	-	-	35	8
China	6	-	-	-	3	13
France	11	-	-	-	56	19
Others		-	-	-	203	157
Total	347	101	28	15	442	292

1 Jane's Fighting Ships 1995-96, 98th edition.

2 Kvaerner Moss Technology A.S., Disposal of Russian Nuclear Submarines, January 19, 1996.

3 Jane's Fighting Ships 1995-96, 98th edition.

4 T. Nilsen and N. Bøhmer, Bellona Report No. 1 - 1994.

5 Nuclear Engineering International, World Nuclear Industry Handbook 1996, Surrey 1996.

6 Rolf O. Lingjærde, Kjernekræft Status og Utvikling 1995, Institute of Energy Technology, November 1995.

7 Viking O. Eriksen, Kjernevåpen - Hva Nå? and N. Bøhmer and T. Nilsen, Reprocessing Plants in Siberia, Bellona Working Paper No. 4 - 1995.

The Northern Fleet

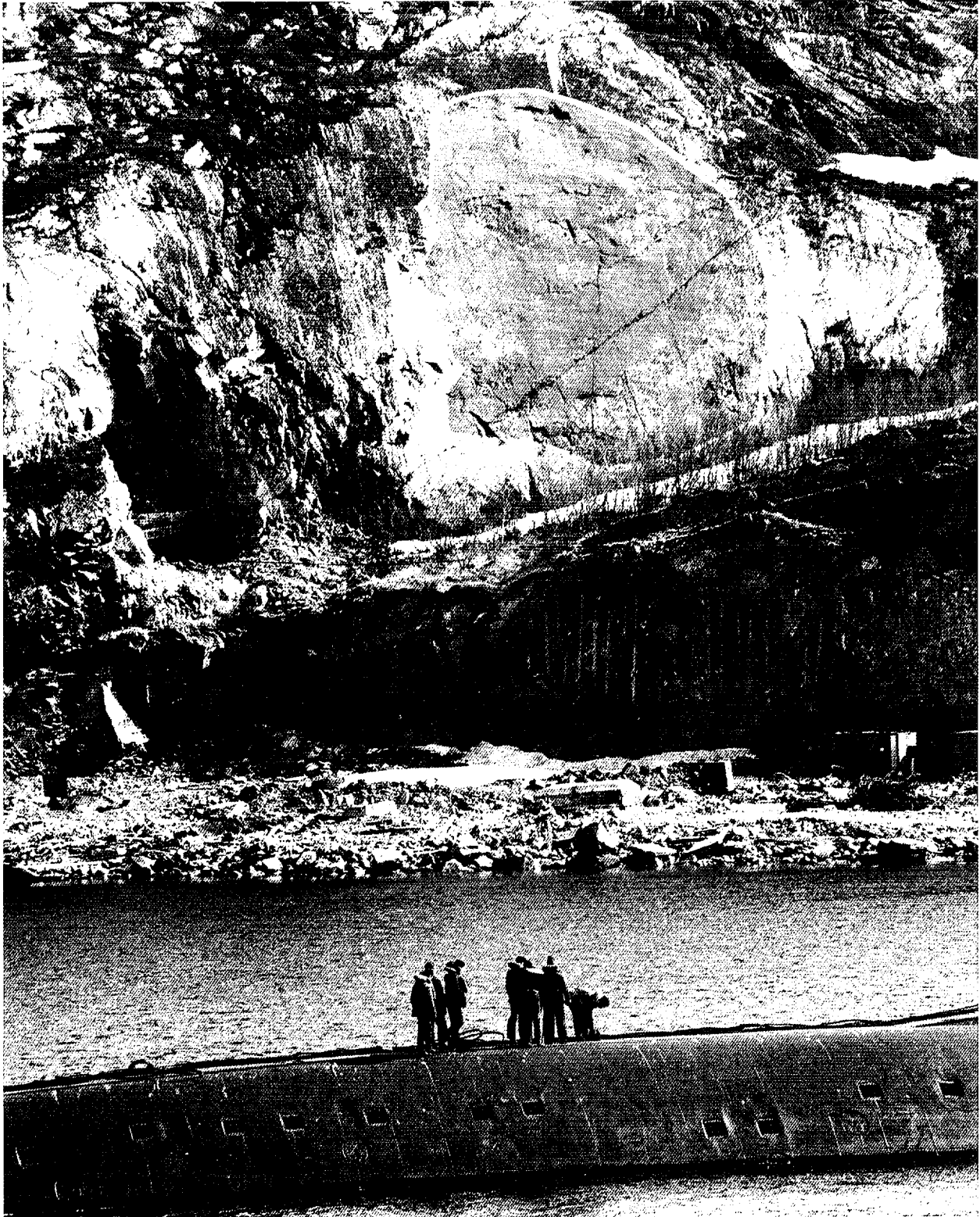

The Northern Fleet

1.1

History

The White Sea and the Barents Sea have been of importance to the Russian merchant fleet ever since the 15th century. The matter of access to ice free harbours in the north became of increasing importance after Germany became a significant naval power in the Baltic Sea. In 1895, construction began on a modern harbour in Aleksandrovsk (present day Polyarny) at the mouth of the Murmansk Fjord. The port was completed in 1899.⁸ Events during World War I increased the strategic importance of the Kola Peninsula to Russia. The Kola Peninsula and the White sea played an important role in the transfer of military supplies to Russia, especially after the German conquest of the coastal areas as far as Estonia during World War I. A naval force dedicated especially to the northern region was established shortly after the outbreak of World War I. When the railway to Murmansk was opened in 1917, the rest of Russia was thereby connected to a ice free port which was open all year. The Soviet Fleet of the Northern Seas was established as a result of Joseph Stalin's visit to Polyarny during the summer of 1933.⁹ In 1937, it was renamed the Northern Fleet. Prior to the outbreak of World War II, the Northern Fleet consisted of eight destroyers, 15 diesel-powered submarines, a formation of patrol boats, mine sweepers and some smaller vessels.¹⁰

During the Russian involvement in World War II (1941-1945), the harbours and ports on the Kola Peninsula were of great importance to the Soviet Union. The *Murmansk Convoys* carried large amounts of materiel and supplies from the western allies to Murmansk. Supplies were transported via railroad to assist the Russian war effort to the south. During the war, the Northern Fleet was given several new ships as well as having vessels transferred from other Soviet fleets. However, most of these were lost during the war.

By the close of the war, the United States Navy had become considerably larger and more powerful than that

of the Soviet Union. In order to catch up with the American head start, the Soviet Union began to build a large naval force of its own. The build-up of a modern fleet on the Kola Peninsula began towards the end of the 1950s. World War II use of submarines had shown the tactical and strategic possibilities of this weapon to advantage. However, the diesel submarines were severely handicapped in their inability to remain permanently submerged. This necessitates spending long periods on the surface, running the dieselengines in order to charge the batteries which powered the vessel when submerged.

The decision to develop and build nuclear submarines therefore constituted an important strategic turning point for the Soviet Navy, and the resolution to pursue this course was adopted by the Supreme Soviet on December 21, 1952.¹¹ In 1954, the first American nuclear submarine *USS Nautilus* was commissioned. Construction of the first Soviet nuclear submarine *K-3 Leninsky Komsomol* began in Molotovsk (now known as Severodvinsk) on September 24, 1955. The submarine was launched on August 9, 1957, and it was commissioned to the Northern Fleet on July 1, 1958. On July 3, she sailed out into the White Sea, and her reactors were started up for the first time on July 4, 1958. The submarine sailed to her base at Malaya Lopatka in Severomorsk-7 (now known as Zapadnaya Litsa) at which she would be stationed. In the period from 1950 to 1970, the Northern Fleet grew from having been the smallest to the largest and most important of the four Soviet fleets.¹² Six new naval bases some with nuclear submarine facilities were built on the Kola Peninsula from Zapadnaya Litsa in the west to Gremikha in the east. A number of smaller navy bases for other types of vessels were also established at the Pechenga Fjord in the west, Belomorsk to the east and Novaya Zemlya to the north. At the same time, five large naval yards were built on the Kola Peninsula and in Severodvinsk for the construction and maintenance of nuclear submarines. It was not long before the size of the Soviet fleet of nuclear submarines had surpassed that of the United States, with about two thirds of all Soviet submarines based with the Northern Fleet.

8 Skogan, J. K., *Rusland og betydningen av Kola-halvøya i historisk lys*, 1992.

9 Osipenko, L., Zhiltsov, L., and Mormul, N., *Atomnaya Podvodnaya Epopeya*, 1994.

10 Ibid.

11 Decree no. 570-2011, December 21, 1952, signed by Joseph Stalin in Moscow. Referenced in L. Osipenko, L. Shiltsov, and N. Mormul, *Atomnaya Podvodnaya Epopeya*, 1994.

12 Skogan, J. K., *The Soviet Union's Northern Fleet 1968-85*, NUPi Report no. 105, 1986.

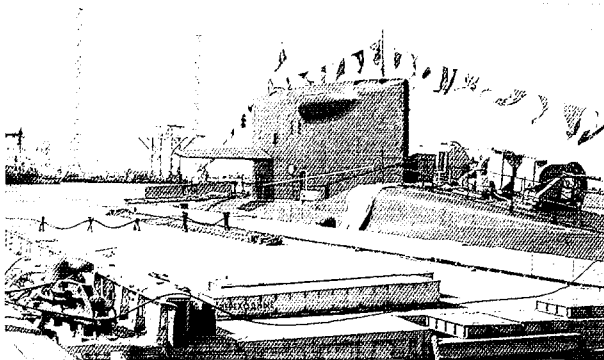

Strategic submarine in Severodvinsk with flags, celebrating the Navy's day

Since 1958, there have been four generations of nuclear submarines and a number of nuclear-powered experimental submarines. The nuclear submarines are built at four different shipyards. By 1995, 245 nuclear submarines and four nuclear-powered surface ships had been delivered to the Navy. Two thirds of these vessels were delivered to the Northern Fleet, whereas only one third of the nuclear submarines were destined for the Pacific Fleet.¹³ The first nuclear submarines to be assigned to the Pacific Fleet were delivered in 1961.¹⁴ Nuclear submarines have never been assigned to the other two fleets of the Soviet Union, the Black Sea Fleet and the Baltic Sea Fleet. During the entire Soviet period, the expenses of the Navy were always covered by the state, and the Northern Fleet never had to contend with economic difficulties or problems in financing new projects.

1.2

Organisation and responsibilities¹⁵

The commander in chief of the Russian Navy is Chief Commander Feliks N. Gromov. The commander in chief of the Northern Fleet is Admiral Oleg A. Yerofeev. The Northern Fleet is organised into departments, each of which has a special area of responsibility. For example, the Technical Department with its offices in the Rosta district of Murmansk is responsible for day to day storage of nuclear waste and for the security of the nuclear submarines at Kola, whether in service or inactive.

The Russian Navy is responsible for the nuclear submarines as long as they are in active service or are moored at one of the Northern Fleet's naval bases. The Navy is also responsible for the three shipyards that service and maintain the nuclear submarines. Otherwise, the state committee for the defence industry (*Goskomobronprom*) is in charge of the other shipyards. The Rus-

sian Ministry for Atomic Energy (*Minatom*) is responsible for the nuclear fuel that is used in the naval reactors, from the delivery of new fuel to the base to the receipt and reprocessing of spent nuclear fuel. The Russian Ministry of Transport is responsible for the freight of new and spent nuclear fuel by railroad.

In addition to the organisations mentioned above, there are a number of other state organisations and ministries which are responsible for ensuring that prescribed procedures are adhered to and correctly executed. The Ministry of Environment, the Ministry of Public Health, the Radiation Protection Authority *Gosatomnadzor* and the state committee for monitoring the public health along with the Ministry of Defence are responsible for working out nuclear safety regulations on board Navy vessels and storage/processing facilities for radioactive waste. The Ministry of Defence's internal regulatory authority is responsible for ensuring that these regulations are adhered to. In earlier years, *Gosatomnadzor* had partial responsibility for monitoring nuclear safety at the naval bases. (See Chapter 4). The Ministry for Situations of Emergencies is charged with averting and mitigating disasters.

In later years, a number of semi-private commercial companies have also appeared, especially in work entailing the dismantling of obsolete submarines and other naval vessels.

1.3

The Northern Fleet today

The Russian Northern Fleet has undergone some significant changes since 1989. With the disintegration of the Soviet Union in 1991 and extensive political reforms and changes in Russia came the end of the Cold War. There have been numerous disarmament agreements between the United States and Russia, including the START I and START II treaties. Military doctrine in both countries has changed, and a large part of the original military industrial complex is in the process of converting to civilian free-market production. The number of strategic submarines and nuclear warheads has been reduced, and the numbers will probably continue to decrease in the years ahead.

The year 1989 was the year in which the Soviet Navy had its largest number of nuclear submarines in operation ever - 196 in total. Now in 1996, there are 109 nuclear submarines in service, of which 67 belong to the Northern Fleet.¹⁶ Other sources state the total of operational nuclear submarines in the Northern Fleet to be 84.¹⁷ It is this latter number on which the START II tre-

13 Pavlov, A. S., *Military Vessels in the Soviet Union and Russia 1945 - 1995*, 1994.

14 *Krasnaya Zvezda*, January 28, 1995.

15 Kvaerner Moss Technology as., *Disposal of Russian nuclear submarines*, January 19, 1996.

16 Calculations made from Pavlov, A. S., 1994, and *Jane's Fighting Ships 1995-96*, 98th edition.

17 *Nevskoye Vremya* (St Petersburg), February 22, 1996, and *Jane's Fighting Ships 1995-96*, 98th edition

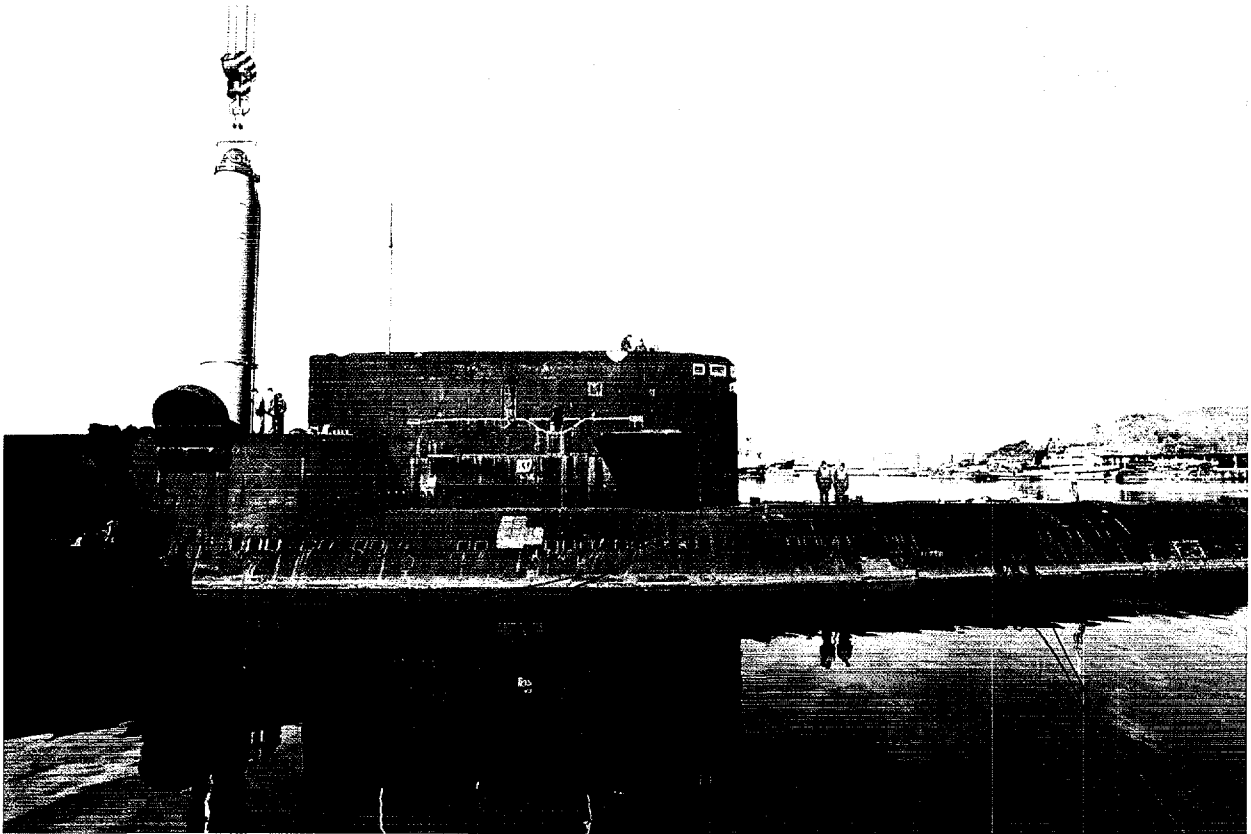

In accordance with the START-II disarmament treaty, the number of strategic missiles on board Northern Fleet submarines will be reduced to a total of 1 750 by the year 2003. Most likely the number will be even smaller. Here a strategic nuclear missile is removed from a Delta-II class submarine at a naval base on the Kola Peninsula. Once their missiles have been removed, the nuclear submarines are then laid up.

aty bases its overview for the present year. The reason for the difference between the two figures is that a number of nuclear submarines have been laid up without being considered actually out of service. Since the dissolution of the Soviet Union, western intelligence has always given a higher figure for the number of operational Russian nuclear submarines than correct.¹⁸ The number of operational submarines in the Russian Navy will probably drop to approximately 80 by the year 2003.¹⁹ The proportional allotment of these submarines between the Northern Fleet and the Pacific Fleet is unknown, but it seems most likely that the Northern Fleet will remain the larger of the two for the foreseeable future.

Military doctrine has also changed within the Northern Fleet. Once an ocean-going fleet of world-wide influence, its principal mission today is to defend the Russian borders. To illustrate, the patrolling activity of the Northern Fleet in the Atlantic Ocean today has been reduced to 20% of what it used to be only a few years ago.²⁰

Prior to the dissolution of the Soviet Union, nuclear

submarines of the Soviet Navy patrolled both the East and West Coasts of the United States, the South China Sea and outside the Persian Gulf. Nowadays it is seldom that a Russian nuclear submarine will patrol in any of these waters.²¹ Towards the end of 1995, increased Russian submarine activity was registered off the north-western coast of the United States, and Project 971 - Akula class nuclear submarines were discovered in international waters just outside the Bangor Naval Base in Washington state. In 1995 Submarines of the Akula class were also noticed off the east coast of the United States. In the same year, Project 949 A - Oscar-II-class submarines followed American aircraft carriers in both the Atlantic and Pacific oceans on a number of occasions.²² At the same time, American submarines continue to patrol close into Russian territorial waters outside the Kola Peninsula.²³ A foreign nuclear submarine was discovered off the Kola coast as recently as March 1996.²⁴

Since 1989, the number of naval vessels in the Northern Fleet has been reduced by 40%. In addition, numerous ships have been placed on reserve, including a number of nuclear submarines. The number of crew has

18 *Nezavisimaya Gazeta*, "The Fleet that we Lost", January 1996.

19 Office of Naval Intelligence, *Worldwide Submarine Proliferation in the Coming Decade*, 3rd version, May 1995.

20 *Nezavisimaya Gazeta*, April 22, 1995, interview with commander-in-chief of the Northern Fleet, Admiral Oleg A. Yerofeev.

21 Office of Naval Intelligence, *World-wide Submarine Proliferation in the Coming Decade*, 3rd version, May 1995.

22 *Jane's Defence Weekly*, January 3, 1996.

23 *Nezavisimaya Gazeta*, April 22, 1995, interview with commander-in-chief of the Northern Fleet, Admiral Oleg A. Yerofeev.

24 Interfax, March 14, 1996.

25 Office of Naval Intelligence, *World-wide Submarine Proliferation in the Coming Decade*, 3rd version, May 1995.



The Northern Fleet has two such nuclear powered battle cruisers, and a third will be delivered over the course of 1996. Due to technical problems, the battle cruisers have been laid up over the past three to four years. These vessels are based at Severomorsk on the Murmansk Fjord.

been reduced, and the Northern Fleet staff has been reorganised.²⁵ All of the first generation nuclear submarines (November, Echo, and Hotel classes) and 60 % of the second generation vessels (Victor, Charlie, Yankee, and Delta) classes are no longer in service. The number of surface ships in the Northern Fleet has been dramatically reduced, but only the oldest and most worn out of the vessels have been taken out of service altogether. According to Russian naval authorities, there are no plans to develop any further generations of nuclear submarines²⁶. However, the fourth generation of nuclear submarines, the Severodvinsk class, is presently under development and will probably enter service in 1998.²⁷

1.3.1 Economic conditions

Large parts of the former Soviet military industry are scheduled to be converted to civilian production, and the naval shipyards are no exception. Construction of nuclear submarines has halted at three of the four yards that formerly had this task. Other shipyards that used to build vessels for the navy now lie outside Russia's borders, including the shipyards at Sevastopol, Nikolaev,

and Kerch which are all in the Ukraine. The construction of the new nuclear-powered battle cruiser *Pyotr Veliky* at the Baltiyskaya yard in St. Petersburg was postponed for several years until it finally underwent sea trials for the first time towards the end of 1995.

The Northern Fleet lacks the funds to carry out the necessary servicing and maintenance on its operational submarines. Subsequently, many of them remain in port.²⁸ For lack of servicing, the Northern Fleet's two nuclear-powered battle cruisers *Admiral Ushakov* and *Admiral Nakhimov* also remained in port for the whole of 1994 and 1995. *Admiral Ushakov* has not been at sea since sustaining machine damage in 1991, while *Admiral Nakhimov* has been moored for the last three years. Both ships are based in Severomorsk.²⁹ The Northern Fleet Command asserts that the lack of maintenance on the nuclear submarines and other naval vessels leads to an inability to fulfil the terms of the present military doctrine.³⁰

In 1994, only 35% of the funds especially earmarked for the Northern Fleet, were actually transferred.³¹ According to the 1994 budget, 600 billion roubles should have been transferred to the Northern Fleet, but

26 *Nezavisimaya Gazeta*, April 22, 1995, interview with commander-in-chief of the Northern Fleet, Admiral Oleg A.Yerofeev.

27 *Jane's Fighting Ships 1995-96*, 98th edition.

28 *Ibid.*

29 *Jane's Defence Weekly*, November 4, 1995.

30 *Nezavisimaya Gazeta*, April 22, 1995, interview with commander-in-chief of the Northern Fleet, Admiral Oleg A.Yerofeev.

31 *Murmansky Vestnik*, January 5, 1995.

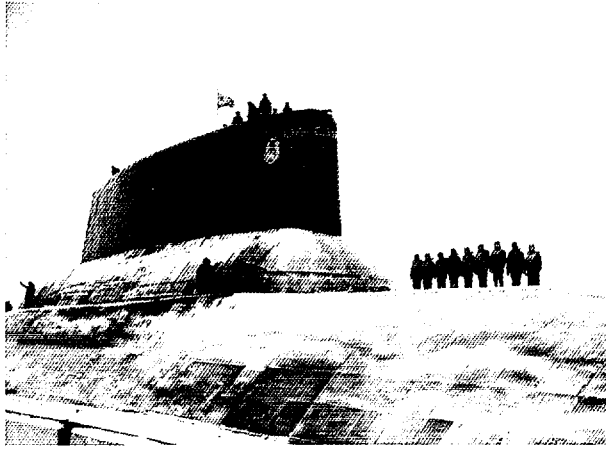

Due to the Northern Fleet's considerable economic problems, crews on board the nuclear submarines do not always receive their salaries on schedule. On numerous occasions, nuclear submarines have been sent out on patrol without the full complement of qualified officers.

this was never actually done.³² The funds that were transferred went largely to pay wages and to cover social services for Northern Fleet personnel. 1995 was an even harder year than 1994. Due to high inflation, the Northern Fleet's entire annual budget was spent within the first six months of the year,³³ forcing severe cut-backs on the operation and maintenance of ships and naval bases.³⁴ On several occasions, the payment of wages was delayed, and this resulted in naval officers refusing to go to sea on patrol duty. There have been several instances over the past two years where the Northern Fleet was obliged to recruit officers from various neighbouring bases in order to assemble a crew for a ship due to go out on patrol. At times, even the nuclear submarines have been sent out on patrol without the full complement of officers.³⁵ It has become quite common that officers are not paid when they go on vacation. In 1995, the wages of naval officers at Zapadnaya Litsa for the months of June, July and August were not paid until September. Even now in 1996, the wages for the first months of the year were delayed for several months.³⁶

At present, the Northern Fleet is unable to pay for the services formerly provided by the state. Many of the companies and shipyards whose services are directed towards the activities of the Northern Fleet receive no economic assistance from the state either, and must try to survive according to the economic principles of the free market. In January 1996, the Northern Fleet owed 40 billion roubles in wages to workers at the various shipyards and other factories. The Northern Fleet's total debt to the

shipyards is in the realm of 200 billion roubles.³⁷

On September 21, 1995, the power company *Kolenergo* shut off electricity to the naval base Gadzhievo as well as to the weapons storage facilities there. This action was precipitated by a long-standing unpaid electricity bill amounting to about 4.5 million USD. Power was restored again 40 minutes later when the Northern Fleet sent armed guards to the transformer station.³⁸ The Northern Fleet Command later stated that never again would *Kolenergo* dare to shut off the power.³⁹ On September 26, the power was again shut off for 20 minutes, this time at the military shipyard *Sevmorput*.⁴⁰

Admiral Yerofeev has suggested a number of measures by which the Northern Fleet might earn funds and improve its economic condition until the political situation in Russia stabilises. For example, the Northern Fleet could sell a number of its ships to other countries and retain for itself the proceeds of the sale. Training of the crew for these ships could also raise income for the Northern Fleet. However, according to present rules, this kind of extra income can only be used towards welfare or social benefits for the officers.⁴¹

Another way to improve the financial situation would be to permit the naval shipyards to carry out the dismantling of naval vessels and sell the salvaged metals for scrap. The Northern Fleet is also considering renting/leasing to non-military research institutions engaged in scientific research in the Arctic region. For example, in June 1995, Germany used one of the Northern Fleet's Delta-III submarines to launch an experimental rocket. The launch took place just outside the Gremikha naval base in the southern part of the Barents Sea. The experimental rocket was launched from a depth of 50 meters on an RSM-50 (SS-N-18) type booster. This type of booster was originally designed to launch nuclear warheads, but is now obsolete. The German experimental launch was the second such venture for the Northern Fleet; the first took place in 1994. On this occasion, the Northern Fleet worked with the Russian space centre, and was only paid for the time that the submarine was in use. However, the Northern Fleet was willing to accept these terms, for it presented an opportunity to train the crew in an unusual exercise, an opportunity they would not otherwise have had.⁴²

In August 1995, a Northern Fleet Project 671 RTM submarine (Victor-III class) was used to transport potatoes and fruit from the Kola Peninsula to the Yamal Peninsula on the northern coast of Siberia. The missiles had been removed from the missile compartment to increase the cargo space for potatoes.⁴³ The concept of

32 Northern Fleet's Press release, September 22, 1995.

33 *Na Strazhe Zapolyarya*, April 19, 1995.

34 *Na Strazhe Zapolyarya*, April 19, 1995.

35 *Morskoy Sbornik*, no. 6, 1995 and no. 12, 1994.

36 Vladimir Pyzh, Northern Fleet spokesman to the press, Severomorsk, March 5, 1996.

37 *Polyarnaya Pravda*, January 24, 1996.

38 *Polyarnaya Pravda*, September 26, 1995.

39 Northern Fleet Press Release, September 22, 1995.

40 Radio Murmansk, September 27, 1995.

41 *Ibid.*

42 *Izvestiya*, June 3, 1995.

43 *Rossiyskaya Gazeta*, September 14, 1995.

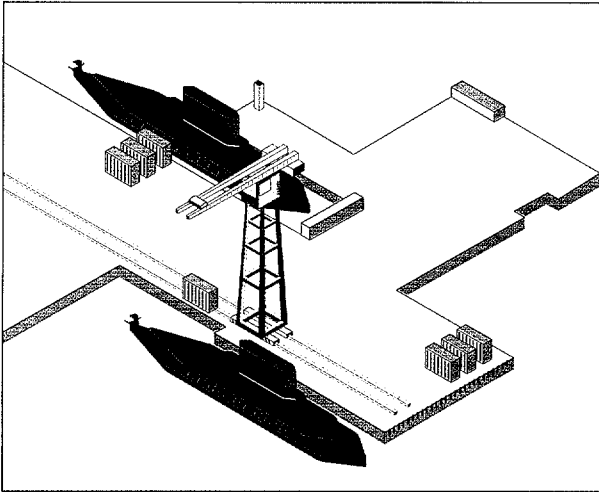

The company *Sudoexport* has developed plans to rebuild military nuclear submarines into civilian nuclear powered container carrying submarines with the intent of utilising them along the Northeast passage from North-western Russia to the markets in Asia.

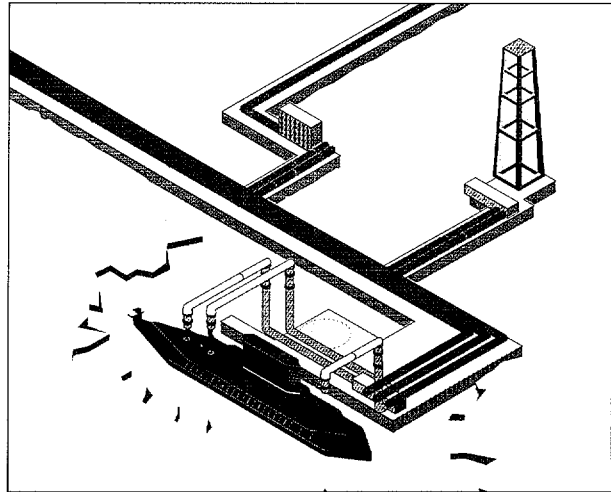

Plans exist to rebuild military nuclear submarines into civilian oil tanker submarines for use especially in the development of new oil fields along the coast of Siberia. The oil tanker submarines would be used in waters impassable to ordinary oil tankers due to the ice conditions.

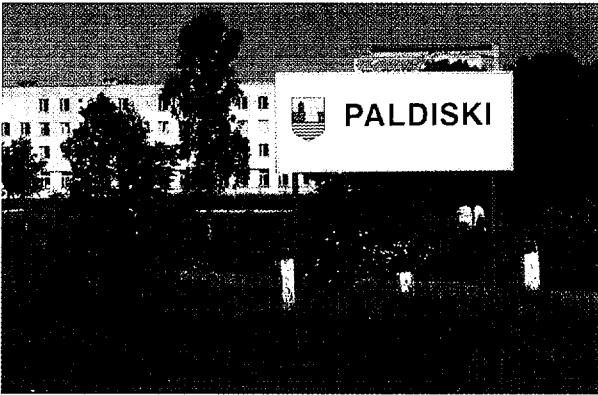

Many of the Soviet Union's submarine officers were trained at the naval colleges in Sevastopol (Ukraine) and here at Paldiski (Estonia). Following the dissolution of the Soviet Union, these establishments were closed. At the present time, work is ongoing in Paldiski to dismantle the two nuclear submarine models which include the reactors.

using military nuclear submarines to transport civilian cargo is under further study, thus there have been no conclusions. The Russian Navy emphasises that the use of military vessels for civilian commissions is only intended as a temporary stopgap in the transitional period until the economic situation has stabilised.⁴⁴

Other opportunities may arise with the development of the oil and gas fields in the Arctic seas. Nuclear submarines could possibly be used in geological studies and to transport oil. The Moscow-based company *Sudoexport* has presented plans to rebuild nuclear submarines into civilian oil tankers.⁴⁵ The transport route would run from the oil terminals along the northern coast of Siberia and Arkhangelsk County to various oil ports. Each submarine is estimated to have a carrying capacity of 830 tons and with a crew of 35 men. For entry into the harbours of countries that either prohibit or do not desire visits from nuclear-powered vessels, the diesel engines

could be used inside the harbour areas. The same company has also presented plans to rebuild nuclear submarines into civilian container ships.⁴⁶ Transport routes of particular interest are the passages from Northern Europe to Asia. The submarine's ability to travel submerged makes it independent of ice conditions at sea and permits an even more rapid transit time between east and west. Potential cargo capacity is estimated to be 20 containers with a cargo of 900 m³. Tourist cruises in the north on board nuclear submarines have also been considered.

1.3.2 Reduced levels of competence in submarine crews

Until 1991, Soviet submarine crews were trained at three different training centres within the Soviet Union: Paldiski in Estonia, Sevastopol in the Ukraine, and Sos-

44 *Nezavisimaya Gazeta*, April 22, 1995, interview with commander-in-chief of the Northern Fleet, Admiral Oleg A. Yerofeev.

45 *Sudoexport*, *Undersea tanker*, Moscow 1994.

46 *Sudoexport*, *Undersea transport container carrier*, Moscow 1994.

novy Bor outside St. Petersburg. The training centre in Sevastopol was the largest of the three and operated highly advanced computer and reactor simulators, turning out 500 submarine officers a year.⁴⁷ However, ever since the Ukraine achieved independence, the Russian Navy has not utilised this centre. Of all Soviet specialists and operators of naval reactors, 80 percent of them received their training at the naval college in Sevastopol, while the remaining 20 percent were trained at the Dzerzhinsky Naval College in St. Petersburg.⁴⁸

Two mock submarines were built in Paldiski, to represent both the first and second generations (Project 667 BR - Delta-I class and Project 659 - Echo-II class), and each one had a functional naval reactor installed. The Paldiski reactors were shut down in 1989 and both the reactors and the mock submarines are now being dismantled.⁴⁹ Officers for the Project 941-Typhoon class, 667 A - Yankee class and 667 BDRM - Delta I-IV classes were also trained at Paldiski.⁵⁰

The naval training college in Sosnovy Bor outside St. Petersburg has three operational experimental reactors very similar to those installed in the nuclear submarines. Testing of nuclear fuel and the development of naval reactor technology is carried out here. A fourth research reactor is being built.⁵¹ All training of crews and service personnel for nuclear submarines now takes place at Dzerzhinsky Naval College in St. Petersburg. The college has a rather limited capacity, and this has contributed to an overall reduction in the competence of Russian nuclear submarine crews.

The lack of sufficient funds to keep the nuclear submarine fleet running has led to present day officers receiving far less training in operational routines than was the case a few years ago. Furthermore, the deteriorating social conditions and low wages for officers of the Northern Fleet result in fewer and fewer of them electing to renew their five year contracts with the navy, and the heavy turnover of officers reduces the overall level of competence even further.⁵²

The Russian naval officer of today has fallen from being one of the most privileged members of Soviet society to one whose work is far less valued. The 1990s have brought dramatic changes in the social conditions of the Soviet naval officer, few of which have been positive. With the severe cuts in the Russian Navy's budget, special privileges and welfare benefits for navy personnel and shipyard workers have also been sharply reduced.⁵³ The naval shipyards which once worked under state directives, now operate as independent tax-

paying entities who depend on the Navy remunerating the work that has been commissioned. Some of the ship repair crews have not been paid for several months.⁵⁴ Due to a lack of financing, much of the former activity has come to a standstill. As a result, the yard infrastructure is slowly falling apart.⁵⁵ Subsequently, safety levels in the maintenance of both operational as well as inactive submarines are being compromised. One of the more serious breaches in safety is the failure to properly maintain the storage facilities for spent nuclear fuel and radioactive waste. Commander-in-Chief of the Northern Fleet, Admiral Oleg Yerofeev stated in April 1995 that "the problems of storing spent nuclear fuel, radioactive waste, inactive submarines and the lack of servicing for the submarines in active service are a problem not only for the Northern Fleet, but also for the Russian state. Therefore, it would be natural not only for the Fleet to take necessary action, but also for the Ministry for Situations of Emergency, Emercom, also to act. If measures are not taken to address the situation today, over a period of time the situation could become critical and lead to an ecological disaster."⁵⁶

1.4

The future of the Northern Fleet

The future of the Northern Fleet will largely depend on the development of military and political events in Russia. Economic and regional developments in the Arctic region will also affect the fate of the Northern Fleet. Although the entire build-up of the Northern Fleet was a product of the arms race and the Cold War, it is improbable that the Northern Fleet would be reduced to 1950 levels, despite the fact that the Cold War has now ended. The new military doctrine of Russia emphasises that the Northern Fleet's primary mission is to defend Russian territory.⁵⁷

Assuming that the terms of the START-II treaty are fulfilled, by the year 2003 over 50 percent of Russia's strategic nuclear warheads will be carried on nuclear submarines as opposed to just under 25 percent today.⁵⁸ According to the START-II Treaty, a maximum of 1 750 nuclear warheads may be placed on Russian submarines. This means that the number of nuclear weapons onboard submarines as a total will decrease, but the strategic position of the Northern Fleet will be far more

47 *Morskoy sbornik*, No. 1 - 1994.

48 *Morskoy sbornik*, No. 2 - 1993.

49 Bellona inspection, June 22, 1995.

50 *ibid.*

51 *The Baltic Region - Our Habitat*, E-mail newsletter 1995, bodorov@glas.apc.org.

52 *Morskoy sbornik*, no. 7-1994.

53 *Morskoy sbornik*, nos. 3, 9, and 12, 1993 and no. 7, 1994.

54 *Na Strazhe Zapolyarya*, April 19, 1995.

55 *Polyarnaya Pravda*, February 28, 1995.

56 *Nezavisimaya Gazeta*, April 22, 1995, interview with commander-in-chief of the Northern Fleet, Admiral Oleg A. Yerofeev.

57 *ibid.*

58 Office of Naval Intelligence, *World-wide Submarine Proliferation in the Coming Decade*, 3rd version, May 1995.

Table 2. The nuclear balance between the United States and Russia.

II Missile type	Number of Warheads September 1, 1990		Number permitted: START-I After 7 years		Number permitted: START-II 2003
	Soviet Union	USA	After 7 years	After 7 years	2003
Ballistic missiles	9 416	8 210	4 900	Not specified	
Intercontinental missiles	5 958	2 000	1 540	1 200	
Submarine launched missiles	2 804	5 760	Not specified	2 160	1 700 - 1 750
Total	18 178	15 970			

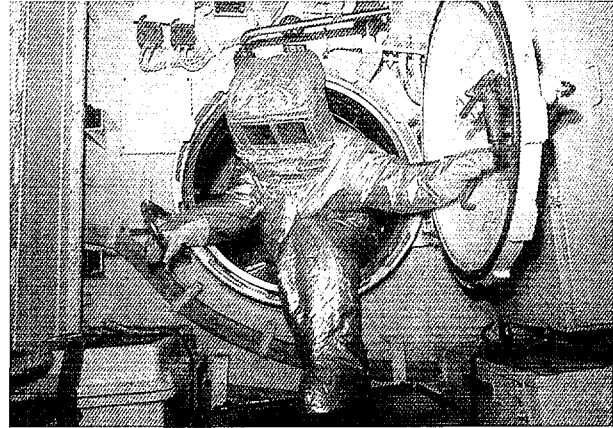

Insufficient training of submarine crews can have serious consequences in the event of an accident. The officer pictured here is being trained in emergency procedures within the reactor compartment of a Typhoon submarine.

important in Russian nuclear strategy than it is today. According to Russian military experts, the Russian Navy in the future will need to retain a maximum of 16 strategic nuclear submarines, 21 attack submarines, and 12 tactical submarines.⁵⁹ Western experts maintain that even fewer submarines will be required.

If the number of permitted strategic nuclear warheads per submarine is decisive for the number of submarines Russia chooses to maintain in service, the six Project 941 - Typhoon class submarines in combination with seven submarines from the Project 667 BDRM - Delta-

IV class should prove sufficient. These 13 nuclear submarines can carry 1 750 nuclear warheads between them; however, it seems unlikely that Russia would choose a defence system based solely upon strategic nuclear submarines. A new Project 971 - Akula class attack submarine is scheduled for delivery in 1996.⁶⁰ Furthermore, there are three nuclear submarines of the new Project 885 - Severodvinsk class currently under construction, a type that can be used both as a strategic and attack submarine.⁶¹

The reduction in the number of nuclear warheads as a result of the START-I and START-II Treaties is shown in the table below. The table also compares the nuclear balance between the United States and Russia, as well as the distribution of nuclear warheads on land and at sea.⁶²

The future number of strategic submarines in the Northern Fleet will ultimately depend on the development of the political and economic situation in Russia.⁶³

Some of the largest challenges facing the Russian Navy at this time are the problems associated with the

59 *Nezavisimaya Gazeta*, April 22, 1995, interview with commander-in-chief of the Northern Fleet, Admiral Oleg A. Yerofeev.

60 *Severny Rabochy*, January 19, 1995.

61 *Jane's Fighting Ships 1995-96*, 98th edition.

62 *Nezavisimaya Gazeta*, February 10, 1996.

63 *Krasnaya Zvezda*, April 15, 1995.



If the START-II treaty is fulfilled, 50 percent of Russian strategic nuclear warheads will be placed on submarines in 2003. This means that the Northern Fleet will play an even more important role within the Russian nuclear strategy. Many of the nuclear missiles will be carried by submarines of the Delta class, seen in this picture.



LOWERED SOCIAL CONDITIONS: The social conditions for officers of the Northern Fleet have worsened considerably in the nineties. At times, several months pass between each pay day. Consequently, the number of officers renewing their five year contracts with the navy is diminishing. On several occasions, nuclear submarines on patrol have sailed with fewer qualified officers than regulations provide. This severely weakens the safety on board.



CLUSTERED TOGETHER IN TIGHT ROWS: At the Naval base Gadzhievo on the Kola Peninsula, strategic and attack submarines are stationed. During the Cold War more than 240 nuclear submarines were put to operation within the Soviet Union. The numbers have been severely reduced during later years; today the Northern Fleet operates 67 nuclear submarines. The real challenge of today is to ensure secure demolishing and storage of all the submarines that have been and will be taken out of operation. The balance of these are today rusting in at the Naval bases along the Kola coast and in Severodvinsk.

FOR SCRAPPING this officer is painting on the ballistic nuclear missile from a nuclear submarine. The missiles being taken out of Northern Fleet submarines are temporarily stored, among other places, here in the Okolnaya bay, north of Severomorsk. To the right in the

background, the simple fence protecting the nuclear missiles against intruders is discernible. The missiles are stored out in the open, during the summer as well as the winter. The old nuclear warheads of these missiles are to be transported to storage facilities in Siberia.

TORPEDOES WITH NUCLEAR WARHEADS: On board the gigantic Typhoon submarines, a storage room contains torpedoes ready to be armed with nuclear warheads, to be fired at other submarines in battle. Each Typhoon can carry 18 of these torpedoes.

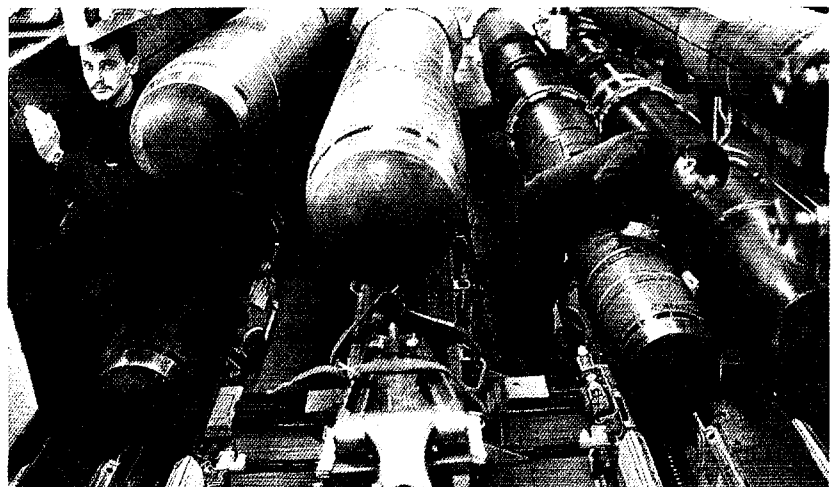

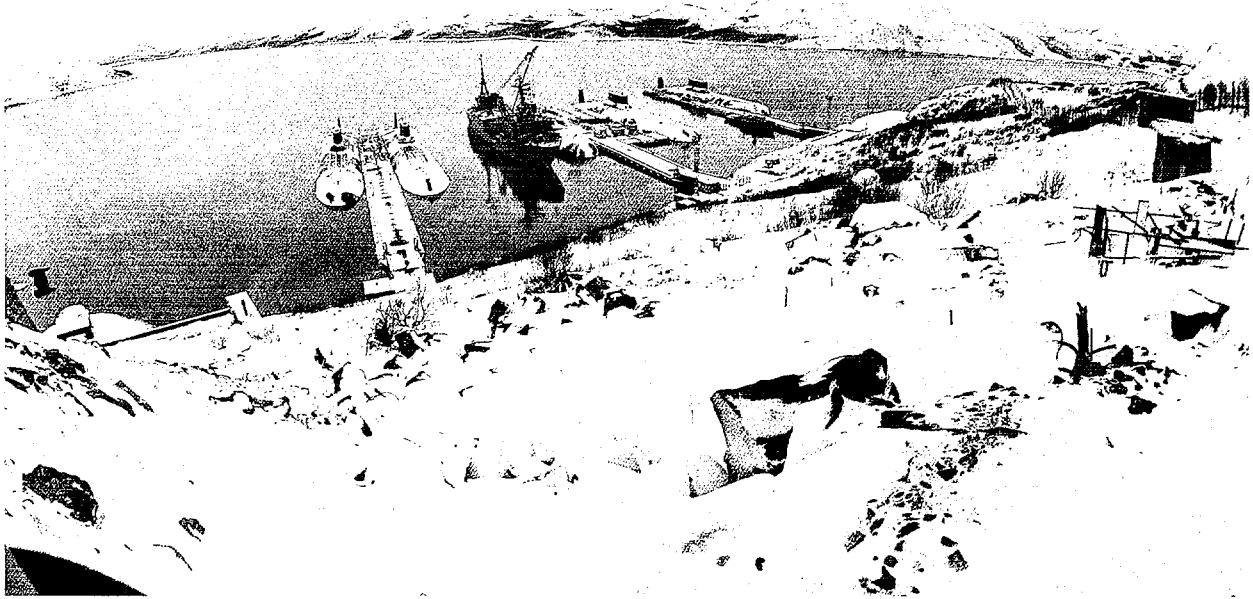

45 KILOMETRES FROM NORWAY: This is the Northern Fleet nuclear submarine base situated closest to the Norwegian border. Accidents within the reactors on board these submarines, or on some of the nuclear waste storage facilities located in the same fjord, may lead to radioactive contamination reaching the populations of both the Kola Peninsula and Northern Norway. Civilian Russian authorities are still not allowed entrance to these military bases to inspect the nuclear safety.

decommissioning of ageing submarines and the storage and transport of spent nuclear fuel and radioactive waste. According to the Russian Ministry of Defence, at the present level of funding it will be impossible to solve any of these problems. At present, plans exist only on paper as to how to execute the work through the years 2005-2010.⁶⁴ Yet the task of dismantling the force of ageing submarines must be seen in a much longer perspective. The overhanging danger of accidents and

radioactive leakage from laid up nuclear submarines increases from year to year, and both from an environmental and economic perspective, it is important that the decommissioning of nuclear submarines and the securing of storage facilities for spent nuclear fuel and radioactive waste is undertaken quickly. Otherwise, as the technical condition of these vessels and installations continues to deteriorate, it will become far more expensive to solve the problems associated with them.⁶⁵

⁶⁴ *Murmansky Vestnik*, March 15, 1995.

⁶⁵ *Krasnaya Zvezda*, July 13, 1995.

Nuclear-powered vessels

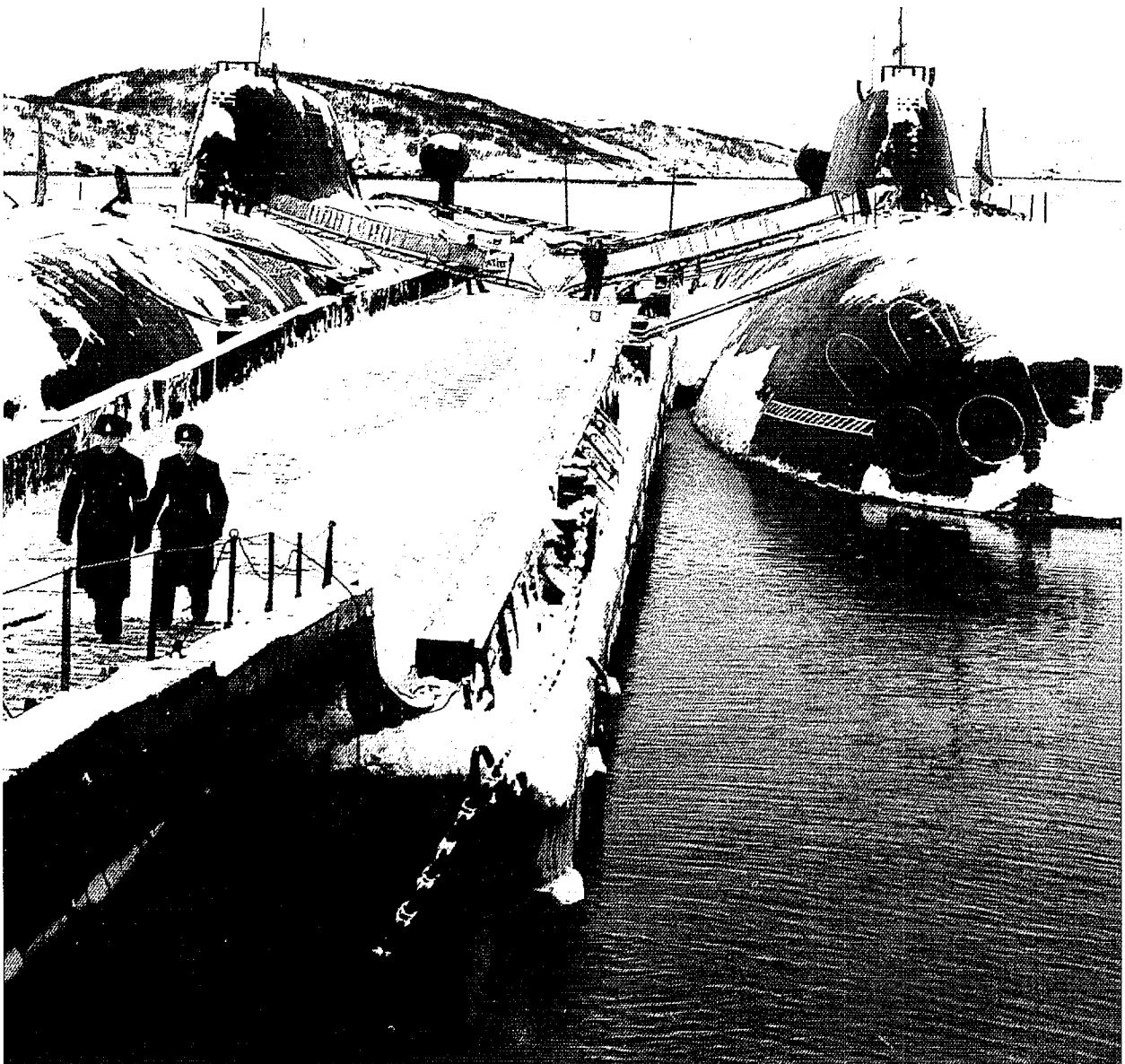

Chapter 2.

Nuclear-powered vessels

In the former Soviet Union/Russia, 247 nuclear submarines and five nuclear-powered surface ships were built in the period from 1955 to 1996.⁶⁶ In addition, a nuclear reactor which can be installed in diesel powered submarines was also built. Nuclear powered naval vessels are in service with the Northern Fleet (2/3) and with the Pacific Fleet (1/3), but have never been assigned to either of the other two Russian Fleets (the Black Sea Fleet and the Baltic Fleet.) Until the end of the 1980s, the Soviet Navy had more nuclear submarines than all other countries put together.⁶⁷ As a result both of the START II disarmament treaty and the high age of some of the earlier generations of Soviet submarines, 138 Russian submarines are now no longer operative. This number is expected to increase over the years to come as more of the ageing classes of submarines are decommissioned and dismantled. At the present time, there are 67 nuclear submarines and two nuclear-powered battle cruisers in service with the Northern Fleet, while in the Pacific Fleet, there are 42 operative nuclear submarines, one nuclear powered battle cruiser, and one nuclear powered communications ship.⁶⁸

2.1 Construction of nuclear powered submarines and surface ships

2.1.1 Design Bureaus

Soviet nuclear submarines are designed by three main design bureau's, each of which has several subdivisions. The first Soviet nuclear submarine was designed by *Special Design Bureau No. 143* (SKB-143). This bureau later merged with SKB-193 and SKB-16 and formed *Malakit Design Bureau* in St. Petersburg. SKB-143

Table 3. A summary of the Design Bureaus

Design Bureau - Location	Project No./NATO - class
<i>Malakit Design Bureau</i> (SKB-143) St. Petersburg	627 A - November
	645 ZhMT
	671 - Victor class
	705 - Alfa
	971 - Akula
661 - Papa	
<i>Rubin Central Marine Designs Bureau (SKB-18)</i> St. Petersburg	658 - Hotel
	659 - Echo I
	675 - Echo II
	667 - Yankee
	667 B - Delta I
	667 BD - Delta II
	667 BDR - Delta III
	667 BDRM - Delta IV
	941 - Typhoon
	685 - Mike
885 - Severodvinsk	
<i>Lazurit (STB-112)</i> Nizhny Novgorod	670 - Charlie I-II
	945 - Sierra

designed the Project 627 A-November class, Project 645 ZhMT, Project 671 - Victor class, Project 705 - Alfa class, Project 971 - Akula class and Project 661 - Papa class attack submarines. *Rubin Central Marine Designs Bureau (SKB-18)* in St. Petersburg designed the Project 658 - Hotel class, Project 659/675 - Echo I-II class, Project 667 - Yankee and Delta I-IV classes, Project 941 - Typhoon class, Project 685 - Mike class and the forthcoming Project 885 - Severodvinsk class submarines. The construction bureau *Lazurit (STB-112)* in Nizhny Novgorod developed the Project 670 - Charlie class and Project 945 - Sierra class nuclear submarines.⁶⁹

66 Pavlov, A.S., *Military Vessels in the Soviet Union and Russia 1945-1995*, and *Jane's Fighting Ships 1995-1996*, 98th edition.

67 *Nezavisimaya Gazeta*, October 25, 1994.

68 *Jane's Fighting Ships 1993-1994* lists 49 nuclear submarines in the Pacific Fleet as operative. The actual number is probably around 25 to 30. Source: Handler, J., Greenpeace, *Radioactive Waste Situation in the Russian Pacific Fleet, Nuclear Disposal Problems, Submarine Decommissioning, Submarine Safety, and Security of Naval Fuel*, p. 35. October 27, 1994.

69 Bukharin, O., and Handler, J., *Russian Nuclear-Powered Submarine Decommissioning*, 1995.

2.1.2 Shipyards

In the former Soviet Union, nuclear submarines were built at four different shipyards.⁷⁰ One of these, Sev-mash (formerly shipyard No. 402) in Severodvinsk, has been operative since 1955. The *Amursky* Yard (formerly shipyard No. 199) at Komosomolsk-na-Amur was operative from 1957, and has a subdivision in Bolshaya Kamen near Vladivostok. Nuclear submarines have also been built at *Krasnoye Soromovo* (formerly shipyard No. 112) in Nizhny Novgorod and at the Admiralty Yard (formerly shipyards No. 194 and 196) in St. Petersburg since 1960.⁷¹

At each of these four shipyards, approximately five to ten nuclear submarines were built a year until 1992. Today, only the Severodvinsk yard is in operation with a maximum production of one or two submarines a year. Of the four yards, Severodvinsk turned out the largest number of nuclear submarines with a total of 127 vessels.⁷² Komosomolsk-na-Amur produced a total of 56 submarines, 39 were produced in St. Petersburg and 25 in Nizhny Novgorod.⁷³ Some of the submarines built in Nizhny Novgorod and St. Petersburg were transported by the Volga and Karel canals to Severodvinsk for completion, ostensibly weapons fitting and reactor equipment.⁷⁴

2.2

Technological development of nuclear-powered vessels

The Soviet resolution to build nuclear submarines was adopted in a state decree dated December 21, 1952.⁷⁵ At this time, research and development of reactor technology was already in progress. A pressurised water reactor was built at the Obninsk Centre outside Moscow, and shortly thereafter a liquid metal cooled reactor also came on line. Both reactors were used for testing reactor technology and for the training of submarine crews. Later the men trained here would be transferred to Soviet Union's first nuclear submarines.

The selection and training of the first nuclear submarine crews began in 1954. In 1955, the first naval reactor in Obninsk was started and training of recruits for the first two nuclear submarines K-3 and K-5 begun. Naval recruits for the submarines K-8, K-14 and K-19 were trained the following year. Simultaneously, a liquid

metal cooled reactor prototype was started up for the purposes of training personnel for the submarine K-27.⁷⁶

Construction of the first Soviet nuclear submarine K-3 (*Leninsky Komsomol*), a Project 627 A - November class vessel, started September 24, 1955, in Molotovsk (Severodvinsk).⁷⁷ The submarine was launched August 9, 1957, and the two reactors started up for the first time between July 3-4, 1958.⁷⁸ The first American nuclear submarine *USS Nautilus* was commissioned three years earlier on January 17, 1955. Since the United States had a three year head start, the Soviet Union decided to commission K-3 even before the reactor test results were in.⁷⁹ Nuclear-powered submarines enabled both the United States and the Soviet Union to carry nuclear weapons close to their mutual coastlines unnoticed. Indeed, the placing of nuclear missiles onto nuclear submarines became a significant contributing factor to the arms race.

2.2.1 First generation nuclear-powered submarines

The first generation Soviet naval submarines included: Project 627 A - November class, 658 - Hotel class, 659 - Echo-I class and 675 - Echo-II class. In total, from 1955 to 1964, a total of 55 first generation nuclear submarines were built. There were 13 November class, 8 Hotel class, 5 Echo-I class and 29 Echo-II class vessels. With its three ballistic nuclear missiles, the Project 658 - Hotel class submarine, K-19, was the first strategic submarine of the Soviet Union. K-145, a submarine of the same class, was refitted a few years later to carry six ballistic nuclear missiles. The Echo-I/Echo-II class submarines each carried eight cruise missiles. Some of the Echo-II submarines were rebuilt to be able to carry mini submarines. By 1992, all first generation nuclear submarines had been decommissioned.⁸⁰

2.2.2 Second generation nuclear-powered submarines

From 1964 to 1974, the Soviet Union built 34 Project 667 A - Yankee class nuclear submarines. These submarines each carried 16 ballistic nuclear missiles with a range of 3000 kilometres. Having been constructed under the same fundamental principles as the American submarine class *George Washington*,⁸¹ they conse-

70 *Izvestia*, July 13, 1993.

71 Lee, R., *Active Naval Shipyards*, last updated October 24, 1995.

72 Bukharin, O., and Handler, J., *Russian Nuclear-Powered Submarine Decommissioning*, 1995.

73 *Ibid.*

74 Mormul, N., Note, 1995.

75 Decree No. 570-2011 from the Supreme Soviet, December 21, 1952, Moscow. Referred by Mormul, N., Note, 1995.

76 Mormul, N., Note, 1995.

77 Pavlov, A.S., *Military Vessels in the Soviet Union and Russia 1945-1995.*, 1994

78 Mormul, N., Note, 1995.

79 *Morskoy sbornik*, No.1, 1995.

80 Pavlov, A.S., *Military Vessels in the Soviet Union and Russia 1945-1995*, 1994

81 *Krasnaya Zvezda*, January 28, 1995.

quently received the NATO classification "Yankee".⁸² Of these 34 submarines, 10 were assigned to the Pacific Fleet and 24 to the Northern Fleet. The Yankee-class submarines are no longer operative and are presently being dismantled.

The Project 667 B - Delta-I class submarines are a modified version of the Yankee class submarines.⁸³ These submarines have been modified to carry 12 intercontinental ballistic nuclear missiles with a range of 9000 kilometres. Considerable improvements were made to the navigation systems. With the possession of intercontinental missiles, it was no longer necessary to patrol the American coasts. Missiles directed at the American continent could be launched from submarines stationed just off the Kola coast or from patrolling areas beneath the polar ice cap. The successors to the Delta-I class submarines, Project 667 BD - Delta-II, Project 667 BDR - Delta-III and Project 667 BDRM Delta-IV were fitted with 16 intercontinental missiles with a range which enabled them to be launched directly from the submarine's base. These later models of the Delta class were also developed to be considerably quieter than their Yankee and Delta-I class predecessors. This was in direct response to the American construction of the SOSUS listening network, which is a network of submerged cables for the purpose of detecting Russian submarines. The network was laid along the east and west coasts of the United States as well as along the coasts of northern Norway, Greenland, Iceland, the Faeroe Islands and Great Britain.⁸⁴ A total of 43 submarines of Delta I-IV classes were constructed from 1971 to 1992.

Other second generation nuclear submarines include the Project 670 - Charlie class and Project 671 - Victor class. These submarines were developed simultaneously with the Yankee class.⁸⁵ There were 17 submarines in the Charlie-I-II classes, while a total of 48 Victor I-III class submarines were built. A number of these are still in service. The Charlie class submarines are fitted with cruise missiles, and their main purpose is to counter hostile aircraft carriers and surface ships. Submarines of the Victor classes are attack submarines whose objective is to counter enemy submarines.⁸⁶ These vessels are also the first Soviet submarines to be equipped with only one pressurised water reactor.⁸⁷ Today, almost all of the Yankee class submarines have been decommissi-

oned. The other second generation nuclear submarines are gradually being replaced by third and fourth generation submarines.

2.2.3 Third generation nuclear -powered submarines

Construction of the first class of third generation nuclear submarines, the Project 941 - Typhoon class, began in 1977,⁸⁸ and the first of these vessels was taken into service in 1981. By 1989, six Typhoon class submarines had been built, and the vessels in this class are definitively the world's largest submarines, carrying 200 nuclear warheads each. The Typhoon class submarine was developed to ensure the Soviet capability of massive retaliation in the event of a nuclear attack. A seventh Typhoon class submarine was under construction at the Severodvinsk shipyard, but the work was halted, ostensibly due to the political changes in the Soviet Union towards the end of the 1980s.⁸⁹

The third generation of submarines is substantially improved, both in reactor technology, additional and improved electronic equipment, and quieter machinery compared to previous generations of submarines. In 1980, the Northern Fleet's first submarine in the new Project 949 - Oscar I class, went into service. The Oscar class of submarines carry cruise missiles and were designed to hunt down and sink hostile aircraft carriers. The first Project 949 A - Oscar-II class submarine came on stream a few years later. Four attack submarines of the Project 945 - Sierra class, were taken into use between 1984 to 1993. These vessels have a titanium hull.⁹⁰ In 1990, an improved version of the Sierra class, the Project 971 - Akula class came into operation. This is the quietest and most modern submarine in the Russian Navy.⁹¹ Some of the earliest of the Akula class submarines have been modernised to further reduce the noise level,⁹² and the most recently built vessels have been improved to such an extent that they are even quieter than those that were commissioned in 1990. These submarines are classified Akula II and are 4 metres longer than the earlier vessels of the Akula I class.⁹³ Of the third generation nuclear submarines, only the Project 949 A - Oscar-II class and Project 971 - Akula-II class are still under construction.⁹⁴

82 *Severny Rabochy*, January 27, 1994.

83 *Krasnaya Zvezda*, January 28, 1995.

84 *Nezavisimaya Gazeta*, October 25, 1994.

85 *Krasnaya Zvezda*, April 29, 1995.

86 *Krasnaya Zvezda*, January 29, 1995.

87 Pavlov, A.S., *Military Vessels in the Soviet Union and Russia 1945-1995*, 1994.

88 *Krasnaya Zvezda*, January 28, 1995.

89 Pavlov, A.S., *Military Vessels in the Soviet Union and Russia 1945-1995*, 1994.

90 *Na Strazhe Zapolyarya*, April 22, 1995.

91 *Krasnaya Zvezda*, January 28, 1995.

92 Office of Naval Intelligence *Worldwide Submarine Proliferation in the Coming Decade*, (3rd edition), May 1995.

93 *Jane's Defence Weekly*, No. 9, February 28, 1996.

94 *Morskoy sbornik*, No. 7, 1995.

2.2.4 Fourth generation of nuclear-powered submarines

In late December 1993, construction began on a fourth generation of nuclear powered submarines, the Project 885 - Severodvinsk class.⁹⁵ The prototype was launched in 1995, but it is not scheduled to be transferred to the Navy until 1998 at the earliest.⁹⁶ This submarine is even more silent running than those of the Project 971 - Akula class; American experts consider it to be the most advanced nuclear-powered submarine in the world.⁹⁷ There are three Severodvinsk class submarines under construction, and four more are planned.⁹⁸ The latter four have the classification Severodvinsk-I. It is not known how the two submarine projects differ from one another. Construction of this class of vessels will probably begin in 2002-2004 at the Severodvinsk shipbuilding yard, and they will then enter service from 2006-2008.⁹⁹ These submarines will probably be fitted with both strategic and cruise missiles with multiple nuclear warheads.¹⁰⁰

Work is also underway on the development of a new type of strategic nuclear-powered submarine, and these submarines will join the strategic forces represented today by submarines in the Project 667 BDRM - Delta-IV and Project 941 - Typhoon classes, perhaps one day replacing them. The class is known as Project 935. The Project 935 submarines will probably be half the size of the Typhoon submarines and will be equipped with 20 SLBM missiles.¹⁰¹ There is no information confirming that this class of vessels will actually be built.¹⁰² The Project 935 vessels may well be the fifth generation of Russian nuclear-powered submarines, and they will, if constructed, enter service in 2015 at the earliest.¹⁰³

2.2.5 Nuclear-powered submarines with liquid metal cooled reactors.

Right after the Soviet Union's first nuclear-powered submarine was put in operation in the summer 1958, preparations were made for the construction of Project 645 class K-27, a submarine powered by two liquid metal cooled reactors (lead bismuth).¹⁰⁴ This vessel was designed by SKB-143 in St. Petersburg and was built at

the Severodvinsk shipyard. Due to demands from the Supreme Soviet for rapid construction, the submarine was built using the already developed hull of the Project 627A-November class submarines. According to the Soviet designers, the advantages of the liquid metal cooled reactors is that less electrical power is needed for start up and shut down. Subsequently, the capacity of the batteries in K-27 was only a fourth of that in the submarines with pressurised water reactors. The submarine was also equipped with automatic turbo generators.¹⁰⁵ The K-27 suffered a series of accidents with its nuclear reactors, but remained in operation until the occurrence of a major accident with the reactors in 1968. In 1981, the entire vessel was dumped in the Kara Sea, near Novaya Zemlya.¹⁰⁶

The experiences from the Project 645 submarine class formed the basis for a series of seven Project 705 and 705 K-Alfa class submarines. All were equipped with liquid metal cooled reactors, and they were smaller and faster than all of the preceding submarine types.¹⁰⁷ The Alfa class submarines were noisy and easy to detect, but superior in speed so that in battle, they would probably be able to outrun the torpedoes aimed at them. The principal task of the Alfa class submarines was to destroy the enemy's strategic submarines. Today, only one of these vessels, K-123, remains in operation.¹⁰⁸

2.2.6 Prototype submarines

The Soviet Union has built five prototype submarines. The Project 645 class submarine (K-27) was the first and is described above. The next one was Project 661 - Papa class (K-162), a submarine developed in answer to a resolution of the Ministry of Defence and the Supreme Soviet to construct a fast nuclear submarine for the purposes of research. This submarine was powered by a new type of reactor, and had a hull built of titanium.¹⁰⁹ Project planning for the new submarine began in 1960 under the direction of chief designer N. N. Isain. It became operative in December 1969, and has the highest registered underwater speed for submarines at 44.7 knots.¹¹⁰ The advantage of a titanium hull is that it becomes stronger, and can better endure the increased

95 Pavlov, A.S., *Military Vessels in the Soviet Union and Russia 1945-1995*. 1994.

96 *Jane's Defence Weekly*, No. 11, September 16, 1995.

97 Office of Naval Intelligence, *Worldwide Submarine Proliferation in the Coming Decade*, (3rd edition), May 1995.

98 *Jane's Defence Weekly*, November 4, 1995.

99 *Jane's Defence Weekly*, No. 11, November 16, 1995.

100 Lee, R. *State of the Russian Navy data page*, latest update, January 9, 1996.

101 *Ibid*

102 *Jane's Fighting Ships 1995-1996*, 98th edition.

103 *Jane's Defence Weekly*, No. 9, February 28, 1996.

104 Mormul, N., Note, 1995.

105 *Severny Rabochoy*, March 3, 1994.

106 Yablokov, A. V., *Facts and problems related to radioactive waste disposals in seas adjacent to the territory of the Russian Federation*, Moscow 1993.

107 Burov, V. N., *Otechestvennoye voyennoye Korablestroyeniye*, St. Petersburg, 1995.

108 *Jane's Defence Weekly*, November 4, 1995.

109 Osipenko, L., Shiltsov, L., and Mormul, N., *Atomnaya Podvodnaya Epopeya*, 1994.

110 *Krasnaya Zvezda*, May 27, 1995.

Number of nuclear- powered submarines built in the USSR/Russia in the period 1958-1995

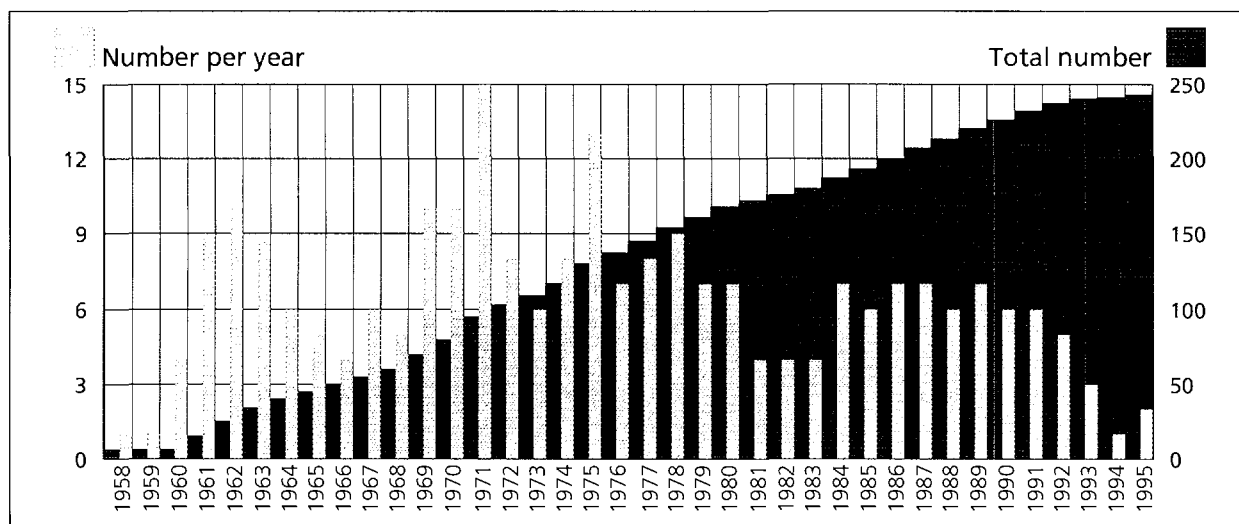

pressure at great depths while at the same time increasing its speed. Later, two series of nuclear submarines were constructed with titanium hulls: the Project 705 - Alfa class and the Project 945 - Sierra class.¹¹¹ Today there are no submarines being built with titanium hulls, presumably because these hulls are very expensive.¹¹²

The next prototype was the ill-fated Project 685 - Mike class submarine K-278 *Komsomolets*.¹¹³ This vessel was also built with a titanium hull, and was the world's deepest diving nuclear submarine, with a registered diving depth of 1 022 metres.¹¹⁴ *Komsomolets* sank in the Norwegian Sea in April 1989.

In addition to the prototype nuclear submarines, the Soviet Union also developed a nuclear reactor which by simple means could be installed into a diesel-driven submarine. The reactor carries the classification Nurka class, and today is located at Olenya naval base in Ara Bay. The diesel submarines in the Northern Fleet are the Project 940 - India class, Project 641-B - Tango class and Project 887 - Kilo class.¹¹⁵ but it is not known into which of the diesel-powered submarine classes the Nurka reactors can be installed.¹¹⁶

2.2.7 Mini submarines

The Soviet Union has also developed three classes of mini submarines, all of which belong to the Northern

Fleet. The mini submarines are as follows: one submarine of Project 10831 class, one of Project 1851 - X-ray class and three submarines of Project 1910 - Uniform class. Mini submarines are equipped with one pressurised water reactor each,¹¹⁷ and are probably used for special missions. They do not carry nuclear weapons.¹¹⁸

2.2.8 Nuclear-powered surface vessels

Since 1974 three nuclear powered battleships, Project 1144 - Kirov class, have been built and taken into service,¹¹⁹ namely the *Admiral Ushakov*, the *Admiral Lazarev* and the *Admiral Nakhimov*. In the latter half of 1995, a fourth one, the *Pyotr Veliky*, was tested at the shipyard in St. Petersburg, and is expected to become operational in 1996.¹²⁰ This ship will be transferred to the Northern Fleet.¹²¹

A nuclear-powered communication ship, Project 1941 - Kapusta class (SSV-33 *Ural*), was based with the Pacific Fleet, but was later laid up because it was too complex for the Navy to operate.¹²²

The main problem with nuclear powered battle cruisers is the lack of properly equipped naval bases and facilities for servicing the reactors. In addition to the problem of reactor maintenance, the ships' diesel motors are worn out.¹²³ Hence, virtually none of these ships are operative, and are therefore laid up.¹²⁴ Secondly, anot-

111 Mormul, N., Note, 1995.

112 *Na Strazhe Zapolyarya*, April 22, 1995.

113 *Morskoy sbornik*, No. 4, 1994.

114 *Na Strazhe Zapolyarya*, April 22, 1995 and *Morskoy sbornik*, No. 4, 1994.

115 *Jane's Fighting Ships* 1995-96, 98th edition.

116 Information from the Ukrainian Ministry of Defence, 1994.

117 *Ibid.*

118 The Norwegian periodical *Vårt Vern*, No. 3, 1993

119 Pavlov, A.S., *Military Vessels in the Soviet Union and Russia 1945-1995*, 1994.

120 *Na Strazhe Zapolyarya*, April 22 1995 and *Krasnaya Zvezda*, October 13 1995.

121 *Krasnaya Zvezda*, October 13, 1995.

122 Pavlov, A.S., *Military Vessels in the Soviet Union and Russia 1945-1995*, 1994.

123 Handler, J., Greenpeace, *Radioactive Waste Situation in the Russian Pacific Fleet, Nuclear Disposal Problems, Submarine Decommissioning, Submarine Safety, and Security of Naval Fuel*, p. 35, October 27, 1994.

124 *Morskoy sbornik*, No. 6 -1993.

Table 4. Number of nuclear powered vessels built in the Soviet Union/Russia in the period 1958-1995.

Project	Nato Class	No. built	Reactors	Total reactors in class	Number operative in the Northern Fleet	Reactors operative in the Northern Fleet
1st generation						
627 A	November	13	2 (PWR)	26	0	0
658	Hotel	8	2 (PWR)	16	0	0
659	Echo I	5	2 (PWR)	10	0	0
675	Echo II	29	2 (PWR)	58	0	0
2nd generation						
667 A	Yankee	34	2 (PWR)	68	0	0
667 B - BDRM	Delta I-IV	43	2 (PWR)	86	18	36
670	Charlie I-II	17	1 (PWR)	17	0	0
671 /RT/RTM	Victor I-III	48	2 (PWR)	96	18	36
3rd generation						
941	Typhoon	6	2 (PWR)	12	6	12
949 /A/	Oscar I-II	12	2 (PWR)	24	8	16
945	Sierra	4	1 (PWR)	4	4	4
971	Akula	12	1 (PWR)	12	5	5
LMR						
645	ZhMT	1	2 (LMR)	2	0	0
705	Alfa	7	1 (LMR)	7	1	1
Prototype						
661	Papa	1	2 (PWR)	2	0	0
685	Mike	1	1 (PWR)	1	0	0
Mini submarines						
10831		1	1 (PWR)	1	1	1
1851	X-ray	1	1 (PWR)	1	1	1
1910	Uniform	3	1 (PWR)	3	3	3
Surface vessels						
1144	Kirov	4	2 (PWR)	8	2 (3)	4 (6)
1941	Ural	1	2 (PWR)	2	0	0
Total		247		456	67	119

her serious drawback is the lack of naval base facilities for refuelling the reactors.¹²⁵ Again, this reflects the problems described in Chapter 1 in that the construction of the necessary supporting naval bases and shipyards have not kept pace with the development of nuclear powered naval vessels.

2.3 Development of naval reactors

Parallel to the development and launching of four generations of nuclear submarines has been the development of four generations of naval nuclear reactors. Furthermore, prototype reactors have been developed for use in

the submarines of Project 645 ZhTS class (K-27) and Project 661 - Papa class along with the submarines of Project 10831, Project 1851 - X-ray class and Project 1910 - Uniform class. A liquid metal cooled reactor has been put into serial production. There are minor differences in the construction of the reactors within each reactor generation as well as within each class of submarines. For example, both the OK-350 reactor found in submarines of the Project 670 - Charlie class and the reactor type OK-300 installed in Project 671 - Victor class submarines, are considered second generation submarine reactors.

A principal difference between submarine reactors and the reactors found in conventional nuclear power plants is in the size and power in proportion to volume.

The uranium fuel used in civilian nuclear power plants mainly has an enrichment of four percent ²³⁵U.¹²⁶

¹²⁵ Ibid.

¹²⁶ Nilsen, T., and Bøhmer, N., *Sources to Radioactive Contamination in Murmansk and Arkhangelsk Counties*, Bellona Report no.1 :1994. Chapter 5 - *The Kola Nuclear Power Plant*

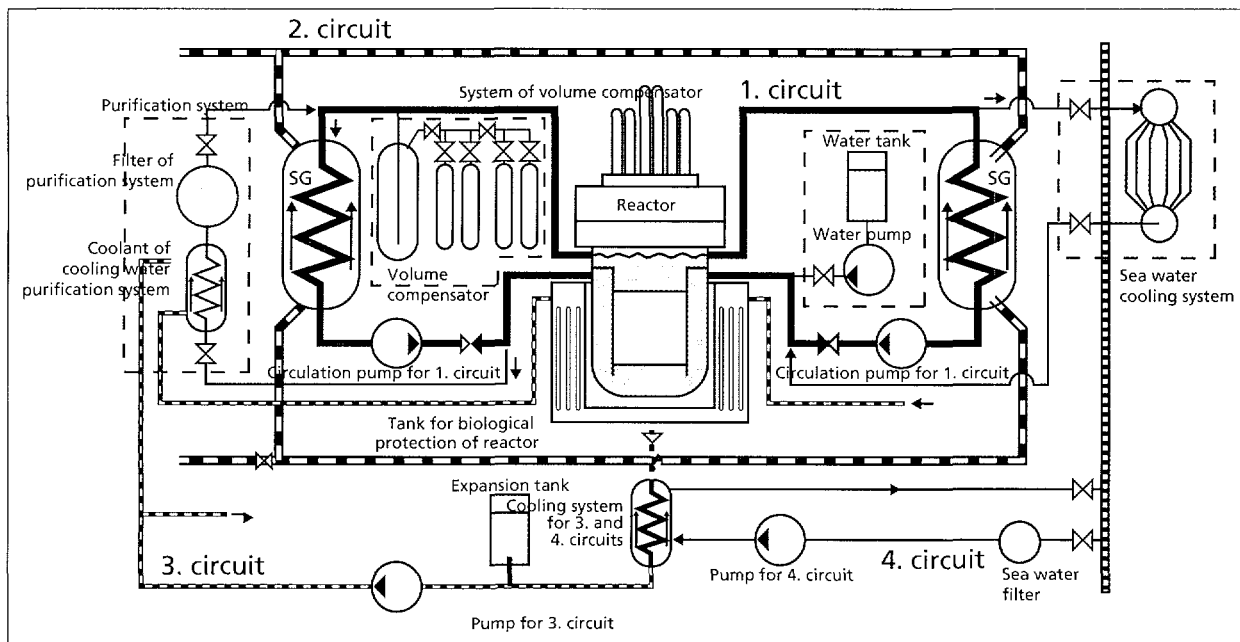

The drawing shows a reactor of the first generation of Soviet nuclear submarines

The enrichment is considerably higher in submarines. In Russian vessels, enrichment can be as much as 90 percent¹²⁷ so that submarines can go for longer periods between refuelling the reactors.

The thermal power of Russian submarine reactors varies from 10 MWt for the smaller reactors used in the Project 1910 - Uniform class submarines, to 200 MWt for the reactors used in the new Project 885 - Severodvinsk class submarine. The nuclear powered surface vessels, Project 1144 - Kirov class, have reactors with a thermal power of 300 MWt.

In the descriptions of naval reactors, the technical defects of the various reactors are emphasised, especially those that have led to accidents and an ensuing leak of radioactivity. It is important to keep this section in context with Chapter 8 to gain a complete picture of accidents involving Russian submarines.

2.3.1 First generation reactors

Several design and construction bureau's, manufacturers and corporations in the former Soviet Union have been involved with the construction of nuclear powered vessels. In 1952, the construction of the first nuclear powered submarine began, and it became necessary to solve a whole new series of engineering problems. For example, one of the main tasks was to construct the submarines' nuclear reactor, along with the various systems and mechanisms that would ensure its running without pro-

blems. Scientific director for some of the earliest work was academy member A. P. Aleksandrov, while principal builder of the nuclear reactor was academy member N. A. Dollezal.¹²⁸

The decision was made to develop a pressurised water reactor to power the first nuclear submarine. This reactor was the first of its kind in the Soviet Union, for the construction of pressurised water reactors for use in land based nuclear power stations did not begin until 1955. During the development of naval pressurised water reactors, a whole new range of important problems arose, in which experience from the existing graphite moderated reactors offered no answers. (Graphite moderated reactors were built in the Soviet Union in order to produce plutonium for nuclear weapons).

Thus the first set of problems to be solved was as follows:¹²⁹

- Optimal cooling of the nuclear reactor;
- Methods of regulating the neutrons;
- Methods for describing neutron behaviour in a pressurised water reactor;
- High burnup of nuclear fuel and accumulation of fission products from ^{235}U .
- Development of heat transfer models for the nuclear reactor.
- Development of automatic control procedures for nuclear reactors.

In order to solve these problems, a small nuclear reactor that could be used in a submarine was built. Later,

127 Office of Technology Assessment, *Nuclear Waste in the Arctic, an Analysis of Arctic and Other Regional Impacts from Soviet Nuclear Contamination*, September 1995.

128 *Morskoy sbornik*, No. 1 - 1995.

129 The items below are listed in *Atomnaya Energiya*, Vol. 73, No.4 - 1992.

four generations of such reactors with a series of modifications were constructed on the basis of this reactor.¹³⁰

The construction of nuclear reactors for use in submarines was at that time a major technological achievement. However, from a radiation safety point of view, the reactors suffered from a number of serious flaws. These flaws resulted in a number of accidents, of varying degrees of severity. During the active life of the first generation submarines, there were five accidents in which the reactor was irreparably damaged. These were as follows (listed by the name of the submarine and the year of the accident): K-19 in 1961, K-11 in 1965, K-222 in 1980, K-431 in 1985 and K-192 (formerly K-131) in 1989. In addition, a first generation liquid metal cooled reactor on board the submarine K-27 broke down in 1968. Besides this, there have been two near critical accidents involving K-19 in 1961 and K-116 in 1979. There have also been 18 accidents involving first generation reactors that have resulted in releases of radioactivity. The first generation reactors were produced from 1957 to 1968.¹³¹

Flaws in first generation reactors:¹³²

- Large volume and distribution of space in the primary circuit. Pipes connecting the reactor with steam generators, pumps, heat exchangers, volume compensatory devices etc., were too large in diameter. This caused major problems in protection against leakage in the primary circuit (see breakdown of the K-129 submarine), and easily caused wear of small pipes connecting monitoring instruments to the primary circuits. These were often ruined and became the cause of leaks (see accident involving the K-19 submarine).
- Poor reliability of heavy equipment, and in particular, the electric devices located in and around the nuclear reactor. Much of this equipment was not designed to endure large variations in temperature levels and pressure. The temperature in the primary circuits was approximately 300 °C, the steam had a temperature of 250 °C and the pressure level was approximately 200 atmospheres.
- Operational problems in the automation of the reactor control processes.
- Poor reliability of data from monitoring instruments was a problem for the operating personnel. The reliability of reactor control and protection systems was also poor (see breakdown of the K-222 submarine).
- The third safety barrier was underestimated. Calculations later proved that the third safety barrier would lose its airtight qualities in the event of a breach in the

primary circuit. This would result in the radioactive contamination of the reactor compartment. (see breakdown of the K-192 submarine).¹³³

- Insufficient system for the control of chain reactions in the reactor core - safety of the system questionable. Starting equipment can control nuclear processes in the reactor during start up only at minimum power. Before, the nuclear reactor was started up according to a special program calculated by the operating personnel. In some instances this program could be wrong.¹³⁴
- A lack of space around the lid of the reactor increased the danger of the lid being opened without the operators maintaining full control of the process. This, together with overloading of equipment and possible failure to follow procedures by the operating personnel, could lead to over pressure in the reactor core followed by an explosion (see accidents with K-431 and K-222 in 1980).¹³⁵ The cooling circuits in first and second generation nuclear submarines are such that reactor accidents resulting in explosions due to over pressure cannot occur because under all operating conditions, there will always be a certain amount of coolant in the reactor core.

There are a number of other flaws in the first generation reactors, especially in equipment that could lead to minor releases within the reactor compartment. Releases to the surrounding environment are eliminated by the submarine hull.

Today, all of the first generation submarines have been taken out of service and are awaiting decommissioning. (see table).¹³⁶ The ecological problems associated with these vessels are related to defuelling, deactivation of reactor equipment and the storing of radioactive equipment taken from the vessels.¹³⁷ Extra precautions must be taken when defuelling submarines containing damaged nuclear fuel. This is especially true of the submarine K-192 which in 1989 suffered a meltdown in one of its reactors. (See Chapter 6 on the decommissioning of nuclear submarines).

Another important point is that the first generation reactors were operated by self-taught crews who did not have the same sense of radiation safety as has become common in the operation of nuclear reactors today (see account of the accident involving the submarine K-19).¹³⁸ The lack of concern for radiation safety at that time was owing largely to the lack of experience in operating nuclear reactors in submarines.

130 Ibid.

131 Nilsen, T., and Böhmer, N., *Sources to Radioactive Contamination in Murmansk and Arkhangelsk Counties*. Bellona Report no.1 :1994.

132 Unless otherwise stated, this information is from Bakhmetyev, A. M., *Methods of judging safety levels and securing nuclear energy generators*, 1992

133 *Sudostroenie*, No. 11-12, 1992.

134 Alyeshin, V. S., *Vessel Nuclear Reactors*.

135 *Atomnaya Energiya*, No. 4 - 1993.

136 *Nezavisimaya Gazeta*, April 22, 1995

137 *Krasnaya Zvezda*, July 13, 1995.

138 *Atomnaya Energiya*, No. 2 - 1994.

During the last years of operation of the first generation of nuclear submarines, the vessels were staffed by officers and quartermasters who for various reasons could not work on the newer vessels.¹³⁹ This is also true of the vessels that have been taken out of service but not yet defuelled, and it affects the safety of laid up vessels waiting to be decommissioned.

2.3.2 Second generation reactors

As stated earlier, the second generation submarines (Project 667 Yankee and Delta class, Project 670 - Charlie class and 671 - Victor class) were developed and built from 1967 onwards. The first submarine with a second generation naval reactor came to the Northern Fleet in the second half of 1967.¹⁴⁰ Construction of the Project 667, the largest series of Soviet submarines, came to a stop in 1990.

The second generation reactors were developed based on the experiences gained from operating the former generation of reactors. Design flaws in the first generation reactors were taken into consideration and remedied. However, the consciousness of radiation safety was still in its infancy in the Soviet Union. The world had not yet seen the accidents of Three Mile Island (1979) and Chernobyl (1986).

Nor had any one anticipated reactor accidents entailing a loss of coolant. Leaks in the heat transfer pipes within the reactor were thought to be the worst conceivable problem that could arise. Therefore, only a limited number of safety standards were instituted to prevent loss of coolant in the reactor and thereby secure the safety of the submarine.¹⁴¹

Experience from the first generation reactors showed that the main operational problem was leakage of water from the primary to the secondary circuit. This occurred mainly through the steam generators. There were also problems of leaks in the pumping systems and the gaskets of the steam generators. The pumps and steam generators were intended to cool the reactor in the event of a power failure.

These experiences formed the basis for modifications introduced in the second generation reactors. Nevertheless, the loop pattern (i.e., a system of spiralling cooling pipes) was retained. The volume and distribution of the primary circuit was sharply reduced, and a system of pipes within pipes was used for the steam generators, especially for the newest pumps leading to the primary circuit.

The number of wide diameter pipes used in connec-

ting some of the central components of the reactor (filter of the primary circuit, volume compensators and so forth) was also reduced. Practically all of the pipes (both large and small) were placed with biological shielding in the uninhabited parts of the submarine. The monitoring systems and the automatic control systems were also modified substantially. Remote control equipment became more common. In the second generation submarines, alternating current replaced the direct current used in the submarines of the first generation, and this change made it possible to reduce the size of some of the equipment. Finally, the turbine-generator was automated.¹⁴²

Despite the changes, there were still safety problems in the operation of the second generation nuclear reactors. From 1967 to the present, there have been three major accidents involving these pressurised water reactors, on the submarines K-140 in 1968, K-320 in 1970 and K-314 in 1983. There also have been several minor incidents of leakage in the second generation reactors.¹⁴³ A very basic flaw in the second generation reactors was the poor quality of equipment used in the reactor core, steam generators and automatic equipment.

Reactor accidents are principally caused by cracks in the fuel assemblies with the ensuing leakage of water from the primary circuit to other cooling circuits via the steam generators. The poor quality of the equipment has caused accidents because of uncontrolled starting up of the reactor, as was the case in an accident involving the submarine K-146. There have also been problems of the automatic systems failing to function properly.

Other unsolved problems include:¹⁴⁴

- Cooling of the nuclear reactor at complete power failure in the submarine;
- Control of nuclear processes in the reactor during near-critical conditions (except some submarines in which an auxiliary start up system has been installed during repairs).
- Loss of coolant in the reactor core in the event of a break in the primary circuit.

Towards the end of the 1970s came a growing awareness of safety. In that spirit, regulations for radiation safety were set that went beyond the government's own interests. General rules concerning safety (FBS, OPB (FBS-73) and OPB (FBS-82)) were established as well as safety rules and guidelines for nuclear reactors in which recommendations from MAGATE were taken into account. (These are abbreviations for Russian safety control authorities and safety regulations which are not easily translated into English).

139 *Morskoy sbornik*, No. 6 - 1993.

140 *Krasnaya Zvezda*, April 29., 1995.

141 *Atomnaya Energiya*, No. 2 and 4 - 1994.

142 *Atomnaya Energiya*, No. 4 - 1993.

143 Nilsen, T., and Bøhmer, N., *Sources to Radioactive Contamination in Murmansk and Arkhangelsk Counties*. Bellona Report no.1 :1994 and Osipenko, L., Shiltsov, L., and Mormul, N., *Atomnaya Podvodnaya Epopeya*, 1994.

144 Kremlin, A. E., *Security at Nuclear Energy Installations and Sarkisov, A. A., Physical Basis for the Use of Nuclear Steam Producing Installations* and *Atomnaya Energiya*, No. 4 - 1993.

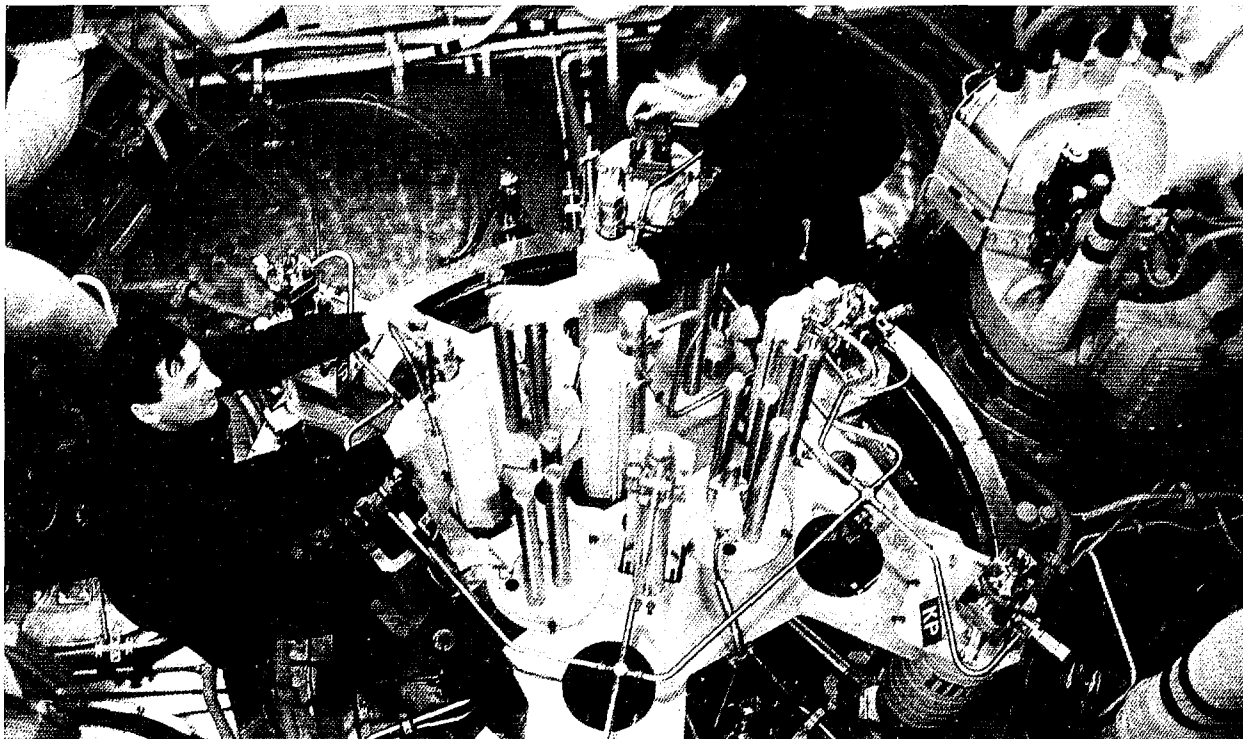

Maintenance at one of the reactors in a Typhoon submarine. These reactors are of 3. generation, with improved safety systems. Even though the reactors deliver a thermal effect on 190 MW, they are small in size

2.3.3 Third generation reactors

Development on the third generation nuclear reactors began in the early 1970s, and it is these reactors that power submarines in the Project 941 - Typhoon class, 949 - Oscar class, 945 Sierra class and 971 Akula class. Henceforth reactors would be constructed with the intent of minimising the likelihood of accidents and breakdowns. New safety systems were developed, especially to ensure the cooling of the reactor core in emergency situations. New instruments and monitoring equipment were developed that would rapidly pinpoint problems inside the reactor. These systems were developed in order to handle many different types of leaks in the pipe systems at any time. This was especially important with respect to potential leakage in cooling pipes that were large in diameter.¹⁴⁵

A new block system was developed to protect the cooling circuits from leakage. By replacing the old system of pipes with a block system, in which the reactor and the cooling system were treated as one block, the dimensions of the pipes and other components could be reduced because the cooling efficiency of the system could be increased.

From a safety point of view, this solved number of problems. First of all, this system permitted a natural

circulation of coolant within the primary circuit, even at high power. This was important for the flow of coolant into the reactor core at complete or partial power failure. With the block system, pipes to the primary circuit were replaced with short, wide diameter pipes which connected the main components (reactor, steam generators, and pumps).¹⁴⁶ The reactors were equipped with a cooling system which operated independently of the batteries and that started up automatically in the event of a power failure.

The control and shielding system of the reactor was altered extensively. Emergency start equipment gave the possibility of controlling the state of the reactor at any level of power, even in near-critical situations. An automatic mechanism was installed on some of the control rods which in the event of power failure, would lower the reactor lid to its lowest level, thus completely halting the reactors. This would also occur should the submarine capsize. A number of other technical improvements contributing to increased safety were also introduced.¹⁴⁷

The main safety problems of the third generation reactors were problems with the main components, especially the reactor core, and keeping them properly cooled during operation. The numerous mechanical processes

¹⁴⁵ *Atomnaya Energiya*, No. 4 1996.

¹⁴⁶ *Atomnaya Energiya*, No.4 -1993 and No. 6 1994.

¹⁴⁷ *Ibid.*

increased the likelihood of operational problems. The safety systems were designed in a way such that mechanical parts or cooling pipes would burst before the reactor was irreparably damaged. This made it easier to locate damages and implement repair before it was too late.¹⁴⁸

2.3.4 Fourth generation reactors

At the present time, none of the fourth generation submarines have come into service, but plans call for the completion of several Project 885 - Severodvinsk class vessels. The first will probably be ready in 1998.¹⁴⁹ The reactor for the first submarine was finished in 1995. Fourth generation nuclear reactors are formed into a single block. The monoblock design has the advantages of localising the coolant in the primary circuit into one volume of fluid and eliminates the need for pipes of wide diameter. The fourth generation reactors are constructed consistent with modern requirements for radiation safety. Due to the awkwardness of access to the reactor's mechanical parts, remotely controlled equipment is necessary, both during operation and partly during maintenance and repairs.¹⁵⁰

2.3.5 Liquid metal cooled reactors

The liquid metal cooled reactor (AIFMV) is a special category of nuclear reactors. A series of submarines using liquid metal cooled reactors have been built (Project 705 - Alfa class). The first submarine to have a liquid metal cooled reactor was a Project 627 ZhTS class vessel, K - 27). The reactor of this submarine was severely damaged after a pipe in the reactor compartment was contaminated by corrosion particles from the liquid metal (a lead bismuth compound). Subsequently, one of the nuclear reactors overheated.¹⁵¹

On the initiative of Admiral G. Gorshkov (former chief admiral of the Navy), a series of seven submarines of Project 705 - Alfa class were constructed. The first Alfa class submarine, under the command of A.S. Pushkin, experienced a number of problems and small accidents during its sea trials and the short experimental period. It was finally dismantled after a series of large cracks occurred in the reactor compartment. The reactor along with its spent nuclear fuel was filled with furfurool and bitumen, and is now at the Zvezdochka Shipyard in Severodvinsk. The remaining six submarines of this class were in operation for 10 years.¹⁵² The submarines of the Alfa class as a whole had a total operational life of approximately 70 years.¹⁵³

The advantages of the liquid metal cooled reactor lay in its dynamics which provided greater power from reactors that were more compact than the traditional pressurised water reactor. The main electrical system was designed to operate at a frequency of 400 hertz, which in turn permitted a reduction in size of some of the reactor equipment. On the other hand, the operation of the reactor became more complex. Nuclear reactors with lead-bismuth cooling systems were developed by *Gidropress* and by the *OKBM* design bureau in Nizhny Novgorod.¹⁵⁴

The operation of liquid metal cooled reactors was complicated. The main problem was that the metal mixture solidified if the temperature fell below 125°C, and if this happened, the reactor could be damaged. At Zapadnaya Litsa, the base of the Project 705 - Alfa class submarines, a special land-based complex was built for the support of these submarines. A special boiler room to provide steam to the submarines was built in order to prevent the liquid metal from solidifying when the reactors were turned off. In addition to this, a destroyer and floating barracks supplied steam from their own boilers to the submarines at the piers. Due to the inherent dangers of using these external sources of heat, the submarine reactors were usually kept running, albeit at low power.

The high degree of automation was a further cause of operational problems with these submarines. Only two of the compartments were habitable. All systems and equipment were controlled from a control panel in the command centre. Since the submarines were designed to be as compact as possible, the crew on the Alfa class vessels was considerably smaller than that on other types of Russian submarines (30 as opposed to 100).¹⁵⁵

Despite the occurrence of two accidents on submarines with liquid metal cooled reactors, these reactors are considered to be safer than the pressurised water reactors, for reasons related to qualities of the liquid metal coolant and the design of the reactor:¹⁵⁶

- High boiling point of the metal mixture (approximately 1680°C) with low pressure in the primary circuit, ruling out over pressure leading to an explosion in the reactor and the ensuing release of radioactivity.
- Rapid solidification of the liquid metal mixture in the event of leakage. The melting point of the mixture is 125°C, thereby excluding the possibility of reactor damage and loss of coolant.
- Very little long-lived Alfa activity in the coolant.
- No release of ²¹⁰Po gas (half-life 138 days).
- Qualities of the reactor in the event of fractures in the fuel cladding or leaks in the primary circuit. Rules out

148 Ibid.

149 *Jane's Fighting Ships* 1995 - 96, 98th edition.

150 *Atomnaya Energiya*, No. 1 - 1992 and No. 2 - 1984

151 *Vart Vern*, No 1 1993.

152 Pavlov, A. S., *Military Vessels of the Soviet Union and Russia 1945 - 1995*, 3rd edition, 1994.

153 *Atomnaya Energiya*, No. 1 - 1992 and No. 2 - 1992.

154 Ibid.

155 Burov, V. N., *Otechestvennoye voyennoye Korablestroyeniye*, St. Petersburg, 1995.

156 Ibid.

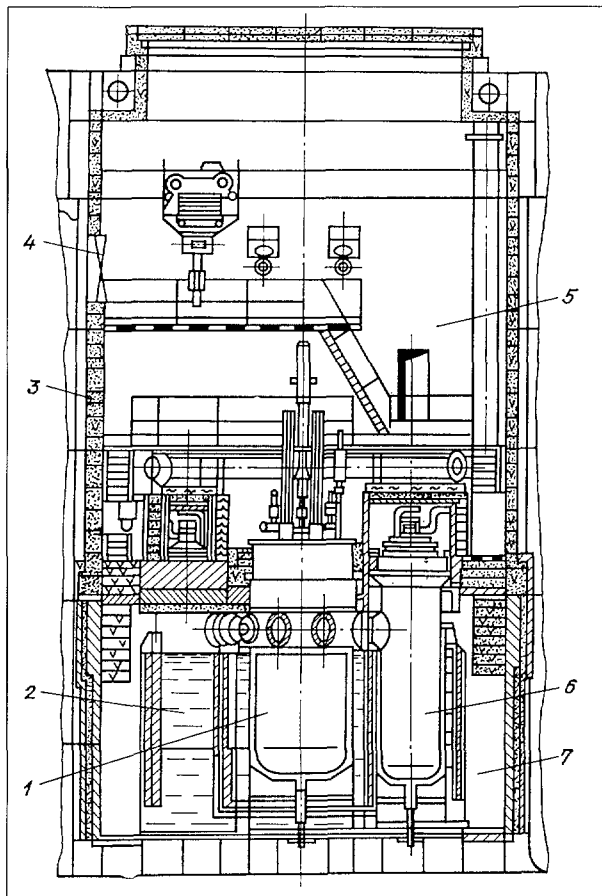

This is a cross-section of the reactor compartment in the civilian nuclear icebreaker *Arktika*. The reactor is a type KN-3 (OK-900) with a type VM-16 reactor core. This reactor is almost identical to the reactors used on board the nuclear powered battle cruisers.

- | | |
|-------------------|----------------------------|
| 1: Reactor | 2: (inner) protection tank |
| 3: (outer) shield | 4: emergency exit |
| 5: control room | 6: steam generator |
| 7: reactor room | |

significant releases of radioactive iodine, which constitutes the main danger to the crew.

- Small contents of radioactivity, which rules out uncontrolled start up of the reactor with prompt neutrons, as well as the possibility for automatic shut-down of the reactor in the event of accidents.
- The pressure immediately outside the primary circuit is higher than within this circuit, preventing the release of radioactive coolant.

The designers of the reactor have now solved the problems of "freezing" and "thawing" in the liquid metal mixture in the core, but submarines with liquid metal cooled reactors are no longer being built. The recently

repaired K-123, based at Zapadnaya Litsa, is the only one left in service.¹⁵⁷

2.3.6 Nuclear reactors on surface vessels

The nuclear reactors in use on Russian surface vessels were constructed drawing on experience gained from the building and operating of reactors for the nuclear icebreakers. The construction of the reactor is almost identical to that used in the nuclear icebreakers of the *Arktika* class. They have the classification KN-3 (OK-900) with a VM-16 type reactor core.

From the point of view of safety, the shortcomings in the construction of these reactors are the same as in the third generation submarine reactor,¹⁵⁸ although there are greater problems entailed with the installation of nuclear reactors on surface vessels than on submarines. This is because no solution has been found to the problem of building land bases with the necessary support equipment for these vessels. As a result, the reactors on board the *Admiral Ushakov* and *Admiral Nakhimov* were shut down for long periods, because the land base simply could not supply enough electrical power, steam and other necessities to keep them running. The components in these reactors were soon worn out, and there were no funds to implement repairs. The vessels were finally taken out of service.¹⁵⁹

The problem of refuelling the reactors on these ships is not yet solved. It was assumed this operation would take place at the *Sevmorput* shipyard in Murmansk, but the shipyard lacks the proper facilities to undertake such an operation. Subsequently the decision was made to transfer the work to the shipbuilding yards in Severodvinsk. This has not yet happened either, for the water in Severodvinsk is so shallow that it is difficult for the big battleships to come alongside quay. It is not expected that more nuclear powered surface vessels will be built after the fourth battleship *Pyotr Veliky* leaves the St. Petersburg shipbuilding yard, and is delivered to the Northern Fleet.¹⁶⁰

2.3.7 Russian submarine fuel

Fuel assemblies for Russian submarines with pressurised water reactors are produced at the machine building factory in Elektrostal outside Moscow. Fuel assemblies for the liquid metal cooled reactors on submarines of the Project 705-Alfa class and Project 645 ZhTS were produced at the Ulbinsky Metallurgical Works in Ust-Kamenogorsk in Kazakhstan.¹⁶¹

¹⁵⁷ Pavlov, A.S., *Military Vessels in the Soviet Union and Russia 1945-1995*, 1994.

¹⁵⁸ *Sudostroenie* (shipbuilding), No.9-1990 and No.1-1991.

¹⁵⁹ Handler, J., Greenpeace, *Radioactive Waste Situation in the Russian Pacific Fleet, Nuclear Waste Disposal Problems Submarine safety, and Security of Naval Fuel*, p.44, October 27, 1994.

¹⁶⁰ *Krasnaya Zvezda*, October 13, 1995.

¹⁶¹ Bukharin, O., and Handler, J., *Russian Nuclear-Powered Submarine Decommissioning*, 1995.

Table 5. Russian naval reactors; types, degree of enrichment and power.¹⁶⁴

Project/class	Number of degree of		Assumed (thermal power) enrichment (%)	Power of reactors MWt
	reactors	Type of reactors		
1st generation				
627 A-November	2	PWR, VM-A	21	70
658-Hotel	2	PWR, VM-A	21	70
659/675-Echo I-II	2	PWR, VM-A	21	70
2nd generation				
667 A-Yankee	2	PWR, OK-700, VM-4	21	90
667 B-BDRM-Delta I-IV	2	PWR, OK-700, VM-4-2	21	
670 A-Charlie I	1	PWR, OK-350, VM-4	21	90
670 M-Charlie II	1	PWR, OK-350, VM-4	21	75
671-Victor I-II	1	PWR, OK-300, VM-4	21	75
671-Victor III	2	PWR, OK-300, VM-4	21	75
3rd generation				
941-Typhoon	2	PWR, OK-650, W	21-45	190
949-Oscar I-II	2	PWR, OK-650 b	21-45	190
945-Sierra	1	PWR, OK-650	21-45	190
971-Akula	1	PWR, OK-650 b	21-45	190
Prototypes				
685-Mike	1	PWR, OK-650 b-3	21-45	190
661-Papa	2	PWR, VM-5 m	Unknown	177
1910-Uniform	1	PWR	Unknown	10
Liquid metal cooled				
645 ZhTS	2	LMR, VT-1	90	73
705-Alfa	1	LMR, OK-550, MB-40 A	90	155
Surface vessels				
1144-Kirov	2	PWR, OK-900 KN-3	Unknown	300
1941-Kapusta	2	PWR, OK-900 KN-3, VM-16	55-90	171

The reactor core in Russian nuclear-powered submarines consists of between 248 and 252 fuel assemblies, depending on the type of the reactor. Most Russian nuclear-powered submarines have two reactors. Each fuel assembly contains tens of fuel rods, and these vary from the traditional round rods to more advanced flat rods.¹⁶² The flat fuel rods are used particularly in the more recent generations of reactors. The point of the flat fuel rod is to enlarge the surface of each fuel rod so as to improve the thermal efficiency. Most of the uranium fuel assemblies are clad in steel or zirconium.¹⁶³

The enrichment of fuel in pressurised water reactors varies from 21% ²³⁵U in first generation reactors to 43-44% ²³⁵U in third generation reactors. The enrichment of the fuel assemblies stolen from a storage facility in Andreeva

Bay in 1993 was said to be 36%, and were suitable for insertion into third generation nuclear reactors. The fuel assemblies stolen from a storage facility in Rosta the same year were enriched to 28%,¹⁶⁵ and were suited for submarines of the Project 671 RTM-Victor-III class. The fuel of some pressurised-water reactors have even higher enrichment than this. The Project 1941 - Kapusta class nuclear powered communication ships of the Pacific Fleet have reactor cores with an enrichment of 55-90%. The enrichment of fuel in liquid metal cooled reactors can be as high as 90 percent ²³⁵U.¹⁶⁶ Some submarines have probably utilised fuel of a different enrichment than is standard for the reactor on an experimental basis.

The reactor cores of third generation nuclear powered submarines contain fuel assemblies of varying degrees of

¹⁶² Ibid.

¹⁶³ Nilsen, T., and Böhmer, N., *Sources to Radioactive Contamination in Murmansk and Arkhangelsk Counties*. Bellona Report no.1 :1994.

¹⁶⁴ Information collected from; Pavlov, A. S., *Military Vessels in the Soviet Union and Russia 1946-1995*, 1994.; Office of Technology Assessment, *Nuclear Waste in the Arctic, an Analysis of Arctic and Other Regional Impacts of Soviet Nuclear Contamination*, 1995; Bukharin, O., and Handler, J., 1995.

¹⁶⁵ *Moscow News*, No. 48, December 8-14, 1995.

¹⁶⁶ Bukharin, O., and Handler, J., *Russian Nuclear-Powered Submarine Decommissioning*, 1995.

enrichment. The fuel assemblies in the middle of the reactor core are enriched to 21% ^{235}U , while the outermost fuel assemblies are enriched as much as 45% ^{235}U . The reactors of third generation nuclear submarines contain approximately 115 kilograms of ^{235}U . The reactors on second generation submarines contain a total of approximately 350 kilograms of uranium, of which 70 kilograms are ^{235}U .¹⁶⁷ A standard reactor core of a first generation nuclear submarine has a total of approximately 250 kilograms of uranium, of which 50 kilograms are ^{235}U . These are also the quantities stated for each reactor dumped in the Kara Sea while still containing its nuclear fuel.¹⁶⁸

2.4 Radiation risks in naval reactors

For each reactor type, there is an almost identical list outlining the risk of nuclear accidents or dangers in radiation exposed work. These lists are derived in various radiation protection documents, and outline procedures with the highest risk of exposure to ionising radiation.

Nuclear accidents may be characterised in their entirety under the following criteria:

Start and progress of an uncontrolled chain reaction

Problems in cooling the reactor core

As a result of such an event, the crew could be exposed to higher than permitted doses of radiation or the fuel assemblies in the reactor could be damaged such that it can no longer be used.¹⁶⁹ Methods for preventing these kinds of situations are developed by the designers of the reactors, and the Navy is responsible for seeing that these rules are followed.

Included in the list of high risk operations are start up and shut down of the reactor, and routine procedures carried out while the reactor is running, such as taking hydraulic samples and water samples from the primary circuits. In addition, there is the risk of accidents during the monitoring of gases and the monitoring of functional and complex systems of control and safety.¹⁷⁰

Past experience indicates that the most high risk work is in refuelling the reactor,¹⁷¹ for the following reasons:

- The work is done by many different people with varying levels of qualification for the work at hand;
- Approximately 50 different technical operations are carried out during the process, 25 percent of which may potentially expose the operators to radiation.¹⁷²

The most dangerous situations during the removal of spent nuclear fuel are as follows:

- Disassembly and mounting of mechanisms for control and safety systems;
- Disassembly and mounting of the reactor lid;
- Removal and replacement of fuel assemblies;
- Refilling of primary circuits in the thermal system and testing of hydraulics;
- Connecting, adjusting and checking of safety devices;
- Manual checking for movement of the compensation register;
- Reactor start up, measurement of neutrons and thermal measurements and checking.

All of the above-mentioned operations are executed by personnel at the shipbuilding yards and on the floating bases (the Project 326 M and 2020-Malina class) for the reloading and transport of spent nuclear fuel. Start up of the reactor is carried out by personnel from the physics laboratory, trained at the Kurchatov Institute. The most dangerous technical operation is the removal of the reactor lid. Experience from earlier accidents during this very procedure, indicates that this operation can unleash a nuclear accident with a significant release of radioactivity to the water and air over a large geographical area.¹⁷³

In the 1990s, a safer method was developed for removing spent nuclear fuel from pressurised water reactors on submarines. First, the reactor tank is emptied of the water before the work begins. This water slows the neutrons inside the reactor. By removing the water from the tank, the risk of an uncontrolled chain reaction in the reactor core is reduced. The drawback with this method is that the level of radiation in the reactor compartment increases dramatically because there is no longer any water present to moderate the neutrons. Subsequently, extra measures must be taken to prevent the exposure of the workers to radiation. Hence this method of defuelling can only be carried out on submarines that have been laid up for a number of years whereby the level of radiation has decreased naturally.¹⁷⁴

The construction and start up of new nuclear-powered submarines also entails operations involving risks of radiation exposure, as is also the case when restarting a reactor which has been in for repair or modernisation.

The operations entailing a risk of exposure to radiation are primarily:¹⁷⁵

- Installing the uranium fuel into the reactor;
- Mounting and adjusting the control and safety systems of the reactor;
- Removing samples from the primary cooling circuit and the reactor core;
- Starting up the reactor, and the first trial of equipment.

167 Nilsen, T., and Böhmer, N., *Sources to Radioactive Contamination in Murmansk and Arkhangelsk Counties*. Bellona Report no.1 :1994.

168 Yablokov, A. V., *Facts and problems related to radioactive waste disposals in seas adjacent to the territory of the Russian Federation*, Moscow 1993.

169 *Regulations concerning nuclear and radiation safety on naval nuclear energy installations*.

170 Sarkisov, A. A., *Physical Basis for the Use of Nuclear Steam Producing Installations*, Moscow.

171 *Severny Rabochy*, June 3, 1993

172 *Handbook for the firm GRTsAS. Presented to the Russian Government*, Moscow, 1993.

173 *Atomnaya Energiya*, No.2-1994.

174 Information given on a pressconference in Severodvinsk, in connection with removal of spent nuclear fuel from the submarine with fabrication no. 401., march 1995.

175 *Handbook for the firm GRTsAS. Presented to the Russian Government*. Moscow, 1993.

Other related high-risk operations:

- Collection of radioactive waste during operation;
- Compression, sorting and burning of solid radioactive waste;
- Temporary storage and transport of radioactive waste;
- Deactivation of contaminated equipment and purification of radioactive gases.

Today, the start up of new naval reactors takes place at the shipyards in Severodvinsk. Newly refuelled reactors are started up at the shipyards on the Kola Peninsula or in Severodvinsk. Possible accidents will mainly contaminate the immediate surroundings near the nuclear submarine. Many of the shipbuilding yards are located close to densely populated areas. In Severodvinsk, there is an inhabited area only 400 metres away from the shipyard where operations involving hazards of radiation are carried out.

The risk of exposure to radiation during repair work, modernisation or the dismantling of inactive nuclear submarines, is two and a half times greater than during construction and normal operation of the submarines. This work generates four to five times more radioactive waste than during operation.¹⁷⁶ Accidents may occur during the removal and transport of the spent nuclear fuel from the reactors. The risk of accidents of criticality is great, for the containers of spent fuel assemblies may be damaged during reloading and transport. This could result in a release of radioactivity to the environment with the ensuing exposure to radiation of personnel and the civilian population.¹⁷⁷

Most of the naval shipyards on the Kola Peninsula and in Severodvinsk that undertake this work are located near fairly densely populated areas.

2.4.1 Radiation safety agencies for nuclear-powered submarines

A number of organisations within the Navy and the Ministry of Defence are responsible for monitoring the safety of the reactors on board nuclear submarines. None of them come under the authority of a civilian regulatory authority.

OPB (FBS)-73 delegated the responsibility for supervising nuclear installations to three government agencies. *Gosatomnadzor* (Radiation Protection Authority) in the Soviet Union was charged with the responsibility of monitoring compliance with safety regulations and standards, especially with regard to the strength of con-

structions and the use of equipment and pipelines. The national Committee for Nuclear Power ensured that regulations governing nuclear safety were followed. The Ministry of Health monitored radiation safety regulations and procedures, ensuring that these standards were followed. There were routine checks to ensure that the crew on board nuclear submarines were not being exposed to undue amounts of radiation. Monitoring of safety procedures at nuclear power plants was not independent, since all three of the regulatory authorities fell under the auspices of the Council of Ministers of the Soviet Union. The main task of the Federal Committee for Nuclear Power was to encourage the use of nuclear power. Later *Gosatomnadzor* was developed (now the Federal Department of Nuclear and Radiation Safety).

The Ministry of Defence, which until the middle of the 1980s was responsible for approximately 200 nuclear reactors was not answerable to any of above-mentioned committees or ministries. It was not until 1979 that a department for nuclear safety was established in the Ministry of Defence, answerable to the Commander in Chief of the Navy (not even the Minister of Defence). In charge of inspections was Vice-Admiral N. Z. Bisovka. The Ministry of Defence's nuclear reactors and the nuclear facilities and complexes supporting these reactors have still not been placed under a federal authority in Russia; nor are they open to international inspection by the IAEA.

Safety procedures for nuclear reactors were re-evaluated following the Chernobyl accident (including within the Ministry of Defence). This resulted in a decision whereby inspections of nuclear safety would be carried out by the Ministry of Defence.

All supervision and control over nuclear installations and issues of nuclear safety were thereby given to the Ministry of Defence at all stages, from project development to decommissioning. New regulations of nuclear safety (RAS) PBYa(RAS)-13.08-88 were developed for the reactors of the submarines. Design bureau's and construction yards analysed both operative nuclear reactors and those under construction and planning with regards to modern safety requirements. Regulation No.332 which required that nuclear projects under construction be brought up to safety standards consistent with regulations, was adopted. The regulation concerned first and foremost the third generation of nuclear submarines (which were then under construction) and the fourth generation of nuclear submarines (which were under design).

¹⁷⁶ *Ibid.*

¹⁷⁷ *Ibid.*

2.5 Classification of nuclear powered naval vessels

An overview of all nuclear powered submarines and surface ships in the Russian Navy is given in the following pages. Both the Russian project number and when possible, the classification name, are given, as well as the NATO classification of each respective class of submarines. Even though this report does not address conditions at the Russian Pacific Fleet, its submarines are included in the overview. This is because most of the Pacific Fleet's nuclear submarines

are also expected to be dismantled in Severodvinsk. The K-number indicates the military registration number of the vessel within the Navy. A number of the newer submarines also have names. Unless stated otherwise, information on reactor power (thermal), technical data, nuclear weapons, K-numbers and dates of construction are taken from the book *Military Vessels in the Soviet Union and Russia 1945-1995*.¹⁷⁸ The number of submarines as well as some technical information about the various classes of submarines is taken from *Jane's Fighting Ships 1995-96*. Other pieces of information on the various submarines is based on the material presented in the other chapters of this report.

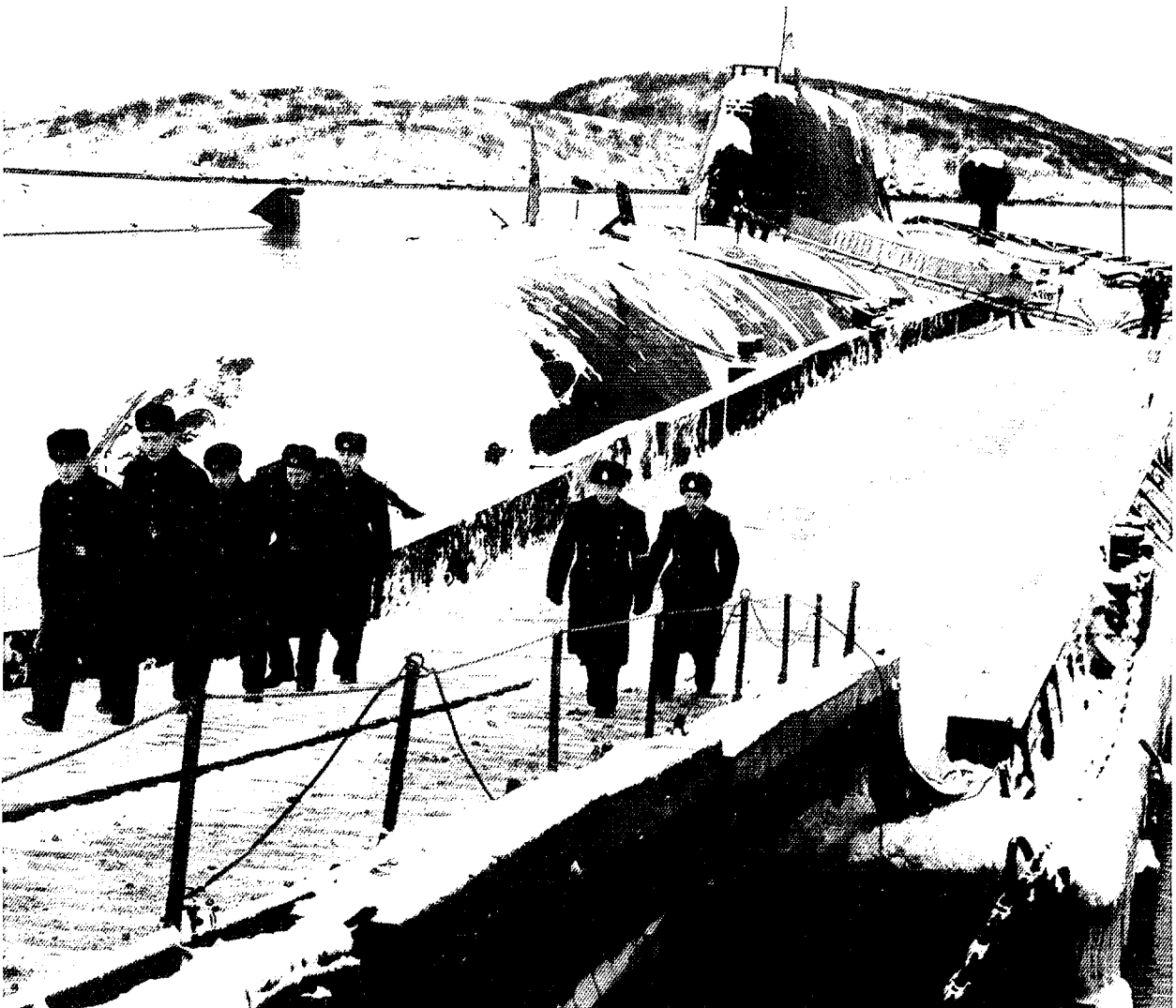

Alfa class submarine in the Ara Bay

178 Pavlov, A.S., *Military Vessels in the Soviet Union and Russia 1945-1995*, 1994.

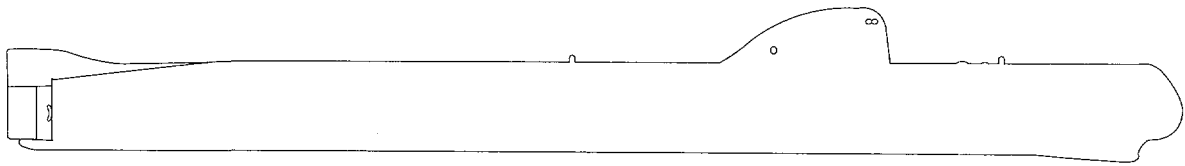

Project 627, 627 A (Kit) - November class

Number build: 13¹⁷⁹

	Northern Fleet	Pacific Fleet	Total
In service	0	0	0
Inactive	9	3	12
Dismantled	0	0	0
Sunk	1	0	1

Technical Data¹⁸⁰

Length: 107.4 m Displacement: 3 065/4.750 tons
 Beam: 7,9 m Hull: Low magnetic steel.
 Draught: 5.65 m Crew: 104 (30 officers)
 Speed: 28-30 knots Maximum Depth: 300 m.

Compartments: 9

- 1 - Torpedo room and accommodations
- 2 - Accumulator, accommodations and mess;
- 3 - Control room;
- 4 - Auxiliary machinery and diesel generator;
- 5 - Reactor compartment;
- 6 - Turbine compartment;
- 7 - Electro-technical and control centre for reactor;
- 8 - Auxiliary equipment;
- 9 - Steering system, accommodations.

Reactors:

Two pressurised water reactors, model VM-A, 2 x 70 MWt (2 x 17.500 hp). The reactors were running at 80% of their available power.

Individual Submarines

Northern Fleet:

K-3, *Leninskiy Komsomol*, factory no. 254, first nuclear powered submarine of the Soviet Union. Laid down on September 24, 1955, launched August 9, 1957, commissioned on July 1, 1958, sailed out to the White Sea on July 3. Ship's nuclear reactors started for the first time on July 4, 1958. K-3 was stationed at

Construction Yard:

Shipyards 402, Sever Machine Building Factory at Molotovsk (now known as Severodvinsk). The submarines were built in the period from September 1955 to December 1963.¹⁸²

Naval Architects¹⁸¹

Principal builder: Building and Construction Company SKB-143, V.N. Peregrudov.

Scientific Director: A.P. Aleksandrov.

Principal builder of

nuclear reactors: *Khimmash* Scientific Research, N.A. Dollezhyal.

Electrical

equipment: Elektrosila Institute, A.V. Mozalevskiy.

Radio electronics: NSh-49, N.A. Tsharin. Navigation equipment: MNII-1 Scientific Research Institute, E.I. Eller.

Hydroacoustics: Scientific Research Institute No. 3, E.I. Aldyshkin.

Air regeneration

system: GIPKh Company, V.S. Shpak.

Steel: Institute of Metallurgy and Welding, G.I. Kopyrin and V.A. Gorynin.

Naval Architects: UAGI Company, K.K. Fedayevskiy and UNII Scientific Research Institute, V.I. Pershin.

Nuclear Weapons: Scientific Research Institute-400, Mayak, A.M. Borushko.

Zapadnaya Litsa. The submarine's first commander was L.G. Osipenko.¹⁸³ On July 17, 1962, K-3 was the first Soviet submarine to reach the North Pole. The reactors were seriously damaged in June 1962 as a result of a fire and subsequent problems in the cooling system.¹⁸⁴ The submarine was towed to Severodvinsk where the decision was made not to deactivate the reactor. The reactor compartment of

¹⁷⁹ *Morskoy sbornik*, no. 1 - 1995.

¹⁸⁰ *Ibid.*

¹⁸¹ Mormul, N., Note, 1995.

¹⁸² Pavlov, A.S., *Military Vessels in the Soviet Union and Russia 1945-1995*, 1994.

¹⁸³ *Krasnaya Zvezda*, January 28, 1995, with reference to the magazine *Russkoe Oruzhiye* (Russian Weapons) which in turn refers to the book *Post-war History of the Soviet Navy (1945-1991)* by Rear Admiral Georgiy Kostev.

¹⁸⁴ *Komsomolskaya Pravda*, June 30, 1989.

the ship (No. 258) was therefore cut out and transported away to be dumped in Abrosimova Bay in the Kara Sea.¹⁸⁵ One of the reactors was dumped with its fuel. A new section with two reactors was then installed, but in 1967 another accident occurred affecting this section.¹⁸⁶ Today there are plans for the construction company Malakhit to turn K-3 into a museum.¹⁸⁷

- K-5,** factory no. 260. Commissioned on August 17, 1960. The Reactor compartment was cut out and replaced with two new reactors.
- K-8,** factory no. 261. Commissioned on August 31, 1960. Two months later on October 13, 1960, there was an accident involving the power generator with a leak of radioactivity outside Great Britain.¹⁸⁸ The submarine sank in the Bay of Biscay outside Spain on April 12, 1970 following a fire.
- K-11,** factory no. 285. Commissioned on December 23, 1961. During refuelling operations in Severodvinsk, an uncontrolled chain reaction occurred resulting in a fire on February 12, 1965.¹⁸⁹ The reactor compartment (either no. 254 or no. 260) was considerably damaged and had to be cut out of the submarine. Later that same year

or in 1966, both reactors were dumped into Abrosimova Bay in the Kara Sea while still containing their fuel,¹⁹⁰ and a new reactor compartment was installed.

- K-21,** factory no. 284. Commissioned on December 23, 1961.
- K-181,** factory no. 287. Commissioned on October 16, 1962.
- K-159,** Commissioned on November 4, 1963.
- K-50,** factory no. 290. Commissioned on December 20, 1963.
- K-52,** factory no. 283. Commissioned on December 23, 1963.

Pacific Fleet:

- K-14,** factory no. 262. Commissioned on December 31, 1959. The submarine belonged to the Northern Fleet until 1965 when it was transferred to the Pacific Fleet.
- K-42,** *Rostovsky Komsomolets*. Commissioned on November 4, 1963. Laid up in 1990.
- K-115,** factory no. 265. Commissioned on December 30, 1960. Originally assigned to the Northern Fleet; transferred to the Pacific Fleet in 1963.
- K-133,** Commissioned on October 16, 1962.

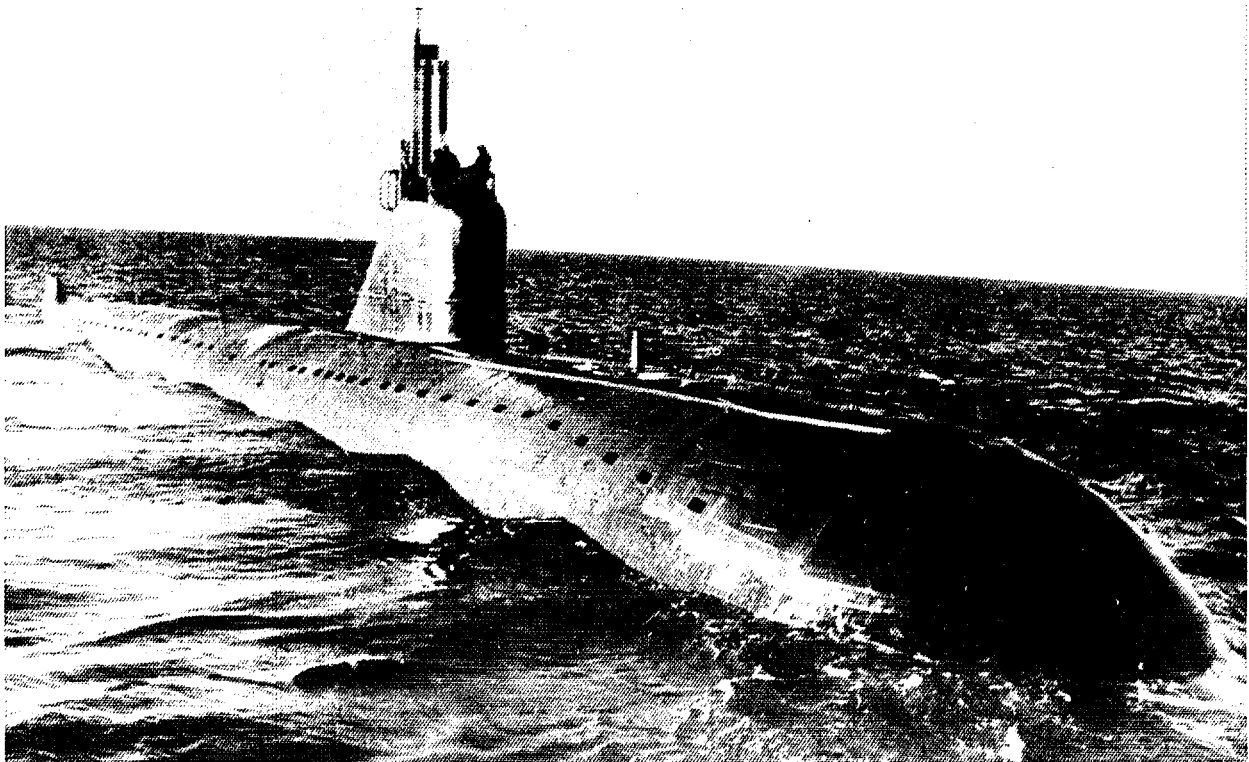

185 Yablokov, A. V., *Facts and problems related to radioactive waste disposals in seas adjacent to the territory of the Russian Federation*, Moscow 1993.

186 Osipenko, L., Zhiltsov, L., and Mormul, N., *Atomnaya Podvodnaya Epopeya*, 1994.

187 Mormul, N., Note, 1995.

188 Ølgaard, P.L., *Nuclear ship accidents: description and analysis*. 2nd Rev., Page 4. Department of Electrophysics, Technical University of Denmark, 1994.

189 Ibid.

190 Yablokov, A. V., *Facts and problems related to radioactive waste disposals in seas adjacent to the territory of the Russian Federation*, Moscow 1993.

Project 658, 658 M, 701 - Hotel Class

Number: 8

	Northern Fleet	Pacific Fleet	Total
In service	0	0	0
Inactive	6	2	8
Dismantled	0	0	0

Technical Data

Length: 114.1 m (127 m)	Displacement: 4 030/5 000 tons
Beam: 9.2 m	Maximum Depth: 300 m
Draught: 7.31 m (7.1 m)	Crew: 128
Speed: 26 knots	Hull: Low magnetic steel.

Compartments: 10

Reactors

Two pressurised water reactors, Model VM-A, 2 x 70 MWt (2 x 17 500 hp).

Naval Architect

Principal builder: S.N. Kovalev.

Construction Yard

The submarines were built at shipyard no. 402, Sevmash Machine Building Factory in Molotovsk (now Severodvinsk) in the period from 1958 to 1964. In the period between 1963 and 1967, the Northern Fleet's six Hotel class submarines were modified in Severodvinsk and D-4 type missile complexes were installed to carry R-21 missiles with a range of 1 400 km.¹⁹¹ The two Hotel class submarines belonging to the Pacific Fleet were rebuilt into torpedo submarines during the same period at the ship building yard Bolshoy Kamen in Shkotovo.

Bases:

The Hotel class submarines belonging to the Northern Fleet are now laid up in Oleniya Bay at naval shipyard no. 10 Shkval, at Gremikha and at the naval shipyard in Murmansk.¹⁹²

¹⁹¹ *Krasnaya Zvezda*, January 28, 1995, with reference to the magazine *Russkoe oruzhiye* (Russian Weapons) which in turn refers to the book *Post-War History of the Soviet Navy (1945-1991)* by Rear-Admiral Georgy Kostev.

¹⁹² Kværner Moss Technology a.s., *Disposal of Russian Nuclear Submarines*, January 19, 1996.

Individual Submarines

Northern Fleet:

- K-19**, factory no. 901. Laid down on October 17, 1958. Launched on April 8, 1959. Commissioned on November 12, 1960. On July 4, 1961, there was a reactor accident resulting in the removal and replacement of the reactor compartment (no. 901).¹⁹³ This work was carried out in Severodvinsk in the period from 1962 to 1964. The two damaged reactors with their fuel were dumped in Abrosimova Bay in the Kara Sea in 1965.¹⁹⁴ The submarine suffered a further reactor accident on February 24, 1972, in which 28 of the crew lost their lives.¹⁹⁵ After this accident, K-19 was rebuilt as a communications submarine. Because of her numerous accidents, K-19 received the nickname *Hiroshima*. The submarine was decommissioned in 1991 and is now based in Polyarny.¹⁹⁶
- K-33**, factory no. 902. Commissioned on July 5, 1961. Decommissioned sometime between 1988 and 1990.
- K-16**, factory no. 905. Commissioned on June 15, 1963. Decommissioned sometime between 1988 and 1990.

K-40, factory no. 904. Commissioned on December 28, 1962. From 1977, the submarine was used as a communications vessel with the ship's registration number KC-40. Decommissioned sometime between 1988 and 1990.

K-149 *Ukrainsky Komsomolets*, factory no. 907. Commissioned on February 12, 1964 and decommissioned sometime between 1988 and 1990.

K-145, factory no. 906. Commissioned on December 19, 1963. After a few years, the vessel was modified to carry six ballistic missiles. The submarine was decommissioned sometime between 1988 and 1990, and is now moored at the Sevmorput naval shipyard in Murmansk.¹⁹⁷

Pacific Fleet:

K-55, factory no. 903. Commissioned on August 12, 1962; now laid up in Pavlovsk.¹⁹⁸

K-178, factory no. 908. Commissioned on June 30, 1964 (?). At the North Pole for the first time on September 29, 1963. Now laid up in Pavlovsk.¹⁹⁹

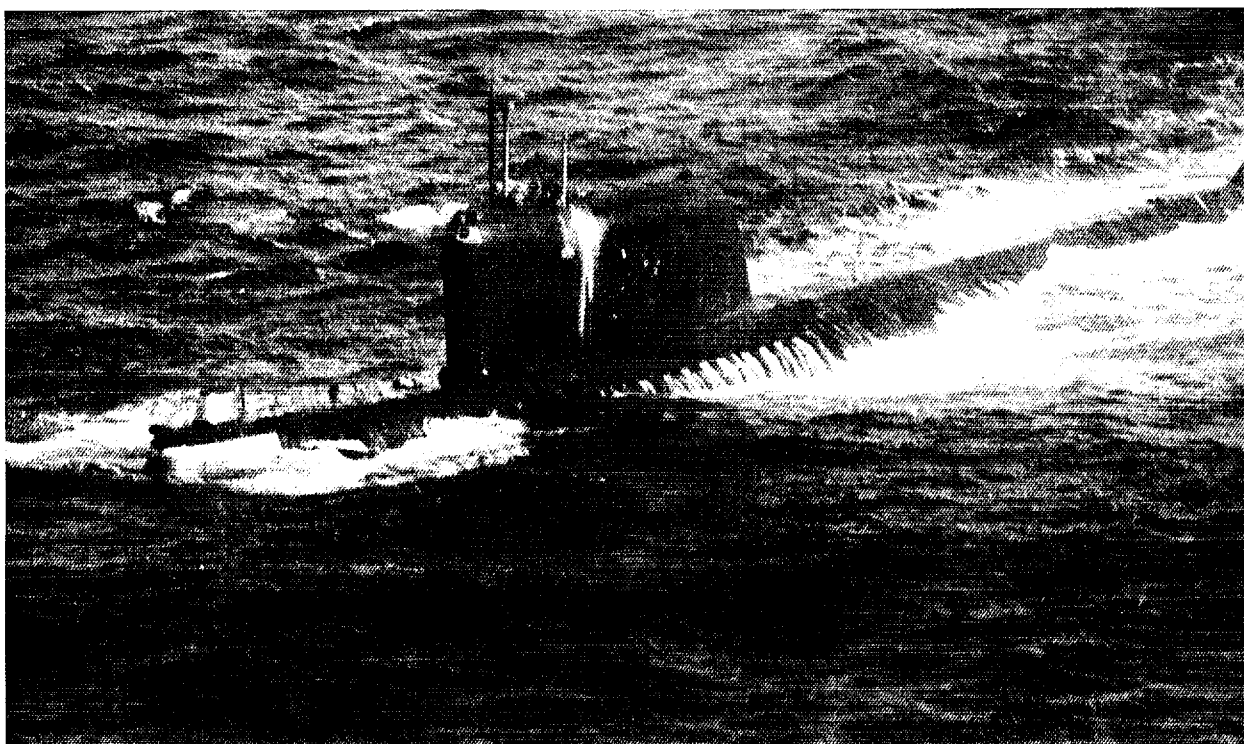

193 *Pravda*, July 1, 1991, and *Krasnaya Zvezda*, December 26, 1992.

194 Yablokov, A. V., *Facts and problems related to radioactive waste disposals in seas adjacent to the territory of the Russian Federation*, Moscow 1993.

195 Osipenko, L., Zhiltsov, L., and Mormul, N., *Atomnaya Podvodnaya Epopeya*, 1994.

196 Mormul, N. Notes, 1995.

197 *Ibid.*

198 Handler, Joshua, *Greenpeace, Radioactive Waste Situation in the Russian Pacific Fleet, Nuclear Waste Disposal Problems, SubmarineDecommissioning, Submarine Safety, and Security of Naval Fuel*, Page 44, Washington D.C., October 27, 1994.

199 *Ibid.*

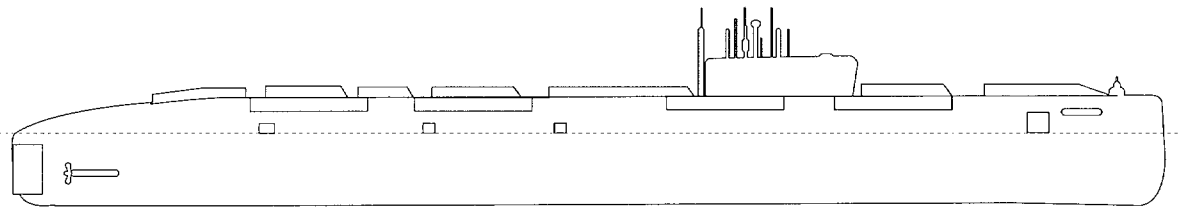

Project 659, 659 T Echo-I Class

Number: 5

	Northern Fleet	Pacific Fleet	Total
In service	0	0	0
Inactive	0	5	5
Dismantled	0	0	0

Technical Data

Length: 111.2 m Displacement: 3.731/4.920 tons
 Beam: 9.2 m Maximum Depth: 300 m
 Draught: 7.6 m Hull: low magnetic steel
 Speed: 29 knots Crew: 120

Reactor

Two pressurised water reactors, Model VM-A with a maximum power of 30 000 hp

Naval Architects:

P.P. Pustincev and N.A. Klimov.

Construction Yard

Komsomolsk-na-Amur.

Compartments: 9



Individual submarines

Pacific Fleet:

K-45. Laid down on December 28, 1957; vessel was launched on May 12, 1959 and commissioned by the Navy on September 18, 1960. In 1961 it was transferred as the first nuclear powered submarine of the Pacific Fleet under the command of Captain V.G. Delashev.²⁰⁰

K-59. Commissioned on December 10, 1961.

K-66. Commissioned on December 10, 1961. The submarine was taken out of service following an accident in 1980.

K-122. Commissioned on April 13, 1962. Inoperational following a fire on August 21, 1983.

K-259. Commissioned in December 1962.

²⁰⁰ *Krasnaya Zvezda*, January 28, 1995.

Project 675, 675 M, 675 MKV - Echo-II Class

Number: 29

	Northern Fleet	Pacific Fleet	Total
In service	0	0	0
Inactive	11	18	29
Dismantled	0	0	0

Technical Data

Length: 115.4 m	Displacement: 4 500/5 760 tons
Beam: 9.3 m	Maximum depth: 300 m
Draught: 7.1 m	Hull: low magnetic steel
Speed: 28 knots	Crew: 137

Compartments: 10²⁰¹

- 1: Torpedo room
- 2: Accumulators and officer's mess
- 3: Engineering and radio room
- 4: Reactor control room
- 5: Diesel generator and fresh water generator
- 6: Reactor compartment
- 7: Turbines
- 8: Electrical motor
- 9: Accommodations, kitchen
- 10: Torpedoes and steering systems

Reactor

Two pressurised water reactors, model VM-A with a capacity of 2 x 70 MWt (2 x 17 500 hp). The reactors ran at 100% power starting with submarine K-172.

Naval Architects:

P.P. Pustyntsev.

Construction Yard

Sever Machine Building Factory and Komsomolsk-na-Amur.

Individual submarines

Northern Fleet:

K-166, first registered as K-71. factory no. 530. This was the first Echo-II submarine to be built.

K-144, first registered as K-104, factory no. 531.

K-86, factory no. 532.

K-47, factory no. 534.

K-1, factory no. 535.

K-428, formerly registered as K-28, factory no. 536.

K-74, factory no. 537.

K-22, *Krasnogvardeets*, factory no. 538.

K-35, factory no. 539.

K-125, factory no. 542.

K-192, factory no. 533.²⁰² At present the submarine is moored at the naval shipyard Shkval in Polyarny with a severely damaged reactor following an accident on June 25-26, 1989.²⁰³ Pressurised air is pumped into the hull to keep the submarine afloat. The fuel in the undamaged reactor will be removed once the radiation has fallen to a safe level. There are also plans to remove the fuel from the damaged reactor.

Pacific Fleet:

K-127, registered until 1968 as K-7.

K-172 K-175 K-184 K-189 K-135 K-128

K-108 K-116 K-90 K-94 K-48

K-56. Was transferred to the Pacific Fleet on September 9, 1966. Suffered a reactor accident on June 13, 1973 in which 27 members of the crew died.

K-557, formerly registered as K-57.

K-431, formerly registered as K-31.

K-134, formerly registered as K-34 *Kefal*.

K-10 K-23

²⁰¹ Mormul, N, Note, 1995.

²⁰² *Problems with decommissioning of nuclear submarines and protection of the environment in the arctic areas.*, page 26-27, Severodvinsk, March 15.-16. 1995.

²⁰³ Yablokov, A. V., *Facts and problems related to radioactive waste disposals in seas adjacent to the territory of the Russian Federation*, Moscow 1993.

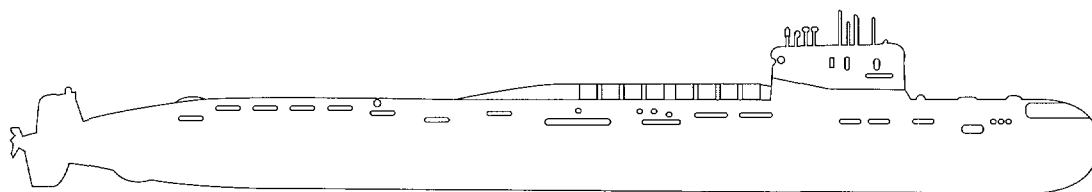

Project 667 A (Nalim, Navaga) - Yankee Class

Number: 34

	Northern Fleet	Pacific Fleet	Total
In service	1	0	1
Inactive	22	10	32
Dismantled	5	0	5
Sunk:	1	0	1

Technical Data

Length: 129.8 m Displacement: 7 766/9 300 tons
 Beam: 11.7 m Maximum depth: 400 m
 Draught: 8.7 m Hull: low magnetic steel
 Speed: 26 knots Crew: 120

Reactor

Two pressurised water reactors, model OK-700, with a VM-4 type reactor core. There is some variation amongst the reactors on board the various Yankee submarines. Power capacity is 2 x 90 MWt, with a shaft power of 2 x 20 000 hp.²⁰⁴

Naval Architects:

Rubin Shipbuilding Yard, Chief Builder S.N Kovalev.

Construction Yard

Of the 34 Yankee class submarines, 24 of them (Navaga) were built at Severodvinsk and the remaining 10 (Nalim) were built in Komsomolsk-na-Amur. All were built in the period from 1964 to 1972.

Nuclear Weapons

K-411 does not carry nuclear weapons, while K-420 carries twelve (12) Grom-750 missiles.

Base

The Yankee class submarine still in active service is based at Gadzhievo.

Comments

All of the Yankee class submarines except K-411 and K-420 were taken out of service and their missile compartments cut out to comply with the START II Treaty. Two of the submarines were taken out of service in 1979, two in January 1980, one in January 1981, two in January 1982, one in November 1982, one in June 1983, one in January 1984, two in April 1985, two in March 1986, two in 1987, and the rest in 1988 and 1989.

²⁰⁴ Pavlov, A.S., *Military Vessels in the Soviet Union and Russia 1945-1995*, 1994.

Individual Submarines

Northern Fleet (Navaga):

- K-137**, factory no. 420, *Leninets*. Laid down on November 9, 1964. Launched on August 28, 1966, and commissioned on November 5, 1967. The submarine will be decommissioned at the Zvezdochka shipyard.²⁰⁵
- K-140**, factory no. 421. Commissioned on December 30, 1967. Rebuilt after an accident that occurred on August 23, 1968, resulting in the removal of the reactor compartment (no. 421) and the installation of a new one.. The old reactor compartment was dumped into the Kara Sea in 1972.²⁰⁶ The missile section was refitted to carry 12 solid propellant missiles. Work has begun at Zvezdochka Shipyard in Severodvinsk to dismantle the submarine. The vessel was defuelled in the period May-June 1995, and the spent nuclear fuel will be transferred to the service ship PM-63.²⁰⁷ (See Chapter 3.2).
- K-32**, factory no. 423. Commissioned on October 26, 1968.
- K-26**, factory no. 422. Commissioned on September 3, 1968.
- K-216**, factory no. 424. Commissioned on December 27, 1968. The missile section was removed in Severodvinsk, and the vessel's hull with the reactors still inside was towed to Sayda Bay where it is moored to a pier.²⁰⁸
- K-207**, factory no. 400. Commissioned on December 30, 1968.
- K-210**, factory no.401. Commissioned on August 6, 1969. It is now awaiting dismantling in Severodvinsk. The reactor cover was removed on March 24, 1995, at 17:00 and the nuclear fuel transferred to the barge PM-124.²⁰⁹
- K-249**, factory no. 402. Commissioned on September 27, 1969.
- K-253**, factory no. 414. Commissioned on October 28, 1969.
- K-395**, factory no. 415. Commissioned on December 5, 1969.
- K-408**, factory no. 416. Commissioned on December 25, 1969.
- K-411**, factory no. 430. Commissioned on August 31, 1970. In 1979 it was rebuilt as Project 09780 to be able to carry two model KS-411 (Y STRECH) mini-submarines. This vessel remains in service.
- K-418**, factory no. 431. Commissioned on September 22, 1970. It was later rebuilt so as to be able to carry a different type of missile (Project 667 AR-Yankee Notch.)
- K-420**, factory no. 432. Commissioned on October 29, 1970. It was rebuilt in 1979-89 as part of Project 667 M (Andromeda) to be able to carry 12 Grom-P-750 missiles. These missiles can be launched from a submerged position, and are steered outside the submarine's pressure hull.

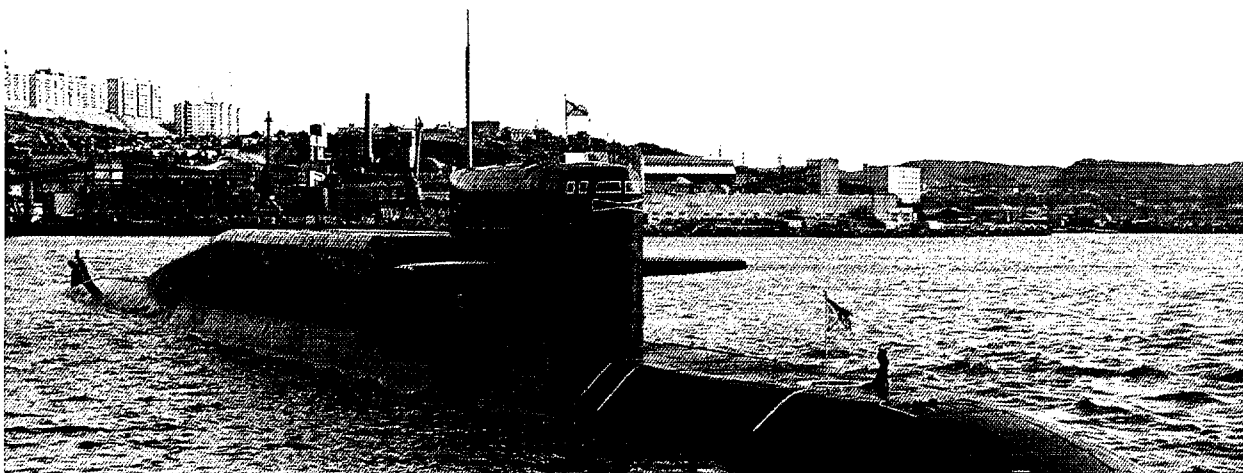

205 Document from the locale Gosatomnadzor (V. Dimitriev), environmental comitte of Severodvinsk (M. Mailov) and Controll Comitte for objects under the Minestry of Defence (A. Gordienko), 1995.

206 Nilsen, T., and Bøhmer, N., *Sources to Radioactive Contamination in Murmansk and Arkhangelsk Counties*. Bellona Report no.1 :1994.

207 *Problems with decommissioning of nuclear submarines and protection of the environment i the arctic areas.*, page 26-27, Severodvinsk, March 15.-16. 1995.

208 Ibid and visit to the Sayda Bay, Spring 1995.

209 Severny Rabochy, February 23. 1995 and information given on a press-conference in Severodvinsk March 24 1995.

- K-426**, factory no. 440. Commissioned on December 22, 1970.
- K-415**, factory no. 451. Commissioned on December 30, 1971. The submarine was dismantled in Severodvinsk²¹⁰ in 1994, and its reactor compartment and two other sections transported to Sayda Bay where they are moored at a pier.²¹¹
- K-403**, factory no. 441. Commissioned on August 20, 1971.
- K-423**, factory no. 442. Commissioned on November 13, 1971. Rebuilt later to carry a different type of missile (Project 667AR - Yankee Notch).²¹²
- K-245**, factory no.450. Commissioned on December 16, 1971.
- K-214**, factory no. 452. Commissioned on December 31, 1971.
- K-219**, factory no. 460. Commissioned on December 31, 1971. Sank on October 6, 1986.²¹³
- K-228**, factory no. 470. Commissioned on December 31, 1972. Dismantled at the Zvezdochka Shipyard in Severodvinsk.²¹⁴ The three compartments of the reactor compartment were towed to Sayda Bay in 1995.²¹⁵
- K-241**, factory no. 462. Commissioned on December 23, 1971. Dismantled in Severodvinsk; the three compartments of the reactor compartment were towed to Sayda Bay in 1994 and are now moored at a pier.²¹⁶
- K-444**, factory no. 461. Commissioned on December 9, 1972. In the summer of 1994, the submarine was at dock no. 10 at Zvezdochka Shipyard in Severodvinsk. Under existing plans, the three compartments of the reactor compartment will be towed to Sayda Bay.²¹⁷

Pacific Fleet (Nalin):

- K-399**. Commissioned on December 24, 1969.
- K-434**. Commissioned on October 21, 1970.
- K-236**. Commissioned on December 27, 1970.
- K-389**. Commissioned in 1970.
- K-252**. Commissioned in 1971.
- K-258**. Commissioned in 1971.
- K-446**. Commissioned in 1971.
- K-451**. Commissioned in 1971.
- K-436**. Commissioned in 1972.
- K-430**. Commissioned in 1972.

210 Document from the locale *Gosatomnadzor* (V. Dimitriev), environmental committee of Severodvinsk (M. Mailov) and Control Committee for objects under the Ministry of Defence (A. Gordienko), 1995.

211 Visit Sayda Bay, Spring 1995.

212 *Jane's Fighting Ships* 1995-96, 98th edition.

213 Ølgaard, P. L., *Nuclear ship accidents description and analysis*. 2nd. Rev., Department of electrophysics, Technical University of Denmark, 1994.

214 Decree 514, July 24, 1992, signed by J. Gaiydar.

215 Document from the locale *Gosatomnadzor* (V. Dimitriev), environmental committee of Severodvinsk (M. Mailov) and Control Committee for objects under the Ministry of Defence (A. Gordienko), 1995.

216 Visit Sayda Bay, Spring 1995.

217 Document from the locale *Gosatomnadzor* (V. Dimitriev), environmental committee of Severodvinsk (M. Mailov) and Control Committee for objects under the Ministry of Defence (A. Gordienko), 1995.



Project 667 B (Murena) - Delta-I Class

Number: 18

	Northern Fleet	Pacific Fleet	Total
In service	2	9	11
Inactive	7	0	7
Dismantled	0	0	0

Technical Data

Length: 139 m Displacement: 7 800/10 000 tons
 Beam: 11.7 m Maximum Depth: 550 m
 Draught: 8.4 m Hull: Low magnetic steel
 Speed: 26 knots Crew: 120

Reactor

Two pressurised water reactors, model OK-700 with a VM-4 type reactor core generating 2 x 90 MWt. Shaft power 2 x 20 000 hp. There are 250 fuel assemblies.

Individual Submarines

Northern Fleet:

- K-279**, factory no. 310. Laid down in 1971; launched in 1972 and commissioned to the Northern Fleet on December 22, 1972.²¹⁸
- K-447**, factory no. 311. Commissioned in 1973; still in use today.²¹⁹ The submarine was defuelled in 1994 and the spent fuel transferred to the service ship PM-63 in Severodvinsk.
- K-450**, factory no. 312. Commissioned in 1973.
- K-385**, factory no. 324. Commissioned in 1974.
- K-457**, factory no. 325. Commissioned in 1974. Still in service.²²⁰
- K-465**, factory no. 326. Commissioned in 1974.
- K-460**, factory no. 337. Commissioned in 1975.
- K-472**, factory no. 338. Commissioned in 1975.

Naval Architect

S.N. Kovalov, SKB-18.

Nuclear Weapons

Twelve (12) RSM-40/R-29 O type missiles (SS-N-12).

Construction Yard

Ten (10) Delta-I submarines were built at Severodvinsk in the period from 1971 to 1976. Another eight were built in Komsomolsk from 1974 to 1977.

Base

Gremikha.

Compartments: 10

Pacific Fleet:

- K-336**. Commissioned in 1974.
- K-417**. Commissioned in 1974.
- K-477**. Commissioned in 1975.
- K-497**. Commissioned in 1975.
- K-500**. Commissioned in 1976.
- K-512**. Commissioned in 1976.
- K-523**. Commissioned in 1977.
- K-530**. Commissioned in 1977.
- K-171**, factory no. 340. Commissioned in 1976; transferred from the Northern Fleet to the Pacific Fleet later in the same year.

²¹⁸ Kransya Zvezda, January 28. 1995.

²¹⁹ Mormul, N., Note, 1995.

²²⁰ Ibid.

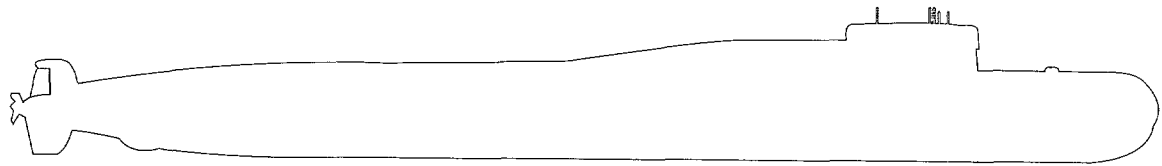

Project 667 BD (Murena M) - Delta-II

Number: 4

	Northern Fleet	Pacific Fleet	Total
In service	4	0	4
Inactive	0	0	0
Dismantled	0	0	0

Technical Data

Length: 155 m Displacement: 9 350/10 500 tons
 Beam: 11.7 m Maximum Depth: 550 m
 Draught: 8.6 m Hull: Low magnetic steel
 Speed: 25 knots Crew: 126

Compartments: 10

- 1 - torpedo room
- 2 - accommodations
- 3 - control room
- 4 and 5 - accommodations
- 6 - auxiliary machinery
- 7 - reactor compartment
- 8 and 9 - turbines
- 10 - electric motor and diving chamber

Reactor

Two pressurised water reactors, model OK-700 with a VM-4 type reactor core.

Nuclear Weapons

Sixteen (16) RSM-40/R-29 O type missiles.

Naval Architect

S.N. Kovalev.

Construction Yard

The Delta-II submarines were built in Severodvinsk from April 1973 to 1975.

Base

Gadzhievo.

Individual Submarines

K-182, factory no. 351. Laid down in April, 1973. Launched in January, 1975 and commissioned on September 30, 1975.

K-92, factory no. 352. Laid down in April, 1973. Launched in January, 1975 and commissioned on December 17, 1975.

K-193, factory no. 353. Laid down in 1974. Launched in 1975 and commissioned on December 30, 1975.

K-421, factory no. 354. Laid down in 1974. Launched in 1975 and commissioned on December 30, 1975.

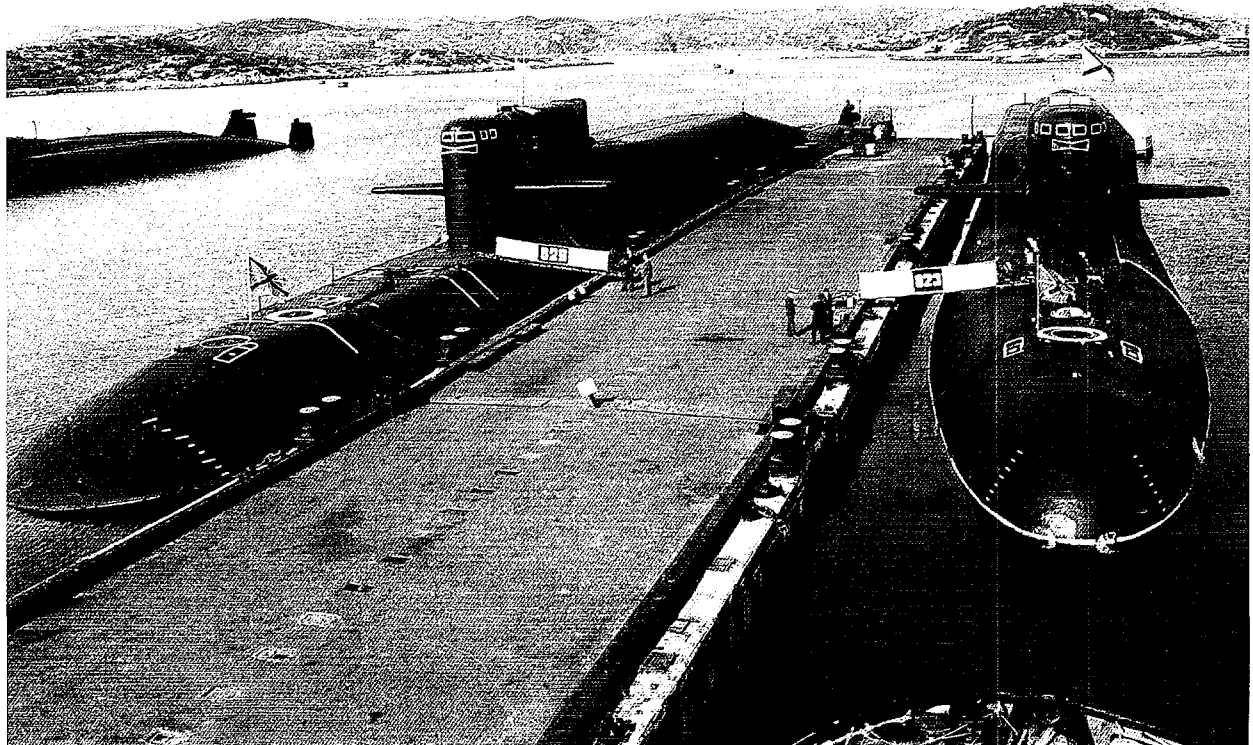

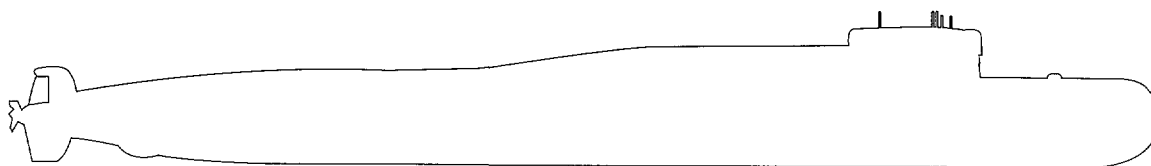

Project 667 BDR (Kalmar) - Delta-III Class

Number: 14

	Northern Fleet	Pacific Fleet	Total
In service	5	9	14
Inactive	0	0	0
Dismantled	0	0	0

Technical Data

Length: 155 m Displacement: 8 940/ 10 600 tons
 Beam: 11.7 m Hull: Low magnetic steel
 Draught: 8.7 m

Compartments: 11

Reactor

Two (2) pressurised water reactors, model OK-700; VM-4-2 type reactor core generating 2 x 90 MWt and a shaft power of 60 000 hp.

Nuclear Weapons

Sixteen (16) RSM-50 type missiles (SS-N-18).

Naval Architect

S.N. Kovalev.

Construction Yard

These submarines were built in Severodvinsk.

Base

The Delta-III submarines are based at Gadzhievo naval base.

Individual Submarines

- K-441.** Laid down in 1975. Launched in 1976 and commissioned in December 1976.
- K-424.** Commissioned in 1977.
- K-449.** Commissioned in 1977.
- K-455.** Commissioned in 1978.
- K-490.** Commissioned in 1978.
- K-487.** Commissioned in 1978.
- K-44.** Commissioned in 1979.
- K-496.** Commissioned in 1979.
- K-506.** Commissioned in 1979.
- K-211.** Commissioned in 1980.
- K-223.** Commissioned in 1980.
- K-180.** Commissioned in 1980.
- K-433.** Commissioned in 1981.
- K-129.** Commissioned in 1981.

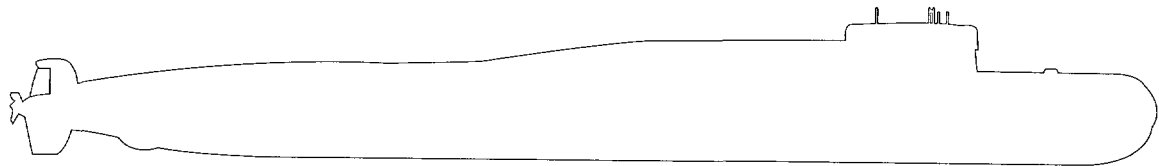

Project 667 BDRM (Delfin) - Delta IV Class

Number: 7

	Northern Fleet	Pacific Fleet	Total
In service	7	0	7
Inactive	0	0	0
Dismantled	0	0	0

Technical Data

Length: 167 m	Displacement: 9 210/11 740 tons
Beam: 12.2 m	Maximum Depth: 400 m
Draught: 8.8 m	Speed: 24 knots
Crew: 130	Hull: Low magnetic steel

Compartments: 10

Reactor

Two pressurised water reactors, model OK-700, with a VM-4 type reactor core generating 2 x 90 MWt.

Nuclear Weapons

Sixteen (16) RSM-54 type missiles (SS-N-23).

Naval Architect

S.N. Kovalev.

Construction Yard

The submarines were built in Severodvinsk from February 1981 to February 1992.

Base

All seven submarines of the Delta-IV class are stationed at the naval base Gadzhievo at Olenya Bay.

Individual Submarines

K-51. Laid down on February 23, 1981. Launched in January 1985 and commissioned by the navy on December 29, 1985.

K-84. Laid down in November 1984. The vessel was launched in December 1985 and commissioned in February 1986.

K-64. Laid down in November 1985. The vessel was launched in December 1986 and commissioned in February 1988.

K-114. Laid down in December 1986. The vessel was launched in September 1987 and commissioned in February 1989.

K-117. Laid down in September 1987. The vessel was launched in September 1985 and commissioned in March 1990.

K-18. Laid down in September 1988. The vessel was launched in November 1989 and commissioned in February 1991.

K-407. Laid down in November 1989. The vessel was launched in January 1991 and commissioned on 20 February, 1992.

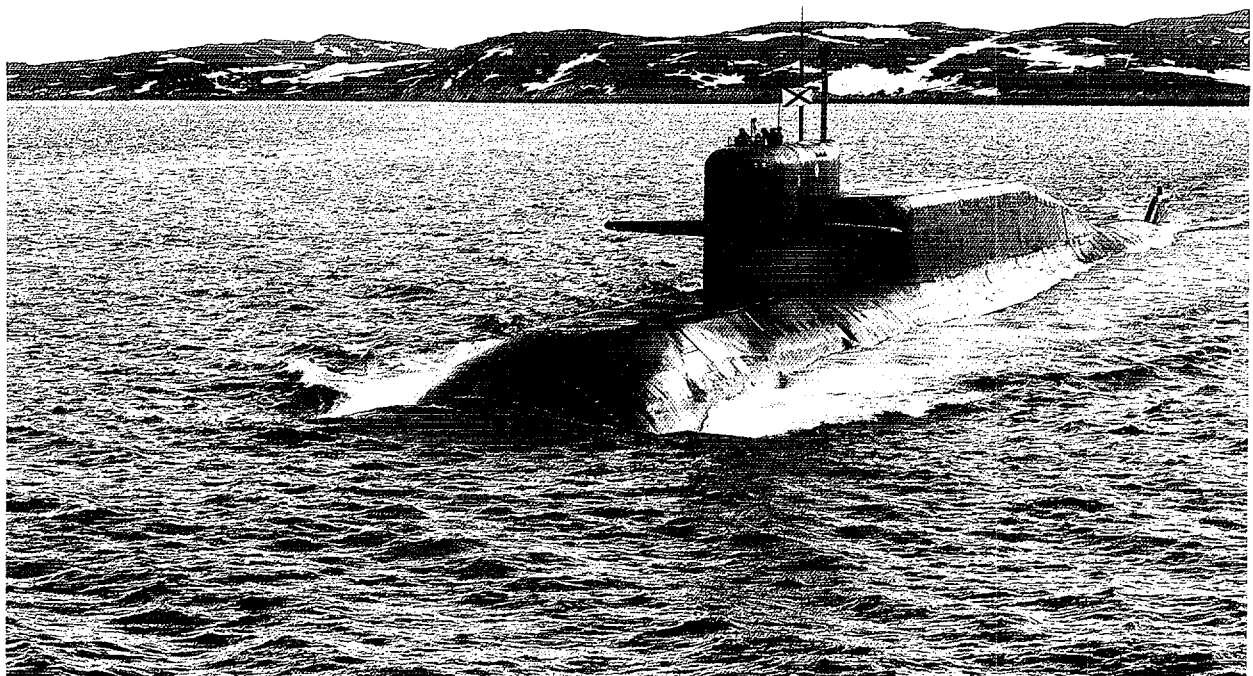

Project 670 A (Skat) - Charlie-I Class

Number: 11

	Northern Fleet	Pacific Fleet	Total
In service	0	8	8
Inactive	0	3	3
Dismantled	0	0	0

Technical Data

Length: 104 m	Displacement: 4 300/5 500 tons
Beam: 9.9 m	Maximum Depth: 300 m
Draught: 7.8 m	Hull: Low magnetic steel
Speed: 26 knots	Crew: 100

Compartments: 8

Reactor

A pressurised water reactor, model OK-350 with a VM-4 type reactor core generating 89.2 MWt (18 000 hp).

Naval Architects

I.M. Ioffe, V.P. Vorobyov, STB-112.

Construction Yard

Naval shipyard Krasnoye Sormovo in Gorky.

Individual submarines

Pacific Fleet:

K-43. From January 1988 until January 1991, K-43 was on loan to India. In India it was known as Chakra, Project 06709.

K-212. Until 1972, it was registered as vessel K-87.

K-25 K-121 K 313

K-308. Commissioned on September 20, 1970.

K-320. While the submarine was under construction at the shipyard in Gorky, an uncontrolled start up of the reactor occurred. This led to a leak of radioactive water.²²¹ The submarine was laid up as a reserve vessel in 1994.

K-302 K-325

K-429. The submarine sank at Kamchatka Peninsula on June 24, 1983. It was later salvaged and towed to a navy yard. It sank again at quay no. 13 on September 13, 1985. It was formally decommissioned in 1987.

K-201. The submarine was laid up in 1994 as a reserve vessel.

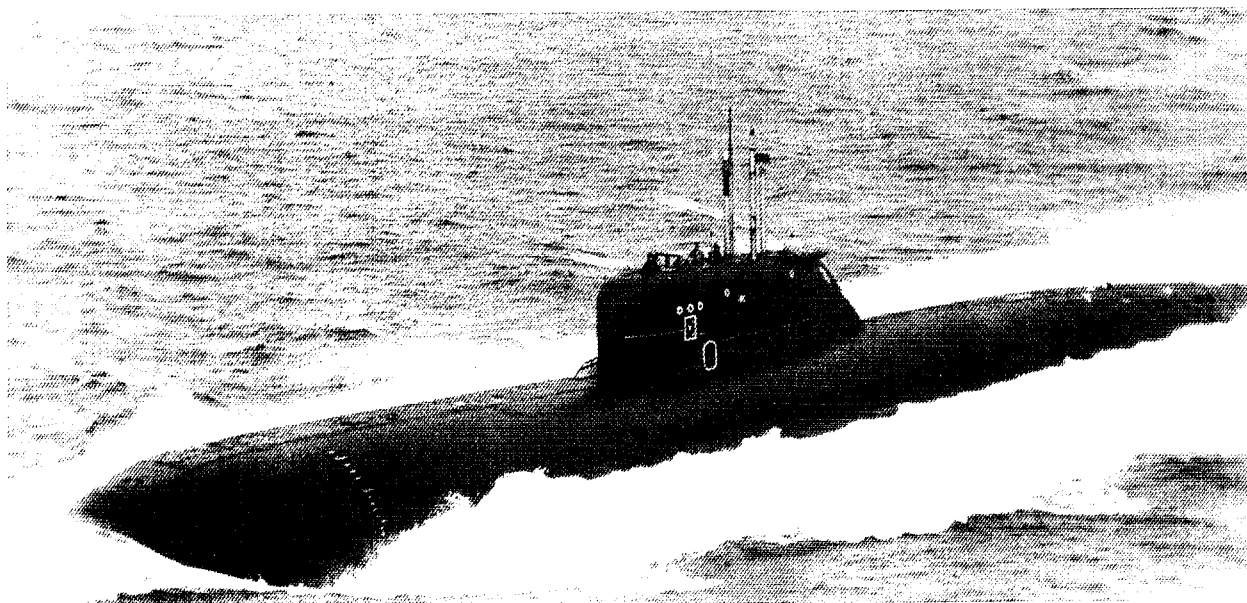

²²¹ Osipenko, L., Zhiltsov, L., and Mormul, N., *Atomnaya Podvodnaya Epopeya*, 1994.

Project 670 M (Skat M) - Charlie-II Class

Number: 6

	Northern Fleet	Pacific Fleet	Total
In service	3	0	3
Inactive	3	0	3
Dismantled	0	0	0

Technical Data

Length: 104.9 m Displacement: 4 372/5 500 tons
 Beam: 9.9 m Maximum Depth: 300 m
 Draught: 7.8 m Hull: Low magnetic steel
 Speed: 24 knots Crew: 98

Reactor

One pressurised water reactor, model OK-350, with a VM-4 type reactor core generating a power capacity of 2 75 MWt.

Nuclear Weapons

Naval Architects

Principal builder:

Construction Company-112, Lazurit, V.P. Vorobyev.

Construction Yard

The submarines were built from 1973 to 1980 at Krasnoye Sormovo shipyard.

Base

The Charlie-II submarines are based at Vidyayevo Naval Base in Ara Bay. A submarine has also been laid up at Ura Bay.²²²

Individual Submarines

K-452, factory no. 901. *Berkut..* Submarine still remains in operation.²²³

K-458, factory no. 902.

K-479, factory no. 903. Now at Nerpa Naval Yard where it will be dismantled.²²⁴ The submarine's fuel was removed in the spring of 1995.²²⁵

K-503, factory no. 904.

K-508, factory no. 905. Submarine remains in service.²²⁶

K-209, factory no. 911. Submarine remains in service.²²⁷

222 Kværner Moss Technology a.s., *Disposal of Russian Nuclear Submarines*, January 19, 1996.

223 Mormul, N., Note, 1995.

224 Decree no. 514 of the Russian Government signed by J. Gajdar, July 21, 1992.

225 The removal of fuel can be seen in the pictures taken by Rubny Murman.

226 Mormul, N., Note, 1995.

227 Ibid.

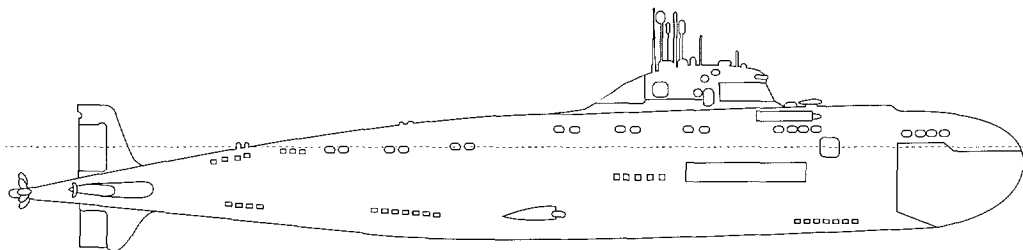

Project 671, 671 V, 671 K (Yersy) - Victor-I Class

Number: 15²²⁸

	Northern Fleet	Pacific Fleet	Total
In service	0	0	0
Inactive	13	2	15
Dismantled	1	0	1

Technical Data

Length: 94.3 m Displacement: 3 500/4 750 tons
 Beam: 10 m Maximum Diving Depth: 350 m
 Draught: 7.3 m Hull: Low magnetic steel
 Speed: 24 knots Crew: 94

Compartments: 7

- 1 - accommodations
- 2 - control room
- 3 - reactor compartment
- 4 - turbines
- 5 - auxiliary machinery
- 6 - accommodations
- 7 - electric-motor and steering

Individual Submarines

K-38, factory no. 600. Laid down in January 1965. Launched in October 1965 and commissioned on November 5, 1967.

B-369, formerly registered as K-69, factory no. 601.

K-147, factory no. 602. Remains in service.²²⁹

K-53, factory no. 603.

K-306, factory no. 604.

K-323, factory no. 605. The submarine is now moored in Severodvinsk where it is awaiting dismantling. It was scheduled to be defuelled in 1995.²³⁰

K-370, factory no. 606.

K-438, factory no. 608.

K-367, factory no. 609.

K-314, factory no. 610.

Reactor

One pressurised water reactor, model OK-300 with a VM-4 type reactor core generating 75 MWt (31 000 hp).

Naval Architects

Construction Company-16, Malakhit, G.N. Chernyshev.

Construction Yard

The Victor-I submarines were built at the Admiralty Shipyard in St. Petersburg from 1965 to 1974.

Base

Those submarines that have not yet been taken out of service are based at Gremikha.

K-398, factory no. 611

K-454, factory no. 612. Laid up in 1994 as a reserve submarine for the Pacific Fleet.²³¹

K-462, factory no. 613.

K-469, factory no. 614.

K-481, factory no. 615. The reactors were defuelled between November 1 and December 5, 1993, and their fuel transferred to PM-12, a service ship of the Project 2020 - Malina class. Today the submarine is partially dismantled and is moored at the Nerpa Naval Repair Yard.²³² Two floating pontoons will be mounted onto the reactor compartment which was scheduled to be towed to Sayda Bay for storage over the course of autumn 1995.

²²⁸ *Problems with decommissioning of nuclear submarines and protection of the environment in the arctic areas.*, page 26-27, Severodvinsk, March 15.-16. 1995.

²²⁹ Mormul, N., Note, 1995..

²³⁰ *Problems with decommissioning of nuclear submarines and protection of the environment in the arctic areas.*, Severodvinsk, March 15.-16. 1995.

²³¹ Pavlov, A. S., *Military Vessels in the Soviet Union and Russia 1945-1995*, 1994.

²³² Decree no. 514 of the Russian Government signed by J. Gaiydar, July 21, 1992.

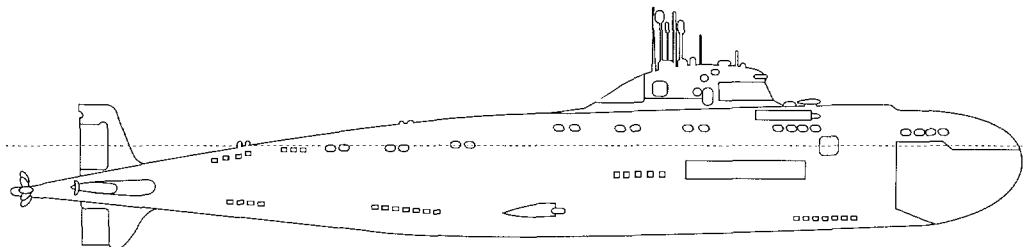

Project 671 RT Victor-II Class

Number: 7

	Northern Fleet	Pacific Fleet	Total
In service	2	0	5
Inactive	5	0	2
Dismantled	0	0	0

Technical Data

Length: 102 m Displacement: 4 245/5 800 tons
 Beam: 10 m Hull: Low magnetic steel
 Draught: 6.8 m Crew: 100
 Speed: 24 knots Maximum Depth: 350 m

Compartments: 8

- 1: Torpedo room and accumulators
- 2: Accommodations and mess
- 3: Control room
- 4: Reactor
- 5: Turbines
- 6: Turbo generators
- 7: Living accommodation and diesel generators
- 8: Steering system and electric motor

Reactor

Two pressurised water reactors, model OK-300, with a VM-4 type reactor core generating 75 MWt.

Naval Architects

Construction Company-16, Malakhit, G.N. Chernyshev.

Construction Yard

The Victor-II class submarines were built at the Admiralty Shipyard in St. Petersburg from 1967 to 1978.

Base

Submarines in active service are stationed at Bolshaya Lopatka.

Individual Submarines**Northern Fleet:**

K-387, factory no. 801. Commissioned on December 30, 1972.

K-371, factory no. 802. Commissioned in 1974. The vessel is now moored at the naval shipyard Shkval in Polyarny. Due to a lack of funds, necessary repairs and maintenance have not been carried out. The submarine has not been officially decommissioned, but it is not expected that it will actually be repaired. The naval yard's principal responsibility is to keep the vessel afloat and to ensure necessary fire safety precautions.

K-476, factory no. 803. Commissioned in 1975.

K-513, factory no. 625. Commissioned in 1977.

K-517, factory no. 627. Commissioned on October 28, 1978.

K-488, factory no. 804. Commissioned in 1976. The vessel is now moored at naval yard no. 10 Shkval in Polyarny. Extensive repairs are necessary, but there is no money earmarked expressly for this work. It is unclear what will be done with K-488, but it is likely that it will be removed from the active forces.

K-495, factory no. 621. Commissioned in 1976.

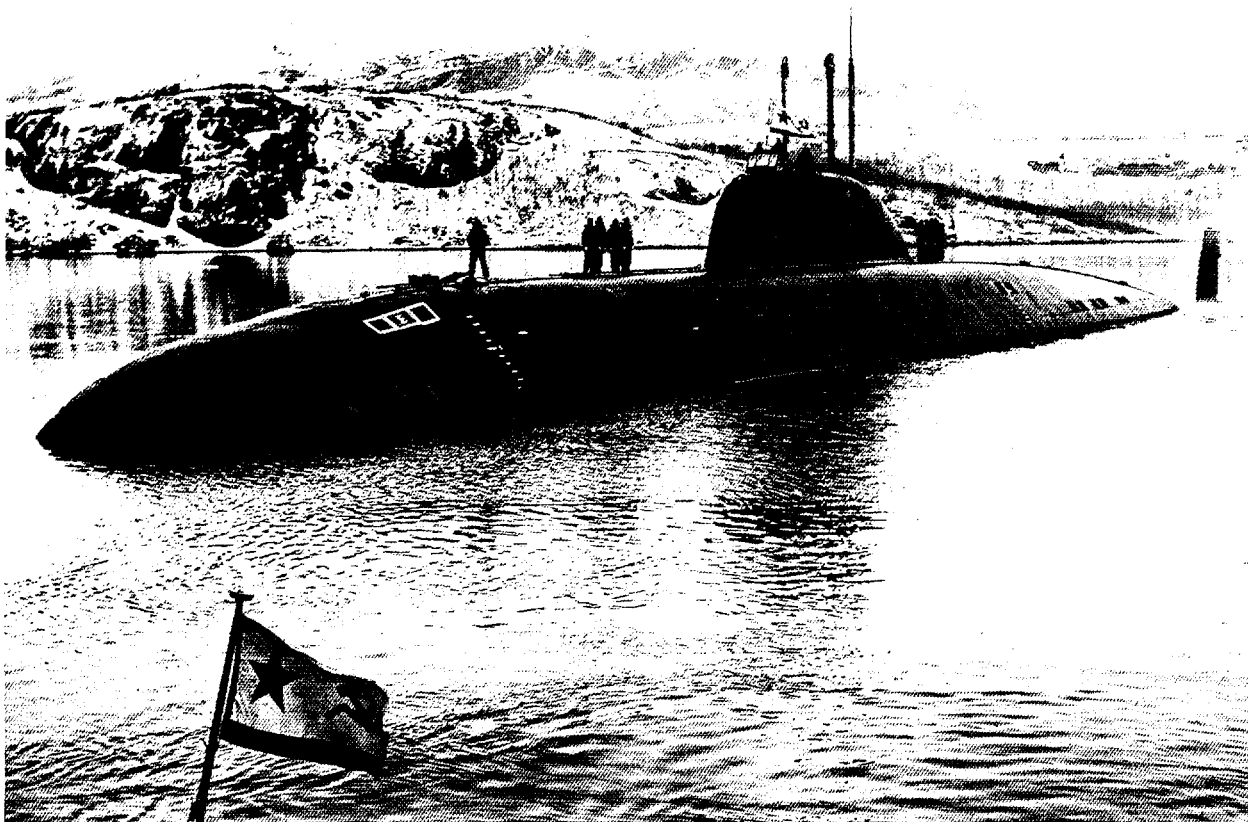

Project 671 RTM (Shchuka) - Victor-III Class

Number: 26

	Northern Fleet	Pacific Fleet	Total
In service	16	10	26
Inactive	0	0	0
Dismantled	0	0	0

Technical Data

Length: 102.2 m Displacement: 4 950/ 6990 tons
 Beam: 10 m Maximum Depth: 400 m
 Draught: 7m Hull: Low magnetic steel
 Speed: 30 knots Crew: 100

Compartments: 8

- 1: Torpedo room and accumulator
- 2: Accommodations and mess
- 3: Control room and steering
- 4: Reactor compartment
- 5: Turbines
- 6: Turbo generators
- 7: Accommodations and diesel generators
- 8: Steering and electric motor

Reactor

Two pressurised water reactors, model OK-300, with a VM-4 type reactor core generating 2 75 MWt (31 000 hp).

Nuclear Weapons

SS-N-21 cruise missiles. Two SS-N-15 or SS-N-16 missiles.

Naval Architects

G.N. Chernyshev.

Construction Yard

Komsomolsk-na-Amur; Nizhny Novgorod and Admiralty Shipyard. Constructed until 1987.

Base

Nine of the submarines are based at Bolshaya Lopatka, Zapadnaya Litsa.

Individual Submarines

Northern Fleet:

K-138 K-292 K-324 K-388 K-327 K-218
K-254 K-298 K-502 K-244 K-255 K-299
K-358 K-114 K-448 K-524

Pacific Fleet:

K-242 K-247 K-251 K-264 K-305 K-355
K-360 K-412 K-492 K-507

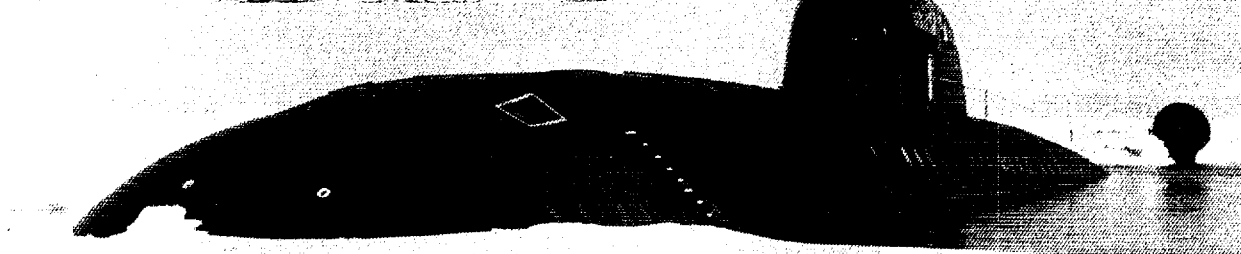
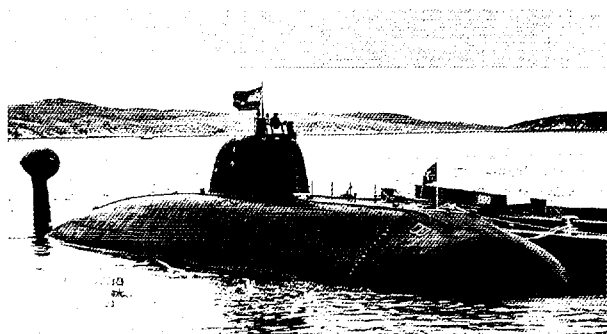

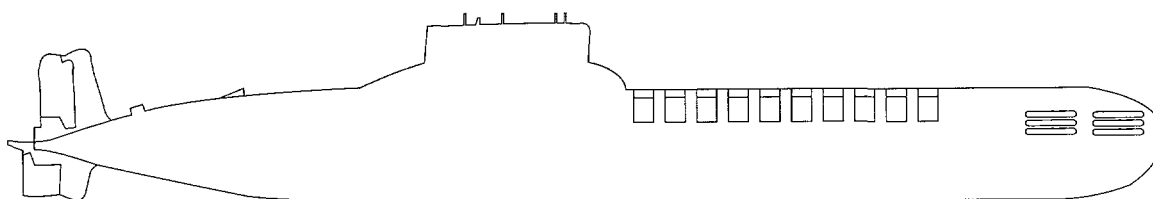

Project 941 (Akula) - Typhoon Class

Number: 6

	Northern Fleet	Pacific Fleet	Total
In service	6	0	6
Inactive	0	0	0
Dismantled	0	0	0

All of the Typhoon class submarines belong to the Northern Fleet.

Technical Data

Length: 175 m	Displacement: 24 500/33 800
Beam: 22.8 m	Hull: Low magnetic steel
Draught: 11.5 m	Crew: 170
Speed: 27 knots	Maximum Depth: 400 m

Compartments: 19

Reactor

Two pressurised water reactors, model OK-650, with VV type reactor cores generating 190 MWt with a shaft power of 2x50 000 hp.

Nuclear Weapons

20 ballistic missiles, type RSM-52 (SS-N-20).

Naval Architect

SKB-18 (Rubin), S.N. Kovalev.

Construction Yard

The Typhoon class submarines were built in Severodvinsk in the period from March 1977 until September 1989. A seventh vessel was begun but never finished.²³³

Base

All six of the Typhoon class submarines are based at Nerpi-cha in Zapadnaya Litsa.²³⁴

Commentary

In 1992, one of the Typhoon submarines was severely damaged during the test firing of a missile.²³⁵ It was eventually repaired and put into operation again. As a consequence of considerable dissatisfaction with the Typhoon concept, all submarines of this class have now been modernised with new SS-N-24/26 type missiles.²³⁶

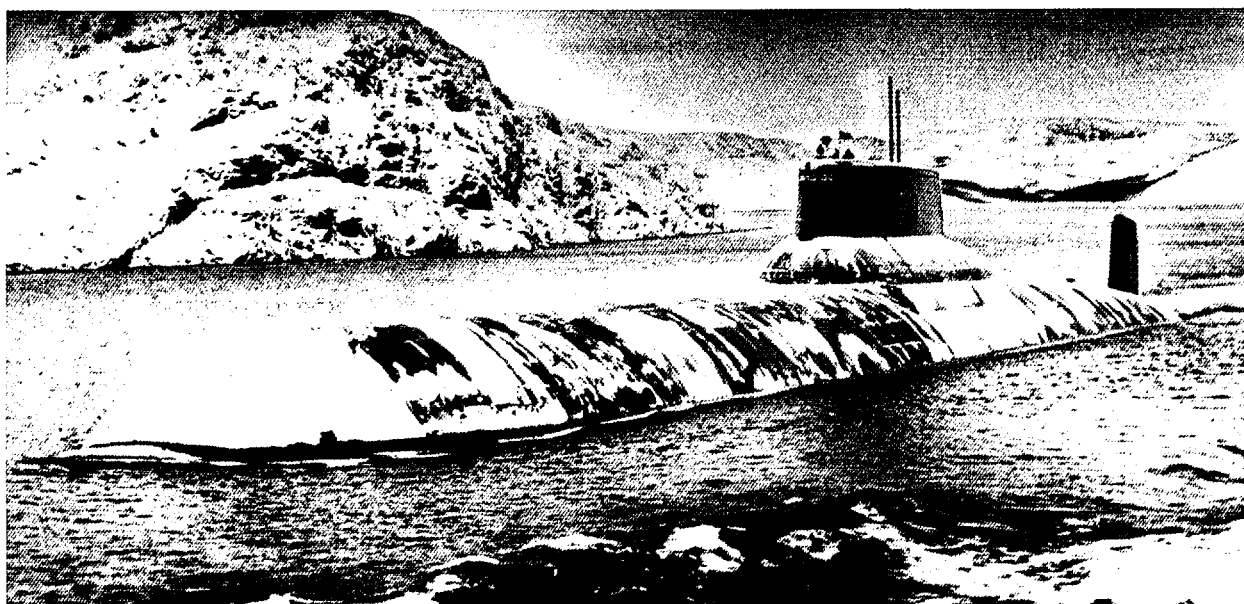

²³³ Pavlov, A.S., *Military Vessels in the Soviet Union and Russia 1945-1995*, 1994.

²³⁴ Murmanskyy vestnik, September 2, 1995.

²³⁵ *Jane's Defence Weekly*, November 4, 1995.

²³⁶ *Ibid.*

Individual Submarines

TK-208. Laid down on March 3, 1977. Launched on September 23, 1980, and commissioned on December 12, 1981.

TK-202. Laid down on October 1, 1980. Launched on April 26, 1982, and commissioned on December 28, 1995.

TK-12. Laid down on April 27, 1982. Launched on December 17, 1983, and commissioned on December 27, 1984.

TK-13. Laid down on January 5, 1984. Launched on February 21, 1985, and commissioned on December 29, 1985

TK-17. Laid down on 24 February 1985. Launched in August of 1996, and commissioned on November 6, 1987.

TK-20. Laid down on 6 January 1987. Launched in June 1988 and commissioned in September 1989.

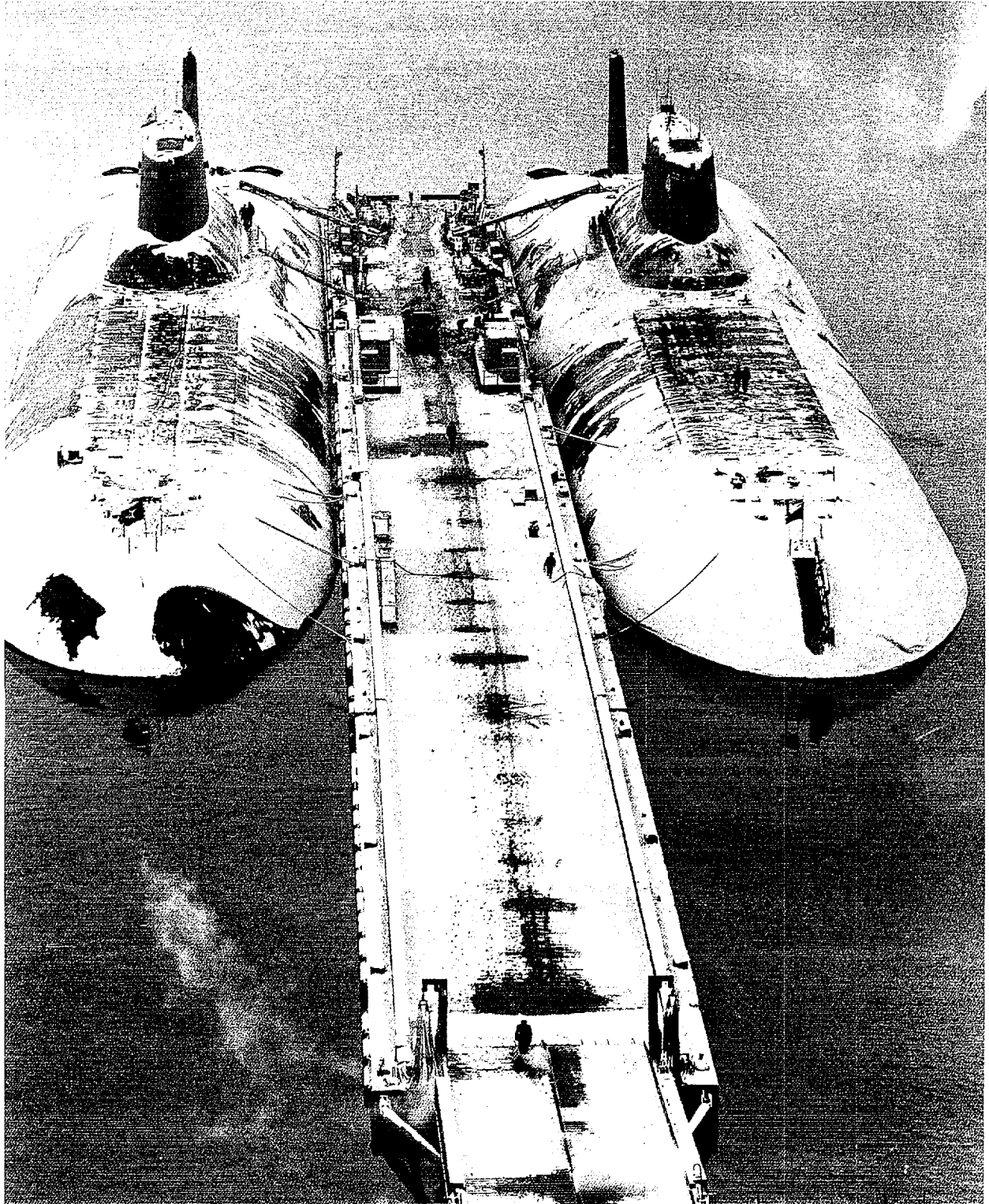

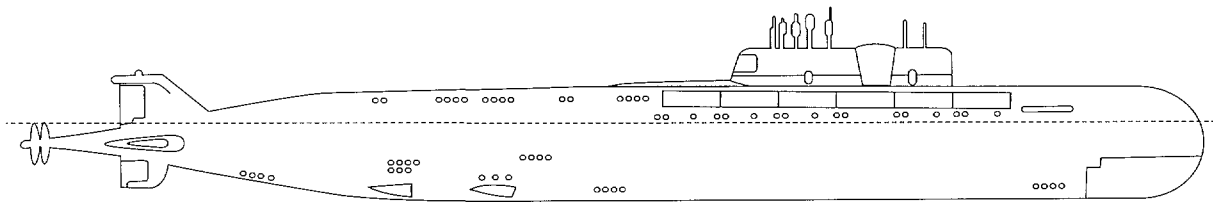

Project 949 (Granit) - Oscar-I class

Number: 2

	Northern Fleet	Pacific Fleet	Total
In service	2	0	2
Inactive	0	0	0
Dismantled	0	0	0

Technical Data

Length: 143 m	Displacement: 12 500/17 000 tons
Beam: 18.2 m	Hull: Low magnetic steel
Draught: 9 m	Crew: 130
Speed: 30 knots	Max depth: 500 m

Compartments: 10

Reactor:

Two pressurised water reactors, model OK-650 b generating 2 x 190 MWt and a shaft power of 2 x 50 000 hp.

Nuclear Weapons

24 *Granit* SS-N-19 missiles in 12 missile tubes on each side of the hull. These missile tubes are mounted outside the pressure hull of the submarine.²³⁷ Can also accommodate SS-N-15 depth charges and SS-N-16 missiles.

Naval Architects

P.P. Postinsev and I.L. Basanov.

Construction Yard

The Oscar-I submarines were built at Severodvinsk from 1978 onwards.

Base

Bolshaya Lopatka, Zapadnaya Litsa.

Individual Submarines

K-525, *Arkhangelsk*, until 1991 known as *Minsky Komsomolets*. The submarine was laid down in 1978 and commissioned in 1980.

K-206, *Murmansk*. Commissioned in 1981.

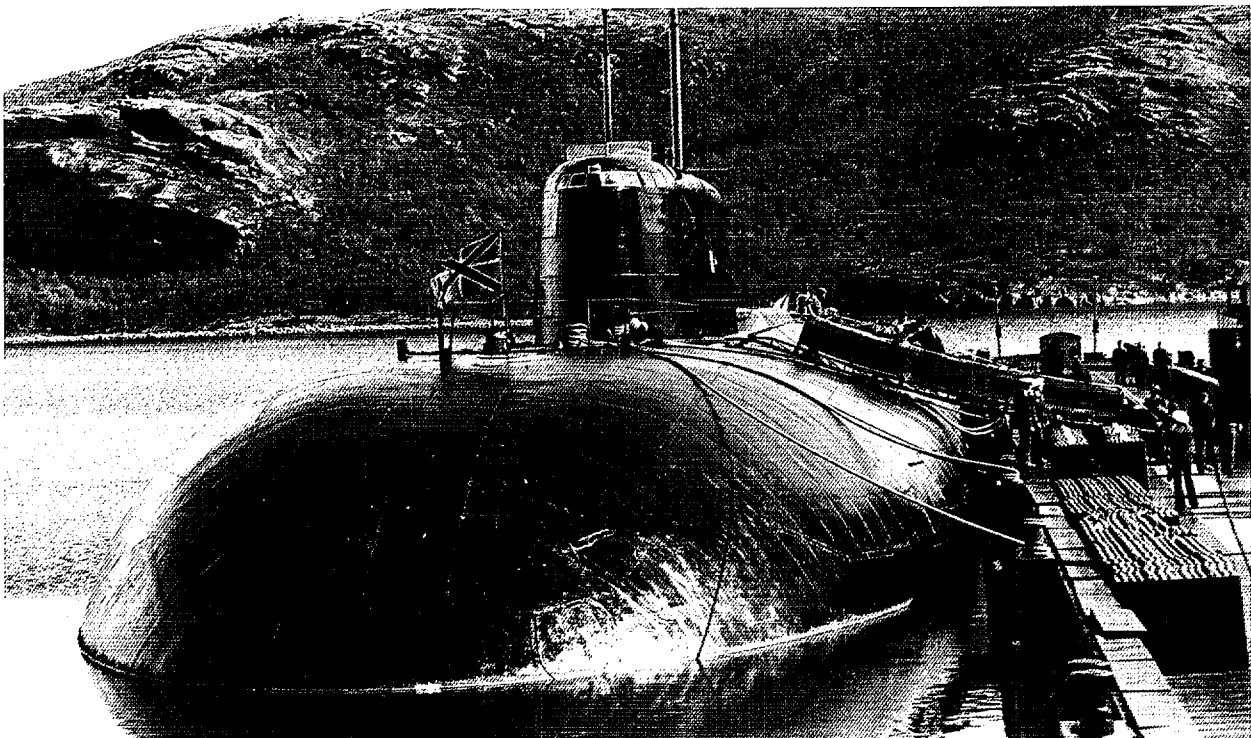

²³⁷ Krasnaya Zvezda, April 29, 1995.

Project 949 A (Antey) - Oscar-II Class

Number: 11

	Northern Fleet	Pacific Fleet	Total
In service	7	4	11
Inactive	0	0	0
Dismantled	0	0	0

Technical Data

Length: 154 m Displacement: 13 400/18 000 tons
 Beam: 18.2 m Maximum Depth: 500 m
 Draught: 9 m Hull: Low magnetic steel
 Speed: 28 knots Crew: 130

The missile tubes are located outside the pressure hull of the submarine.

Compartments: 10

Reactor

Two pressurised water reactors with a model OK-650 b reactor core generating power of 2 x 190 MWt and a shaft power of 2 x 50 000 hp.

Nuclear Weapons

24 missiles of the same type as on the Oscar-I submarine.

Naval Architects

Principal builders: P.P. Pustyntsev and I.L. Bazanov

Construction Yard

The Oscar-II submarines were built in Severodvinsk.

Base

Bolshaya Lopatka at Zapadnaya Litsa.

Individual Submarines

Northern Fleet:

- K-148**, *Krasnodar*. Commissioned in 1986.
- K-119**, *Vorone*. Commissioned in 1988.
- K-410**, *Smolensk*. Commissioned in 1990.
- K-266**, *Orel*, formerly *Severodvinsk*. Commissioned in 1992.
- K-186**, *Omsk*. Launched on May 8, 1993, and commissioned on October 27, 1993.
- K-141**, *Kursk*. Laid down in 1992 and launched in 1994. Commissioned in December 1994.

Pacific Fleet:

- K-132**, *Belgorod*. Commissioned in 1987.
- K-173**, *Chelyabinsk*. Commissioned in 1989.
- K-442**, *Tomsk*. Commissioned in 1991.
- K-456**, *Kasatka*. Commissioned to the Northern Fleet in 1991; transferred to the Pacific Fleet in September 1993.²³⁸

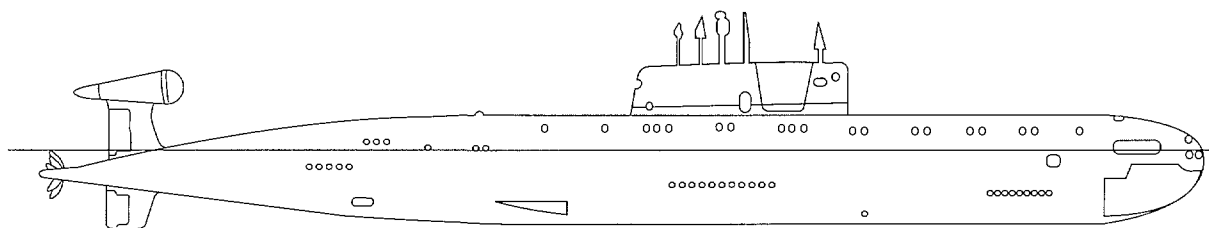

Project 945, 945 A, 945 B (Mars) - Sierra Class

Number: 6

	Northern Fleet	Pacific Fleet	Total
In service	6	0	6
Inactive	0	0	0
Dismantled	0	0	0

Technical Data

Length: 112.7 m	Displacement: 5 200/ 6 800 tons
Beam: 11.2 m	Maximum Depth: 800 m
Draught: 8.5 m	Hull: Titanium alloy
Speed: 35 knots	Crew: 60

Compartments: 7

Reactor

One pressurised water reactor, same model as that used in Project 971 (Akula) generating a power of 47 000 hp. Uses the same type of reactor as that on the Mike class submarine *Komsomolets* with a power capacity of 190 MWt. Reactor core is model OK-650.

Nuclear Weapons

One SS-N-21 cruise missile. SS-N-15 depth charge and SS-N-16 missile.

Individual Submarines

Barracuda. Laid down on May 8, 1982. Launched in July 1983 and commissioned on September 21, 1984. On February 11, 1992, *Barracuda* collided with the American submarine *Baton Rouge* just off Kildin Island near the Kola Coast. After the collision, the submarine returned to base, but it was later transferred to Zvezdochka Shipyard in Severodvinsk for upgrades, maintenance and repair. As of April 1995, *Barracuda* was still at the shipyard in Severodvinsk.

Condor. Laid down in August 1983. Launched in April 1984 and commissioned in 1986.

K-239, Carp. Laid down in April 1984. Launched in June 1986 and commissioned in 1987.

K-276, Crab. Laid down in June 1986. Launched in June 1988 and commissioned in 1990.

Naval Architects

Construction Company-112, Lazurit, N.I. Kvasya.

Construction Yard

The hull was built in Nizhny Novgorod at the factory Krasnoye Soromovo from 1982 until 1993. From here the submarines were towed in dock via inland waterways to Severodvinsk where construction and testing were completed.

Base

The Sierra class submarines are based in Ara Bay at Vidyayevo Naval Base. At the present time, the submarine *Barracuda* is undergoing repairs and modernisation at Severodvinsk.

Comments

It is maintained that the Sierra class submarines are so quiet that they cannot be detected by NATO's tracking system SOSUS.²³⁹

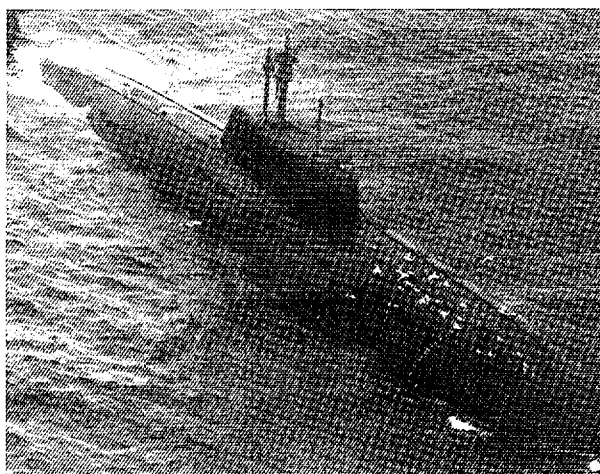

K-534, Zubatka. Laid down in June 1988. Launched in May 1990 and commissioned in 1992.

K-336, Okun. Laid down in May 1990. Launched in June 1992 and commissioned in 1993.

²³⁹ Na Stasye Zapolyariya, April 22, 1995.

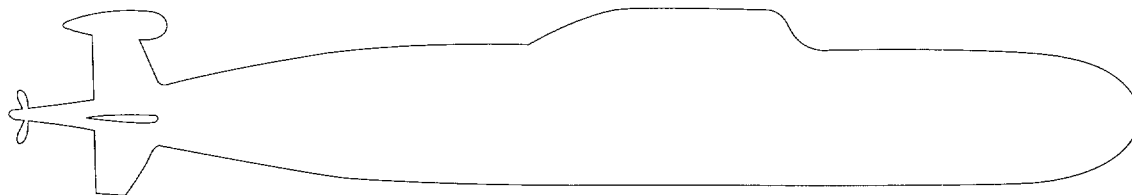

Project 971 (Shchuka-B) - Akula Class

Number: 13

	Northern Fleet	Pacific Fleet	Total
In service	6	7	13
Inactive	0	0	0
Dismantled	0	0	0
Under construction:	1	0	1

Technical Data

Length: 108 m Displacement: 5 700/7 900 tons
 Beam: 13.5 m Maximum Depth: 500 m
 Draught: 9.6 m Crew: 70
 Speed: 35 knots Hull: Low magnetic steel

Compartments: 8

Reactor

One pressurised water reactor with a model OK-650 b reactor core generating 190 MWt and a shaft power of 43 000 hp.

Nuclear Weapons

RK-55.

Naval Architect

Principal builder is G.N. Chernyshev at Malakhit.

Construction Yard

Eight of the Akula class submarines were built in Komsomolsk until activities there ceased in 1993. The remaining submarines have been built or are under construction in Severodvinsk.

Base

All of the Akula class submarines belong to the Northern Fleet are based at Gadzhievo.

Comments

The Akula submarines are the fastest and quietest of all Russian attack submarines. During the first half of 1995, the American submarine tracking system was unable to track a submarine of this class which was on patrol off the eastern coast of the United States.²⁴⁰ The vessel is at its quietest at a speed of 6 - 9 knots. Starting with the eighth submarine of production, the class is now known as Akula-II.²⁴¹ These submarines are quieter and more modern than their immediate predecessor.

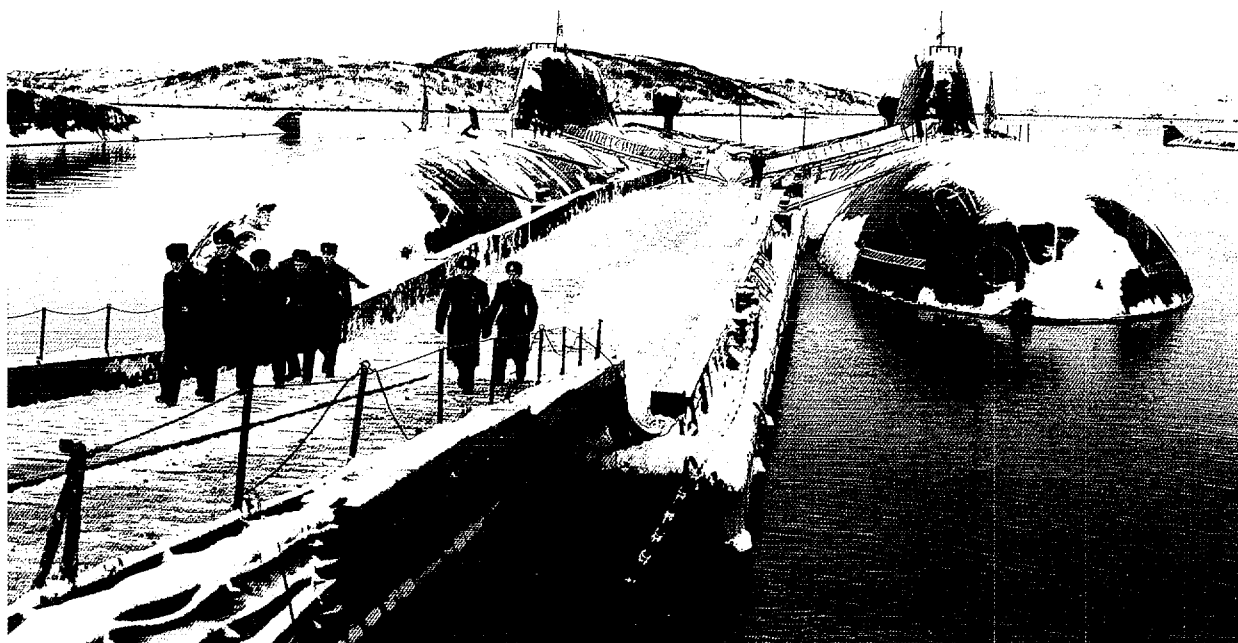

²⁴⁰ *Jane's Defence Weekly*, No. 11, September 16, 1995.

²⁴¹ R. Lee, *State of the Russian Navy data page*, last updated January 9, 1996.

Individual Submarines**Northern Fleet:**

K-480 *Bars*. Laid down in 1982, launched in 1983 and commissioned in December 1984.

K-317 *Pantera*. Laid down in November 1982, launched in May, 1990, and commissioned in December 1990.

K-461 *Volk*. Laid down in 1986, launched on July 11, 1991 and commissioned on January 27, 1992. On February 23, 1996 the submarine returned to the base, after a patrol which started with a leakage in the fire protection system in the navigation-room.²⁴²

K-328 *Leopard*. Laid down in October 1988, launched on October 6, 1992, and commissioned in 1993.

K-157 *Tigr*. Laid down in 1989, launched on July 10, 1993 and commissioned in December, 1994.

K-? *Vepr*. Laid down in 1992, launched in 1993 and was scheduled for delivery to the Russian Navy in 1995. In the summer of 1995, the submarine's steam plant was connected and the reactor tested and approved.²⁴³

K-? *Gepard*. Laid down in 1991, launched in 1992. Due for delivery to the Russian Navy in 1995.²⁴⁴

Pacific Fleet:

K-284. Launched on October 6, 1982 and commissioned on December 30, 1984.

K-263. Launched on July 15, 1984 and commissioned in December, 1985.

K-322. Commissioned in 1986.

K-391. Commissioned in 1987.

K-331. Commissioned in 1988.

K-419. Commissioned in 1989.

K-267 *Drakon*. Launched on August 4, 1994, and commissioned in 1995.

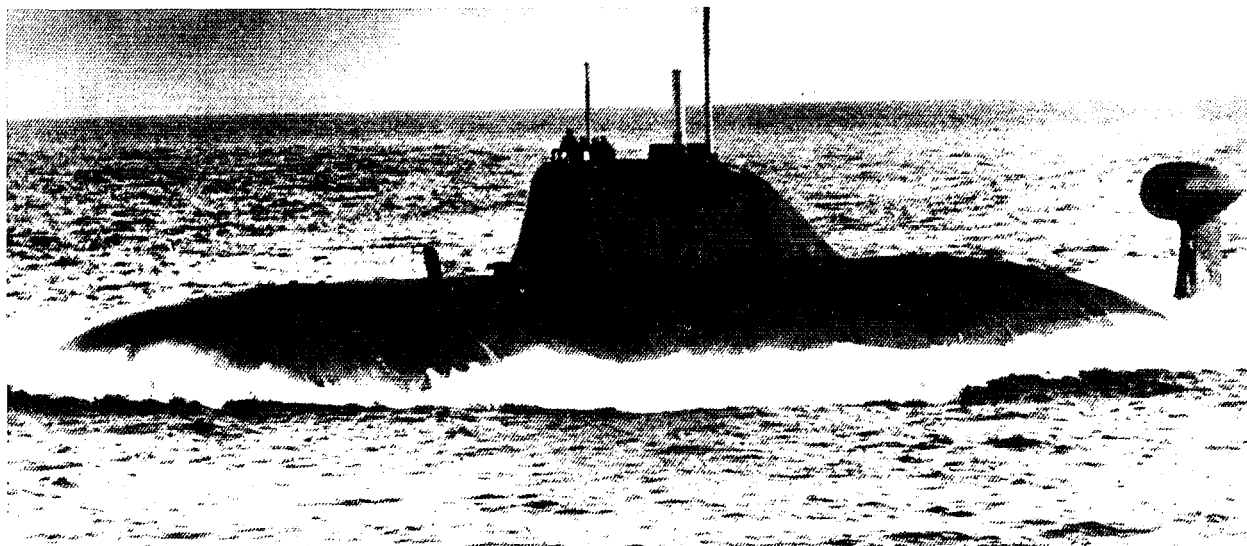

242 *Krasnaya Zvezda*, April 3, 1996.

243 *Krasnaya Zvezda*, May 27, 1995.

244 *Severny Rabotshy*, January 19, 1995.

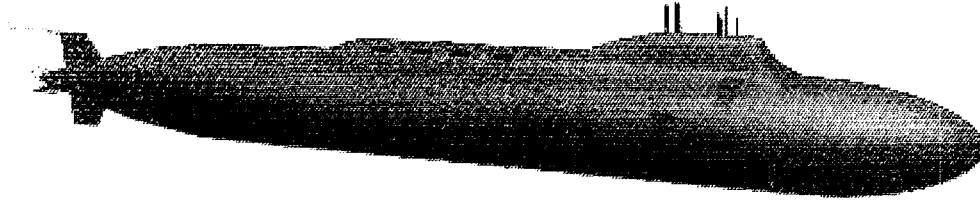

Project 885 - Severodvinsk Class

Number: -

	Northern Fleet	Pacific Fleet	Total
In service	0	0	0
Inactive	0	0	0
Dismantled	0	0	0
Under construction:	-	-	3

Technical Data

Length: 111 m Displacement: 5 800/8 200 tons
 Beam: 12 m Maximum Depth:
 Draught: 8.4 m Hull: Low magnetic steel
 Speed: 31 knots Crew: 50

Reactor

One KPM type pressurised water reactor generating power capacity from the turbines of 43 000 hp, 200 MWt.²⁴⁵

Nuclear Weapons

One *Oniks* SS-N-17 missile.

Naval Architects

J.N. Kormilitsin, SKB-18.

Construction Yard

These submarines are being built in Severodvinsk. Construction started on December 28, 1993, and the first of this class was launched in 1995. It is scheduled to be commissioned before 1998.

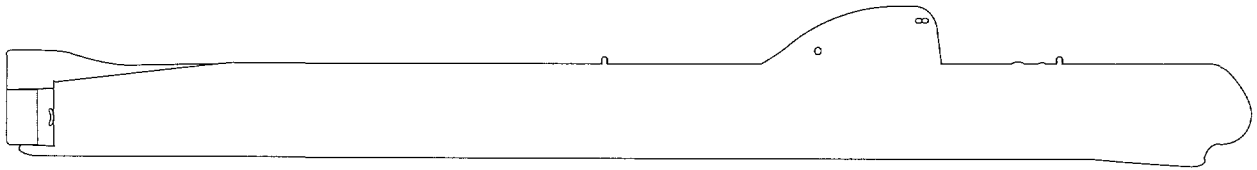

Project 645 November-ZhMT

Number: 1

This submarine was based on the hull of the November class submarines, and belonged to the Northern Fleet. Only one Project 645 ZhMT submarine was ever built.

Technical Data²⁴⁶

Length: 109.8 m Displacement: 3 420/4 380 tons
 Beam: 8.3 m Maximum Depth: 300 m
 Draught: 5.85 m Hull: Low magnetic steel
 Speed: 30 knots Crew: 105

Only a few years after construction, cracks were discovered in the metal-hull due to corrosion between the crystals. Apart from a few changes in the bow, the Project 645 submarine is identical to submarines of the November class in order to shorten the construction time.

Compartments: 9

- 1: Torpedo room
- 2: Accumulators and Living accommodation
- 3: Control room
- 4: Reactor compartment
- 5: Turbo and diesel generators, cooling and auxiliary machinery
- 6: Turbines
- 7: Generator

Reactors²⁴⁷

Two VT-1 type liquid metal (lead-bismuth) cooled reactors with a capacity of 146 MWt and shaft power of 35 000 hp. A test reactor of the same type as that used on board K-27 was in use at Obninsk as early as 1955. A new steam-boiler was developed especially for this submarine that required considerably less electrical power in the start phase and during cooling. Subsequently the capacity of the batteries was only 75% of those on board the November class submarines.

Naval Architect

V.N. Peregrudov, SKB-143.

Construction Yard

The Project 645 ZhMT was built in Severodvinsk.

Individual Submarines

K-27, factory no. 601. The only one built of this class. Laid down on June 15, 1958. Launched on April 1, 1962 and commissioned to the Northern Fleet on October 30, 1963. Based at Zapadnaya Litsa. There was a serious accident involving the reactor and 9 people died of radiation injuries. Attempts to repair the reactor were futile; hence the entire submarine was scuttled at a depth of 50 meters in Stepovogo Bay at Novaya Zemlya in 1981, see picture below.²⁴⁸

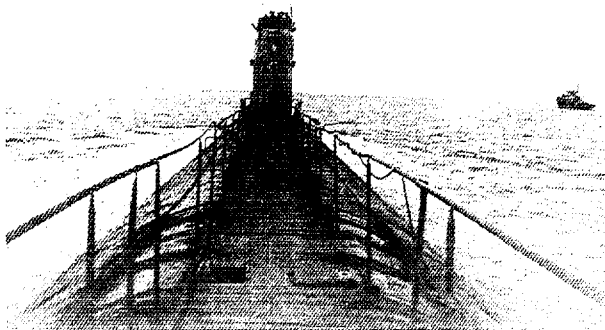

²⁴⁶ Morskoj sbornik, No. 8 - 1993.

²⁴⁷ Ibid.

²⁴⁸ Yablokov, A. V., *Facts and problems related to radioactive waste disposals in seas adjacent to the territory of the Russian Federation*, Moscow 1993.

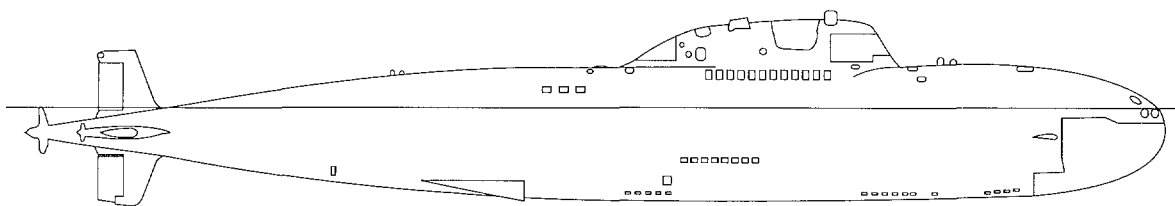

Project 705, 705 K (Lira) - Alfa Class

Number: 7

	Northern Fleet	Pacific Fleet	Total
In service	1	0	1
Inactive	6	0	6
Dismantled	2	0	2

All of the Alfa submarines have been or are assigned to the Northern Fleet.

Technical Information

Length: 81.4 m Displacement: 2 310/3 120 tons
 Beam: 9.5 m Maximum Depth: 750 m
 Draught: 7.6 m Hull: Titanium Alloy
 Speed: 41 knots Crew: 30

Compartments: 6

Only two compartments in the submarine are manned. All other operations are executed from the control room.

Reactor²⁴⁹

One liquid metal (lead bismuth) cooled reactor, model BM-40A/VOK-550, generating 155 MWt. The mixture of lead and bismuth utilised in the reactor has a high boiling point (1.679 C). Therefore, it is unnecessary to keep the reactor under pressure as is the case with water cooled reactors. Conversely, it is important to keep the reactors constantly heated so that the metal solution does not solidify, as it will if the temperature falls below 125 C. If the solution hardens, it will be impossible to restart the reactor, for the fuel assemblies will have been frozen in the solidified coolant. Near the piers where the submarines were moored, a special facility was constructed to deliver superheated steam to the vessels' reactors when the reactors were shut down. A smaller ship was also stationed at the pier to deliver steam from its steam plant to the Alfa submarines; however, this method of external heating proved to be unsatisfactory, and the submarine reactors consequently had to be kept running even while they were in harbour. The facilities completely broke down early in the 1980s, and since then, the reactors of all of the operational Alfa submarines were kept constantly running. This led to extra wear on the reactors and required that the vessels be constantly manned. Indeed, the difficulty of trying to externally heat the submarine

reactors was one of the reasons that the Alfa class was taken out of service in the late 1980s. The reactors of the Alfa class submarines were never refuelled as were the pressurised water reactors of other types of submarines, for it was simply not technically possible to remove the fuel assemblies without the metal coolant solidifying in the process. The term "single use reactors" is therefore applied to the Alfa reactors. The reactors of the Alfa class submarines had an operational lifetime of 70 years altogether.

Nuclear Weapons

Fitted for 82-R (SS-N-15) torpedoes.

Naval Architects

Principal constructor:

SKB-193 (Malakhit), M.G. Rusanov and V.A. Romin, naval architects.

Construction Yard

Admiralty Yard in St. Petersburg and Severodvinsk.

Base

The Alfa class submarines were based at Bolshaya Lopatka in Zapadnaya Litsa. Three of the vessels are still there.

Comments

The Alfa class submarine was built for speed; hence it was of small consequence that it was noisy, for it could escape from any torpedoes fired at it. The Alfa submarines had an operation endurance of one month.

249 Atomnaya Energia, vol. 73, no. 1 - 1992 and vol. 76, no. 2 - 1994.

Individual Submarines

- K-377**, (K-47), factory no. 900. (Commanding Officer: A.S. Pushkin) This submarine suffered a reactor accident in 1972 during sea trials. The metal coolant "froze" and it was therefore impossible to remove the reactor fuel. After this trial period, the submarine was dismantled. The reactor compartment (no. 140) was filled with furfural and bitumen and placed on a barge for transport to the Kara Sea where it would be dumped. However, just as the barge holding the reactor was being towed out of Severodvinsk, word came from the Soviet Department of the Environment that the London Convention had just been signed and the reactor was not to be dumped at sea. Subsequently, the barge was instead towed to the island Yagry outside Zvezdochka Shipyard where it remains today. On December 21, 1994 it was decided to move the reactor-section to Gremikha, where it will be stored on shore.²⁵⁰
- K-123**, factory no. 105. Built at Severodvinsk. Launched on December 26, 1977. The original reactor compartment was removed in 1982 following an accident, and a new one installed.²⁵¹ Liquid metal from the primary cooling circuit leaked out and contaminated the entire reactor compartment. It took eight years to change reactors, and the submarine was finally launched again in 1990. Recommissioned in 1991, it was scheduled for decommissioning over the course of 1995.²⁵²
- K-432**, factory no. 106. This submarine is in the process of being dismantled at Sevmash Shipyard in Severodvinsk.²⁵³ The reactor core was removed in Gremikha and is being stored there. The reactor compartment was scheduled to be towed to Sayda Bay over the course of 1995.²⁵⁴
- K-463**, factory no. 915. Decommissioned at Sevmash Shipyard sometime after 1986. The fuel has been removed from the reactor and is being stored at Gremikha. In 1994, the reactor compartment was towed to Sayda Bay on the Kola Peninsula, and it is moored there today.²⁵⁵ The compartment was filled with 20 tons of solid radioactive waste before it was cleaned and towed away from Severodvinsk.²⁵⁶
- K-493**, factory no. 107. Laid up in Zapadnaya Litsa.²⁵⁷ The reactor core was removed in Gremikha where it is now being stored. The submarine is scheduled to be towed to Severodvinsk to be dismantled at Sevmash Shipyard.²⁵⁸
- K-373**, factory no. 910. Laid up in Zapadnaya Litsa; the reactor fuel has not been removed.
- K-316**, factory no. 905. Work on dismantling this submarine started in the autumn of 1995 and is ongoing at Sevmash Shipyard in Severodvinsk.²⁵⁹ The reactor core was removed at Gremikha where it is now being stored. The reactor compartment was scheduled to be towed to Sayda Bay over the course of 1995.

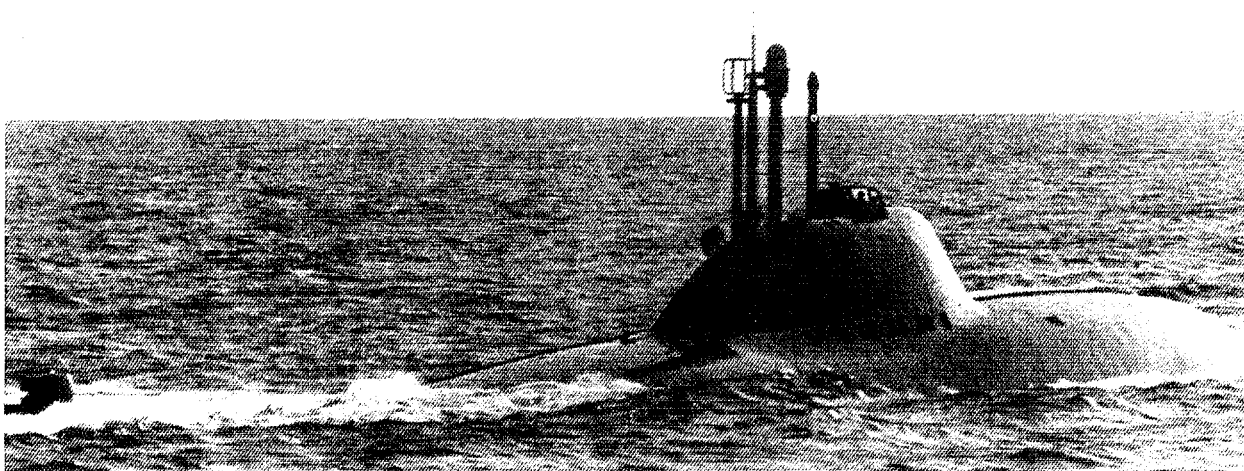

250 *Problems with decommissioning of nuclear submarines and protection of the environment in the arctic areas.*, page 29-30, Severodvinsk, March 15.-16. 1995.

251 Mormul, N., Note, 1995.

252 *Jane's Fighting Ships 1995-96*, 98th edition.

253 *Problems with decommissioning of nuclear submarines and protection of the environment in the arctic areas.*, page 29-30, Severodvinsk, March 15.-16. 1995.

254 Visit in Sayda Bay, Spring 1995.

255 *Ibid.*

256 *Severny Rabochy*, November 18, 1994.

257 Mormul, N., Note, 1995.

258 Sjmakov, R. A., Lecture presented in the document *Problems with decommissioning of nuclear submarines and protection of the environment in the arctic areas.*, Severodvinsk, March 15.-16. 1995. And Mormul, N., Note, 1995.

259 *Problems with decommissioning of nuclear submarines and protection of the environment in the arctic areas.*, page 29-30, Severodvinsk, March 15.-16. 1995.

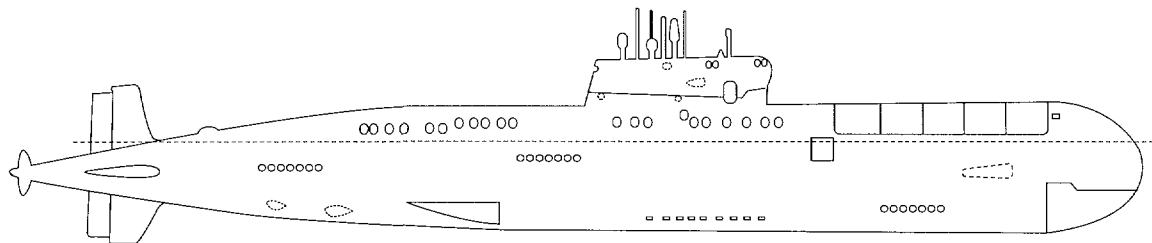

Project 661 (Anchar) - Papa Class

Number: 1

	Northern Fleet	Pacific Fleet	Total
In service	0	0	0
Inactive	1	0	1
Dismantled	0	0	0

Technical Data

Length: 106.9 m Displacement: 5 197/7 000 tons
 Beam: 11.6 m Maximum Depth: 400 m
 Draught: 8 m Hull: Titanium alloy
 Speed: 44.7 knots Crew: 82

Compartments: 9

- 1 and 2: Torpedo room and accumulators
- 3: Accommodations and accumulators
- 4: Control room and accommodations
- 5: Reactors
- 6: Turbines
- 7: Turbo generators
- 8: Machinery
- 9: Navigation/steering mechanisms

Reactor

Two VM-5m type pressurised water reactors generating 177.4 MWt and a shaft power of 80 000 hp.

Naval Architect:

Principal designer:

Director of UKB-16 N.N. Isanin and N.F. Shulshenko.

Construction Yard

Built in Severodvinsk.

Individual Submarines

K-222, formerly K-162, factory no. 501. Built in Severodvinsk. Laid down on December 28, 1963, and commissioned on December 31, 1969. The submarine is now moored at Bolomorsk Naval Base in Severodvinsk, but it is unclear when dismantling work will commence.²⁶⁰ Since the hull is made of titanium alloy, the submarine will be dismantled at Sevmash. The reactors have not been defuelled.

²⁶⁰ *Severny Rabotshy*, March 7, 1995.

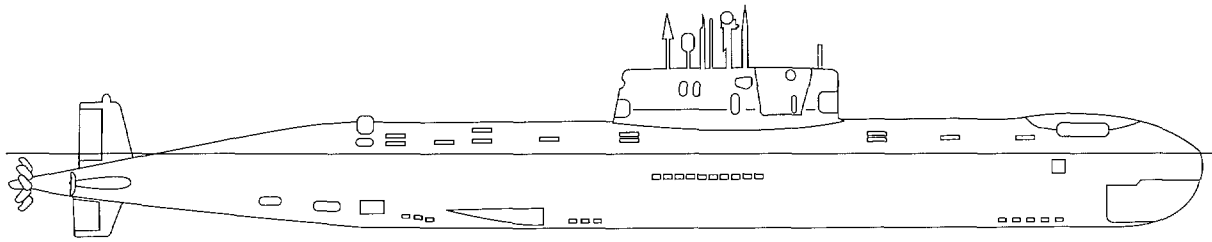

Project 685 (Plavnik) - Mike Class

Number: 1

	Northern Fleet	Pacific Fleet	Total
In service	0	0	0
Inactive	0	0	0
Dismantled	0	0	0
Sunk:	1 ²⁶¹	0	1

The submarine K-278, *Komsomolets*, was built as an experimental vessel and was the only one of its class.

Technical Data

Length: 120 m Displacement: 6 400 tons
 Beam: 12 m Maximum Depth: 1 020 m
 Draught: 8 m Hull: Titanium alloy
 Speed: 30 knots Crew: 64

Compartments: 7

- 1: Torpedo room
- 2: Accommodations
- 3: Control room
- 4: Reactor compartment
- 5: Electrical motors
- 6: Turbines
- 7: Auxiliary mechanisms

Reactor

One pressurised water reactor, model OK-650 b-3 generating 190 MWt which gave a shaft power of 43 000 hp.

Nuclear Weapons

Two RK-55 type torpedoes.

Naval Architect:

Principal designer:

N.A. Klimov and J.N. Karmilitsin, SKB-18 (Rubin).

Construction Yard

K-278 *Komsomolets* was laid down in Severodvinsk on April 22, 1978. The submarine was launched on May 9, 1983, and commissioned at the end of 1984. The construction of one other Mike class submarine was started in Severodvinsk, but work was halted.

Base

The submarine *Komsomolets* was based at Bolshaya Lopatka at Zapadnaya Litsa until its sinking in April 1989.

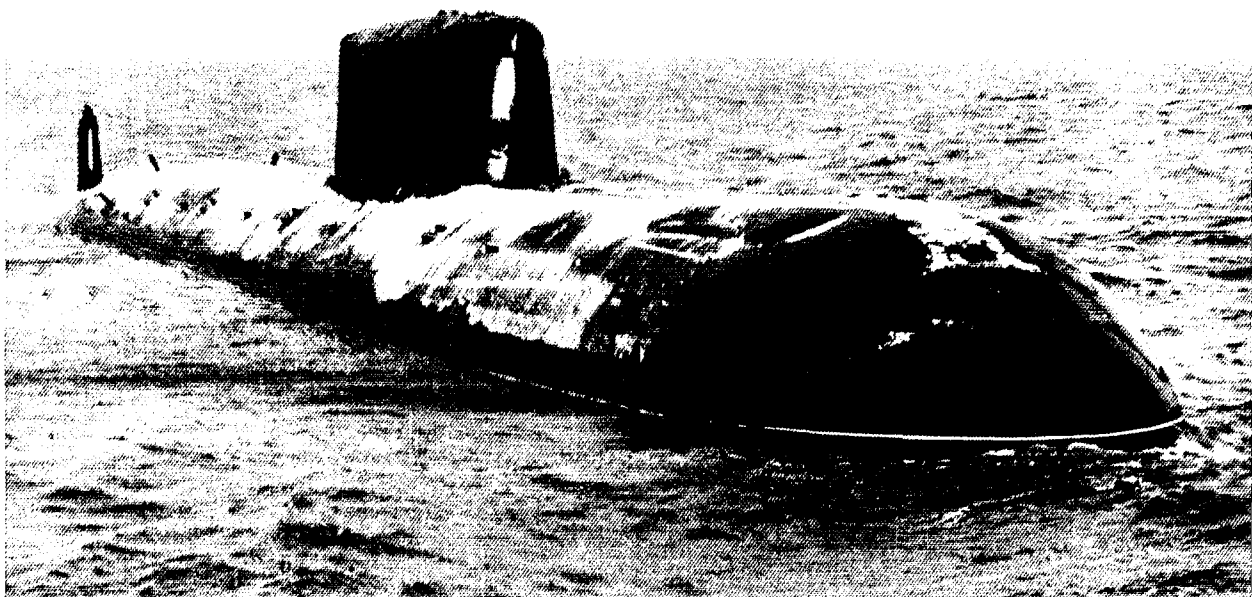

Prosjekt 1851 - X-ray**Number**

There is one active mini-submarine of this class in the Northern Fleet. It is called AS-11.

Technical Data

Length: 40 m Displacement: 550/1 000 tons
Beam: 5.3 m Draught: 5 m

Reactor

One pressurised water reactor, model unknown. Yields a power of 10 Mwt.

Construction Yard

This submarine was built at the Admiralty Yard in St. Petersburg in 1982.

Project 1910 - Uniform**Number**

Three mini-submarines of this type are active with the Northern Fleet.

Technical Data

Length: 69 m Displacement: 1 390/2 000 tons
Beam: 7 m Hull: Unknown
Draught: 5.2 m Crew: 36
Speed: 30 knots

Reactor

One pressurised water reactor, model unknown, generating 10 MWt which gave a shaft power of 10 000 hp.

Construction Yard

Built at the Admiralty Yard in St. Petersburg in the period from 1982 to 1994.

Individual Submarines

AS-15. Laid down in November 1982. Commissioned in July 1983.

AS-16. Laid down in April 1988. Commissioned in November 1989.

AS-? Commissioned in 1994.

Prosjekt 10831**Number**

The Northern Fleet has one active mini-submarine of this class in service called AS-12.

Technical Data

Length: 40 m Displacement: 600/1 100 tons
Beam: 6 m Maximum Depth: 1 000 m
Draught: 5.1 m Crew: 20
Speed: 30 knots

Reactor

One pressurised water reactor, model unknown. Power capacity from the turbines is 10 000 hp.

Construction Yard

The Project 10831 submarine was built in Severodvinsk.

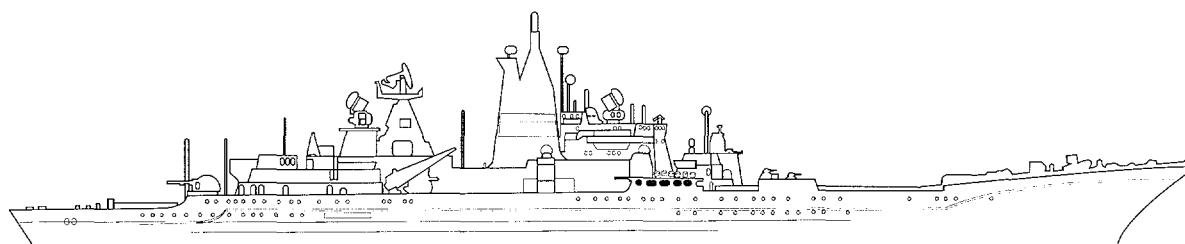

Project 1144 (Orlan) - Kirov

Number: 3

	Northern Fleet	Pacific Fleet	Total
In service	2	1	3
Inactive	0	0	0
Dismantled	0	0	0
Under construction:	-	-	1

Technical Data

Length: 251.2 m Displacement: 28000 tons
 Beam: 28.5 m Crew: 610
 Draught: 9.1 m Speed: 30 knots

Reactor

Two pressurised water reactors, model KN-3 generating 300 MWt and a shaft power of 140 000 hp.

Construction Yard

All four battle cruisers were built at Baltiysky Shipyard (formerly Shipyard-189) in St. Petersburg.

Individual Vessels

Northern Fleet:

Admiral Ushakov (until April 22, 1992 known as *Kirov*). Keel laid down on March 27, 1974. Launched on December 27, 1977, and commissioned by the Navy on December 30, 1980. Based at Seve

romorsk. Inactive since 1990 when there was an accident in the ship's machinery.²⁶²

Admiral Lasarev (until 1992 known as *Frunze*). Laid down on July 27, 1978. Launched on May 26, 1981, and commissioned on October 31, 1984. The ship is based at Severomorsk, but has been laid up over the last few years. It is expected that the vessel will be decommissioned.²⁶³

Pacific Fleet:

Admiral Nakhimov (until 1992 known as *Kalinin*.) Keel laid down on May 17, 1983. Launched on April 25, 1986, and commissioned on December 30, 1988.

Pyotr Veliky (until 1992 known as *Yury Andropov*). Keel laid down on April 25, 1986. Launched on April 25, 1989, and first sea trial completed in autumn 1995. The battle cruiser is scheduled to be transferred to the Pacific Fleet over the course of 1996.²⁶⁴



262 R. Lee, *State of the Russian navy data page*, last updated on January 9, 1996.

263 *Jane's Fighting Ships* 1996-96, 98th edition.

264 *Krasnaya Zvezda*, October 13 1995.

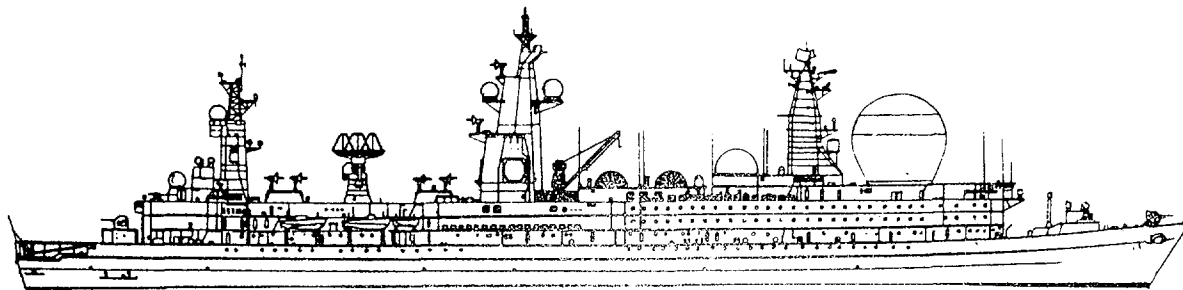

Project 1941 (Titan) - Kapusta Class

So far, only one ship in the Project 1941 Kapusta class has been built, SSV - *Ural*. This vessel is a huge communications and operations ship, and is attached to the Pacific Fleet. However, due to problems with the ship's advanced equipment, it has mostly been laid up since its commissioning in 1989.

Technical Data

Length: 265 m Displacement: 34 640 tons
Beam: 29.9 m Crew: 923
Draught: 7.81 m Speed: 21.6 knots

Reactors

Two pressurised water reactors, model KN-3 (OK-900) with a VM-16 type reactor core generating 171 MWt. The reactors are used in tandem with an oil turbine and together generate 66 500 hp.

Construction Yard

Ural was built at Baltisky Shipyard in St. Petersburg. The keel was laid down on July 25, 1981. It was launched in May 1983 and commissioned on December 30, 1988. The vessel was taken out of use a short time later, and there are now plans to either sell or decommission the ship.²⁶⁵

²⁶⁵ Ibid.

Service ships and special tankers

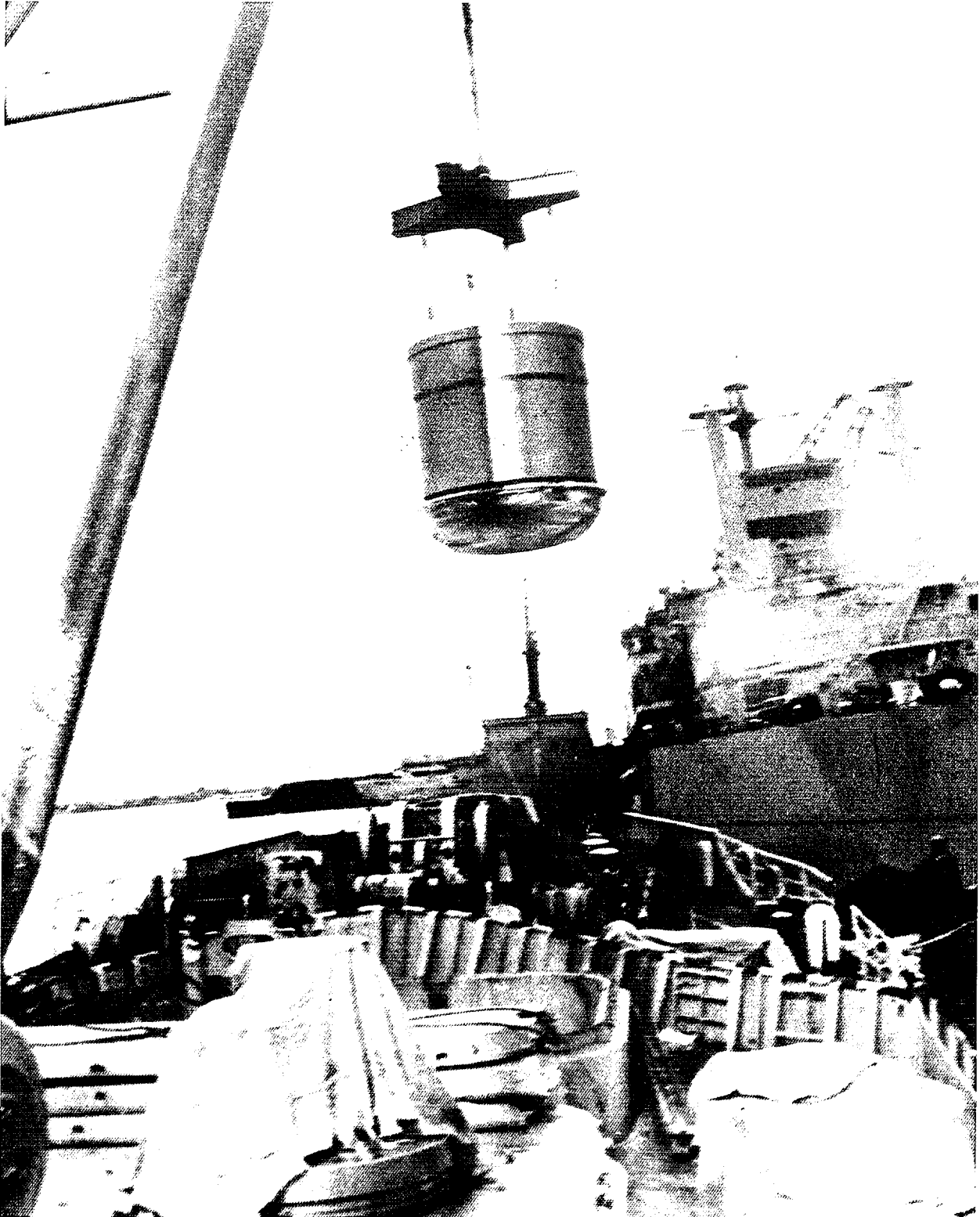

Chapter 3

Service ships and special tankers

The Russian Northern Fleet possesses a number of service ships that are used for the transportation and storage of radioactive waste and spent nuclear fuel. A number of these ships were originally used for collecting liquid and solid radioactive wastes which were then dumped in the Barents and Kara Seas. (For a more detailed discussion of Russian dumping practices, see Bellona report no. 1 - 1994.)²⁶⁶

Most of the service ships are connected to the navy yards where nuclear submarines are serviced. At the present time, there are six tankers for liquid radioactive waste in commission with the Northern Fleet. In addition, seven ships/barges are used for the storage of spent fuel. Some of the vessels used for the transportation and storage of spent fuel are also capable of storing liquid waste. Most of the service ships do not comply with current safety standards.²⁶⁷ The main reason for this is that the ships are old and run down, and routine maintenance has been neglected. All of the tankers in Project 1783 A - Vala class are more than 25 years old.

Even when firm instructions for repair are specifically given, they are rarely followed. The Russian Ministry of Defence's central committee for radiation safety has prohibited the further use of some of the ships for the transportation and storage of radioactive waste. However, the Northern Fleet Command has elected to overlook these instructions.²⁶⁸

Many of the service ships lack the instrumentation for radiation measurements, and dosimeter checks for the crew are very infrequent. Though they may still remain in service, 84 % of the tanks and tankers for liquid waste are classified as damaged.²⁶⁹ Documentation on the ship, its condition and its cargo, although mandatory, is often unsatisfactory. Breaches of regulations are

especially common with regards to the transportation of spent nuclear fuel. It has been reported that the ships are often manned by crews of less than half the necessary complement and the men are lacking in education and training.²⁷⁰ Furthermore, some of the equipment used in loading and unloading the waste is in very poor technical condition. The transport routes of these ships are described in Chapter 7.

3.1

Service ships for liquid radioactive waste

The Northern Fleet operates specially constructed tankers of Project 1783 A - Vala class to transport and store liquid radioactive waste on the Kola peninsula. These vessels are based at Zapadnaya Litsa, Gadzhievo, Gremikha and Severodvinsk.²⁷¹ In addition to these comes *Amur* of Project 11510 - Belyanka class. The rebuilt tanker *Osetiya* is based at Severodvinsk. Even though the ship still contains liquid radioactive waste, she is no longer in active service.²⁷² The Northern Fleet also operates numerous PE-50 type floating tanks, each of which can store up to 50 m³ of liquid radioactive waste.²⁷³

The transfer of liquid waste from submarine reactors is conducted through hose pipes to storage tanks inside the service ships whereupon the waste is transported to the storage facilities at Andreeva Bay or to the treatment plant for liquid radioactive waste at the Atomflot base for civilian nuclear icebreakers in Murmansk.

266 Nilsen, T and Böhmer, N., Sources of Radioactive Contamination in Murmansk and Arkhangelsk Counties, Bellona Report no.1 :1994.

267 Gosatomnadzor has conducted several inspections in co-operation with navy agencies and is referred to in documents of 1993 and 1994.

268 Mormul, N. Note, 1995.

269 Komsomolskaya Pravda, June 23, 1995.

270 Gosatomnadzor has conducted several inspections in co-operation with navy agencies and are referred to in documents of 1993 and 1994.

271 Mormul, N. Note, 1995.

272 Handbook On implementation plan for handling of nuclear waste and spent fuel on Severodvinsk territory, Summer 1994.

273 Mormul, N. Note, 1995.

Project 1783 A - Vala class

Number: 9²⁷⁴

	Northern Fleet	Pacific Fleet	Total
Active	4	4	8
Inactive	1 ²⁷⁵	0	1
Decommissioned	0	0	0

Seven ships of the Zeya class were to have been built for the transportation of liquid radioactive waste. This class is very similar in construction to the Vala class. All of them are reputed to be radioactively contaminated and in poor technical condition. None of the ships are in service at this time.²⁷⁶

Technical data²⁷⁷

Length: 76.2 m Displacement: 3 100 tons

Beam: 12 m Crew: 30

Draught: 5 m Speed: 14 knots

The Vala class ships were built in Vyborg and Vladivostok in the period 1964-1971.

Storage capacity

870 m³. Maximum permissible radiation level is 10⁻⁵ curies per litre.²⁷⁸

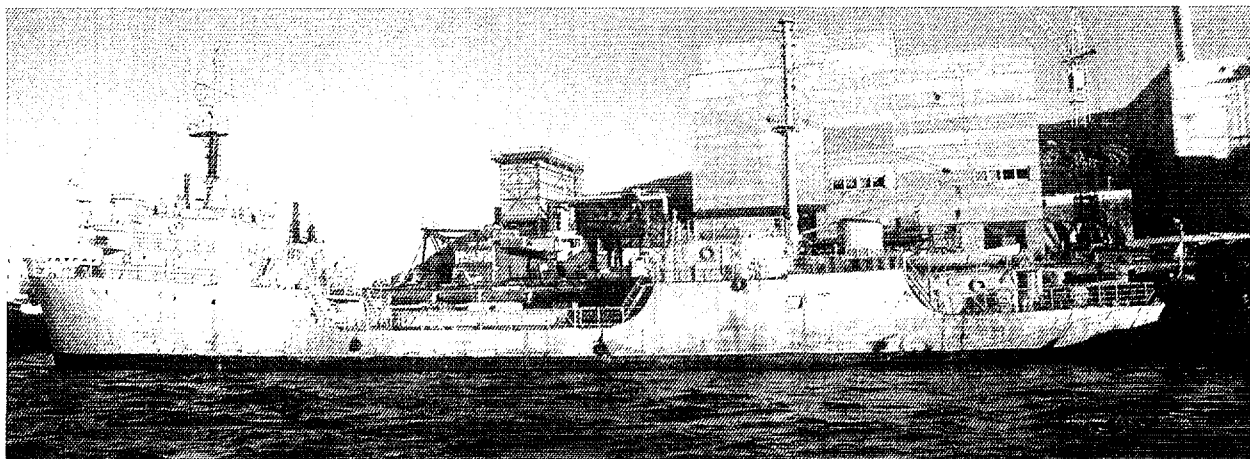

One of the Northern Fleet's Project 1783 A type service ships moored at *Atomflot*, the base in the Murmansk Fjord for the civilian nuclear icebreaker fleet. *Atomflot* has a purification plant for liquid radioactive waste and also has the capacity to process similar such waste from the Northern Fleet. The Northern Fleet has five Project 1783 A service ships, all of which are in very poor technical condition.

274 *Jane's Intelligence Review*, December 1993.

275 Pavlov, A. S., *Military Vessels in the Soviet Union and Russia 1945 - 1995*, 1994

276 *Jane's Fighting Ships* 1995 - 96, 98th edition.

277 Pavlov, A. S., *Military Vessels in the Soviet Union and Russia 1945 - 1995*, 1994.

278 Perovsky, V. A., Handbook presented to the Murmansk County Committee for Ecology and Natural Resources, 1992.

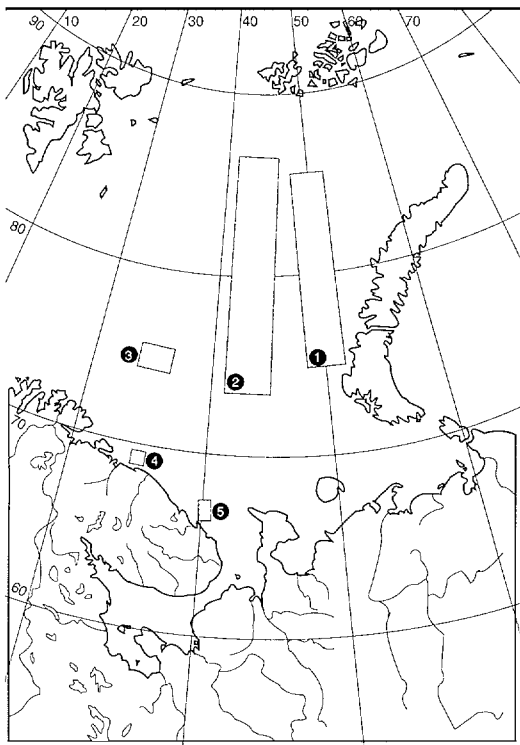

Until 1991, the Northern Fleet used service ships of this class to dump liquid radioactive waste at five different dumping areas in the Barents Sea, see map above.

Individual vessels

Northern Fleet:

TNT-8. Decommissioned.²⁷⁹

TNT-12. Ship normally based at naval yard no.10. Shkval in Polyarny.²⁸⁰

TNT-19.

TNT-25 Ship based in Severodvinsk.²⁸¹ It has an increased storage capacity for a total of 950 m³.

TNT-29.

Pacific Fleet:²⁸²

TNT-5. Ship based at Bolshoy Kamen, Vladivostok.²⁸³

In November 1995, liquid radioactive waste amounting to 800 m³ was transferred to TNT-27.²⁸⁴

TNT-17.

TNT-27. Ship based at Bolshoy Kamen, Vladivostok.²⁸⁵ It is in very poor condition.²⁸⁶

TNT-42

Additionally, two TNT type ships were dumped in the Kara sea in 1973 and 1980. Both had the designation TNT-15²⁸⁷ and are either of the Project 1783 A - Vala class or the slightly older Zeya class of storage ships.

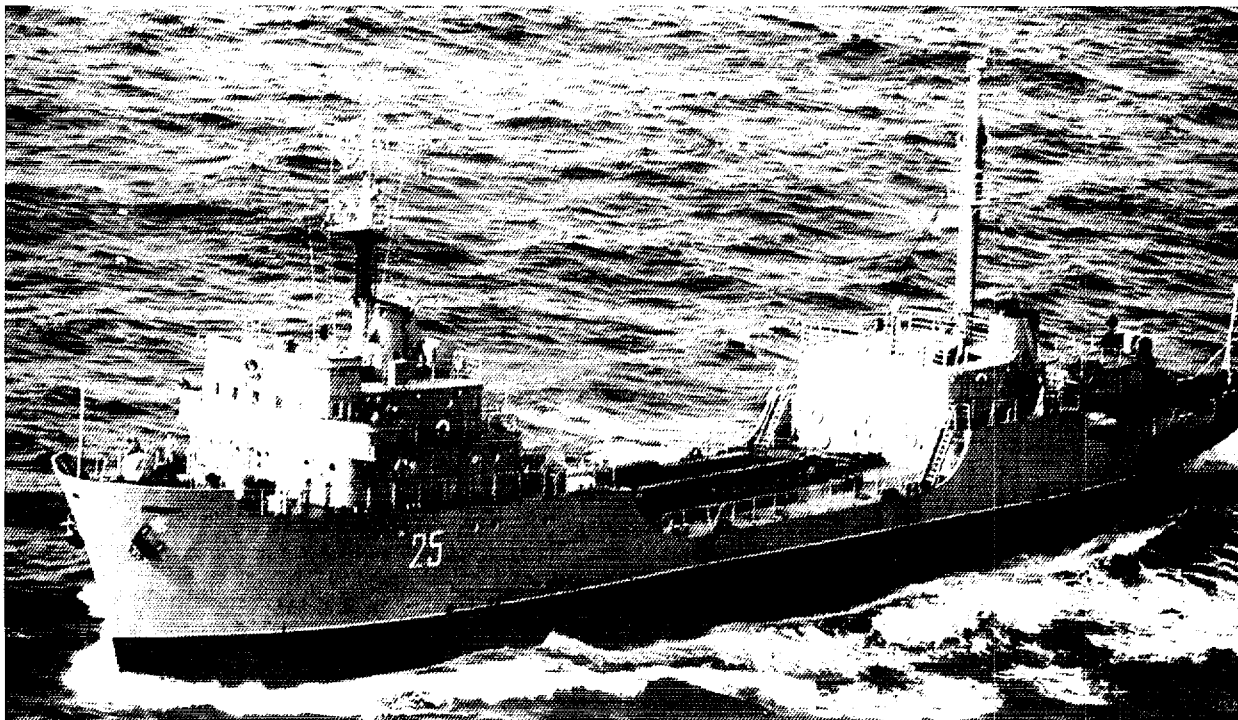

279 Mormul, N. Note, 1995.

280 *Jane's Intelligence Review*, December 1993.

281 Perovsky, V. A., Handbook presented to the Murmansk County Committee for Ecology and Natural Resources, 1992.

282 Handler, J., Greenpeace, *Radioactive Waste Situation in the Russian Pacific Fleet, Nuclear Waste Disposal Problems, Submarine Decommissioning, Submarine Safety, and Security of Naval Fuel*, P. 35, October 27, 1994.

283 Office of Technology Assessment, *Nuclear Waste in the Arctic. An Analysis of Arctic and Other Regional Impacts from Soviet Nuclear Contamination*, 1995.

284 *Nuclear Engineering International*, No. 1. - 1996.

285 Office of Technology Assessment, *Nuclear Waste in the Arctic. An Analysis of Arctic and Other Regional Impacts from Soviet Nuclear Contamination*, 1995.

286 *Nuclear Engineering International*, No. 1. - 1996.

287 Nilsen, T., and Bøhmer, N., *Sources of Radioactive Contamination in Murmansk and Arkhangelsk Counties*. Bellona Report No.1 :1994, P. 100.

Project 11510 - Belyanka class

The two ships of the Belyanka class, *Amur* and *Pinega*, were built to receive, transport and store liquid and solid radioactive waste. The ships are equipped with a special filter to reduce the radioactive content of liquid waste. They were formerly used to dump radioactive waste at sea.

Number: 2²⁸⁸

	Northern Fleet	Pacific Fleet	Total
In service	1	1	2
Inactive	0	0	0
Dismantled	0	0	0

Technical data²⁸⁹

Length: 123.3 m Displacement: 8 400 tons
 Beam: 17.1 m Crew: 90
 Draught loaded: 6.3 m Speed: approximately 16 knots
 Both ships of this class were built in Vyborg.

Storage capacity²⁹⁰

Each ship has a storage capacity of 800 m³ of liquid radioactive waste. The liquid is filtered through a special filtering installation on board the vessel. The design criteria is to reduce the radioactive content by a factor of one thousand. The filter can process 120 tons of liquid waste per day; however, the filter plant has never satisfied the design criteria with regard to reduction of radioactive content. The maximum permissible activity is set at 370 MBq/l–370 kBq/l

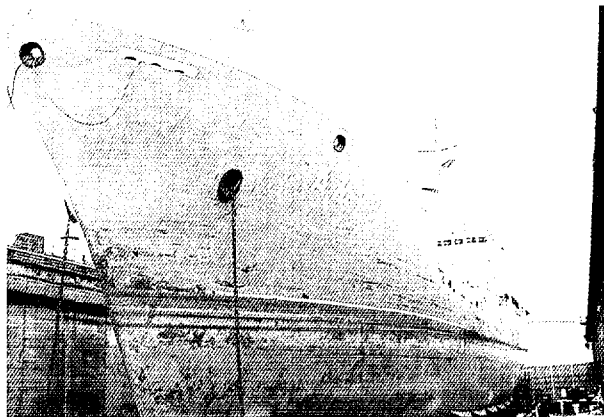

The Northern Fleet took *Amur* into use in 1984 and the vessel was comprehensively overhauled in 1993/94. Here *Amur* is pictured lying in dry dock in the central harbour at Murmansk.

(10⁻²–10⁻⁵ Ci/l). Each vessel also has two holds for the storage of solid radioactive waste.

One hold has a capacity of 600 tons of waste loaded in containers; while the other can accommodate 400 tons. The waste may be of varying activity and physical dimensions.

Compartments

- 1: Purification plant for liquid radioactive waste.
- 2: Holds for solid radioactive waste.
- 3: Storage tanks for liquid waste.
- 4: Power plant.
- 5: VRSh-room.
- 6: PEZh.
- 7: Auxilliary power plant.
- 8: Accommodation and controls.

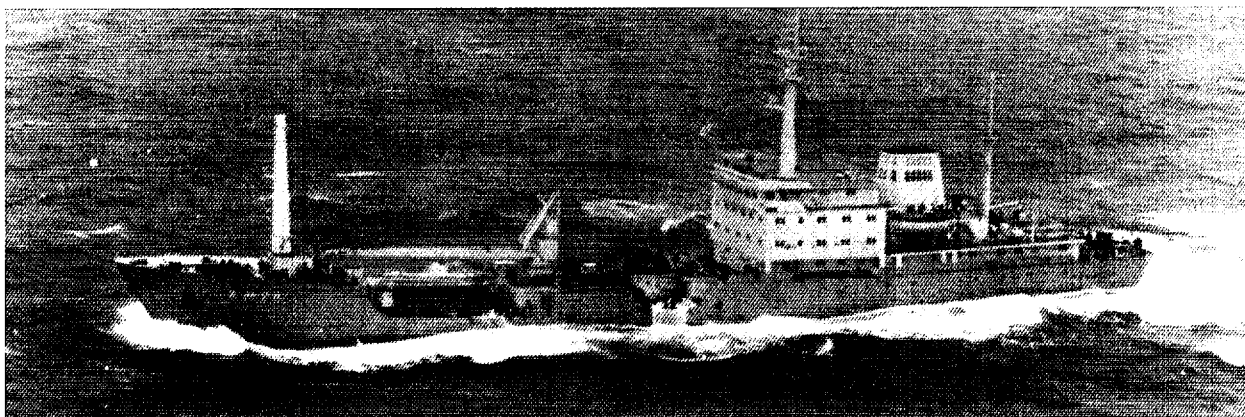

288 Pavlov, A. S., *Military Vessels in the Soviet Union and Russia 1945 - 1995*, 1994.

289 *ibid.*

290 Promotional leaflet on the ship, presented by the TsKB Institute, Aisberg.

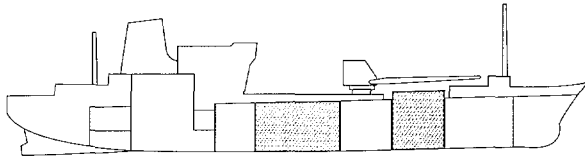

Project 11510

Individual ships²⁹¹

Amur. Commissioned to the Northern Fleet on November 29, 1984. Refitted in 1993/94 at the Nerpa shipyards.

Pinega. Commissioned to the Pacific Fleet on July 17, 1987.

Osetiya

This vessel is a civilian tanker stationed at the Zvezdochka shipyard in Severodvinsk. The tanker was built in 1963. In 1990, her tanks underwent repair, but following an inspection on August 12, 1990, the decision was made to lay her up. She is presently at a permanent mooring.²⁹²

Technical data

Length: Displacement:
Beam: Crew:

Storage capacity

Nine tanks with a total volume of 1 033 m³.

3.2

Service ships for spent nuclear fuel

Service ships play an important part in the refuelling of nuclear submarines. During refuelling operations, the submarine is usually placed between the service ship and the quay side. Derricks on the service ship are used to remove the spent nuclear fuel and to replace it with fresh fuel elements. (See Chapter 7 for a discussion on the handling and transportation of spent fuel.) The Northern Fleet operates six vessels in two classes for this purpose, the Project 2020 - Malina class and the Project 326/326 M class.²⁹³ The vessels of Project 326 are the oldest (more than 30 years) most run down of the service ships. The navy prefers to use the two ships of the Malina class when refuelling the nuclear submarines, but even these have technical deficiencies.²⁹⁴ One of the Northern Fleet Malina class ships cannot be certified until repairs have been made, but the ship remains in active service despite this.²⁹⁵ Nor are any of the four Project 326 M class ships certified, but these too are presently loaded with spent nuclear fuel.²⁹⁶

The rebuilt freighter *Severka* was originally used for the transportation and storage of spent nuclear fuel.²⁹⁷ In the 1960s, design work was commenced on the Bulba class ship which was capable of undertaking refuelling operations at sea. One ship of this type was built and tested in Severodvinsk, but the test results were disappointing. Subsequently, further work on the project was dropped.²⁹⁸

291 Pavlov, A. S., *Naval Craft of Russia and the Soviet Union 1945-1995*, 1994.

292 Handbook *On implementation plan for handling of nuclear waste and spent fuel on Severodvinsk territory*, summer 1994.

293 Perovsky, V. A., Handbook presented to the Murmansk County Committee for Ecology and Natural Resources, 1992.

294 Office of Technology Assessment, *Nuclear Waste in the Arctic: An Analysis of Arctic and Other Regional Impacts from Soviet Nuclear Contamination*, 1995.

295 Documentation of Gosatomnadzor inspection, November, 1993.

296 Kvaerner Moss Technology AS, *Disposal of Nuclear Submarines*, January 19, 1996.

297 Perovsky, V. A., Handbook presented to the Murmansk County committee for Ecology and Natural Resources, 1992.

298 Osipenko, L., Shiltsov, L. and Mormul, N., *Atomnaya Podvodnaya Epopeya*, 1994.

Project 2020 - Malina class

Number: 3

	Northern Fleet	Pacific Fleet	Total
In service	2	1	3
Inactive	0	0	0
Decommissioned	0	0	0

Technical data

Length: 136 m Displacement: 14.000 tons
 Beam: 22 m Crew: 260
 Draught: 5 m Speed: 17 knots

Construction yard

The three existing Malina class ships were designed by the Aisberg construction company in St. Petersburg and built at the Nikolaev shipyards on the Black Sea from 1984 to 1991. The Pacific Fleet ordered a fourth ship of this class, but the dissolution of the Soviet Union prevented delivery. The

Nikolaev yards are situated in what is now the state of Ukraine.

Storage capacity

Storage for 1 400 fuel assemblies amounting to approximately six reactor cores. The reactor cores are divided into four storage compartments, each with facilities for 51 containers of fuel assemblies. There are also two storage compartments for fresh nuclear fuel. Each ship has two derricks with a lifting capacity of 15 tons. Spent nuclear fuel can be hoisted directly aboard from the submarine reactors, or from barges of the 326 M type. The vessels are also equipped with storage tanks to hold 450 m³ of liquid radioactive waste including 95 m³ of medium level waste with an activity of up to 3.7 GBq/l (0.1 Ci/l).²⁹⁹



²⁹⁹ Nilsen, T., and Bøhmer, N., *Sources of Radioactive Contamination in Murmansk and Arkhangelsk Counties*. Bellona Report No.1 :1994, p. 56.

Individual ships

Northern Fleet :

PM-63. Entered service in October 1984 and is presently based in Severodvinsk.³⁰⁰

PM-12. Entered service in 1991 and is based at Olenya Bay at the Gadzhievo naval base.³⁰¹ In September 1991, two reactor cores were transferred from a third generation submarine to one of the holds. (The holds of these special tankers are not designed for the storage or transportation of this type of fuel.) On September 8, 1993, by accident some members of the ship's crew were exposed to undue levels of radiation. The reason for the accident is not known. A decision was made to temporarily take the vessel out of service. However this was never done, and in November of 1993, it received another consignment of spent nuclear fuel.

The tanker also has an onboard purification plant for processing liquid radioactive waste from primary cooling circuits. However, this installation has never functioned properly and the tanker continues to deliver liquid waste with an activity of 12 kBq/l (3.2×10^{-7} Ci/l) to shore bases. The ship also stores 400 tons of oil/water mixture in a way such that the stability of the vessel itself is compromised.³⁰²

Pacific Fleet:

PM-74. Commissioned in 1986 and used for refuelling operations and the transport of spent nuclear fuel to the Pacific Fleet storage facilities in Kamchatka and Shkotovo.³⁰³



300 Handbook *On implementation plan for handling of nuclear waste and spent fuel on Severodvinsk territory*, Summer 1994.

301 *Jane's Intelligence Review*, December 1993.

302 Documentation of a Gosatomnadzor inspection, November 1993.

303 Handler, J., Greenpeace, *Radioactive Waste Situation in the Russian Pacific Fleet, Nuclear Waste Disposal Problems, Submarine Decommissioning, Submarine Safety, and Security of Naval Fuel*, October 27, 1994.

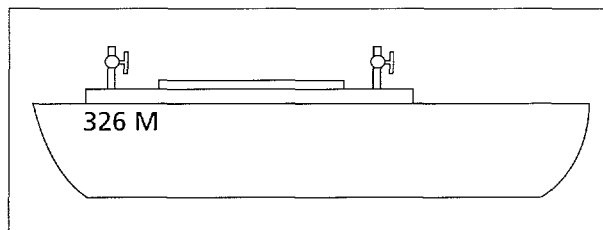

Project 326 - 326 M

Number: 8 (of which 2 are Project 326)

	Northern Fleet	Pacific Fleet	Total
In service	4	4	8
Inactive	0	0	0
Dismantled	0	0	0

Technical data³⁰⁴

Length: 90 m Displacement: 4 000 tons
 Beam: 8 m Crew: 56
 Draught: 4 m

Construction yard:

PM-50, PM-78, PM-124 and PM-128 were built in Severodvinsk from 1960 to 1966. The remaining four ships are refitted Finnish freighters. Refitting work was probably undertaken in Severodvinsk. The minimum age of these vessels is 30 years.³⁰⁵

Storage capacity

There are four storage compartments capable of holding 80 containers for a total of 560 fuel assemblies. This amounts to three reactor cores.

On barges of the 326 type, each fuel assembly is stored separately, whereas the upgraded 326 M type barges can store 5 to 7 fuel assemblies in each container. The designation 326 M is given to those barges which have been refitted to accommodate several fuel elements in each container.

The vessels also contain three storage tanks for liquid radioactive waste. One tank has a volume of 125 m³ and is intended for waste of medium to low activity. The two remaining tanks of 75 and 30 m³ respectively, are meant for highly active waste with an activity of 370 MBq/l (10⁻² Ci/l).

Individual vessels

Northern Fleet:

PM-50. This barge is based at Olenya Bay. Due to the elevated level of radiation in the storage tanks, it has been proposed to remove PM-50 from service. However, this has not been done despite the danger of continuing to use the vessel for transporting spent nuclear fuel.³⁰⁶ The equipment for monitoring shipboard levels of radiation is not functioning.³⁰⁷ The repair work which was commenced in 1993 has still not been completed.

PM-78. Based at Olenya Bay.³⁰⁸

PM-124. Moored at Zvezdochka shipyard in Severodvinsk.³⁰⁹

PM-128. The barge is based at Olenya Bay.³¹⁰

Pacific Fleet:³¹¹

PM-48. Built in 1960. Based at the Rybachky naval base in Kamchatka. Inactive.

PM-124. Built in 1962. Based at the Rybachky naval base in Kamchatka. Inactive.

PM-80. Built in 1964. Type 326 barge, based at Primorye. Inactive.

PM-42. Built in 1966. Type 326 barge, based at Rybachky base in Kamchatka.

304 Perovsky, V. A., Handbook presented to the Murmansk County Committee for Ecology and Natural Resources, 1992.

305 Office of Technology Assessment, *Nuclear Waste in the Arctic. An Analysis of Arctic and Other Regional Impacts from Soviet Nuclear Contamination*, 1995.

306 Documentation of a Gosatomnadzor inspection, 1994.

307 *ibid.*

308 *Jane's Intelligence Review*, December 1993.

309 Handbook *On implementation plan for handling of nuclear waste and spent fuel on Severodvinsk territory*, Summer 1994.

310 *Jane's Intelligence Review*, December 1993.

311 Office of Technology Assessment, *Nuclear Waste in the Arctic. An Analysis of Arctic and Other Regional Impacts from Soviet Nuclear Contamination*, 1995.

Severka

This ship was used to transport spent nuclear fuel from the storage facility at Andreeva Bay to the embarkation point for rail transport in Rosta, Murmansk. It had a civilian crew. The vessel has been laid up since 1993, but the nuclear fuel is still on board.³¹²

Technical data

Length: Displacement: 1 800 tons:
 Beam: Crew:
 Speed:

Construction yard

Severka was built in 1957 in Hungary as a river freighter prior to being transferred to the Northern Fleet in the 1960s. In 1978, it was refitted at the Navy yard at Sevmorput to transport spent nuclear fuel.³¹³

Storage capacity

The ship has two storage tanks with a total storage capacity of 88 type TK-11 storage containers.³¹⁴

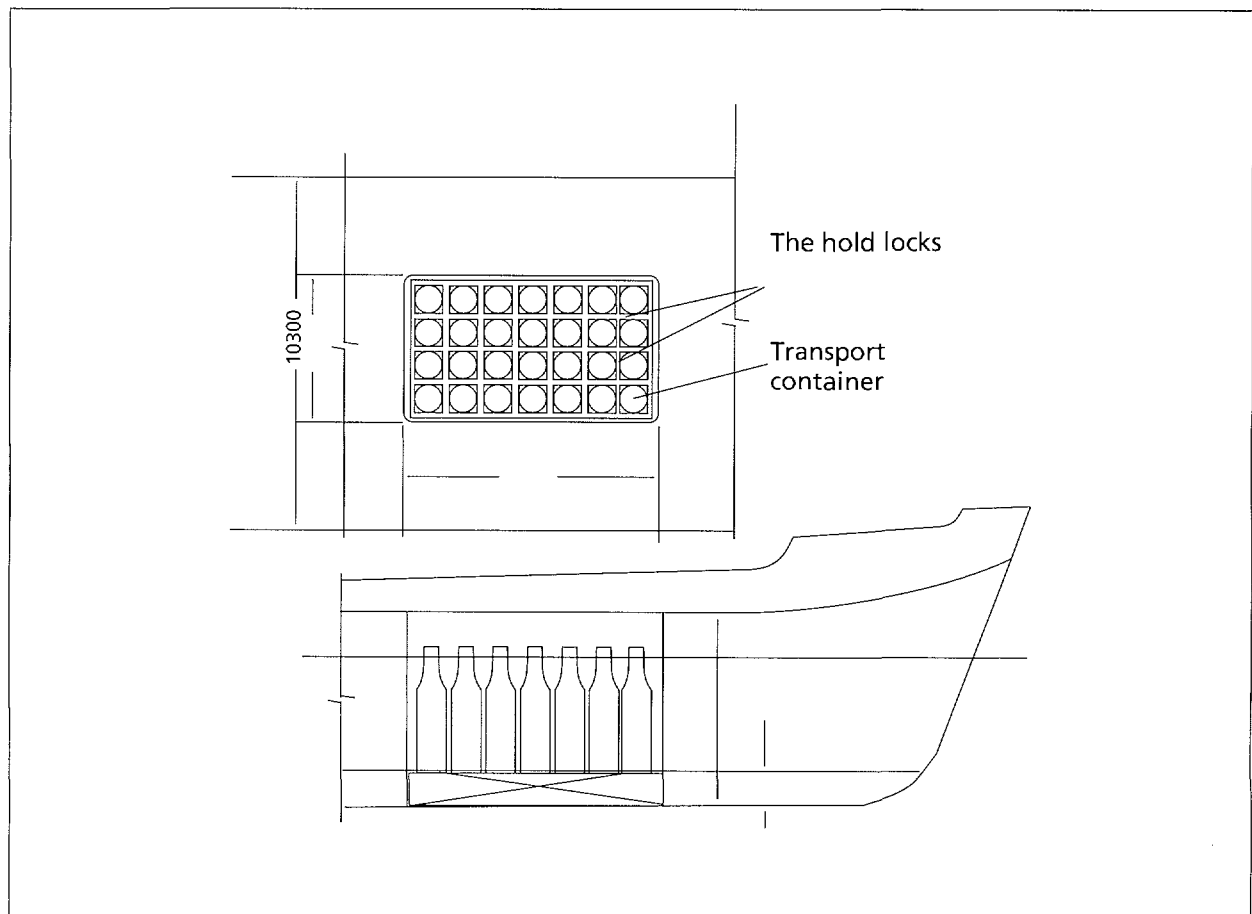

Storage methods on board Severka

312 Meeting with Gosatomnadzor, Murmansk 1995.

313 Perovsky, V. A., Handbook presented to the Murmansk County Committee for Ecology and Natural Resources, 1992.

314 Ibid.

Radioactive waste at the naval bases



Radioactive waste at the naval bases

The nuclear-powered ships of the Northern Fleet operate from five naval bases on the Kola Peninsula: Zapadnaya Litsa, Vidyaevo, Gadzhievo, Severomorsk and Gremikha. Some of these bases also have additional facilities such that there is a total of seven base sites for operational nuclear vessels. There are land-based storage facilities for spent fuel assemblies at two of these bases. Solid and liquid radioactive waste are stored at six of the bases. Furthermore, there are a number of technical service ships containing spent fuel assemblies and solid or liquid radioactive waste that serve the naval bases and shipyards. These service ships are described in chapter 3. In addition, considerable amounts of radioactive waste have been stored at Kola Peninsula shipyards and in Severodvinsk. The nuclear submarines taken out of service are located at these shipyards. The shipyards are described in Chapter 5.

In the following we will briefly examine the development of the naval bases and the generation of radioactive waste and spent nuclear fuel, and give a short description of each of the naval bases. When we describe the bases, the number and classes of the nuclear submarines that are normally stationed at the base, are given. The numbers may vary over time, since the submarines often change bases at the completion of a tour of duty.

4.1

The development of naval bases³¹⁵

The two primary reasons for the construction of naval bases on the Kola Peninsula were the proximity to the Atlantic Ocean and the country's need for access to ice-free harbours. Most of the area bases were built after the Second World War, and during the Cold War, the development and construction of nuclear submarines and various missile systems received the highest priority. However, the development of infrastructure at the bases

along with service functions and shipyards for the nuclear submarines lagged behind the rate at which the vessels themselves and their immediate requirements were being built. Often there was a lapse of five to eight years from the time that the new submarines were launched before technical facilities for the servicing and maintenance of these vessels were ready for use. The first nuclear submarine of the Soviet Northern Fleet (K-3) was launched in 1958³¹⁶, yet the first facilities for the handling of radioactive waste and spent nuclear fuel were not ready for use until the early 1960s.³¹⁷ Also the later classes have had such problems. At the Nerpichya naval base, a number of the docking facilities for the Typhoon class submarines remain incomplete, for the cranes which were to have been built at the pier were never erected. Yet the first Typhoon class submarine was launched in 1981.³¹⁸

A number of facilities for the handling and treatment of radioactive waste exist on the drawing board, and construction was started on many of them. However, many of these projects were never completed. At Andreeva Bay, construction was started on a facility for the processing of liquid radioactive waste, but the work was never completed. In another instance, a loading facility for spent nuclear fuel intended for the same base never proceeded beyond the planning stage. The safe handling and treatment of radioactive waste is not highly prioritised, and this is reflected in the lack of technical and economic resources that are earmarked specifically for this purpose. The facilities that actually have been built have been financed with whatever funds remained once the operational Navy forces had been served.

The location of the respective bases was determined by the pertinent military authorities, whereas the actual decision to build any given base was adopted by resolution in the Central Committee of the Communist Party and by the government. Timely completion of a particular facility was more important to the Central Committee in Moscow than the standard of the buildings and the quality of the equipment.

315 Unless otherwise stated, the information in this chapter is from Nilsen, T., and Bøhmer, N., *Sources of Radioactive Contamination in Murmansk and Arkhangelsk Counties*, Bellona Report No. 1 1994.

316 *Morskoy sbornik* (The Navy Handbook), No.1, 1995.

317 Mormul, N. Note, 1995.

318 Pavlov, A. S., *Military Vessels in the Soviet Union and Russia 1946-1995*, 1994.

The naval bases on the Kola Peninsula were built by military personnel who lacked the skills and competence necessary to construct sound and solid buildings in the hard climatic conditions of the north. The personnel were poorly trained for the task at hand and a low level of discipline was reflected in the poor quality of the buildings that the military building battalions erected. Conscripts who were not qualified to serve in the fighting forces were transferred to working on military construction projects. The commissions responsible for approving the various projects at the bases were largely military commissions, and the commanding officer's chief responsibility was to ensure that deadlines for the construction projects were met.

Under these conditions, it is plain that concern for the environment or the safety of the population was not of high priority. In the beginning there were no defined limits to confine possibly harmful consequences to the environment posed by the various nuclear facilities and storage areas.³¹⁹ Nor were there any set limits to the amount of radiation workers at the facilities might be exposed to. The future possibility of having to dismantle nuclear submarines and clear up the storage areas was never considered. The introduction of simple radiation safety rules was but a small improvement. Rules with respect to public health and other standard documents were kept secret and remained unavailable to both the public and the pertinent monitoring agencies. Local authorities were never informed of activities taking place inside the naval bases and nuclear submarine yards. To this day, the Russian state radiation protection authority (*Gosatombnadzor*) is denied access to information about the activities of the Northern Fleet. In 1994, an attempt was made to open up the naval bases so that civilian monitoring agencies could evaluate radiation safety. This was accomplished when President Boris Yeltsin signed a decree assigning *Gosatombnadzor* the responsibility to monitor radiation safety at the naval bases.³²⁰ Despite the President's instructions, the navy refused to allow representatives from *Gosatombnadzor* to enter the naval bases.³²¹ In 1993, the Northern Fleet denied a request of the local Committee on the Environment in Murmansk for information on the storage of radioactive waste at the naval bases on the Kola Peninsula.³²² In spring 1995, the committee was permitted to visit the facilities at Andreeva Bay. At present, the Ministry of Defence has direct responsibility for control of the storage of spent nuclear fuel and radioactive waste at the naval bases and installations.³²³

It is clear that those who built the nuclear submarines and established the processing facilities for radioactive waste were unable to foresee the magnitude of the problems that would arise with respect to the storage of radioactive waste and the decommissioning of nuclear submarines.

4.2

Generation of radioactive waste and spent nuclear fuel

The use, maintenance and decommissioning of nuclear reactors generate radioactive waste which in turn must be processed, transported and stored. During normal operation, radioactive waste and spent nuclear fuel are generated largely during the refuelling of the submarine reactors. Earlier Russian submarines were generally refuelled after a period of seven to ten years of service, depending on the enrichment of ²³⁵U and the use of the reactor. Nowadays the Russian nuclear submarines are refuelled after three to five years of operation.³²⁴ Since the 1980s, spent nuclear fuel has been removed from some of the Northern Fleet's laid up submarines.

Earlier the reactors were refuelled while the submarines were in dry-dock. In recent years it has become common practice to refuel the reactors while the submarines are floating between a pier and one of the service ships for spent nuclear fuel. Refuelling operations are both time consuming and hazardous. Russian submarine reactors are left to cool for a minimum of 90 days after shutdown before work to remove the spent nuclear fuel begins.³²⁵ The operation to remove the fuel takes about one month, while it takes two to three months to place fresh fuel in the reactor and ready reactor for operation.³²⁶

The process of changing fuel in a reactor starts by cutting away the part of the hull that covers the reactor. Some remedial action is taken to prevent release of radioactive dust. The primary cooling circuit is disconnected, and the fuel assemblies are lifted out singly. The service ship derricks are used for this operation. The fuel assemblies are placed in special metal containers and hoisted to the service ship holds. When all the assemblies are removed, overhaul and repair of the reactor is carried out. New fuel assemblies are inserted, and the primary cooling circuits

319 *Atomnaya Energiya* Vol. 76, 2nd edition, 1994.

320 Decree from the Russian President, June 5, 1995.

321 Conversations with the director of *Gosatombnadzor* in Northwest Russia—St. Petersburg, January 1995 and *Yaderny Kontrol*, May 17, 1996.

322 Nilsen, T., and Böhmer, N., *Sources of Radioactive Contamination in Murmansk and Arkhangelsk Counties*, Bellona Report No. 1 1994.

323 *Nezavisimaya Gazeta*, October 31, 1995.

324 Office of Technology Assessment, *Nuclear Waste in the Arctic. An Analysis of Arctic and Other Regional Impacts from Soviet Nuclear Contamination*, 1995.

325 Nilsen, T., and Böhmer, N., *Sources of Radioactive Contamination in Murmansk and Arkhangelsk Counties*, Bellona Report No. 1 1994.

326 Office of Technology Assessment, *Nuclear Waste in the Arctic. An Analysis of Arctic and Other Regional Impacts from Soviet Nuclear Contamination*, 1995.

are filled with new coolant. The reactor lid is fastened, and the removed section of the hull is welded into place.³²⁷

About 10 m³ of high level liquid radioactive waste are generated during refuelling operations. In addition, solid wastes are generated such as control rods, tailings from the reactor tank and other equipment that has been contaminated during work. The replacement of various reactor filters leads to the generation of about 1 m³ of highly radioactive ion exchange sorbent. The procedure results in an accumulation of 2-3 m³ of liquid radioactive waste. The larger reactor parts, that are exchanged during refuelling, must also be regarded as radioactive waste. Under normal circumstances, a refuelling operation generates between 155 to 200 m³ waste.³²⁸

A considerable amount of the radioactive waste stored by the Northern Fleet comes from the repair of nuclear submarines that have been damaged in accidents of varying degrees of severity. Such accidents tend to occur particularly during refuelling of the submarines. One problem frequently encountered is that the fuel assemblies crack while the reactor is in operation. As a result, the fuel assemblies must be replaced even more frequently. The present procedure for the treatment and handling of radioactive waste was introduced from the very outset of the Russian nuclear submarine programme and is outlined below:³²⁹

1. Removal of the spent fuel assemblies from the reactors and transfer to storage compartments on board the Northern Fleet type 326 service ship *Severka*, and at a later date, to type 2020 ships in the Malina class.
2. Temporary storage of the spent fuel assemblies on board these service ships. Eventual transport to land-based storage facilities owned by the Northern Fleet at Andreeva Bay (formerly also at Gremikha).
3. Temporary storage of the spent fuel assemblies at these facilities for three years.
4. Transfer of the fuel assemblies back to Northern Fleet service ships for transport to naval shipyard No. 35 Sevmorput at Rosta in Murmansk. The fuel assemblies are then conveyed to the adjacent railway yards and transported to Sevmorput.
5. Re-loading of the fuel assemblies into transport containers for forwarding to Mayak.
6. Storage and eventual reprocessing at Mayak.

There is a considerable amount of transport of spent fuel assemblies between the various naval bases on the Kola Peninsula. Transport procedures and handling of spent nuclear fuel is discussed more fully in Chapter 7.

Presently somewhat in excess of 7 000 m³ liquid, low to medium activity waste, with a total activity of 3,7 TBq (100 Ci) is stored at Northern Fleet naval bases and

yards.³³⁰ In addition comes the high activity waste. Liquid waste is stored in floating tanks, in tanks on shore and aboard service ships and tenders. The yearly production of liquid waste is between 2 000-2 500 m³. Since all storage capacity on the Kola peninsula is full, the situation has become acute. Some liquid waste is taken to be processed the Atomflot treatment plant in the Murmansk fjord. In 1994 the Northern Fleet delivered 1 000 m³ here and in 1995, 200 m³. Even if Atomflot treatment capacity should increase, the Northern Fleet will have difficulty in footing the bill for treatment and transport.³³¹

There is now approximately 8 000 m³ of solid nuclear waste of low to medium activity in storage at Northern Fleet bases and yards. Total activity for the waste is about 37 TBq (1000 Ci).³³² The solid waste is stored in concrete installations, on ships and in the open. The yearly production of solid waste is about 1 000 m³. The annual waste production will increase significantly as decommissioning gathers momentum. The Northern Fleet has no installations for the treatment of solid waste. Those types of waste which could have been burnt or compressed are now occupying an undue amount of storage space.

The storage of control rods from submarine reactors is of great concern. The rods, made of a boron-europium alloy, are used for controlling reactor output. They are renewed simultaneously with the fuel elements. Used control rods are highly radioactive, but they are stored together with low to medium activity solid waste. At the present time, several thousand such rods are stored in Northern Fleet bases and yards.³³³

4.2.1 Risk Assessments

It is hardly possible to perform a risk assessment of the various vessels and installations of the Northern Fleet on the basis of the information that is presented in this report. A serious assessment of the risk of accidents occurring at the nuclear installations or of leaks from the storage facilities would require a thorough technical examination of the facilities under discussion as well as knowledge about how they are operated. The previous chapters have described the various naval bases and focused on presenting an overview of the actual number of nuclear submarines and the amount of radioactive waste and spent nuclear fuel that they generate.

Using purely physical criteria, the degree of danger presented by the items under study can roughly be divided into two categories:

- Risk of uncontrolled chain reactions. This applies to operational nuclear submarines, decommissioned

327 Nilsen, T., and Böhmer, N., *Sources of Radioactive Contamination in Murmansk and Arkhangelsk Counties*, Bellona Report No. 1 1994.

328 Office of Technology Assessment, *Nuclear Waste in the Arctic. An Analysis of Arctic and Other Regional Impacts from Soviet Nuclear Contamination*, 1995.

329 Document from the locale Gosatomnadzor (V. Dimitrev), Severodvinsk Environmental Committee (M. Dailov) and Control Committee for Objects under the control of The Ministry of Defence (A. Gordienko), 1995.

330 Petrov, O., *Radioactive Waste and Spent Nuclear Fuel in the Navy of Russia*, 1995.

331 Ibid.

332 Ibid.

333 Ibid.

Table 6: The items at the Northern Fleet naval bases representing a nuclear safety risk.

Naval base	Nuclear ships in operation	Inactive Submarines w/fuel	Stored fuel assemblies	Inactive submarines without fuel	Liquid Radioactive waste	Solid radioactive waste
Zapadnaya Litsa						
Bolshaya Lopatka	22	1		1	Yes	Yes
Nerpichya	6				Yes	Yes
Andreeva Bay			Max. 23 260		2 000 m ³	Min. 6 000 m ³
Vidyaevo	4	14			Min. 3 m ³	Yes
Gadzhievo						
Sayda Bay				12		
Gadzhievo	7	6			200 m ³	2 037m ³
Olenya	12					
Severomorsk	2					
Gremikha	Yes	15	795 + 9 reactor cores			

submarines whose nuclear fuel remains in the reactor, as well as storage facilities, storage ships and railroad containers holding spent nuclear fuel. It is in these kinds of accidents that the risk of releasing significant amounts of radioactivity over a large area is greatest.

- Danger of leaks of radioactivity from sources other than an uncontrolled chain reaction. This concerns potential leaks from submarine reactors, storage facilities for solid and liquid radioactive waste, transport ships, trains or lorries, as well as storage facilities for spent nuclear fuel.³³⁴

There are a number of possible causes of both uncontrolled chain reactions and radioactive leaks. The principal reasons include technical failure, fire, explosion, human error, wear and seismic or climatic incidents. A complete risk evaluation requires that all of these points are taken into account. The table below presents an overview of the items at the Northern Fleet naval bases that represent a nuclear safety risk.

4.3

Zapadnaya Litsa³³⁵

Zapadnaya Litsa is the largest and most important Russian naval base for nuclear-powered submarines. The base is located on the Litsa Fjord at the westernmost point of the Kola Peninsula, about 45 kilometres from

Map 2. Zapadnaya Litsa.

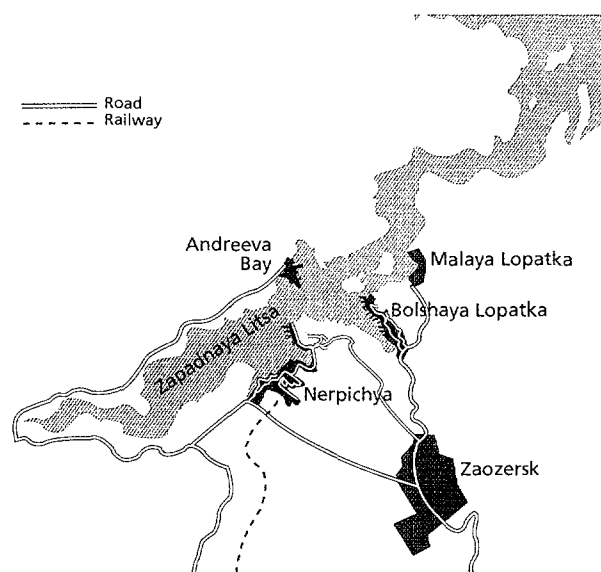

the Norwegian border. The Litsa Fjord heads into the Kola interior from the Motovsky Fjord, just across from the south-eastern coast of the Rybachky Peninsula. The residential city for the naval base facilities is called Zaozersk and is located six kilometres east of the inner reaches of the Litsa Fjord.³³⁶ Up until the beginning of the 1980s, the town was known as Severomorsk-7. It has also been called Murmansk-150 and Zaozerny. Zaozersk has a population of about 30 000, most of whom are navy personnel and their families. Construction of the town was started in 1959 at the same as the first naval facilities were built. The road to Zapadnaya Litsa turns

³³⁴ *Atomnaya Energiya*, Vol. 76, 2nd edition, 1994.

³³⁵ Unless otherwise stated, the information in this chapter is from Nilsen, T., and Böhmer, N., *Sources of Radioactive Contamination in Murmansk and Arkhangelsk Counties*, Bellona Report No. 1 1994.

³³⁶ *Krasnaya Zvezda, Typhoon under the North Pole*, 1995.

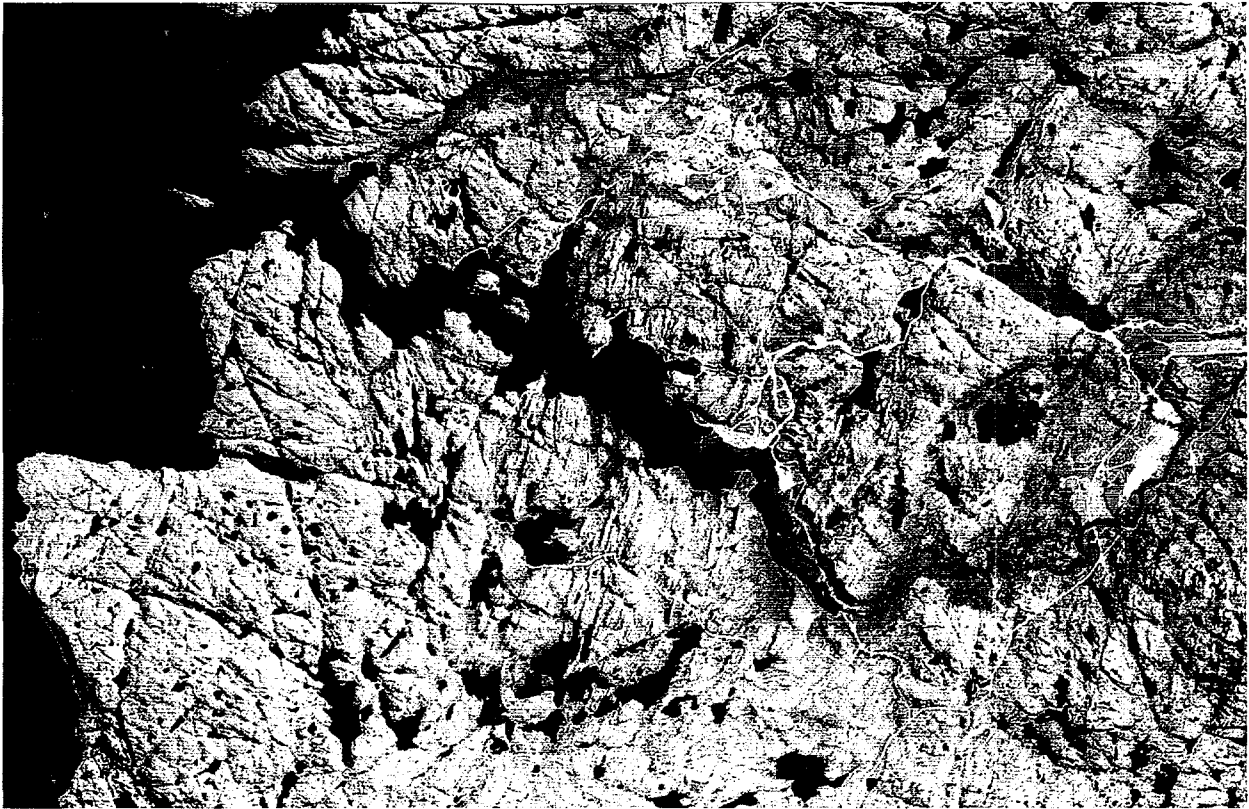

This satellite photograph of Zapanaya Litsa was taken in 1989. The Northern Fleet's largest intermediate storage facility for spent nuclear fuel may be seen on the western side of the fjord in Andreeva Bay. The three base facilities for nuclear submarines are also shown on the eastern side of the fjord. Zaozersk and the surrounding agricultural area may be seen to the right in the picture.

off from the highway between Murmansk and Nikel a few kilometres west of the River Litsa. Construction of a railroad track to the base was begun in the 1980s but never completed; however, the line does reach Nerpichya where the Typhoon class submarines are based.³³⁷

There are four naval facilities at Zapadnaya Litsa: Malaya Lopatka, Bolshaya Lopatka, Nerpichya and Andreeva Bay. Zapadnaya Litsa was expanded considerably towards the end of the 1970s and at the beginning of the 1980s. The total length of the base quays is 20 600 metres.³³⁸ Traditionally, the newest submarines have been deployed to Zapadnaya Litsa as soon as they are commissioned, and included among them are both attack submarines, strategic submarines and tactical submarines. The three Soviet research submarines of respectively, type 645 (K-27), type 661 - Papa class (K-162), and type 685 - Mike class (K-278 *Komsomolts*) have also been stationed here.

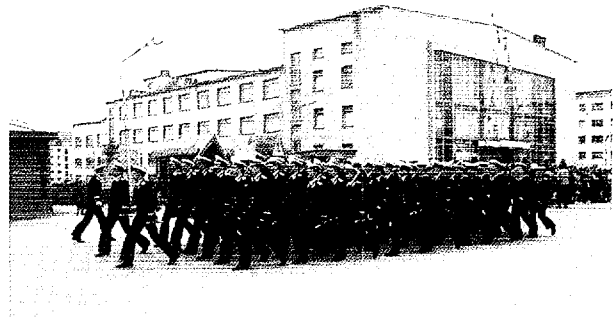

Zaozersk is a naval base town at Zapadnaya Litsa that is closed to the public. The town has about 30.000 inhabitants, most of whom are submarine crew and other military personnel along with their families.

4.3.1 Malaya Lopatka

Malaya Lopatka was the first base facility to be built at Zapadnaya Litsa at the end of the 1950s. From the summer of 1958, the Soviet Union's first nuclear submarine, K-3, was stationed here. During the following year, the first group of nuclear submarines consisting of K-5, K-8, and K-14 was based at Malaya Lopatka.³³⁹ At the end of the 1950s, Academician Aleksandrov was at Malaya Lopatka to personally direct the sea trials of the nuclear reactors for the first nuclear submarines.³⁴⁰ Construc-

337 Murmansk Vestnik, September 2, 1995.

338 Ries, T., and Skorve, J., *Investigating Kola: A Study of Military Bases Using Satellite Photography*, Oslo, 1987.

339 Osipenko, L., Shiltsov, L. M. and Mormul, N. G., *Atomnaya Podvodnaya Epopeya*, 1994.

340 Mormul, N. Note, 1995..

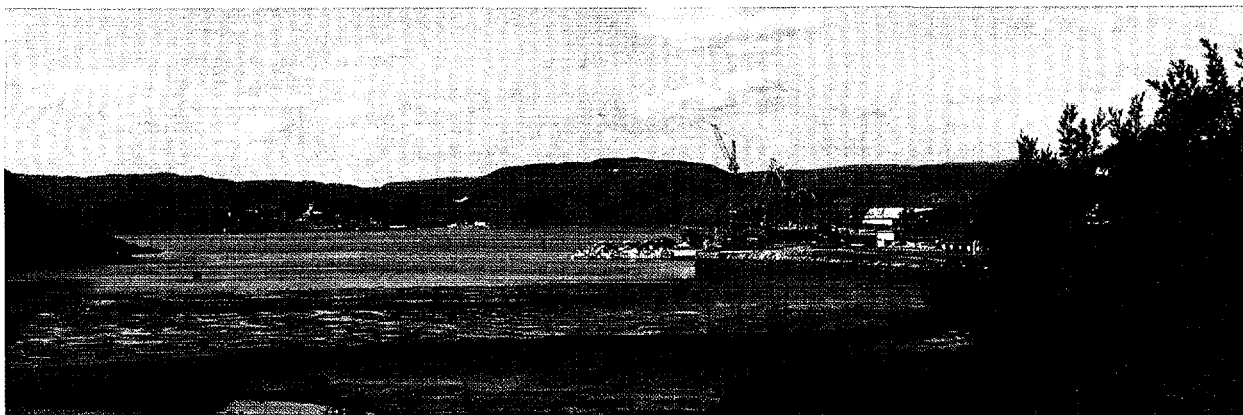

Nuclear submarines of the Victor, Alfa and Oscar classes are stationed at the base facility in Bolshaya Lopatka. This facility is located on the eastern side of the Litsa Fjord, directly across from Andreeva Bay.



Nerpichya lies in the innermost reaches of the Litsa Fjord. The base facility also has a dry dock which is used for carrying out repairs on the Typhoon class submarines. There is also a smaller, temporary storage area for solid and liquid radioactive waste.

tion of the pier facilities was completed at Bolshaya Lopatka (another naval facility two kilometres further into the fjord) during the first half of the 1960s, and the nuclear submarines were subsequently transferred there. Malaya Lopatka was then used as a repair base, and today there are also five piers and a floating repair workshop here.³⁴¹

4.3.2 Bolshaya Lopatka

Bolshaya Lopatka was the second base facility to be built at Zapadnaya Litsa and is situated two kilometres further down the fjord. Most of the present day nuclear-powered submarines are stationed here. There also used to be some first generation nuclear submarines at this base, but now all of the vessels are of the second or third generation.³⁴² There is a total of 32 operational subma-

nes based at Bolshaya Lopatka³⁴³ plus two decommissioned submarines of type 705 - Alfa class (K-493 and K-373).³⁴⁴ The nuclear fuel of K-373 remains on board in the submarine's reactor. A third submarine of this type, K-123, also based at Bolshaya Lopatka, is still in operation.³⁴⁵ Other submarines at the base include two nuclear submarines of type 949-Oscar-I class (K-525 and K-206) and six vessels of type 949 A-Oscar II class (K-148, K-119, K-410, K-266, K-186 and K-141). There are also nine nuclear submarines of type 671 RTM-Victor-III class. At least 11 submarines of type 671 R-Victor-I class and type 671 RT-Victor-II class are based at Bolshaya Lopatka, and the Northern Fleet's four nuclear submarines of the type 945 - Sierra class (*Barracuda*, *Condor*, *Carp* (K-239), and *Crab*, K-276)³⁴⁶ are also normally stationed here. *Barracuda* is presently in the docks at the Sevmash shipyard in Severodvinsk

341 Skorve, J., *The Kola Satellite Image Atlas*, P. 99, 1995.

342 *Jane's Intelligence Review*, December 1993.

343 International Institute for Strategic Studies, 1995 and own estimate.

344 Mormul, N. Note, 1995.

345 Pavlov, A. S., *Military Vessels in the Soviet Union and Russia 1945-1995*, 1994.

346 *Ibid.*

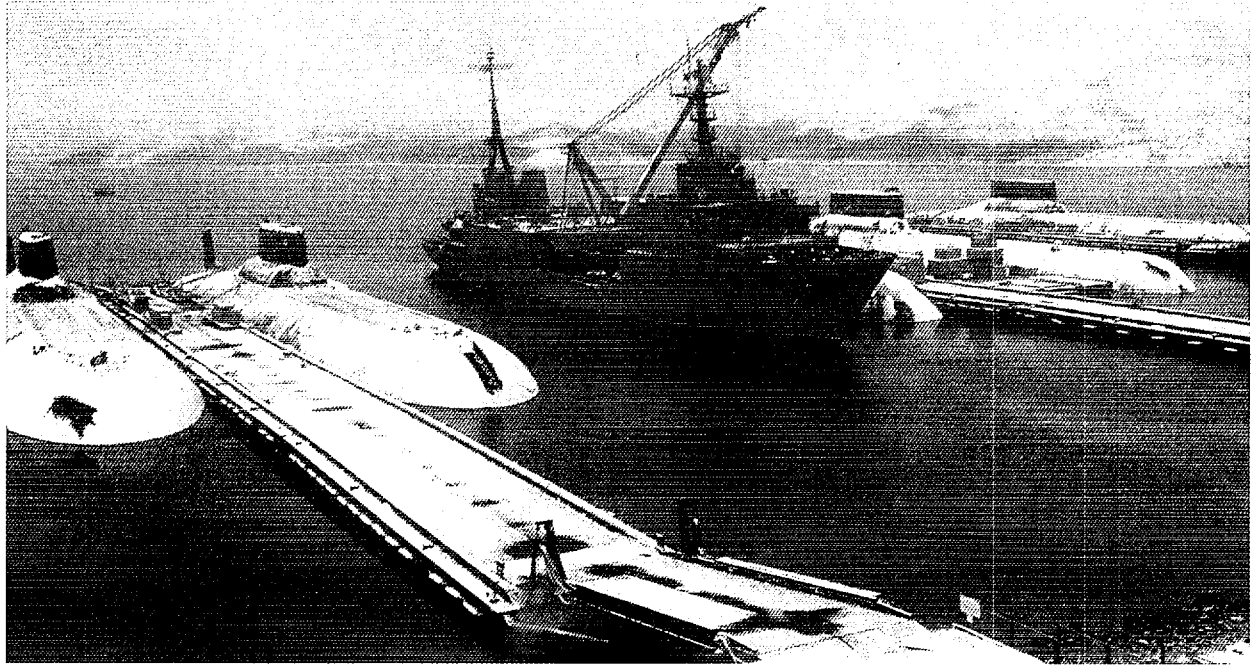

There are six Typhoon class nuclear submarines stationed at these three piers in Nerpichya. Each vessel carries 200 strategic nuclear warheads, such that when all of the submarines are in port, there is a total of 1200 nuclear warheads between them. The other military vessel at the pier facility is Aleksandr Brykin, a transport ship for strategic nuclear missiles which can be transferred at sea onto the Typhoon class submarines. The ship's storage room holds 16 missiles, each of which carries ten nuclear warheads.

where it is being rebuilt following its collision on February 11, 1992 with the American nuclear submarine *Baton Rouge* just off Kildin Island near the Kola coast.

Bolshaya Lopatka also has 8 piers and a floating dock to service and repair nuclear submarines.³⁴⁷ The radiation protection authorities take samples of the water in the submarine reactor's primary circuit, and there is also a storage facility for sources of ionising radiation at this base. There is an additional smaller storage facility for the solid and liquid radioactive waste that is generated during the process of checking the cooling water. Once this intermediate storage area is filled, the waste is transferred to the large storage facility in Andreeva Bay right across from Bolshaya Lopatka on the other side of the Litsa Fjord. At this storage there is about 2 m³ solid radioactive waste.³⁴⁸

4.3.3 Nerpichya

Nerpichya, located at the inner reaches of the Litsa Fjord, is the newest of the Zapadnaya Litsa base facilities. The first pier facilities were ready for use by the end of the 1960s. When the base facility was opened, it served as a base for nuclear submarines of type 675–Echo-II class, and later, for submarines of type 658–Hotel class.³⁴⁹ In 1977, all of the nuclear subma-

nes were transferred to other naval bases on the Kola Peninsula, as Nerpichya was to be modified to become the naval base facility for the new giant 175 meter-long type 941 nuclear submarines–Typhoon class. Construction on the first submarine in this class was started in 1977.³⁵⁰ In the period from 1977 to 1981, the base facilities at Nerpichya were expanded to include three large piers and a number of new facilities on shore. However, despite the fact that the new nuclear submarines were to be based at Nerpichya, many of the new facilities were never completed. For example many of the parts necessary to complete a larger facility for external supply of energy to the submarines never arrived at Zapadnaya Litsa. Many of the cranes planned for the three new piers were never erected. Presently there are six nuclear submarines of the type 941 Typhoon class (TK-208, TK-202, TK-12, TK-13, TK-17 and TK-20) based at Nerpichya.³⁵¹ The three piers at which the submarines are moored are located beneath a steep mountain. In the early 1980s, there was a rock slide here which destroyed a number of buildings all the way down to the piers.

There is also a ship repair bay on shore and a large floating dock, as well as a land-based storage facility for radioactive sources and solid and liquid waste. Since the facility is quite small, the waste is transferred at regular intervals to Andreeva Bay.

347 Skorve, J., *The Kola Satellite Image Atlas*, P. 99, 1995.

348 Mormul, N. Note, 1995.

349 *Ibid.*

350 Pavlov, A. S., *Military Vessels in the Soviet Union and Russia 1946-1995*, 1994 and *Murmansky Vestnik*, September 2, 1995.

351 *Ibid.*



This is the Northern Fleet's largest storage facility for spent nuclear fuel assemblies, solid and liquid radioactive waste. The numbered points refer to the numbers in the text and on the map. Numerous leaks from these facilities have led to radioactive contamination of the fjord.

4.3.4. Andreeva Bay

Of the four naval facilities at Zapadnaya Litsa, Andreeva Bay is the only one at which no submarines are based. Andreeva Bay lies on the west side of the Litsa Fjord, five kilometres as the crow flies from Zaozersk. The base is served both by road and by ship. The Northern Fleet's largest storage facilities for radioactive waste and spent nuclear fuel are located here.³⁵² The facilities at Andreeva Bay cover an area of about two hectares. Its buildings and facilities are as follows:

1. Pier from which spent fuel is loaded from a service ship to a lorry.
 2. Quay facility, Building 32.
 3. Radiation protection unit for the monitoring and treatment of personnel working at the facilities, Building 50.
 4. Purification facility for liquid radioactive waste (never taken into use). Used today for other purposes.
 5. Storage pool for spent nuclear fuel, Building 5. The pool was emptied and taken out of use in 1989.
 6. Three large, partially buried concrete containers for dry storage of spent nuclear fuel.
 7. Crane for transfer operations of spent nuclear fuel.
 8. An enclosed area in which containers of spent nuclear fuel are stored.
 9. Concrete bunker divided into compartments and an open area in which solid radioactive waste is stored.
- Underground containers for the storage of liquid radioactive waste.

Map 3. Overview of the different installations in Andreeva Bay. The numbered points on the map refer to the numbers in the text and on the picture.

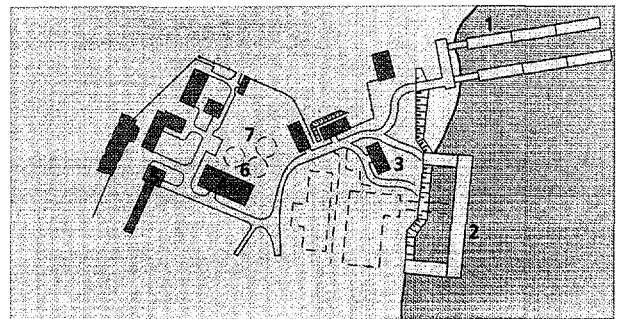

- Storage facility for fresh nuclear fuel, Building 34.
- Special decontamination unit for processing of contaminated equipment, Building 4.
- Building for decontamination of handling equipment for nuclear fuel (never taken into use).
- Storage area for handling equipment.

In addition, there is a diesel-fuelled power station, mechanical workshop, transformer station, storage for oil and diesel, and a dock facility. All of the buildings and facilities, with the exception of the concrete tanks for dry storage of spent nuclear fuel and their accompanying cranes, were built between 1960 and 1964. They are now in an exceedingly poor technical condition. In 1986 the Ministry of Defence decided to reconstruct the Andreeva Bay installations for treatment of nuclear waste. Suggesti-

352 Yemalenikov, A., and Popov, B., *Atom bez grifa sekretno* (Unconfidential Atoms), IPPNW, Moscow - Berlin 1992.

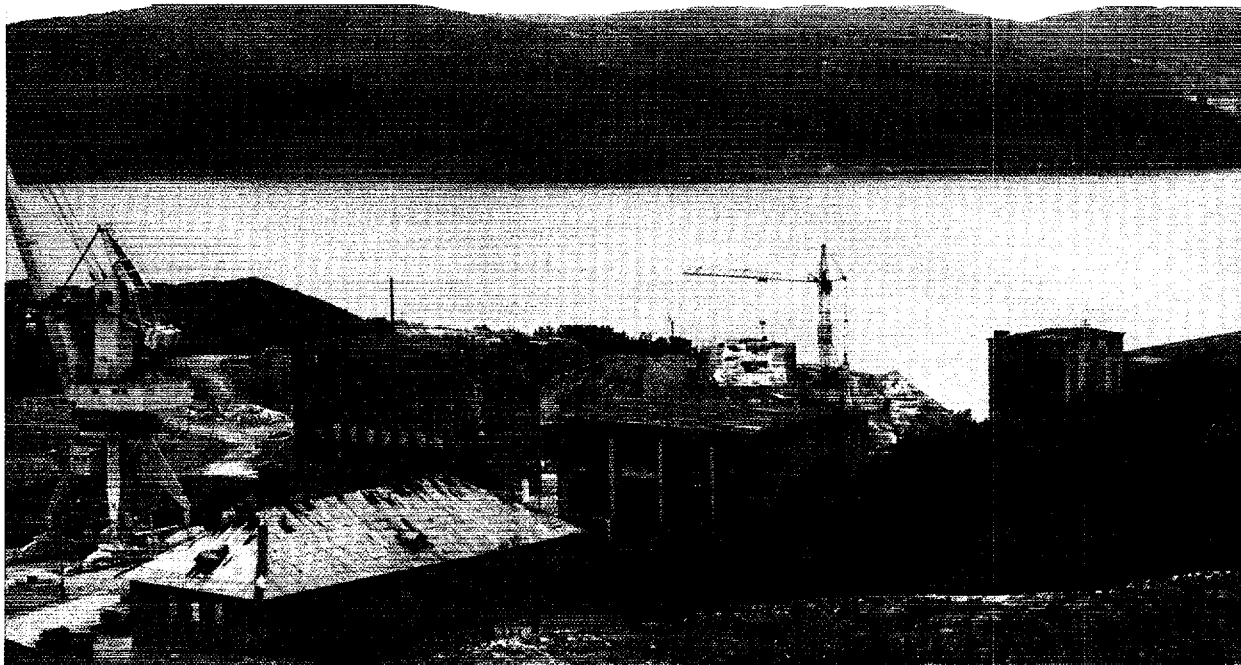

In the early 1960s, a purification plant for liquid radioactive waste was built in the tallest building shown in the photograph. The facility was never taken into operation, and today the building is in such poor condition that it no longer can be utilised. Liquid radioactive waste is stored in five underground tanks beside this building. Rightmost in the picture is Building 5 which formerly housed a storage pool for spent fuel assemblies.

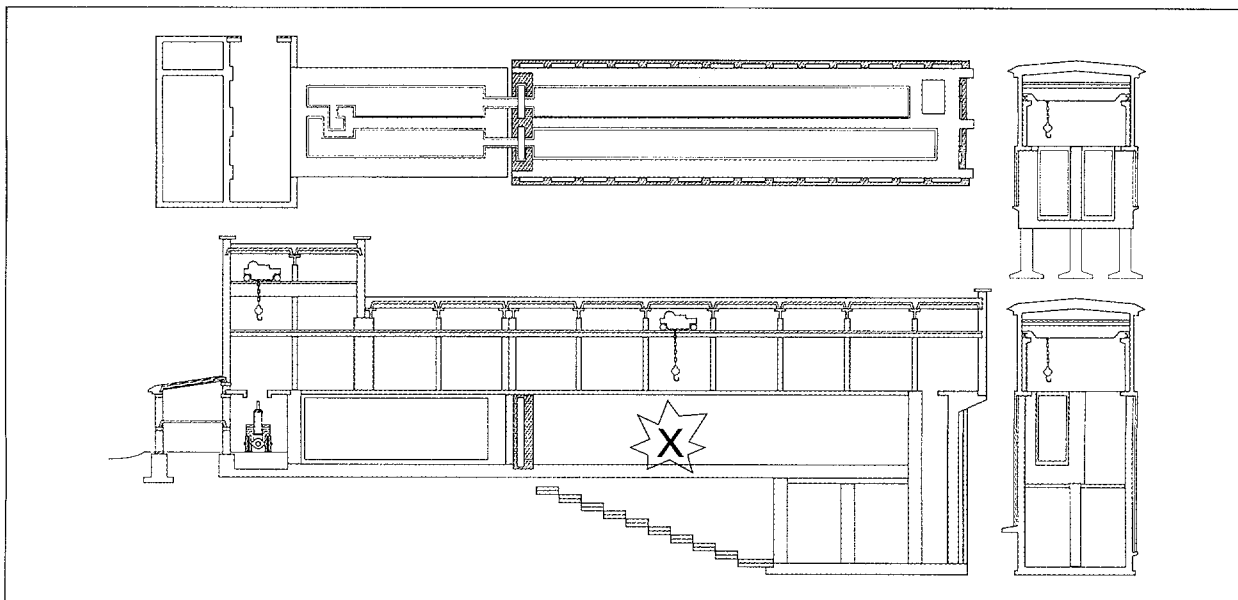

This drawing shows Building 5 from five different angles. Spent nuclear fuel assemblies used to be stored in two storage pools inside the building. The uppermost drawing shows the building as seen from above, while the lower shows the facility as seen from the side. The entrance for lorries carrying spent fuel may be seen to the left. The spent fuel assemblies were hoisted by a crane mounted in the roof to the areas in the storage pool where they were to be stored. The cross marks the area of the storage pool where most of the fuel assemblies fell down in 1982.

ons included building a new installation for loading spent fuel and other solid waste at the quays. (installation no. 104). None of these projects have been commenced. At the same time regulation concerning control and accounting for the waste categories are not adhered to.³⁵³

There are no local residents at Andreeva bay. Each shift is brought by boat from the eastern shore of the Litsa fjord. In 1993 it was found that only 64 % of the stipulated workforce was actually present.³⁵⁴ Andreeva Bay itself is not fenced in. Some of the more important

353 Inspection report from Gosatomnadzor, November 1993.

354 Ibid.

storage facilities are guarded and have partial fencing. Security at the storage repositories has been strongly criticised since two fuel elements were stolen on the night of July 28th, 1993. The fuel elements were subsequently found approximately 600 metres from the storage. Two officers were later sentenced for the theft. An armed guard has now been placed at the storage for fresh nuclear fuel. At this facility there are no barriers between the fuel elements, opening for the theoretical possibility of uncontrolled chain reactions occurring. The storage has no fire alarm.³⁵⁵

A total of 21 000 spent nuclear fuel assemblies and about 12 000 m³ of solid and liquid radioactive waste are stored at Andreeva Bay. This figure also includes contaminated equipment and construction materiel still remaining in Building 5, which was the former location of a storage pool for spent nuclear fuel.

Storage of solid radioactive waste

Solid radioactive waste is stored in its own special area about 200 metres from the sea. The facility covers an area of 80 x 120 metres. About half of the waste is stored in a concrete bunker. The rest is stored in an open area beside this bunker. The waste inside the bunker is packed away in standard containers of 1 m³ each, whereas only a third of the waste in the open area outside has been placed into containers. Equipment of larger dimensions is stored without any particular extra protection. Altogether, just over 6 000 m³ of solid radioactive waste is stored at this particular facility. Most of it is low activity waste, but there is some that is high activity waste, such as control rods and other parts from reactors, and hydraulic components from the primary circuit pumps. The area surrounding this storage area is contaminated.³⁵⁶ At the present time, construction is under way on a new concrete structure which will most probably be used for storing solid radioactive waste. This structure is situated at the edge of the water in the southern part of Andreeva Bay.

Storage of liquid radioactive waste

Liquid radioactive waste is stored in five underground tanks, each of which has a capacity of 400 m³. The total activity of the solid and liquid waste is at least 1 000 Ci. Most of the liquid radioactive waste being stored in these tanks at the present time consists of water from the reactors' primary circuits. Early in the 1960s, a purification plant for liquid radioactive waste was built beside Building 5; however, the facility was never taken into use and the project was shelved in 1964. Today the facility is



Containers of spent fuel assemblies were transported to Building 5 from the quay facility 350 metres below in BeLAZ-450 type lorries like the one pictured. Here the lorry is going through the dosimeter check at the entrance to Building 5. The container may be seen on the flatbed of the lorry.

so run down that it can no longer be repaired. There were some plans to rebuild the plant and install new equipment so that it could be utilised, starting in 1998.³⁵⁷ However, work on the project was never started, and it appears that the plans have been put away. None of the Northern Fleet service ships for liquid radioactive waste and spent nuclear fuel are based at Andreeva Bay; however, they do call in periodically, either to deliver or receive spent fuel and solid and liquid radioactive waste. Since the underground pipelines from the pier facilities to the tanks for liquid waste are no longer in operation, loading and unloading are accomplished manually, utilising tanks that are driven to and fro by lorry.

Storage of spent nuclear fuel³⁵⁸

The first storage facility for spent nuclear fuel at Andreeva Bay, Building 5, was taken into use in 1962. In 1973 the facility was expanded. The storage building was constructed in concrete and consists of two rectangular pools in which the inward walls are lined with steel plate. Each pool is 60 metres long, three metres wide and six metres deep with a total volume of about 1 000 m³. The volume of water in the oldest part of the facility is 600 m³ whereas the area built in 1973 has a capacity of 1 400 m³. The entire building itself is 70 metres long and 18 metres high. The facility was taken into use with the understanding that the spent nuclear fuel was to be stored in the water in the storage pools. The level of water in the pools was to be monitored from the neighbouring building in which the purification facility for

355 *Moscow News*, No. 48, December 8-14, 1995.

356 Meeting on September 21, 1995, with the Environmental Committee of Murmansk which had visited Andreeva Bay in Spring 1995.

357 Yablokov, A. V., *Facts and problems related to radioactive waste disposals in seas adjacent to the territory of the Russian Federation*, Moscow 1993.

358 The information in this paragraph is based on conversations with workers in the Andreeva Bay, and own judgements.

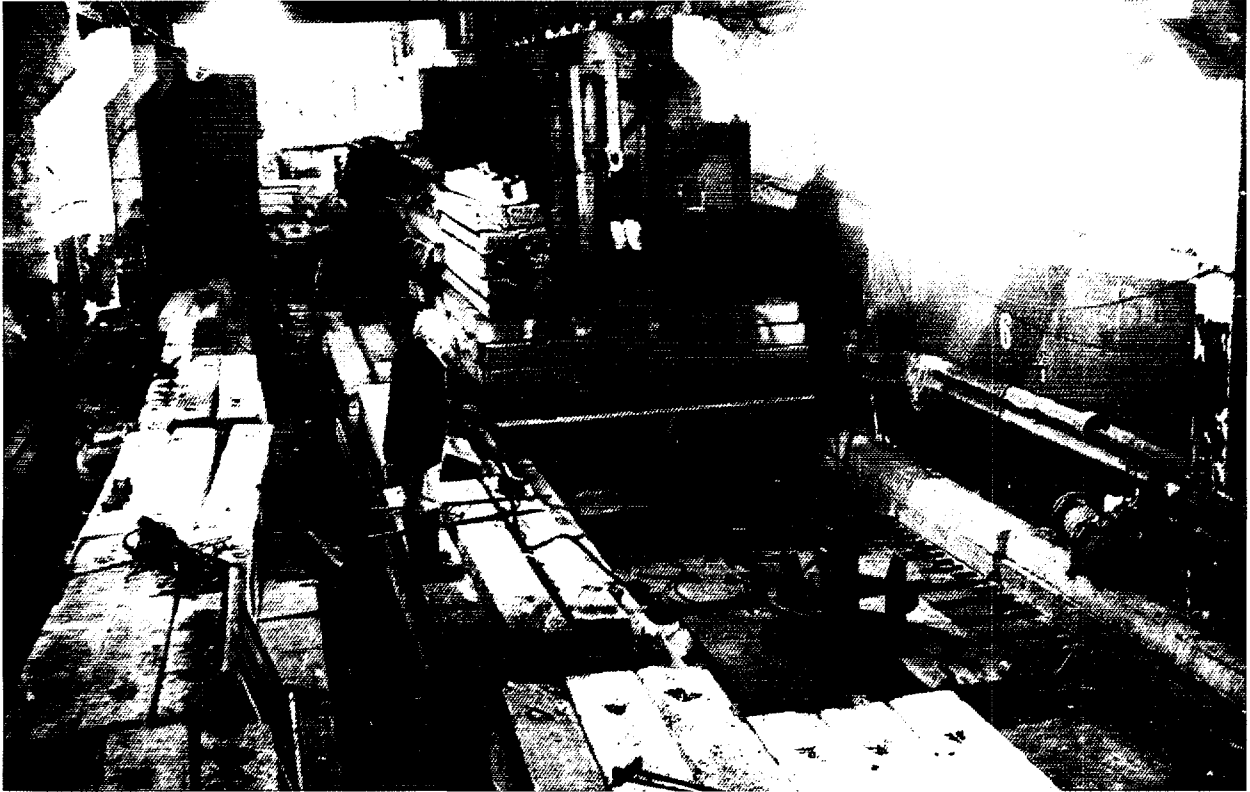

Overview of the inside of Building 5 in the area where there used to be two storage pools for spent fuel assemblies. The photograph was taken during clean-up work following the leaks of the 1980s. Here a fuel assembly is hoisted up from the bottom of the pool. All equipment used during clean-up is radioactively contaminated, and the entire building itself must now be considered as radioactive waste.

liquid radioactive waste was located. Any eventual adjustments would also be made here. However, since the purification facility was not in operation, monitoring of the water level and other measurements had to be done manually. The fuel assemblies were placed alongside each other in rows of five or six and stored in containers. Each container of nuclear fuel weighed up to 350 kilograms. Up until 1973, the facility had a storage capacity corresponding to 550 of these containers. Upon the completion of the second building stage, the capacity had increased by 2 000 for a total of 2 550 containers. These had between 12 750 and 17 850 fuel assemblies, corresponding to 54 to 76 reactor cores. Later, as the Northern Fleet faced storage capacity problems for its spent fuel, the possibility of placing the containers closer together in the pools was considered. This idea was rejected for reasons of radiation safety.

Spent nuclear fuel assemblies from all of the Northern Fleet shipyards were sent to Building 5. The containers were transported aboard Northern Fleet service ships of type 326 M and type 2020 to a special pier in Andreeva Bay. Here the derricks of the service ships lifted the holding containers up from the storage compartments and transferred them into a larger transport container. The transport container was then hoisted over to

a dumper of the type BeLAZ-450 and driven up the 350 m long road up the hill and into Building 5. Unloading from the dumper took place inside Building 5 using a crane with a lifting capacity of 15 tonnes. The containers full of spent fuel were then removed from the transport container into an unloading room and transferred into a pool of water. Here it was attached to a chain hook beneath a special crane on rollers mounted in the roof of the building. This crane was driven to the designated location inside the building where the containers holding the fuel assemblies were to hang.

The containers of spent nuclear fuel were suspended so that they were covered by four metres of water. This was to protect the facility's employees from receiving dangerously high doses of radiation, as well as to cool the heat producing fuel assemblies. One of the earliest problems at the storage facility was that water penetrated the containers, resulting in direct contact between fuel and water.

In February 1982, the personnel of Building 5 discovered that the level of water in the second pool had dropped and a dangerous leak had developed (see the section below). It soon became apparent that the storage facility could no longer be used, and measures were taken to remove the fuel assemblies from the building.

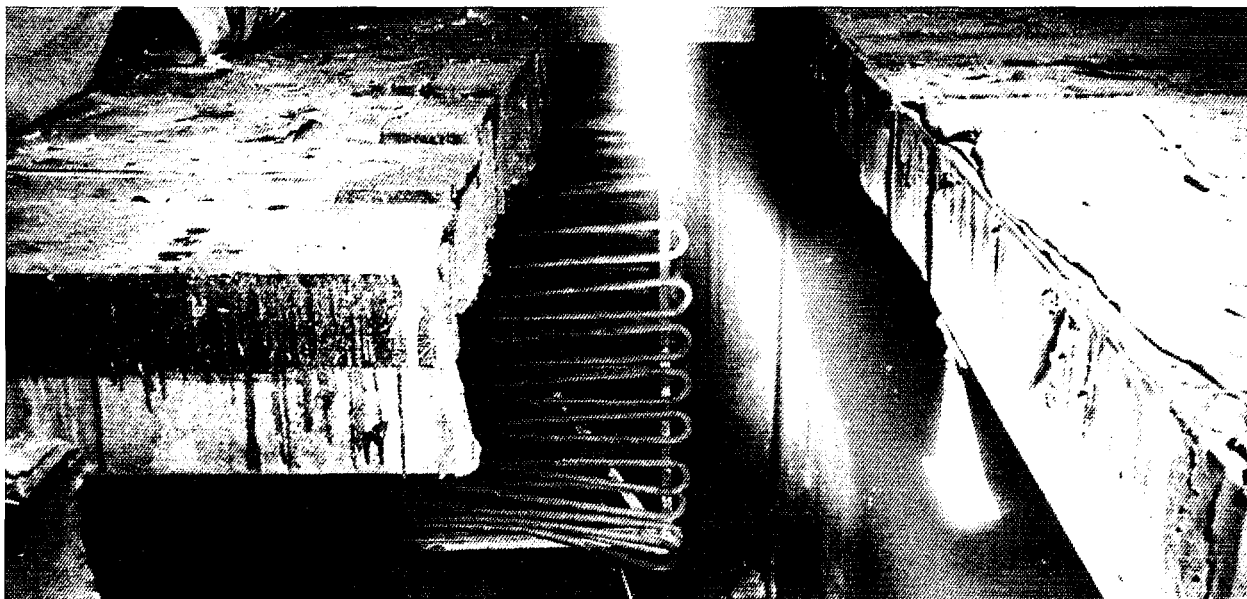

In this picture parts of the damaged lid over the storage pool in Building 5 are shown. The pipes beneath the cover were a part of the pool's cooling system. The cooling system was necessary for controlling the build-up of heat in the water around the fuel assemblies.

The picture shows damaged fuel assemblies at the bottom of the storage pool in Building 5. The containers, which hung from chains, fell down and parts of the fuel rods were damaged against the pool floor. The floor of the storage pool has been partially covered by concrete in the time since this picture was taken. Intense radiation (400 mGy/h / 40 R/h) is still being measured in this area of Building 5 owing to radioactive contamination of the pool floor, and these parts of the storage pool must be treated as high level waste.

The accident at the storage facility for spent nuclear fuel³⁵⁹

In February 1982, it was discovered that the water level of the pools in Building 5 had fallen dramatically. Upon closer inspection it was learned that there was a serious leak of highly radioactive water from the pools. The first open information about the accident came to light in March 1993 through the environmental foundation Bellona.³⁶⁰ The first official Russian confirmation of a leak of radioactivity in Andreeva Bay did not come until later in the same year when Russia's environmental advisor, Aleksey Yablokov, issued an official report on the practice of dumping radioactive waste at sea.³⁶¹ A detailed description of the incident follows below:

The location of the leak in the second pool was in the lower parts of a concrete wall which had been covered on the inside with steel plate. These steel plates had cracked, and ice had formed on the outside of the building as the water continued to leak out. A commission of specialists from the Northern Fleet was formed to investigate the accident. Their calculations showed that

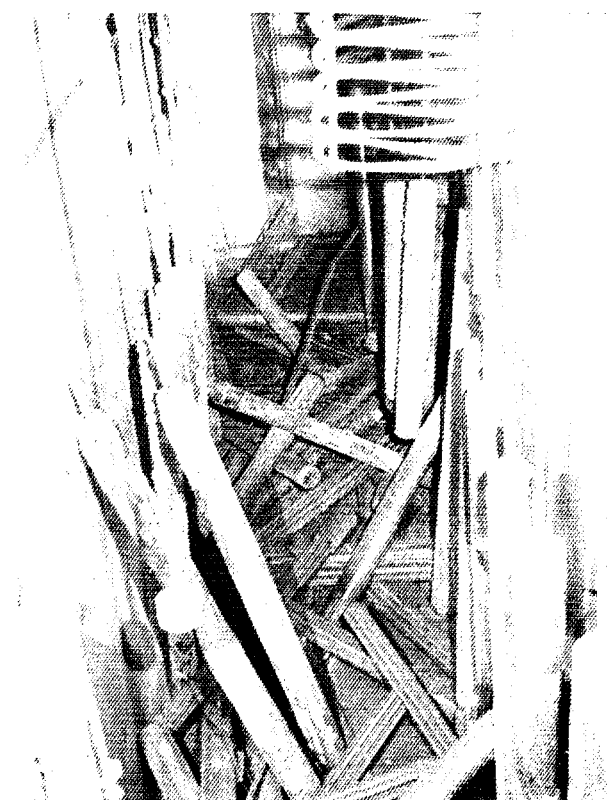

the pool was leaking at a rate of about 30 litres a day. The commission worked with the builders of Building 5 to develop a plan of action. In the meantime, the leak grew worse. By April 1982, it was calculated that water was leaking from the pool at a rate of 100 litres a day. Measuring equipment mounted on the outside of the wall in the vicinity of the leak indicated radiation levels of 15 mGy/h (1.5 R/h). The level of radioactivity at the bottom of the pool was about 150 MBq/l (4×10^{-3} Ci/l). The radioactivity of the water which had leaked out was

359 Unless otherwise stated, the information in this paragraph is based on conversation with workers who participated in the cleanup work after the leak.

360 The Norwegian newspaper *Aftenposten*, March 13, 1993.

361 Yablokov, A. V., *Facts and problems related to radioactive waste disposals in seas adjacent to the territory of the Russian Federation*, Moscow 1993.

measured at 110 MBq/l (3×10^{-3} Ci/l). In August 1982, work was started on covering the lower parts of the walls and floor of the pool with concrete. About 600 m³ of concrete was poured. Simultaneously, an attempt was made to filter the water that was leaking on the outside of the building with the aim of preventing the flow of contaminated water into the sea and the subsequent contamination of the area. The distance from Building 5 to the sea is 350 m, and the attempt to filter the water proved to be ineffectual, as were the efforts to stop the leaks. Towards the end of September 1982, the leak had increased and was now calculated to be up to 30 tonnes of water a day. The water in the pool had sunk to such a low level that there was a risk that the containers of fuel assemblies would no longer be covered. This would result in large doses of radiation to the employees, radioactive contamination of the other storage pool in the building as well as the brook flowing into the Litsa Fjord. The ineffectiveness of the action taken by the experts from Minatom resulted in the Northern Fleet assuming responsibility for stopping the leak and averting a larger catastrophe in the local area. Considerable resources were directed to the effort, and a decision was made to place a lid of iron, lead and concrete over the pool to shield against gamma radiation. On October 5, 1982, Admiral A. Mikhaylovsky, Commander of the Northern Fleet, approved a plan for managing the accident and further cleanup in which the following measures were also taken:

- Completion of the work to cover the site of the leak in the concrete;
- Putting in a purifying plant to reduce radioactivity in both pools;
- Preparing the nuclear fuel in pool no. 2 for removal;
- Building a pipeline to add water to the pools which could also be used to empty them;
- Intensifying the work to complete concrete tank 3A in order to be able to receive spent fuel from Building 5;
- Decontamination of the area around Building 5.

A new project staff was appointed to achieve these points, headed by A. Petrovsky, technical director of the Navy. It was he who had suggested using concrete tanks 3A, 2A, and 2B to store spent nuclear fuel assemblies.

While work was underway to cover the first pool, in November 1982 it was discovered that the water level in the second storage pool was also sinking. In the course of one week, water was leaking out of the pool at an average rate of 10 tonnes a day. The activity of the water was 11 MBq/l (3×10^{-4} Ci/l). By December 1982, the lid over the first pool had been completed, and the rate of the leak had been reduced so that the level of water could be maintained at about three metres. The activity of the water in this first pool was 1,9 MBq/l (5×10^{-5} Ci/l). The second pool was leaking at a rate of about three tonnes a day, and here the activity was still 11 MBq/l (3×10^{-4} Ci/l). Since fresh supplies of water were continually

pumped in, the water level stayed at about four metres.

On February 14, 1983, a special commission from the Ministry of Defence visited Andreeva Bay. The commission approved both the measures that had been taken to stop the leak and the modification plans to turn the three concrete containers into storage tanks for spent nuclear fuel. Simultaneously it was decided that Building 5 would no longer be used to store spent nuclear fuel assemblies. In June 1983, work was started to remove the containers holding fuel assemblies from the second storage pool. At this time, the activity was highest in this storage pool. Most of the containers were transferred to concrete tank 3A, while a few more were transported to Mayak. By January 1984, all 1 000 containers had been removed. A complicating factor was that a considerable number of the fuel assemblies had fallen out of their containers and had to be raised from the bottom of the pool. About 70 containers could not be raised in the normal way; subsequently special cranes were constructed for them. A decision was made to wait two years to allow the levels of radiation to drop before removing the containers from the first storage pool.

Once the first storage pool had been covered with a lid and the second pool had been emptied, the employees who had carried out the work were rewarded with an additional vacation period and engraved watches. The project leader received a bonus of 240 roubles, equivalent to one half of his monthly salary.

In 1989, work was started to remove the fuel elements from the first storage pool and the remaining containers that had been left in the second pool. Both pools were emptied, and a total of 1 400 containers of fuel assemblies were taken out. A special group of experts was formed to remove the fuel assemblies that had fallen to the bottom of the pool. These specialists were drawn from a number of institutions that reported directly to Minatom, including NITI (Sosnovy Bor), VNIPIET (St. Petersburg), FEI (Obninsk) and individuals from the Navy's training centre in Sosnovy Bor. The group of 12 to 14 people was led by V. Bulygin in the task of raising approximately 120 damaged fuel assemblies from the bottom of the pool and transporting them away. The most dangerous part of the work lay in placing the damaged fuel assemblies into new containers, and it has been reported that seven or eight members of the group received radiation doses of 90 to 100 mSv (9 to 10 rem). The highest permissible annual dose is 50 mSv (5 rem).

The containers were raised and taken to another storage area, most probably the storage facility for solid radioactive waste at Andreeva Bay. Upon the completion of the work, the members of the team were recognised and various honours of the Soviet Union were bestowed upon them. Some were even granted the privilege of a car. The leader of the group, V. Bulygin, was awarded the medal "Hero of the Soviet Union". The total

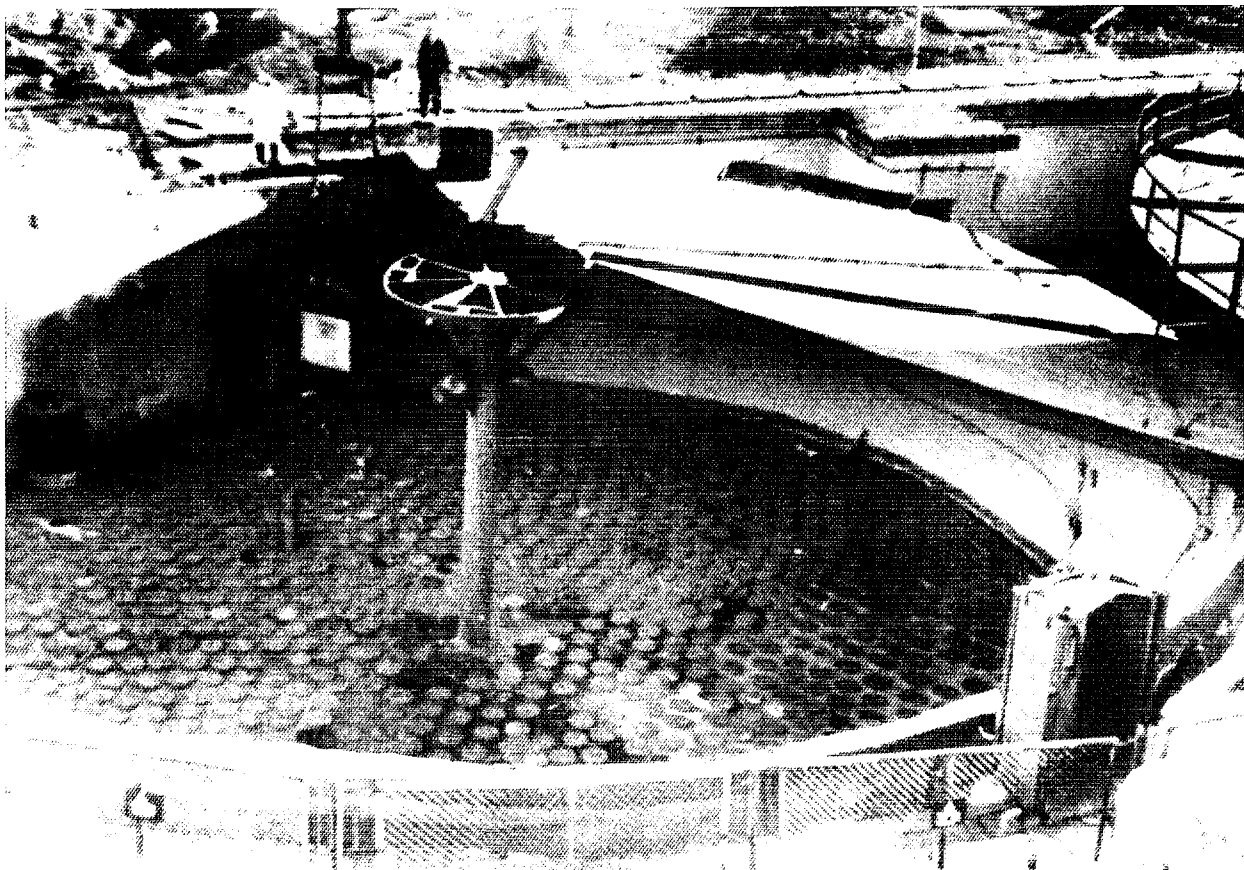

A container of spent fuel assemblies is transferred to storage tank 2A. A total of 1.200 containers are stored in this tank. The use of these tanks to store spent fuel assemblies was intended to be highly provisional and temporary. Today the tanks are in very poor condition.

The picture to the right show a crane used for lifting the fuel assemblies.

cost of the work to empty Building 5 was about 5 million roubles (1989 figures).

It has been estimated that a total of about 3 000 m³ of water with an activity of 110 TBq (3 000 Ci) leaked from the storage pools. Measurements made in 1995 showed that the brook running from Building 5 was contaminated,³⁶² A total area of 1 300 m² is radioactive contaminated. In the Sea outside the Andreeva Bay there have also been measured contamination.³⁶³ It seems likely that much of the radioactive water from the leakage was absorbed into the ground outside the building. No samples have been taken from this area.

As of today, Building 5 is not in use, and it is in very poor condition. Nothing has been done to deactivate the building, and a great deal of equipment remains there. Levels of gamma radiation as high as 400 mGy/h (40 R/h) have been detected in certain areas at the bottom of the storage pools, probably due to spills of irradiated uranium from the fallen fuel assemblies. One suggestion

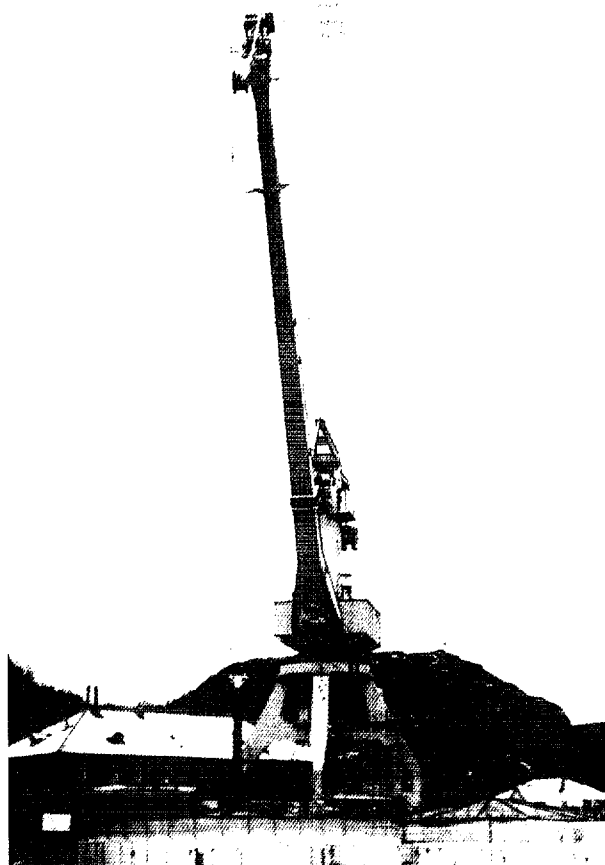

362 Meeting on September 21, 1995 with the Environmental Committee of Murmansk which had visited Andreeva Bay in Spring 1995.
363 Petrov, O. *Radioactive waste and spent nuclear fuel in the navy of Russia*, 1995 and *Polyarnaya Pravda* September 20, 1995.

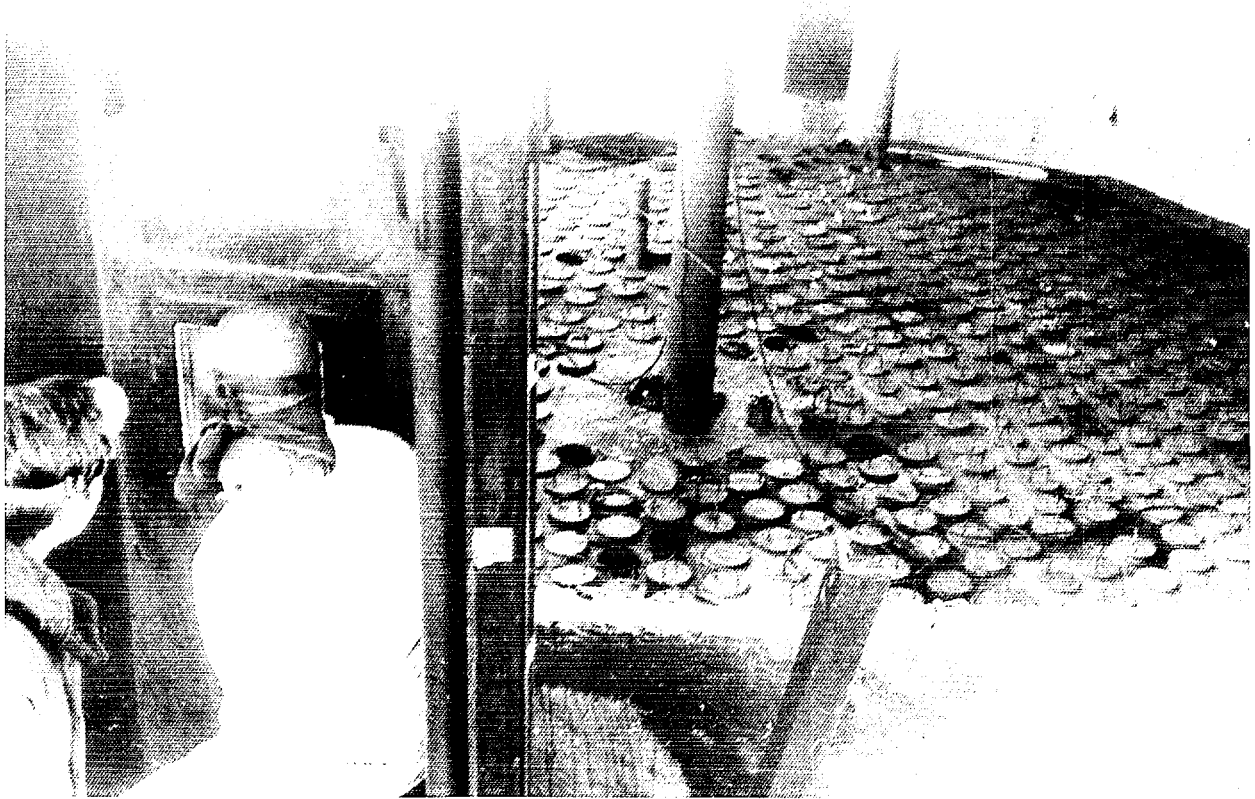

The workers operating the cranes for lifting the fuel assemblies in and out of the storage tank are shielded behind a wall of concrete and iron. An air cooling system prevents the build-up of heat in the storage tanks. The space between the storage cells containing the fuel assemblies is filled with concrete.

is to cover the bottom of the pool with concrete, but this has not been done.

Parts of the actual construction of the storage pools as well as some of the equipment inside the building are considered to be high and medium level waste. There have been other proposals to use Building 5 as a storage area for other kinds of solid radioactive waste since the existing storage facility at Andreeva Bay is filled beyond capacity; however, because the building is in such poor condition, this has not been done either. There are no clear plans for what to do with Building 5 in the future.

Storage tanks for spent nuclear fuel

Following the recommendation of specialists in the Northern Fleet's technical department, a proposal was developed to modify three large underground concrete tanks to serve as future storage for spent nuclear fuel. The three tanks had originally been designed to store liquid radioactive waste, but had never been used for such. Each of the tanks had a capacity of 1000 m³ and were located immediately below Building 5. The proposal was approved by the Northern Fleet Command, and modification costs in 1982 figures totalled 400 000 roubles. During the modification process, pipes measuring 25 to 27 cm in diameter were installed in the tanks and the spaces in between the pipes were filled with cement.

A container holding seven fuel assemblies could then be lowered into each pipe. This method of storing spent nuclear fuel is known as dry storage in that water is not used as a cooling agent and shield against radiation. A central ventilation system was built for cooling purposes instead. Modification of the first concrete tank (3A) began in November 1982, with the work being carried out by military personnel. Seven months later, in June, 1983, the concrete tank was taken into use. The second and third tanks (2A and 2B respectively), were taken into use in 1985 and 1986. The first tank holds 900 containers of fuel assemblies, while there are 1 200 containers in each of the two newer tanks. This corresponds to about 21 000 fuel assemblies, or about 90 reactor cores. As of today, all three tanks are completely full.

A portable crane (KPM-40) with a 30 m boom and a lifting capacity of 40 tonnes has been built to lift the containers of spent nuclear fuel in and out of the tanks. A decontamination unit and a dosimeter monitoring station were also built at this time.

Undamaged fuel assemblies were transferred to the three concrete tanks from Building 5. Starting in 1984, fuel assemblies from routine submarine refuelling operations were also stored here. It was originally intended that the concrete tanks would serve as short term, temporary storage until a proper facility could be built. Fuel assemblies were to be stored in these tanks no more than

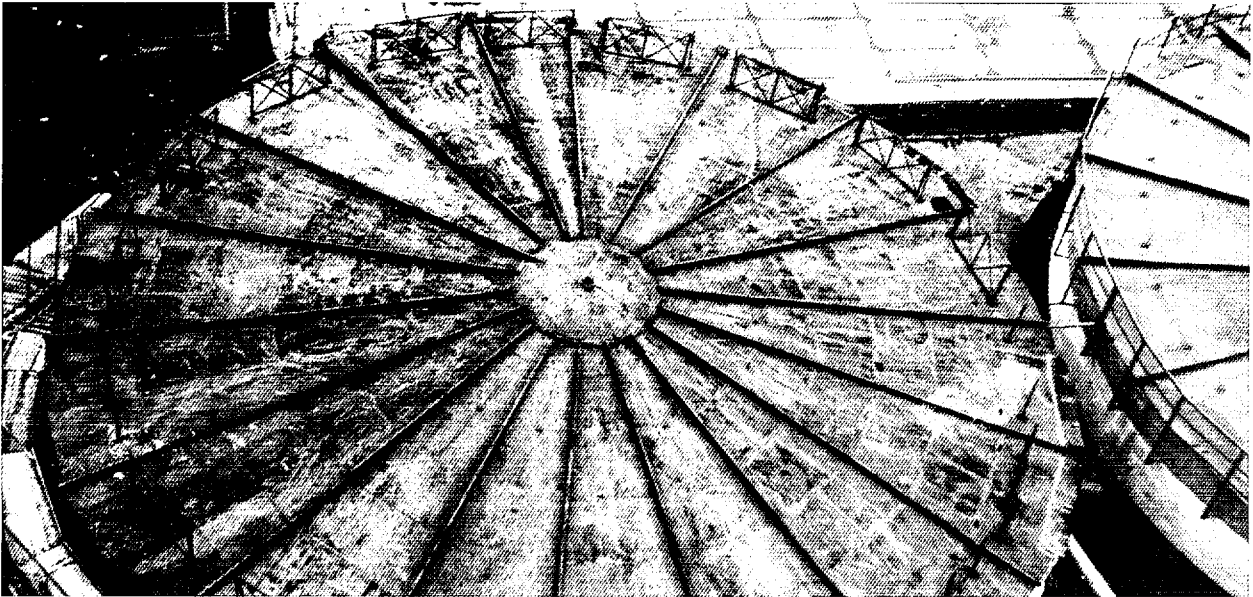

The storage tanks 2A and 2B. These tanks were taken into use in 1985 for the temporary storage of spent nuclear fuel assemblies. Each tank stores 1.200 containers of spent fuel assemblies, and in a third tank another 900 containers are stored. These storage tanks were originally built to store liquid radioactive waste, and using them to store spent fuel assemblies was intended only as a temporary solution until a new storage facility could be built at Andreeva Bay. The lids over the tanks are in very poor condition. A large crack can be seen in the enlarged photograph. The tanks are located about 300 meters from the sea.

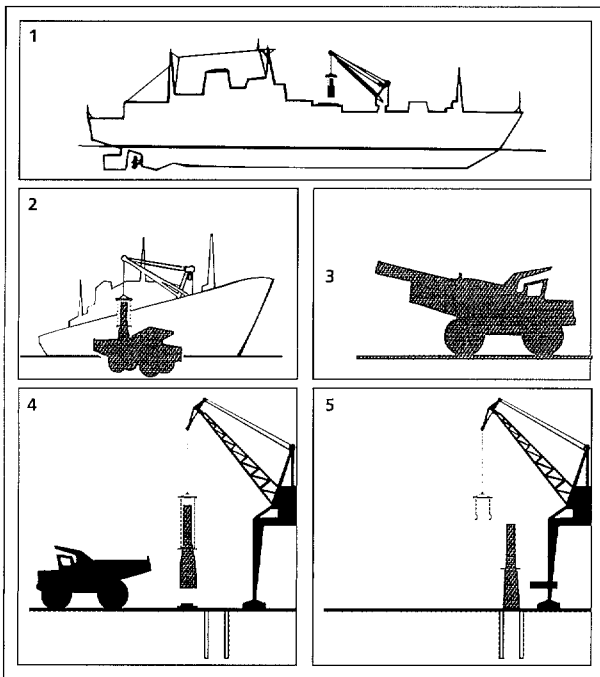

These drawings show how spent fuel assemblies are transported to the storage tanks in Andreeva Bay. The containers are shipped on board Project 2020 - Malina class service ships from the Northern Fleet's naval bases or shipyards to Andreeva Bay (1). The service ship's own cranes are used to transfer the containers to a BeLAZ-450 type lorry at the pier (2). The lorry then drives 300 metres up the road to the storage tanks (3), where a KPM-40 type crane is used to lift the containers off the truck. These are then placed on a concrete platform alongside the storage tanks (4). Later the containers are hoisted over to the storage tank and the spent fuel assemblies lowered down into the storage cells (5).

three or four years. Subsequently, the shielding around the tanks against corrosion and external radiation had a designed lifetime of four years. Plans for a new storage facility at Andreeva Bay have existed since 1984, but at present, are only on paper. This is probably due to a lack of financing for the project.³⁶⁴ Responsibility for the building of the new storage facility rests with construction firms reporting directly to Minatom.

Outdoor storage of spent nuclear fuel

In addition to the three concrete tanks, there is also an open area at Andreeva Bay where 52 containers of spent fuel assemblies are stored. These containers hold fuel from the very first refuelling operations carried out on Soviet nuclear submarines and were placed at their present location in 1962. In 1991, about 20 of the containers were emptied, and the spent fuel assemblies were transported to Mayak. A remaining 32 containers holding between 200 and 220 fuel assemblies are still being stored at Andreeva Bay out in the open. No decision has yet been made as to what to do with them. Accurate data on the contents is lacking. Since the containers have been exposed to the elements for almost 35 years, they are strongly corroded. The lids of some of them have cracked allowing water to enter and come into direct contact with the fuel elements. This has probably caused damage to the elements and they can not be taken for reprocessing in the usual way. The area where this fuel is stored is radioactively contaminated. At the reloading point for spent fuel elements beside the

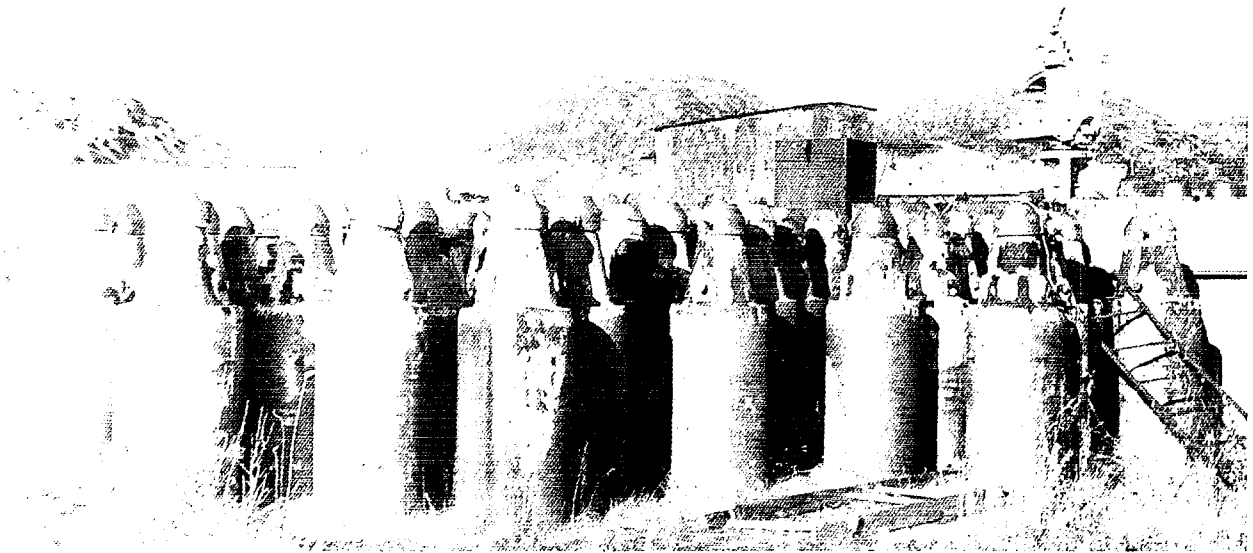

There are 32 containers with a total of 200-220 spent fuel assemblies being stored in an open, unshielded area at Andreeva Bay. These containers have been stored in this manner since 1961-62, and the containers are in very bad condition. The whole area surrounding these containers is radioactively contaminated.



A close-up photograph of the containers that are being stored outside shows large cracks in several of the container lids. During the six months of winter, these containers are covered by ice and snow. Most of the fuel assemblies inside the containers are probably damaged and cannot be transported away from the area using standard equipment.

concrete tanks 2A and 2B, there are six transport containers type TK-11 (type 6), with spent fuel elements. These have not been unloaded because there is no spare storage capacity for them.³⁶⁵

Uranium stored at Andreeva Bay

Far more technical information about each particular fuel assembly would be required in order to estimate the total amount of ^{235}U in the spent nuclear fuel assemblies that are stored at Andreeva Bay. Nonetheless, it is possible to give some estimates on the basis of the available information. Fuel assemblies equivalent to about 90 reactor cores are stored in the three storage tanks. It has been stated that there is about 50 kg of ^{235}U in each reactor core of first generation Russian submarines, while the reactor core of a second generation submarine holds about 70 kg of ^{235}U . There is about 115 kg of ^{235}U in the reactors of the third generation submarines. The total uranium content of a 2nd or 3rd generation reactor is between 300–350 kg.³⁶⁶

It is reasonable to assume that most of the fuel assemblies now stored at Andreeva Bay are from second and third generation submarines, since most of the first generation nuclear submarines were decommissioned towards the end of the 1980s. These vessels were laid up with the nuclear fuel remaining in the reactors. Owing to a lack of capacity at the intermediate storage facilities on the Kola Peninsula, the Northern Fleet has prioritised refuelling the operational submarines at the cost of defuelling those that have been taken out of service.

³⁶⁵ Inspection report from Gosatomnadzor, November 1993.

³⁶⁶ Bukharin, O. and Handler, J., 1995.

4.4

Vidyaevo

The naval base Vidyaevo consists of two bases: Ara Bay and Ura Bay. The town of Vidyaevo itself with its 20 000 inhabitants lies on the eastern side of the Ura Bay, six kilometres north of the actual village of Ura Bay. The area has served as a base for diesel powered submarines since the beginning of the 1960s, and in 1979 it became a base for nuclear submarines too.³⁶⁷

In the 1980s, Ara Bay was a relatively large navy base serving nuclear submarines of all three generations; however, in recent years, the base has decreased in importance. There are 14 nuclear submarines laid up at the base at this time, nine of the Project 675 - Echo II class, and five of the Project 670 - Charlie-II class. These submarines between them account for 23 naval reactors, all of which still contain their fuel.³⁶⁸ The remaining active submarines that are based here are of the Project 971 - Akula class.³⁶⁹ The base at Ara Bay is one of the most poorly equipped bases of the Northern Fleet.

The nuclear submarine K-192 (formerly K-131) which suffered a reactor accident in June 1989, was laid up at Ara Bay until 1994. Since it was in danger of sinking there at the pier, it was moved to Shipyard No. 10 Shkval at Polyamy.³⁷⁰ However, 74 TBq (2 000 Ci) was released to the sea in connection with the accident, and an area of 1 km² in Ara Bay was contaminated by radioactivity.³⁷¹

Three tunnels originally intended to conceal nuclear submarines, have been blasted out at the naval base in Ara Bay. These tunnels are 30 meters in diameter, and each one measures 400 meters in length.³⁷² None of them has been completed. For many years there have been plans to use these tunnels to store reactor compartments from dismantled submarines. The use of the tunnels was intended as a temporary measure until a permanent repository for radioactive waste could be established in north-western Russia. A storage period of about 80-100 years for up to 100 reactor compartments is considered a realistic possibility; however, at the present time, there are no available funds to finance this project.³⁷³ (For further information, see Chapter 6 which discusses the decommissioning of nuclear submarines).

A *Nurka* type reactor is also stored at Ara Bay still containing its nuclear fuel. This type of reactor was

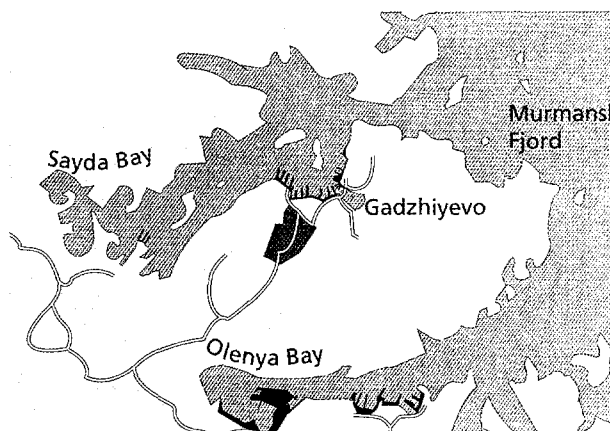

Map 4. Vidyayev Naval Base and Sayda Bay.

intended to be installed in a diesel-powered submarine. It is not known whether or not the reactor was ever actually used.³⁷⁴

It is believed that there is also a smaller storage area at Ara Bay for solid and liquid radioactive waste. In addition there is a storage tank of 3 m³ in volume that is used to collect liquid radioactive waste from submarines.

The base at Ura Bay is used for diesel submarines and a few smaller surface vessels.³⁷⁵

4.5

Sayda Bay

Sayda Bay is a former fishing village that was annexed as a military area in 1990. Its former inhabitants were moved out, and the area is now used for storing hulls and reactor compartments from nuclear submarines. In April 1995, twelve submarine hulls were tied to three different piers in Sayda Bay. The water is 20 m deep at the piers. The oldest pier is over 30 years old and was built for the local fishermen. According to base authorities, this pier could sink at any time.³⁷⁶ Many more piers have been planned for Sayda Bay, but the project has been halted owing to a lack of funds. According to Northern Fleet specialists, the reactor compartments can be stored at the piers for a period of up to ten years. After that they should be placed into dry docks and transported to a storage facility where they will not come into contact with water. Otherwise they should be dismantled.

367 Mormul, N. Note, 1995.

368 *Decommissioning of obsolete nuclear submarines and storage of reactor compartments*. Document presented at conference on *Problems in the removal of nuclear submarines and their dismantlement*, Moscow, June 19-22, 1995.

369 International Institute for Strategic Studies, 1995.

370 Bellona Magasin, No. 4 - 1995.

371 Petrov, O., *Radioactive waste and spent nuclear fuel in the Navy of Russia*, 1995.

372 Perovsky, V. A., VNIPIET, *Possibilities for landbased storage of reactor compartments*, 1995.

373 Conversations with Pantelev, Chief of the Northern Fleet Technical Department, January 1995.

374 Information given by representatives for the Ukrainian Department of Defence, 1995.

375 International Institute for Strategic Studies, 1995.

376 Conversations with the controllers of the reactor storage facility in Sayda Bay, 1995.



This small fishing village at Sayda Bay has been annexed, and submarine hulls and reactor compartments are stored at three piers. Reactor compartments that have been cut out from decommissioned submarines at the naval yards in Severodvinsk and Nerpa are towed here to Sayda Bay. Today there are 12 reactor compartments tied to the piers here, but this figure is expected to increase in conjunction with the ongoing decommissioning of numerous other nuclear submarines.

At the present time, there are 12 reactor compartments at the three piers. Four of them are from the submarines K-216, factory no. 424 (Yankee class) with eight compartments; K-415, factory no. 451 (Yankee) with three compartments; K-241, factory no. 462 with three compartments, and K-463, factory no. 915 (Alfa) with pontoons welded on both front and back. Four of the twelve compartments were towed to Sayda Bay between the summer and autumn of 1994.³⁷⁷

The reactor from the submarine K-463 was towed to Sayda Bay from Severodvinsk at the end of the 1980s. There are 20 tons of solid radioactive waste stored in the reactor compartment which was filled in Severodvinsk. The reactor compartment was washed prior to being towed to Sayda Bay in 1994. Indeed, all of the reactor compartments presently stored at Sayda Bay have originated in Severodvinsk, as will those that come here in the future.

In the fall of 1995, three new reactor compartments were scheduled to be towed to Sayda Bay. The two first reactor compartments were to be towed from Severodvinsk and came from the submarines K-228 and K-444 (both Yankee class). Both of them have a three-compartment reactor unit. The third reactor compartment from the Victor-I class submarine K-481, was scheduled to be towed from Nerpa Shipyard.³⁷⁸ There are two pon-

toons mounted on this reactor compartment to keep it afloat. One additional reactor compartment from Nerpa Naval Yard is expected at Sayda Bay during 1996. This reactor comes from the submarine K-479 (Charlie).³⁷⁹ A submarine hull from Gadzhievo is also due to be transported here.

The nuclear fuel has been removed from all of the reactor compartments that are laid up at Sayda Bay; however, over the course of 1996, the reactor section of a Project 705 - Alfa class submarine is due to be towed to Sayda Bay.³⁸⁰ In this case, the fuel will remain on board the submarine.

Monitoring of the submarine hulls and the reactor compartments ability to float is carried out by Navy personnel residing at Sayda Bay. In the event that a hull or reactor section sinks, it is their responsibility to report this to the Northern Fleet rescue service. The rescue service then sends a tug and attempts to pull the reactor compartment/hull up onto land. Monitoring the levels of radiation at the piers is undertaken by the Radiation Safety Service from Gadzhievo Naval Base. The maximum permissible level of radiation on the outside of the reactor compartment is set at 200 mR/h. There are no reports of radiation at higher levels than this being measured outside the reactor compartments.

377 Arkhangelsk Ecological Committee, supervising authority to the Navy, 1994.

378 Decree No. 514 of the Russian Government, July 24, 1992.

379 Preface in the document: *Problems with decommissioning nuclear Submarines, and protection of the environment in the Arctic regions*, Severodvinsk, March 15-16, 1995.

380 Ibid.

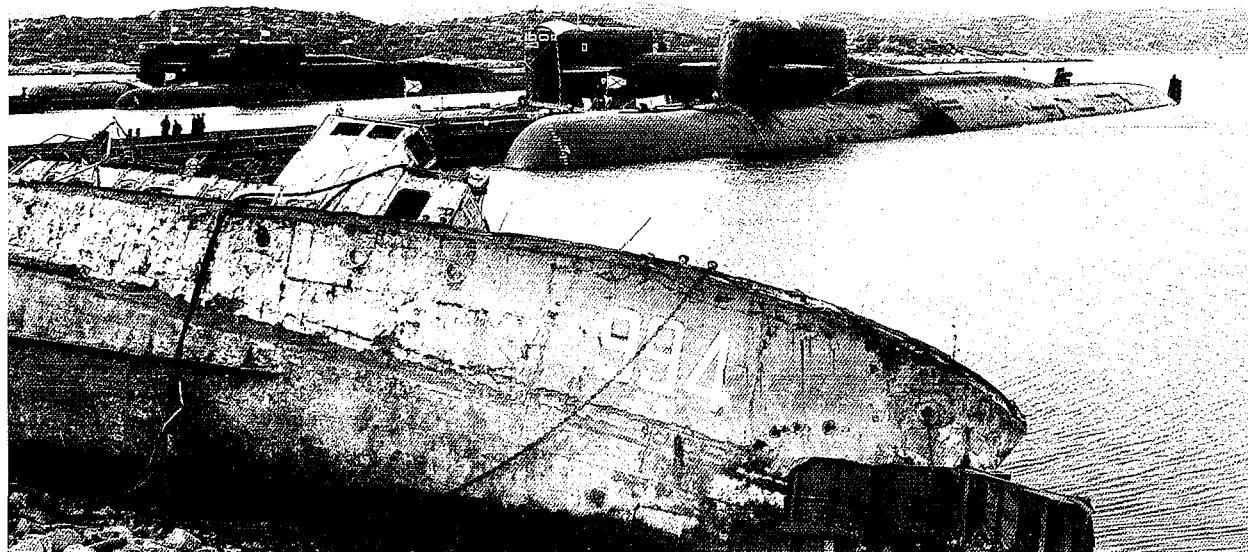

This naval facility in Gadzhievo serves as a base for Delta and Akula class submarines. This navy base is one of the largest in the Northern Fleet. The submarines pictured here are Delta-I and Delta-IV class vessels.

4.6

Gadzhievo

The naval installation at Gadzhievo consists of two bases. One is located in Sayda Bay at the town of Gadzhievo; the other one is situated at Olenya Bay. The facility at Gadzhievo (also known as Skalisty) was taken into use in 1956 as a base for diesel-powered submarines. Nuclear submarines have been stationed here since 1963³⁸¹, and at present, submarines of Project 667 BDRM - Delta-IV class, Project 667 BDR - Delta-III class and possibly a few submarines of Project 971 - Akula class are based here.³⁸² Recently a new facility for removing spent nuclear fuel was built at the base, and there are six laid up submarines here.³⁸³ Gadzhievo has its own radiation safety service with floating containers for liquid radioactive waste at its disposal. In addition, 200 m³ of liquid radioactive waste and 2 037 m³ of solid radioactive waste are stored in other facilities.³⁸⁴

Gadzhievo has a facility for removing spent nuclear fuel from submarines. The service ships PM-12, PM-50, PM-78 and PM-128 are often based here in connection with this work.³⁸⁵

The second naval base facility is located west of Polyarny in Olenya Bay. There are nine submarines based here, two of Project 667 BD - Delta-II class, and seven of Project 667 BDRM - Delta IV class. Four of the Northern Fleet

mini-submarines from Project 1851 - X-ray class and Project 1910 - Uniform class are also based at Olenya Bay.³⁸⁶

4.7

Severomorsk

Severomorsk serves as the main base and administration centre for the Northern Fleet. The city lies 25 km north of Murmansk on the eastern side of the Murmansk Fjord, and has a population of 70 000. The Northern Fleet's large surface vessels are based here, of which two are nuclear-powered Project 1144 - Kirov class battle cruisers: *Admiral Ushakov* and *Admiral Nakhimov*.³⁸⁷ The newest nuclear-powered battle cruiser *Pyotr Veliky* is scheduled to be delivered from the shipyard in St. Petersburg over the course of 1996. Severomorsk has no permanently stationed nuclear submarines.

The ship repair factory SRZ-82 is located in Safonovo, a rural town also in the Severomorsk area. This factory has a number of floating docks used in the repair of nuclear submarines and surface vessels. The area's largest floating dock is located here, and the factory undertakes the repair of the largest Northern Fleet submarines, including the Project 941 - Typhoon class.

Shtyukozero, another rural town located about 8 kilo-

381 Mormul, N. Note, 1995.

382 *Jane's Intelligence Review*, December 1993, and *Jane's Defence Weekly*, November 1995.

383 *Decommissioning obsolete submarines and storing reactor compartments*. Paper presented at conference on *Problems in decommissioning and dismantling of nuclear submarines*, Moscow, June 19-22, 1995.

384 Information from Murmansk County Committee on Ecology and Natural Resources, Radiation Security Department, 1993.

385 *Problems with decommissioning nuclear Submarines, and protection of the environment in the Arctic regions*, Severodvinsk, March 15-16, 1995.

386 *Jane's Fighting Ships 1995-96*, 98th edition.

387 *Morskoy sbornik*, no. 7 - 1995 and *Jane's Fighting Ships 1995-96*, 98th edition.

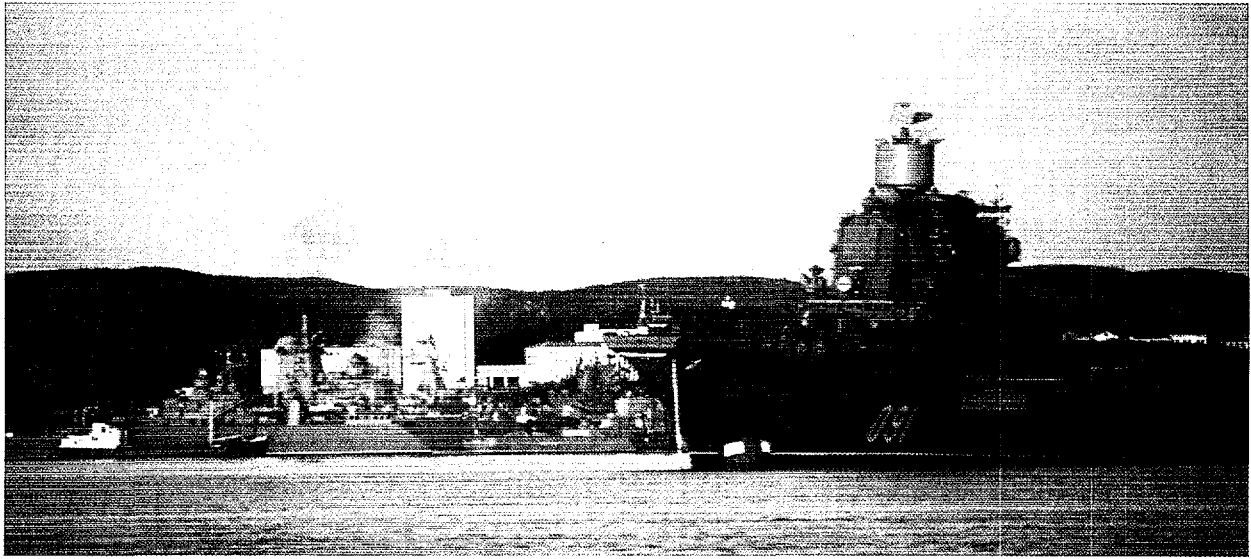

Severomorsk is situated at the Murmansk Fjord and is the Northern Fleet's main base. This closed city has about 70.000 inhabitants and is located about 20 kilometres north of Murmansk. Most of the Northern Fleet's surface vessels are based here, including the nuclear powered battle cruisers. None of the nuclear submarines are regularly based at Severomorsk.

metres north east of Severomorsk, has a large repository for missiles, including missiles with nuclear warheads.³⁸⁸ In 1984 there was a powerful explosion here followed by a fire in which a large number of missiles were totally destroyed. The fire was rapidly extinguished and did not spread to the nuclear missiles.³⁸⁹

4.8

Gremikha

Gremikha is the easternmost of the Northern Fleet naval bases on the Kola Peninsula, and lies about 35 kilometres east of the mouth of the Murmansk Fjord, just at the borderline for an ice-free harbour during the winter months. This base is also known as Murmansk-140 and Iokanga. Other places with direct connection to the base are Yagernaya and Ostrovny (residential quarters for the submarine officers). The only access to the base is either by ship or by helicopter, and during winter storms, the base is completely isolated. The pier facilities are located on the mainland inside the Iokagansky islands Chai-chy, Vitte, Salny, Medvezhy and Pervy Osuzhnoy. There is a natural canal 500-600 meters wide between the islands and the mainland. The total length of the pier facilities at Gremikha is 6 770 meters.³⁹⁰

Gremikha was first settled in the 1800s. In the 1930s,

it was the location of a prison camp for political prisoners. Ever since the outbreak of World War 2, it has been a naval base, although it did not serve as a submarine base until after the war when conventional submarines were posted here. The first Russian nuclear submarine (K-3) visited Gremikha in July 1962 on its return from the North Pole, and was received on its arrival by the General Secretary for the Central Committee of the Communist Party, N. S. Krushchev.³⁹¹ In 1968, a squadron of nuclear submarines of the Project 658 - Hotel class was posted to the base at Gremikha, and in 1974, a group of Project 667 A - Yankee class submarines was added. With the arrival of the Yankee class submarines, the base was developed further, including a new quay facility. A floating repair yard was also constructed for the nuclear submarines at the base. By the 1980s, the base had a population of 30 000; this figure has fallen by about 10 000 in more recent years.³⁹² Today, there are a few operational nuclear submarines based here plus another 15 that have been taken out of service.³⁹³ Four of them are Project 627 A - November class; one is a Project 658 - Hotel class, and eight are of the Project 671 - Victor class. The nuclear fuel has not been removed from any of the vessels; thus there are a total of 26 reactors still containing their nuclear fuel that have been laid up at Gremikha.³⁹⁴ Tunnels have been built in Gremikha for the purpose of concealing submarines, but it is not known whether or not these tunnels have been taken into use.

388 Krasnaja Zvezda, September 21, 1995.

389 Nilsen, T., and Bøhmer, N., *Sources of Radioactive Contamination in Murmansk and Arkhangelsk Counties*, Bellona Report No. 1 1994.

390 Ries, T. and Skorve, ., *Investigating Kola, A Study of Military Bases using Satellite Photography*, Oslo 1987.

391 Mormul, N., Note, 1995.

392 Berlin, J. et al., *The Flying Dogs Island*, 1993.

393 Paper presented at conference on *Problems in decommissioning and dismantling of nuclear submarines*, Moscow, June 19-22, 1995.

394 Kværner Moss Technology AS, *Disposal of Russian Submarines*, January 19, 1996.

4.8.1 Storage of solid radioactive waste³⁹⁵

Gremikha has one storage facility for solid radioactive waste. The facility measures 15 m x 20 m and is situated right beside dry dock no. SD-10. Containers and other contaminated equipment are stored here in the open. Certain of the radioactive contaminated items that are stored here are so large that they cannot be transported away with the available equipment; subsequently, these items have not been packed in with any protective covering or shielding around them. Nor is the storage area secured against run-off.

4.8.2 Storage of liquid radioactive waste

Liquid radioactive waste is stored on land in underground tanks. These tanks were originally built as part of a facility to process liquid radioactive waste, but just like a similar facility in Andreeva Bay, this facility has never been utilised. The storage tanks are constructed of concrete covered on the inside with stainless steel and do not satisfy present day requirements or standards. Nonetheless, a total of 2 000 m³ of liquid medium level radioactive waste with an activity of 370 kBq/l (10⁻⁵ Ci/l.) is stored in these tanks. The tanks have been set inside a number of buildings, and so far, there are no reports of any leakage from them. In addition to the tanks, liquid radioactive waste is also stored in a service ship of the Project 1783 A - TNT (Vala class) as well as in some PEK-50 type floating tanks. There is little in the way of liquid radioactive waste being generated today since the nuclear submarines are no longer refuelled at the base.

4.8.3 Storage of spent nuclear fuel assemblies³⁹⁶

Gremikha is the only Northern Fleet naval base where liquid metal cooled reactors can be refuelled and the spent fuel taken from them is stored on base. Spent nuclear fuel from pressurised water reactors is also stored here. Spent nuclear fuel assemblies are stored in Gremikha at three different places, but all three are connected to the dry dock SD-10. During World War 2, this dock was blasted into the mountain from the seaward side. The first generation of nuclear submarines was refuelled here, but was later rebuilt to accommodate refuelling activities for the Project 705 - Alfa class submarines with their liquid metal cooled reactors. There are two cranes at the dock with a lifting capacity of 10 and 75 tons, respectively. On the inside, the dock is covered with concrete and a roof has been built over it. The water in the dock can be pumped out once the submarines have come in. Repair work and refuelling activities can be undertaken once the water has been pumped

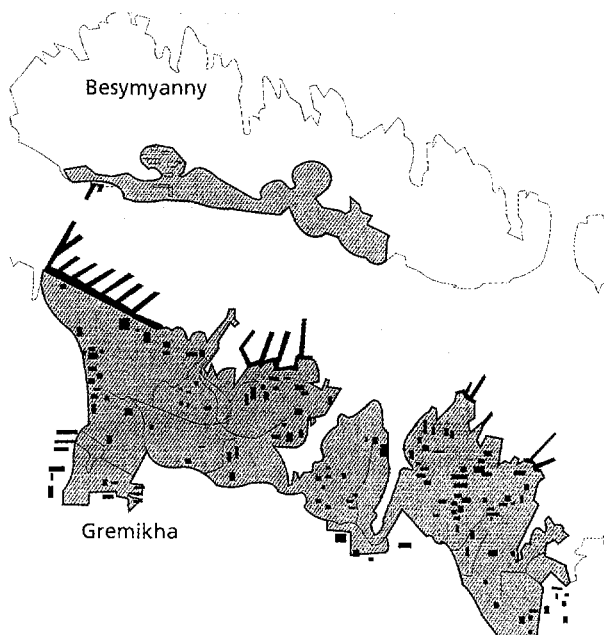

Map 5. The naval base Gremikha lies easternmost on the Kola Peninsula, and there are both active and laid up submarines here. There is also a storage facility for spent fuel assemblies and for solid and liquid radioactive waste.

ped out. The cranes are sufficiently long such that the spent fuel removed from the reactors can be transferred directly to the fuel storage tanks. The entire area around dry dock SD-10, including the storage facilities for solid and liquid radioactive waste are known as "Object 925".

The first storage facility for spent nuclear fuel is a storage pool, and is called "Building 1". Construction of the facility began in 1960, and it was here that spent nuclear fuel from the pressurised water reactors of the first generation of nuclear submarines, Project 627 - November class was stored. The facility has been divided into four separate pools with a common shielding around all of them. These four storage compartments are made of concrete, and are covered with metal on the inside. Each of the compartments are 68.44 m³ and were intended to hold two reactor cores. The total capacity of the four compartments was approximately 1 500 fuel assemblies, corresponding to a total of eight reactor cores. Unlike Building 5 at Andreeva Bay, where five to seven reactor cores were stored together, the reactor cores at Gremikha were stored separately. The fuel assemblies were attached to a console and hung down into the water. The storage pools were built underground and are 4.8 meters deep. Each of the fuel assemblies weighed 20 kilograms, and were stored underwater with a minimum coverage of 3 meters of water over the top of each one. When water leakage from the storage pools was discovered in 1984, the spent nuclear fuel assemblies were removed and transported on Northern

³⁹⁵ Information on the storage of solid and liquid radioactive waste has been given by Oleg Kaplyov, Department of Nuclear Safety, Murmansk Shipping Company, 1995.

³⁹⁶ Information in this section (unless otherwise indicated) is based on conversations held with workers involved in cleanup work at the storage facilities.

Fleet service ships to Murmansk. Here they were transferred to trains and forwarded to Mayak. However, only three of the pools were completely emptied. Ninety five damaged fuel assemblies were transferred to the fourth pool where they remain in storage today.

The second facility for spent nuclear fuel assemblies is an outdoor one without any form of protective covering or shielding. There are approximately 110 type TK-11 (type 6) containers being stored here holding an approximate total of 700 spent nuclear fuel assemblies. The containers have been set down quite haphazardly in an open area surrounded by a broken concrete wall. One of the containers is in very poor condition, having been outdoors and withstanding the elements for over 30 years. The containers hold spent nuclear fuel from the earliest submarine refuelling activities at Severodvinsk early in the 1960s. Today, there are no service ships with the specially designed storage hold necessary to transport the spent fuel away from Gremikha. The storage facility is situated about 30 m from dry dock SD-10.³⁹⁷

The third storage facility for spent nuclear fuel contains reactor cores from submarines with liquid metal cooled reactors. In the middle of the 1960s, two reactor cores from the Project 645 ZhMT) submarine K-27 were placed in the innermost parts of dry dock SD-10. These reactor cores had been removed from the submarine at Severodvinsk and transported to Gremikha. The two reactor cores are still in concrete containers in storage facility 2B today. Later it was decided to defuel submarines with liquid metal cooled reactors at Gremikha.

As a result of this decision, dry dock SD-10 was modified early in the 1980s from a facility that specialised in the refuelling of first generation submarines to one handling the defuelling of submarines with liquid metal cooled reactors (Alfa class). As part of the modifications, storage facility 2B was enlarged and a new storage tank, 1A, was built. Today the total capacity of the two storage areas is 10 reactor cores, two in storage facility 1A, and eight in storage facility 2B.

The procedure for removing spent nuclear fuel from liquid metal reactors was different to that used when handling fuel from submarines with pressurised water reactors. A container was hoisted out over the open reactor compartments of the submarines (Project 705 - Alfa class.) The reactor core was then heated up with steam, and the fuel assemblies were drawn up into the container using vacuum pressure. The container would be left hanging over the reactor compartment for a time until the liquid metal (a lead bismuth mixture) that had been drawn up with the fuel assemblies could run down into the reactor again. After that, the container was sealed and transferred to storage facility 1A with the help

of a 75 ton crane. After two months of storage in storage tank 1A, the container was transferred to storage facility 2B.

As of today, four submarines of the Project 705 - Alfa class have been defuelled at Gremikha. These four reactor cores, along with the two from K-27, are being stored in storage facility 2B. Hence there is a total of six reactor cores in Gremikha from submarines with liquid metal cooled reactors. There are also three more Project 705 - Alfa class submarines here still containing their nuclear fuel (one active, and two inactive). It is not known what will be done about the nuclear fuel that remains on board the vessels. Furthermore, on December 21, 1994, it was decided that the reactor compartment from the submarine K-64, fabrication no. 900, should be stored at Gremikha. This reactor section is filled with furfurool, and it is impossible to remove the fuel from it.³⁹⁸

Today, neither refuelling nor defuelling of nuclear submarines can be undertaken at Gremikha because the dry dock SD-10 is leaking, and the equipment in the dry dock is worn out. There were plans to repair the facility in October 1994, but nothing was done because the work team was constantly drunk.

Work is now in progress to build transport containers suitable for fuel assemblies from liquid metal cooled reactors. These will be used for transport from Gremikha in 1998.³⁹⁹

Accident at the storage facility for spent nuclear fuel assemblies

In 1984, it was discovered that the water level in one of the four storage pools for spent nuclear fuel assemblies in Building 1 had dropped. (At this time, fuel assemblies from the first generation of nuclear submarines were being stored in the pool.) Although more water was immediately poured into the pool, there was an increased activity in the water which was running out the dry dock SD-10, as much as 370 Bq/l (10^{-8} Ci/l). Upon closer inspection it was discovered that there were about 30 tons of radioactive water leaking out of storage pool no. 1. The decision was made to cease using the facility and to transport all of the fuel assemblies away from Gremikha, all except approximately 100 fuel assemblies which had been destroyed. These were transferred to storage pool no. 2 which was in better technical condition.

At this point, fuel assemblies from four reactor cores were being stored in the storage pools. After the pools had been emptied, it was asserted that the leak had been caused by a crack in the pool which had come as a result of defective welding in one of the consoles that held the

397 Oleg Kapylov, Nuclear Safety Department, Murmansk Shipping Company.

398 Symakov, R. A., *Malakhit* Designing Company, lecture presented in the paper *Problems in the Decommissioning of Nuclear Submarines, and Protection of the Environment in the Arctic Regions*, Severodvinsk, March 15-16, 1995.

399 Petrov, O., *Radioactive Waste and Spent Nuclear Fuel in the Navy of Russia*. 1995.

spent fuel elements. Examinations of the other pools indicated that a number of the fuel assemblies had cracked.

Each assembly weighed 20 kilograms, and the task of removing them from the storage pools was far easier than the clean-up of storage building no. 5 at Andreeva Bay. The 95 fuel assemblies that had cracked were transferred to storage pool no. 2 where they remain today. There are no existing plans for how to store or transport them in the future. The condition of storage pool no. 2 is now critical, for there is a considerable

collection of fission products in the fuel assemblies. The contaminated ground in the dry dock has been collected and packed into containers. These containers are now stacked in the same open area where the solid radioactive waste is being stored.

Further use of the storage facility at Gremikha is presently prohibited under a directive from the Ministry of Defence's Department for Radiation Safety. Storage pools no. 1, 3 and 4 are now thoroughly dry, but they have not been decontaminated.

**NEXT PAGE(S)
left BLANK**

Naval yards

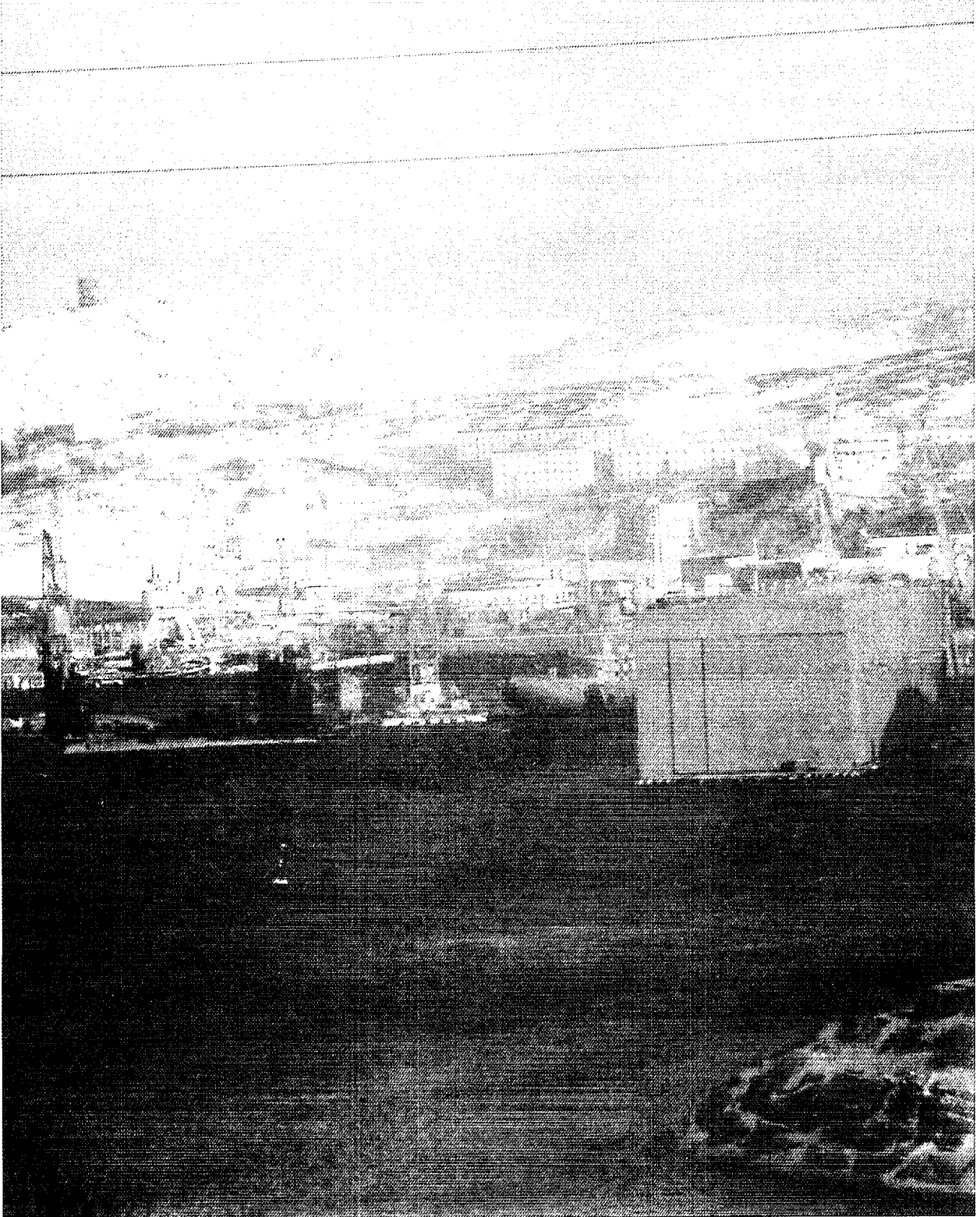

Naval yards

Including Sevmash, there are six naval yards in Murmansk and Arkhangelsk counties. Sevmash is the only yard that constructs nuclear submarines. As part of servicing the submarines, the yards carry out operations in defuelling, refuelling, general maintenance, repair and work in the dry dock where the vessels' hulls and structures are attended to. In addition to the naval yards, there are several floating docks stationed at the various bases. Each of the floating docks has a crew of 100 men whose primary task is the servicing of nuclear submarines between missions.⁴⁰⁰ The Northern Fleet also has a number of service ships which assist in conducting minor maintenance and repair work on the submarines. The first refuelling of a Russian submarine was carried out at Severodvinsk in 1961 (K-3).⁴⁰¹

In the 1960s, naval yard no. 35, Sevmorput, was rebuilt to accommodate nuclear submarines.⁴⁰² Simultaneously new yards were built and existing facilities were expanded, including yards no. 85 Nerpa and no. 10 Shkval.⁴⁰³

5.1

Economy and organisation

The naval yards Sevmash, Zvezdochka and Nerpa are all subordinate to the Ministry of Shipbuilding, whereas the Sevmorput, Shkval and Safonovo yards are run by the Northern Fleet and are thereby subject to the Ministry of Defence. The naval yards with their complex infrastructure were products of the cold war, and they now face

serious economic challenges. State economic support to the naval yards has been reduced as the number of nuclear submarines taken out of service has increased.

Until 1989, the large Zvezdochka yard in Severodvinsk serviced four nuclear submarines a year, whereas during 1992-1993, only one submarine was serviced.⁴⁰⁴ In 1994, no submarines were serviced at all. In 1994, the Sevmash yards accepted official commissions to construct new nuclear submarines amounting to 300 billion roubles, but only 29 billion was actually transferred to the shipyard.

Due to the lack of funds, the Northern Fleet naval yards no longer carry out complete overhauls of nuclear submarines, but are only doing hull maintenance.⁴⁰⁵ This constitutes the bulk of work carried out by Navy-run yards⁴⁰⁶ along with ensuring that the decommissioned submarines remain buoyant.⁴⁰⁷ For each of the individual submarines, it is decided if there are enough economical resources to remove the spent nuclear fuel.⁴⁰⁸

The Sevmorput and Nerpa yards also accept commissions from the Russian commercial fleet.⁴⁰⁹ The Zvezdochka yard constructs new ships for foreign customers,⁴¹⁰ including tugs, fishing boats and barges.⁴¹¹ There may also be potential opportunities of large construction projects for the Zvezdochka and Nerpa shipyards in connection with the proposed development of oil and gas fields in the Barents and Kara Seas.⁴¹² The yards subject to the Ministry of Shipbuilding are therefore in a more viable economic situation than the yards sponsored by the Northern Fleet.⁴¹³ In fact, there are plans to merge shipyards No. 35 Sevmorput and No. 82 Safonovo in order to improve the economic situation for the Northern Fleet yards.⁴¹⁴

400 Mormul, N., Note, 1995.

401 Osipenko, L. G., Shiltsov, L. M. and Mormul, N. G., *Atomnaya Podvodnaya Epopeya*, Moscow 1994.

402 Publicity brochure from naval yard No. 35, Sevmorput, 1992.

403 *Morskoy sbornik*, no. 8 - 1995.

404 *Severny Rabochy*, March 25, 1995

405 *Murmansky vestnik*, January 11, 1995.

406 *Murmansky vestnik*, March 11, 1995.

407 *Murmansky vestnik*, January 11 1995.

408 *Morskoy sbornik*, no. 7 - 1995.

409 *Rybny Murman*, June 23 - 29, 1995.

410 Government decree 514, July 24, 1992.

411 *Na Strazhe Zapolyarya*, June 24, 1995.

412 *Severny Rabochy*, July 17, 1993.

413 *Polyarnaya Pravda*, February 28, 1995.

414 *Murmansky vestnik*, March 15, 1995.

Towards the end of 1984, the Russian government passed Decree No. 1399 in which measures for improving the fiscal situation of Navy shipyards and other yards within the military-industrial complex are outlined. A limited company known as *The Russian Fleet* was established in which the various naval yards are represented. Its primary objective is to get the government to adopt practical measures by which the economy of the Navy yards may be improved. Today the shipyards are experiencing great difficulty in obtaining payment for work completed on the Navy's behalf, even though the work in itself is less comprehensive than before.

In December 1995, employees of Navy yard No. 10 Shkval ran a blockade to prevent a recently repaired nuclear submarine from departing until back pay from August 1995 had been received. The Northern Fleet responded by threatening to cut the Polyarny electrical grid serving the workers' homes. The blockade was broken when the demands of the workers were finally met.⁴¹⁵ In January 1996, the Northern Fleet still owed 40 billion roubles in wages for workers at the Kola and Severodvinsk shipyards.⁴¹⁶

The financial problems of the Northern Fleet are also beginning to have an impact on radiation safety measures for nuclear submarines moored at the various naval yards. There is no money allocated for maintenance or for the necessary expansion of the storage facilities for liquid and solid radioactive waste. At the Nerpa, Shkval and Severodvinsk shipyards, solid radioactive waste is now stored unshielded out in the open, with no protection against runoff.⁴¹⁷

5.2

Navy yard no. 10 - Shkval ⁴¹⁸

Navy Yard no. 10 is situated near the town Polyarny outermost on the western side of the Murmansk fjord. The first naval yard, No. 1078, was established here on August 20, 1935, when the floating workshop *Krasny gorn* was towed there. Prior to this, only the fish processing plant *Polyarnoye* was situated here. During World War 2, these workshops were used for servicing naval vessels; after the war, several shore-based installations were built and the quays were lengthened. In August 1950, the facility was renamed Navy yard No. 10 Shkval, to be dedicated exclusively to military vessels, primarily submarines. As the first nuclear powered sub-

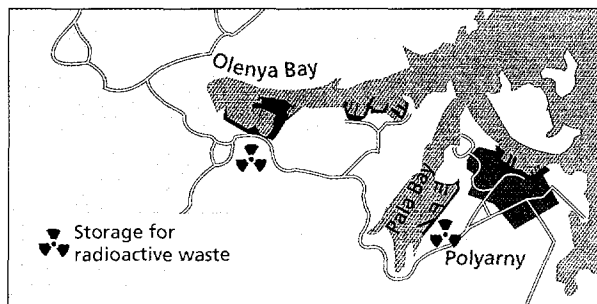

Map 6. The naval yards *Shkval* and *Nerpa* are situated on the western side of the mouth of the Murmansk Fjord.

marines were delivered to the Northern Fleet at the end of the 1950s, the yard was modified for the docking and repair of these vessels. Tenders, service ships and dry docks were acquired, including the floating dock PD-63. Around 1970, the yards were reorganised and partially expanded in order to handle the second generation of nuclear submarines.

At the present time, there are two covered floating docks at the yard constituting a total quay length of 700 m. The yard has a surface area of 41 330 m² (446 000 sq. ft.). There are approx. 3000 employees at the yard. The nearby town of Polyarny has just under 30 000 inhabitants.

From 1962 until 1993, repair and maintenance operations have been carried out on approximately 250 first generation nuclear submarines and about 60 second generation vessels. An additional 1515 naval vessels have been repaired in dry dock, including some third generation nuclear submarines. At present, Yard no. 10 Shkval is the only Kola based naval yard capable of accommodating and servicing both second and third generation submarines, and has at its disposal the necessary equipment for refuelling naval reactors. However, no decision has been made as to whether refuelling operations will continue to take place here in the future.

The Shkval yard is capable of processing 3-4 nuclear submarines at the same time. At the moment of writing (March 1996), one nuclear submarine (fabrication number 638), a type 326 M transport for spent nuclear fuel and the tanker *Amur* are moored at the yard awaiting repair. There are also seven nuclear submarines laid up here. Of these seven, four are first generation submarines waiting to be defuelled prior to being dismantled. The remaining three vessels are Project 671 - Victor-class submarines, two of which (K-371 factory no. 802 and K-488 factory no. 804) have not been decommissioned pending a decision on what to do with them. There is no money to repair these submarines, so they will pro-

415 Lee, R., *State of the Russian Navy data page*, revised January 9, 1996.

416 *Polyarnaya Pravda*, January 24, 1996.

417 Steblin, P. G., director Nerpa yards, presentation of the paper *Difficulties in decommissioning of submarines and protection of the northern environment*, Severodvinsk, March 15 - 16, 1995.

418 Most of this is taken from *Morskoy sbornik*, no. 8, 1995.



The naval yard *Shkval* lies close to the city of Polyarny, and it is here that maintenance work on the laid up submarines is carried out as well as the servicing of second and third generation nuclear submarines that remain in service. The shipyard has a larger storage facility for solid radioactive waste and two floating tanks containing liquid radioactive waste. The nuclear submarine K-192 is also moored here with its melted down nuclear reactor following an accident in 1989.

bably be decommissioned. In the meantime, the task of the naval yard is to keep the seven submarines afloat.

In June 1989, the reactor of K-192, formerly K-131 (Project 645 - Echo-II class), one of the first generation submarines, was seriously damaged. An uncontrolled chain reaction occurred in one of the two reactors, destroying the fuel assemblies. The submarine was laid up at the Vidyaev base in Ara Bay until 1994 when it was moved to Shkval, for Vidyaev lacked the necessary facilities to keep the submarine afloat. Because the nuclear fuel in one of the reactors is damaged, it cannot be removed using the normal procedure. The fuel in the undamaged reactor also remains untouched due to the high levels of radiation inside the reactor compartment; however, this reactor is scheduled to be defuelled when radiation levels have dropped.

In past years Shkval Shipyard has dismantled one first generation nuclear submarine, the hull plates of which are still in the yard. There are also plans to dismantle other decommissioned submarines of the first and second generations here,⁴¹⁹ but no funds have been allocated to pay for the work.

5.2.1 Storage of radioactive waste

Solid radioactive waste is placed into containers and stored in an area specifically dedicated to this purpose. Two hundred containers and some large pieces of contaminated material have been placed outside the actual storage site which is full. There are plans to expand the storage facility or build an additional one, but so far no money has been earmarked for this.

Liquid radioactive waste is stored in two floating

tanks at the quay. The capacity of this storage is approximately 150 m³ (5300 cu. ft.)

There are plans for establishing a storage facility for spent nuclear fuel in an existing tunnel near the shipyard, but no firm decision has been made. While the yard does possess equipment for the removal of fuel from both operational and inactive submarines, it is currently not in use.

Like the other shipyards of the Northern Fleet, yard No 10 Shkval faces considerable economic problems. By January 1995, the yard was working to 67% of capacity, with 40.6 billion roubles outstanding.

5.3

Navy yard no. 82 - Safonovo

Navy yard no. 82 Safonovo is a Northern Fleet ship repair yard. It is situated on the eastern side of the Murmansk fjord between Severomorsk and Murmansk. The yard is comprised of a number of large shore-based workshops and two large dry docks. One of these dry docks was purchased from Germany in the early 1970s, the other from Sweden in 1980.⁴²⁰ The latter is the largest dry dock on the peninsula, with a loading capacity of 80 000 tons. It is also used for hull maintenance on Project 941 - Typhoon-class submarines. Safonovo is also capable of repairing other strategic submarine classes and nuclear powered surface vessels. The dry dock there has been used for hull maintenance of the civilian nuclear powered container ship *Sevmorput*.⁴²¹

419 Steblin, P. G., director Nerpa yards, presentation of the paper *Difficulties in decommissioning of submarines and protection of the northern environment*, Severodvinsk, March 15 - 16, 1995.

420 Mormul, Note, 1995.

421 Nilsen, T., and Bøhmer, N., Sources of Radioactive Contamination in Murmansk and Arkhangelsk Counties. Bellona Report no.1 :1994.

5.4

Naval yard No. 35 - Sevmorput

Naval yard no. 35 Sevmorput is also a Northern Fleet naval repair yard located on the Murmansk Fjord in the Rosta district of Murmansk, between the nuclear icebreaker base Atomflot and the merchant harbour. Building commenced in 1936 and the yard opened for work in 1938.⁴²² Today it is one of the largest shipyards in north-western Russia.

In addition to several large workshops the yard operates two large dry docks.⁴²³ Until the end of the 1980s, the yard employed 5500 workers, but today the number of employees is much smaller. Due to a lack of military commissions, part of the yard has been privatised, and this part of the yard accepts commissions from the merchant fleet.

Sevmorput has been repairing first generation nuclear submarines since the close of the 1960s, and until 1991, the refuelling of nuclear submarines was also undertaken here. Although the normal time scale for refuelling nuclear submarines is two months, a number of the submarines at Sevmorput had to spend up to six months in dry dock when cracks were discovered in the hull of the reactor compartment. In 1991, county officials prohibited refuelling activities at this yard on the grounds of radiation safety concerns and the fact that the yard is located only a few hundred meters from more populous areas of the city. There are plans to resume refuelling activities at this yard, but only on the condition that safer technology is utilised.

There are presently two first generation Project 675 - Echo-II class and Project 658 - Hotel class submarines in the yard. The Project 658 - Hotel class submarine is scheduled to be defuelled.⁴²⁴ The main task for the Sevmorput yard is to keep these two submarines floating.⁴²⁵

5.4.1 Storage of radioactive waste

Sevmorput has an open air storage facility for solid radioactive waste, and low level waste is stored here in containers. Liquid radioactive waste is not stored at this yard, but is transferred to the Northern Fleet TNT type tankers.⁴²⁶

There is a storage facility for fresh nuclear fuel at pier 20, also known as no. 3-30, military unit no. 31326. Until recently, this facility was used to store fresh nuclear fuel for Project 671 - Victor-III-class submarines. However, in November 1993, three fuel assemblies

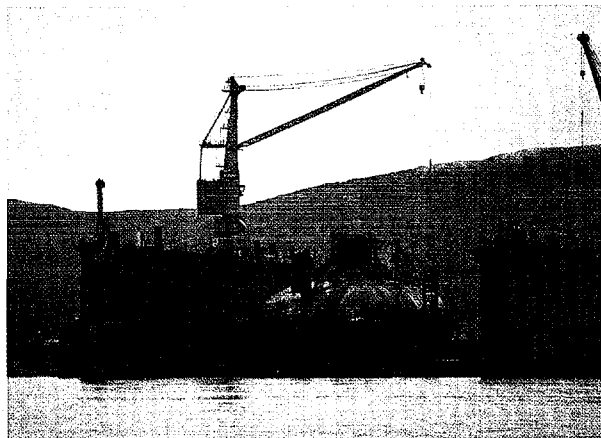

The naval yard Safonovo is located south of Severomorsk in the Murmansk Fjord and has several large floating docks similar to the one pictured here. In this photograph, maintenance work on the hull of a Typhoon class submarine is being carried out.



The naval shipyard Sevmorput is located in the Rosta township in the northern district of Murmansk. Spent nuclear fuel assemblies are transferred at the shipyard from Northern Fleet service ships to railroad cars which will transport them further to the reprocessing facility at Mayak Chemical Combine in the Southern Urals. Sevmorput also has a storage facility for fresh nuclear fuel.

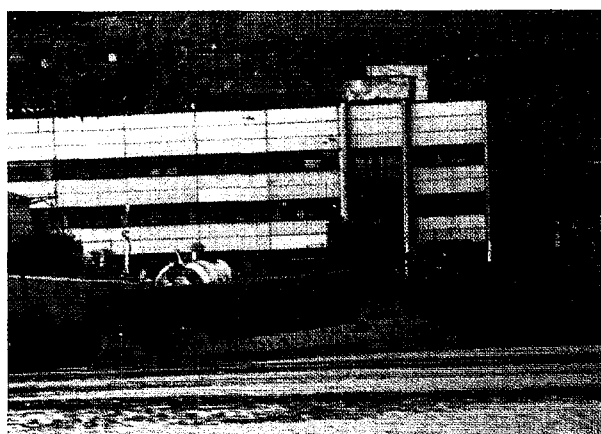

The Northern Fleet's India class (BS-203) rescue submarine with a Project 1837 deep submersible rescue vessel (DSRV) on deck photographed at Sevmorput. These DSRVs are mini submarines that can dive down to 2 000 metres to rescue the crew of a sunken submarine.

422 Description of Sevmorput in letter from vice director Vladimir Kozlovsky

423 Osipenko, L. G., Shiltsov, L. M. and Mormul, N. G., *Atomnaya Podvodnaya Epopeya*, Moscow 1994.

424 Murmansk Radio, September 1995.

425 Murmanskyy vestnik, January 11. 1995.

426 Oral information given by Sevmorput workers, spring 1995.

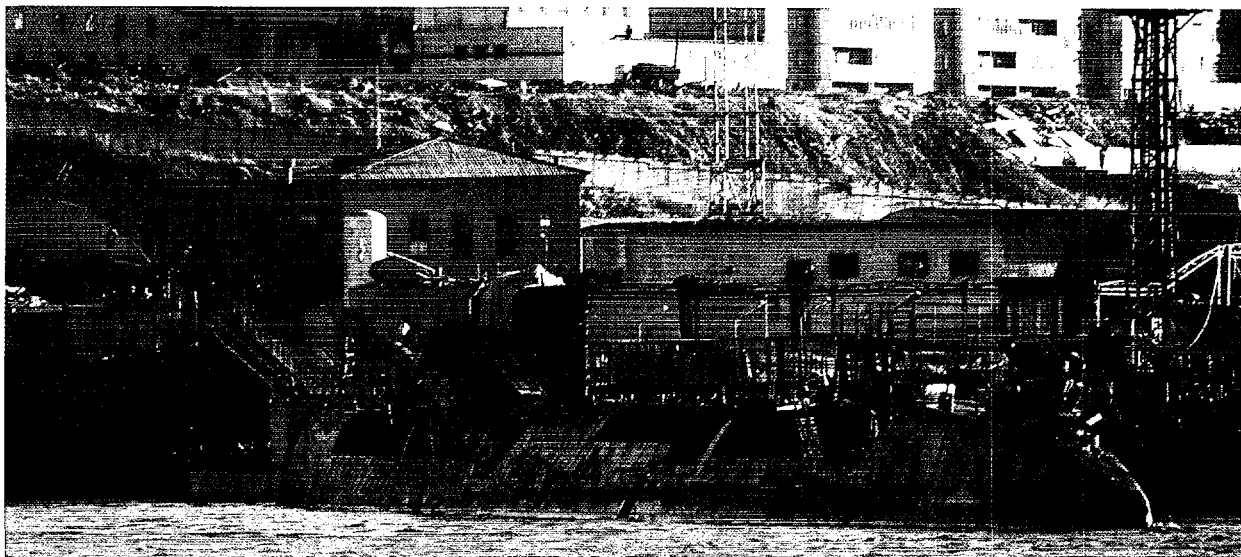

This Echo-II class nuclear submarine is moored at one of the piers at the naval shipyard Sevmorput only a few hundred metres away from the closest apartment buildings in the Rosta township. The submarine has two reactors on board. In 1991, the county authorities in Murmansk prohibited the removal of spent fuel assemblies from nuclear submarines at Sevmorput on the grounds that an accident during this type of operation could affect large parts of Murmansk and over half a million inhabitants.

were stolen from this storage facility, and security arrangements at the facility came under sharp scrutiny. It was said that even Murmansk potato bins were guarded better than the open air storage facility. As a result of the theft, all of the fuel assemblies stored here were transferred to another Northern Fleet facility.⁴²⁷

5.5

Naval yard No. 85 - Nerpa

Naval yard No. 85 Nerpa is situated in the bottom of Olenya Bay, a few kilometres west of Polyarny. Nerpa was initially subject to the Ministry of Shipbuilding, but was later transferred to *Goskomoboronprom*, the state committee for military industry. Construction of the yard commenced in 1970 by direct order of D. V. Ustinov, then vice-chairman of the Soviet weapons ministry and later Soviet Minister of Defence.⁴²⁸ The town of Snezhnogorsk, also known as Vyuzhny or Murmansk-60, is located approximately 5 kilometres south-west of Nerpa, and was established at the same time as the shipyard.

The principal task of the Nerpa yard is the service and repair of second generation nuclear submarines. Earlier, the yard was responsible for the removal of the

reactor control rods and preparation of reactors prior to the insertion of fresh fuel assemblies.⁴²⁹

Nerpa has one dry and one floating dock, and it also has equipment for transferring spent fuel to the specially constructed Project 2020 - Malina-class ships.

Due to a lack of military assignments and the inability of the Northern Fleet to pay for completed work, the yard has also been accepting commercial orders since 1993. A few small fishing boats have been built here, and the shipyard's directors hope to secure further new business in connection with the forthcoming expansion of the oil and gas industry in the Russian Arctic.

The Nerpa yard furthermore dismantles second generation nuclear submarines. So far, two submarines have been completely dismantled: a Project 671 - Victor-I-class (K-481, factory no. 615) and a Project 670 M - Charlie-II-class (K-479, factory no. 903).⁴³⁰ A new land based dry-dock with special equipment for the dismantling of submarines is under construction at the shipyard, and will be equipped with machinery manufactured in the United States, including a *Hughes Aircraft Systems International* plasma torch for cutting tempered steel hull plates.⁴³¹ The dock should have been finished in 1996, but completion will be delayed by a few years.⁴³² Building costs are estimated at 270 billion roubles.⁴³³

427 *Izvestia*, 12 May 1995.

428 Mormul, N., Note, 1995.

429 Steblin, P. G., director Nerpa yards, presentation of the paper; *Difficulties in decommissioning of submarines and protection of the northern environment*, Severodvinsk, 15 - 16 March, 1995.

430 Russian Government decree no. 514, July 24, 1992.

431 *Rybny Murman*, February 2 - 8 1996.

432 Steblin, P. G., director Nerpa yards, presentation of the paper; *Difficulties with decommissioning of submarines and protection of the northern environment*, Severodvinsk, March 15 - 16, 1995.

433 *Komersant Daily*, June 29, 1995.

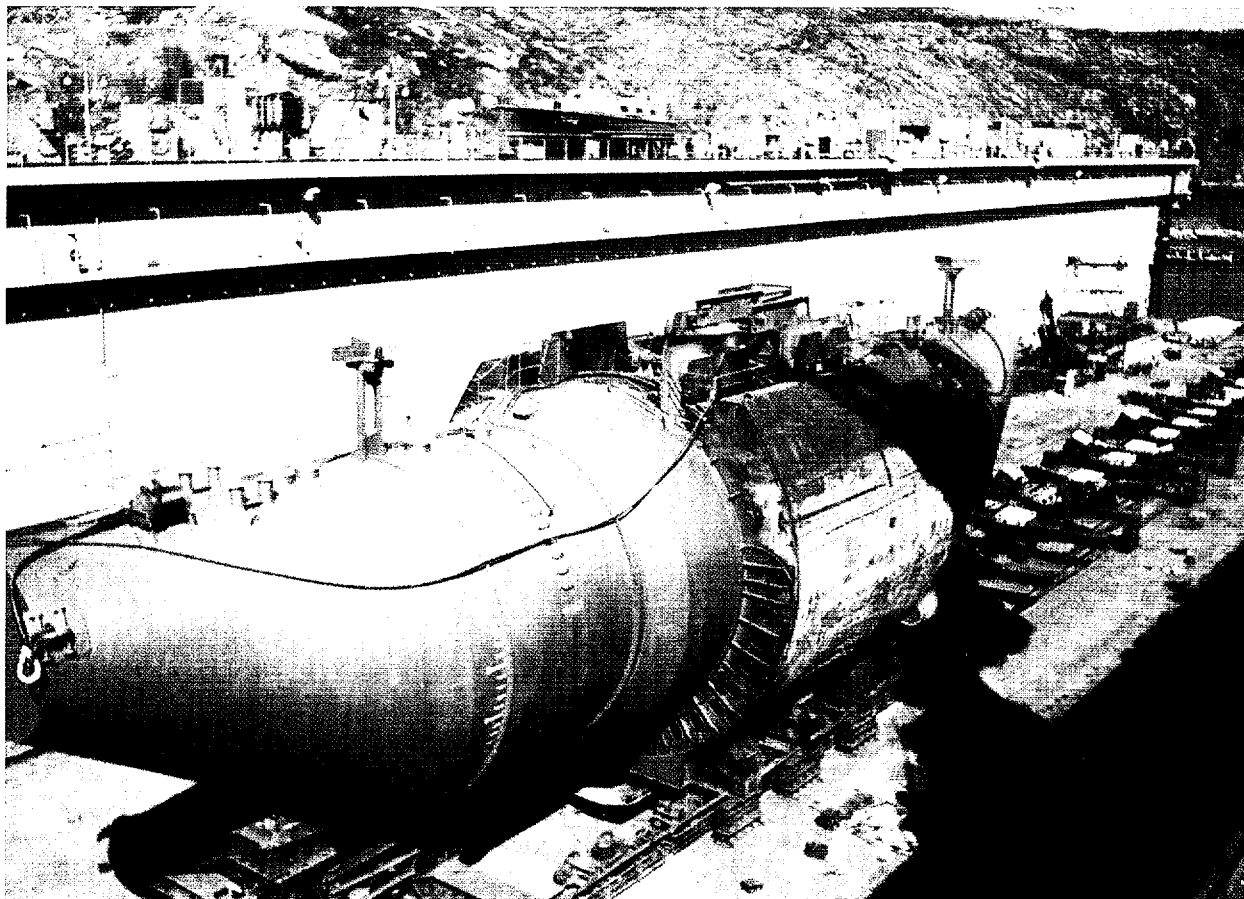

This is the reactor compartment from a Victor-I class submarine at the *Nerpa* naval yard. The entire submarine is taken into a land-based dry dock such as this one where the work to cut out the reactor compartment is carried out. Before the reactor compartment is removed from the submarine and set afloat again, all holes, pipes and cable lines are resealed so that radioactively contaminated components from the reactor section cannot come into direct contact with the sea water.



Work on the new dry dock at *Nerpa* shipyard was due to be completed in 1996, but because of economic difficulties, the project has been postponed.

Storage for radioactive waste

There is an open air storage facility for solid radioactive waste within the shipyard's compound. This facility has a surface area of 500 m² (5400 sq. ft.) and is located 100 meters from the sea. Presently there are 200 m³ (7000

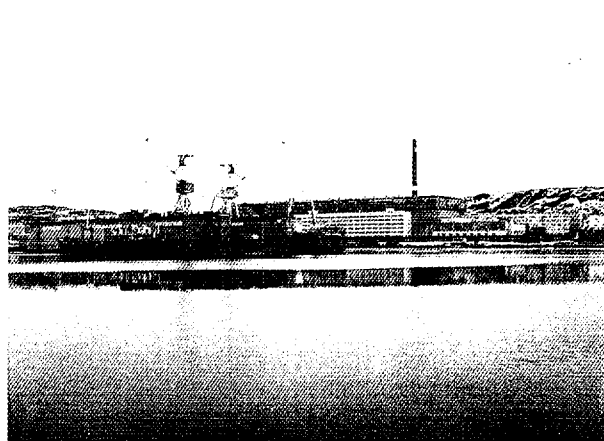

The naval shipyard *Nerpa* is situated innermost in Olenya Bay and carries out service and maintenance operations on both active nuclear submarines and civilian vessels. Decommissioning operations on second generation nuclear submarines is also undertaken here.

cu. ft.) of solid radioactive waste weighing 250 tons in storage here inside airtight containers. In earlier years, this waste was collected by Northern Fleet ships and dumped into the Kara sea, but it is now four years since waste was last collected from the facility. Hence it is

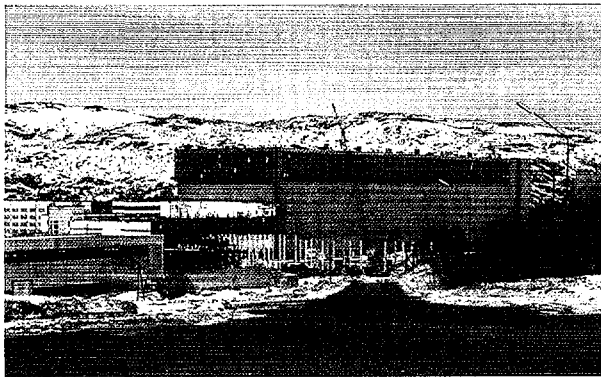

Second generation nuclear submarines will be decommissioned both in this land-based dock and in a new dry dock that is presently under construction. Some of the equipment in the new dry dock includes American plasma cutters to cut through the pressure hulls of the submarines.

In this photograph, work is underway to decommission a Delta class nuclear submarine at the naval shipyard *Nerpa*. On the other side of the bay, at the leftmost edge of the picture, is one of the Northern Fleet's Project 2020 - Malina class service ships used for storing spent fuel assemblies from the nuclear submarines. The vessel is listing to one side and is not approved for the storage and transport of spent fuel assemblies.

full, and there are plans to expand it to make room for additional containers.⁴³⁴

Approximately 70 m³ of liquid radioactive waste is being stored at a shore-based storage tank facility, and liquid radioactive waste is also stored on two type PK-15 barges, each of which has a capacity of 50 m³ of waste. Northern Fleet TNT tankers are also utilised for the storage of liquid radioactive waste.

Plans exist for the building of a small subterranean nuclear power station in Kut Bay 700 meters away from the *Nerpa* yard. According to project plans (the project is known as PATES-300), the power station will be blasted 50 meters into rock. The plant will have a pressurised water reactor (PWR) developed by the *Rosenergoatom* Research Institute in St. Petersburg. Building costs are estimated at 200 million USD, with construction to be completed by 2001. However, at this time the plans exist only on paper. The *Nerpa* shipyard will operate and service the power station which is to supply electric power to the *Nerpa* yard, area naval bases and the towns of Snezhnogorsk, Polyarny, Belokamenka, Gadzhievo, Olenya Bay and Vidyaevo. The expected output of power is 300 MW and it is the proposed enlargement of the *Nerpa* yard which increases the need for electric power. Decommissioned submarine reactors have also been considered as a source for electricity production.⁴³⁵

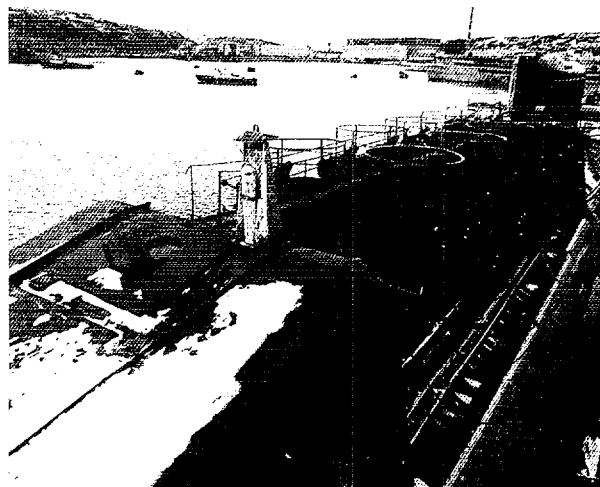
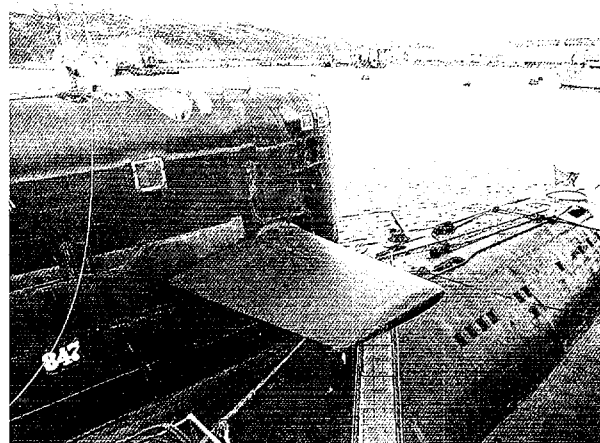

5.6

The Severodvinsk naval yards

In 1936 the town of Sudostroy was built by decree of Joseph Stalin. It was renamed Molotovsk in 1938 and received its present name, Severodvinsk, in 1958. Severodvinsk lies on the White sea 35 kilometres west of Arkhangelsk. The town was built by Gulag prisoners and on average, had a prisoner population of 60 000. Conditions in the prison camp were very hard, and in the years from 1936 to 1953, approximately 25 000 Gulag prisoners died here.⁴³⁶

Now a town of 210 000 inhabitants, Severodvinsk has been a closed city since 1936, with the exception of a brief period from 1992 to 1993. Visitors to the town today require a security clearance.⁴³⁷ The town grew up around the two large naval shipyards *Sevmash* and *Zvezdochka* which are located on the northern edges of the city and cover an area of 15 square kilometres. These are the largest naval yards in Russia and nuclear

434 Visit at the *Nerpa* yard, Spring 1995..

435 *Barents News*, 1995.

436 *The Rose Isles of the White Sea*, Severodvinsk, 1992.

437 Note from Rune Castberg, The Fritjof Nansen Institute, 1994.

submarines are both built and serviced here. Since 1992, the Sevmash shipyard has been the only one to build nuclear submarines for the Russian Navy,⁴³⁸ while much of the work of servicing or dismantling them is undertaken at Zvezdochka.

In accordance with a governmental decree of 1992, the Severodvinsk yards have served as the main centre for the decommissioning of nuclear submarines.⁴³⁹ Sevmash, which previously was dedicated solely to new construction projects, now also undertakes the decommissioning and dismantling of submarines with titanium hulls. At Zvezdochka, Project 667 A - Yankee class and 667 B - Delta-I class submarines are decommissioned, and the shipyard also repairs and upgrades the submarines already in service. Zvezdochka also has facilities for the removal and temporary storage of spent nuclear fuel. Each year 300 operations with an inherent risk of radiation are performed at the Severodvinsk naval shipyards; this number represents a sharp reduction from the earlier figure of about 1000 operations a year.⁴⁴⁰

The Northern Fleet operates the Belomorsk naval base located adjacent to the yards and it is here that crew members for new naval vessels are trained.

5.6.1 Storage of solid radioactive waste.⁴⁴¹

There are four relatively large storage facilities for solid radioactive waste in Severodvinsk. Three of them are located within the shipyards, while the fourth is located outside the city itself. In all, these repositories contain 12 530 m³ solid radioactive waste,⁴⁴² comprising a total of 4 620 tons.⁴⁴³

At Zvezdochka, there is an incinerator for the disposal of solid radioactive waste. It was opened at the beginning of the 1980s, and can process 40 kg an hour of solid waste. It is mostly used for the destruction of rags and clothing.

Until 1991, most of the solid radioactive waste generated at Severodvinsk was dumped in the Kara sea. At times, radioactive waste from the Zvezdochka yard has even been dumped at the municipal landfill outside Severodvinsk in complete disregard of regulations. On those occasions where this has been discovered, the waste has been retrieved and returned to the Zvezdochka storage sites.⁴⁴⁴ Severodvinsk generates about

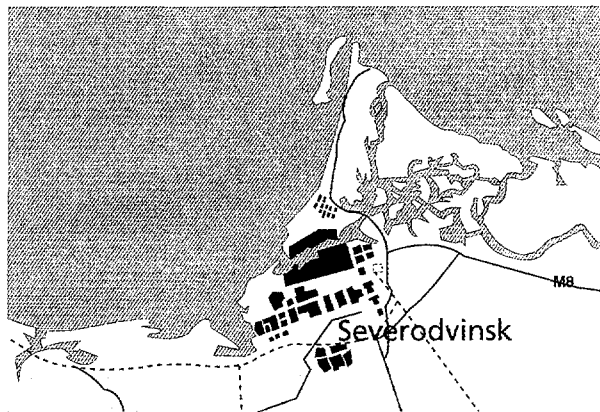

Map 7. Severodvinsk.

520 m³ of solid radioactive waste a year,⁴⁴⁵ most of which comes from the Zvezdochka yard during the servicing of nuclear submarines. This figure is expected to increase substantially as increasing numbers of submarines are dismantled.

Mironova Heights - storage repository for solid radioactive waste⁴⁴⁶

Mironova Heights are located 12 kilometres south-west of the town of Severodvinsk. The storage facility is fenced in and marked with danger signs warning against radiation. The facility consists of an underground concrete bunker subdivided in two sections of six rooms. Known as Object 379, the structure is 14.89 meters long and 5.2 meters high.

Radioactive waste was first stored at this location in 1964, and plans from the very outset called for the establishment of an incinerator-treatment plant to burn and then pack the waste for storage in a nearby facility. However, only the storage facility was ever built. The last time nuclear waste was delivered here was in 1976 at which point the storage facility was full. The facility was then sealed and covered with asphalt. The facility contains 1 840 m³ solid radioactive waste, but there is little information concerning the activity of the waste which is claimed to be of low to medium activity.⁴⁴⁷ On August 17, 1963, it was decided to close the temporary storage of solid radioactive waste at workshop no. 43 in Zvezdochka with all of waste already stored there to be

438 Presidential decree No. H-1344, November 8, 1992.

439 Government decree No. 514, July 24, 1992 and decree No. 644-47, August 31, 1992.

440 Handbook from the GRTsAS, presented to the Russian government in 1993.

441 If other sources are not indicated, the information is taken from the handbook *On implementation plan for handling of nuclear waste and spent fuel on Severodvinsk Territory*, Summer 1994.

442 Document from the local Gosatomnadzor (V. Dimitriev), Severodvinsk environmental committee (M. Mailov) and the control committee for objects subject to the Ministry of Defence (A. Gordienko) 1995.

443 *Severny Rabochy*, March 23, 1995.

444 Document from the local Gosatomnadzor (V. Dimitriev), Severodvinsk environmental committee (M. Mailov) and the control committee for objects subject to the Ministry of Defence (A. Gordienko), 1995.

445 Nilsen, T., and Bøhmer, N., Sources of Radioactive Contamination in Murmansk and Arkhangelsk Counties. Bellona Report no.1 :1994.

446 The information in this paragraph is taken from a document issued by the local Gosatomnadzor (V. Dimitriev), Severodvinsk environmental committee (M. Mailov) and the control committee for objects subject to the Ministry of Defence (A. Gordienko), 1995.

447 Nilsen, T., and Bøhmer, N., Sources of Radioactive Contamination in Murmansk and Arkhangelsk Counties. Bellona Report no.1 :1994.



The naval yards in the closed city Severodvinsk west of Arkhangelsk carry out maintenance operations on active nuclear submarines as well as decommissioning procedures on older nuclear submarines. Severodvinsk is also the only place in Russia where new nuclear submarines continue to be built.

transferred to the Mironova site. Information about the contents of this waste is lacking; hence it is impossible to give an account about the total radioactive content of this storage site.⁴⁴⁸

It is the Health Physics Department at Sevmash which monitors radiation levels at Mironova Heights, and levels of 5-6 microSv/h (500-600 microR/h) have been detected immediately above the storage chambers. Outside the enclosed area there have been no reports of increased radiation levels. Rainwater around the storage site is checked periodically. Radiation above the background levels of 0.2 microSv/h (20 microR/h) have not been detected in the nearby rivers Solza, Rassoha and Shirshema. However there are some test samples indicating that the storage chambers are not absolutely tight. In 1991, a hatch above one of the storage sections was opened and the cavity allowed to fill with rainwater. The activity of this water was measured to $10^2 - 10^5$ Bq/l of ^{137}Cs and up to 10^2 Bq/l of ^{60}Co . Activity levels varied by a factor of up to 60 in the different rainwater drainage systems around the facility. There is no stationary dosimeter inspection which monitors the situation on a regular basis. A 1992 attempt to establish automatic surveillance of the water failed when the instruments broke down. Several attempts have been made to secure the storage site, but this has never been done to the satisfaction of control authorities.

The temporary storage facility for solid radioactive waste at Sevmash⁴⁴⁹

There is a temporary storage facility at the Sevmash

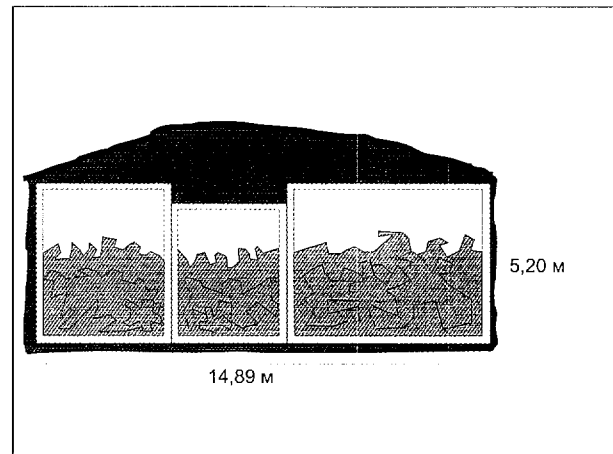

This drawing shows a cross-section of the storage facility for solid radioactive waste at Mironova Heights outside Severodvinsk. Numerous leaks of radioactivity have been detected from this facility.

yards for solid radioactive waste consisting of contaminated equipment from the testing of new submarine reactors. Until 1991, the site was used for the temporary storage of waste which would ultimately be dumped at sea. When this practice was terminated in 1991, the storage facility was rebuilt and improved. Official approval of the facility was granted on May 5, 1992.

The Northern Fleet is responsible for emptying this storage facility, but there has been no removal of waste from the facility over the past four years. According to facility regulations, waste can be stored for a maximum of six months before being sent elsewhere. Current practice is therefore in violation of the regulations set for the facility. In fact, the actual storage facility itself falls short of requirements set by the authorities in Severodvinsk. The facility consists of one closed compartment and an open area where large pieces of contaminated materials are stored. In 1993, 79 m^3 of waste were stored here; by 1995, this figure had increased to 216 m^3 . The total weight of the waste is estimated at 213.8 tons. Storage capacity in the closed section is estimated to be 239 m^3 , while the outdoor storage area should have room for a lot more. An overview of the waste stored at this facility is given in the table below:

Storage of solid radioactive waste at Zvezdochka⁴⁵⁰

At Zvezdochka, containers of solid radioactive waste are stored in a large partially buried concrete construction. Most of the waste consists of contaminated equipment and tools used in the repair of nuclear submarines.

448 Klimov, A., note, 1996.

449 The information in this paragraph is taken from a document issued by the local *Gosatombnadzor* (V. Dimitriev), Severodvinsk environmental committee (M. Mailov) and the control committee for objects subject to the Ministry of Defence (A. Gordienko), 1995.

450 Document from the local *Gosatombnadzor* (V. Dimitriev), Severodvinsk environmental committee (M. Mailov) and the control committee for objects subject to the Ministry of Defence (A. Gordienko), 1995.

Table 7: Overview of radioactive waste at Sevmash

No.	Type waste	Storage method	Number	Amount	Activity
1.	Pipes, tools, clothing, filters.	Containers	67	219 m ³	92 GBq (2.5 Ci)
2.	Large equipment	Containers or in the open	20	42 m ³	1.0 TBq (27.5 Ci)
Total:			87	216 m ³	1.1 TBq (30 Ci)

Table 8: Storage of solid radioactive waste at Zvezdochka

No.	Description	Storage method	Number	Amount	Activity
1.	Pipeline, equipment, clothing et. cetera.	Containers	271	880 m ³	
2.	Large equipment.	Compacted	120	202 m ³	
3.	Parcels of contaminated metals.	Unshielded		30	50 m ³
Total			421	1 132 m ³	5,4 TBq (147 Ci)

Table 9: Overview of the four Severodvinsk storage facilities for solid radioactive waste.

No.	Name	Responsible body	Amount	% of capacity	Condition
1.	Mironova-heights	Sevmash	1 840 m ³	100	Unsatisfactory
2.	Temporary storage	Sevmash	2 475 m ³	25	Usual condition
3.	Storage	Zvezdochka	1 530 m ³	85	Unsatisfactory
4.	Temporary storage	Zvezdochka	6 685 m ³	approaching 100%	Unsatisfactory
Total			12.520 m ³		

Built in 1963, the storage facility is situated close to the shoreline, and contains some highly active waste. In 1995 storage capacity was given as 1.530 m³ while in 1993, its capacity was 1 200 m³. This suggests that either the facility has been expanded or more waste is being stored here than was previously assumed.

The concrete structure is open in several places such that rainwater can enter, and as a result, there has been leakage of radioactive water from the facility. Eighty five percent of the storage capacity has now been used, and heretofore, there is no comprehensive description of the waste that is stored here. What is known is that the facility contains some large contaminated reactor components with an activity of 11 TBq (300 Ci), repair equipment (activity of 15.9 TBq (430 Ci)), filters (activity of 5.6 TBq (150 Ci)), pipes and protective gear (activity of 5.4 TBq (20 Ci)) and gamma sources used in quality control of metals (activity of 10.8 TBq (40 Ci)). Some of the waste is stored in containers that are

spread haphazardly all over the storage facility. The containers are of a type used when radioactive waste was routinely dumped at sea; hence they are perforated so as to permit sea water to enter in and cause them to sink. Subsequently, the contents of the containers stored in the solid waste facility at Zvezdochka are not well sealed, and there are leaks of radioactivity from the facility. In response to the lack of order and control over leakage, in 1993 *Gosatombadzor* prohibited any further deposits of waste at the facility. Comprehensive technical studies will be required and the facility probably rebuilt before it can be taken into use again.

Temporary storage of solid radioactive waste at Zvezdochka⁴⁵¹

Outside the concrete bunker there is a temporary storage site for solid radioactive waste. The area was taken into use in 1983. Low to medium level waste is stored here,

451 Ibid.

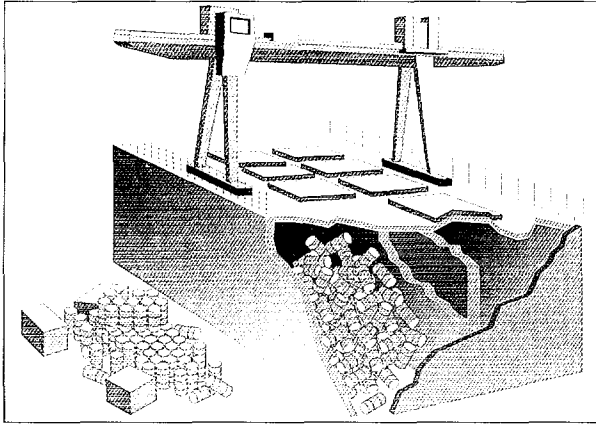

A drawing of the storage facility for solid radioactive waste at *Zvezdochka* shipyard. Waste is stored both in containers and in open air. There are also a number of containers and larger contaminated parts standing outside of the facility with no protective cover or shielding.

some of it in containers. It consists largely of contaminated equipment. The storage facility covers an area of 135 by 30 meters and is partially covered by asphalt. The area is surrounded by a drainage system to collect rainwater which may have been contaminated. (Much of the contaminated equipment is completely unshielded). As of May 1, 1994, there was a total of 1 132 m³ of solid radioactive waste stored here, as specified in the table below.

Numerous regulations have been violated at this facility. Among the most serious concerns are the facts that the facility is unprotected, it is located less than 500 meters from the shore, there is no monitoring of the ground water below the site, and the regulations governing the length of time that the waste may be stored (maximum 6 months) have been breached. Consequently, the facility must either be rebuilt or closed.

In addition to the four storage sites mentioned above, solid radioactive waste is also stored in the floating workshops and on board service ships. The total amount of solid radioactive waste stored in Severodvinsk comes to more than 12 530 m³. The table below gives an overview of the total amounts of solid radioactive waste stored at the four Severodvinsk sites.

5.6.2 Treatment of liquid radioactive waste⁴⁵²

On an annual basis, the naval yards at Severodvinsk produce between 2 200 and 3 100 m³ of liquid radioactive waste. Only small amounts originate from the Sev-mash yard, the greatest part coming from *Zvezdochka* where the repairs and servicing procedures on submarine reactors require large quantities of water. Until 1991, much of this waste was transported away on ser-

vice ships and dumped in the Barents sea. In the 1960s, decontamination plants were established at both yards. However, these were never taken into use and are now partially disassembled.

Today, approximately 3 000 m³ of liquid radioactive waste is stored in Severodvinsk. In addition to the storage facilities and ships listed below, Severodvinsk also has a permanently stationed special service tanker of the Project 1783 - Vala class, with a storage capacity of 870 m³. Some of the floating bases used to store spent nuclear fuel assemblies also carry some liquid radioactive waste and are described in Chapter 3. The liquid radioactive waste generated in Severodvinsk was until 1973 regularly collected by Northern Fleet service ships.

Storage of liquid radioactive waste in sea-based tanks at Sev-mash

The Sev-mash yards have five sea-based tanks for storing liquid radioactive waste. Three of the tanks have been taken out of use as they were worn out. Since the metal itself is contaminated, these tanks must now also be treated as nuclear waste. At the present time, no solution for the scrapping and storage of these tanks has been found. The two tanks which remain in use each have a capacity of 24.8 m³ of liquid radioactive waste. The contaminated water in the tanks is periodically transferred to the liquid waste facility at *Zvezdochka*.

Object 159 at *Zvezdochka*

Three land based tanks have been established to collect liquid waste from different areas of the yard (called "Object 159"). Object 159 consists of two type A-02 tanks, each with a capacity of 500 m³. The third tank is a type A-04/2 relief tank with a capacity of 100 m³. One of the A-02 type tanks was overhauled in May 1994, having been disused for a while. The other type A-02 tank which was first taken into use in 1965, is not in use and cannot be utilised until comprehensive improvements have been made. This is because widespread corrosion throughout the tank has damaged the metal. The two tanks which are in use contain a total of 181 m³ liquid radioactive waste with an activity of 8.3 GBq (0.225 Ci).

The special tanker *Osetiya*

The tanker *Osetiya* is specially constructed for the temporary storage and transport of liquid radioactive waste. The ship was first taken into use in 1963. She has nine tanks with a total capacity of 1 033 m³ liquid radioactive waste. The ship was overhauled in 1990 but is still not permitted outside the harbour area. Today it is regis-

⁴⁵² Ibid.

tered as being stationary. At the moment there are 563 m³ of liquid radioactive waste stored on board with an activity of 83.3 GBq (2.25 Ci).⁴⁵³

5.6.3 Release of radioactive gases from Zvezdochka⁴⁵⁴

Every year, about 10 000 m³ of radioactive gases are released from the Zvezdochka yard. The gases are released during the repair of naval reactors or in defuelling operations. Some emissions also stem from the laboratories and storage facilities. The predominant gases are krypton-85 and xenon-133. Gas from the laboratories and construction halls is collected in balloons where the activity level is measured. Before the gas is released, it is passed through a number of special filters. If activity is higher than permitted, the gas is diluted with air prior to being released. There is no upper limit to the amount of radioactivity which can be released over the course of a year. The gases from the incinerator for solid radioactive waste are also monitored and filtered. When radiation levels surpass a pre-set limit, the incinerator stops. This happens quite frequently as the filters are relatively inefficient. During the first half of the 1990s, the incinerator was only in operation for one month per year on average.⁴⁵⁵

5.6.4 Storage of reactor compartments and spent nuclear fuel

There are now 16 nuclear submarines in Severodvinsk still containing their fuel. Twelve of them are laid up and scheduled to be dismantled. The other four are

waiting to be repaired or refuelled. There are also four reactor compartments from submarines that have already been dismantled. These come from the submarines K-228, factory no. 470, and K-444, factory no. 461 (both Project 667 A - Yankee class vessels), and from K-316, factory no. 905, and K-432, factory no. 106 (both Project 705 - Alfa class). In 1994 four submarine hulls still containing their reactor compartments were towed to the Sayda Bay.

The missile compartments from the 12 laid up submarines have been cut out and the fore and aft hull sections then welded back together. This procedure has left a large crack between the two hull parts (see picture), thus increasing the danger of corrosion and impairing the ability of the submarine to float. In order to ensure buoyancy, pressurised air is pumped into the hulls.⁴⁵⁶ However, as long as the nuclear fuel remains on board in the reactor compartments, these submarines constitute a safety risk. (See Chapter 6 on the decommissioning of submarines.)

One reactor compartment is stored on land in Severodvinsk. It comes from the Project 705 - Alfa class submarine K-47, factory no. 900. The reactor still contains its nuclear fuel and has been stationary at Severodvinsk since the 1970s. The submarine cannot be defuelled, for the fuel assemblies are stuck in the reactor's liquid metal coolant which has solidified. According to plans, this reactor will be transported to Sayda Bay.⁴⁵⁷

There is no land based storage facility for spent nuclear fuel in Severodvinsk. Spent fuel is stored aboard the service ships PM-63 and PM-124. These vessels have a capacity of four and two reactor cores, respectively.⁴⁵⁸

453 Severny Rabochy, February 23. 1995.

454 Nilsen, T., and Bøhmer, N., Sources of Radioactive Contamination in Murmansk and Arkhangelsk Counties. Bellona Report no.1 :1994.

455 Ibid.

456 *Sinking Radioactive Nightmare*, SVT2 - Norra Magasinet.

457 Information given at a nuclear safety meeting, Severodvinsk, 7 March 1995.

458 Information given at a Severodvinsk press conference in connection with removal of spent fuel elements from submarine factory No. 401, March 1995.

Decommissioning of nuclear submarines

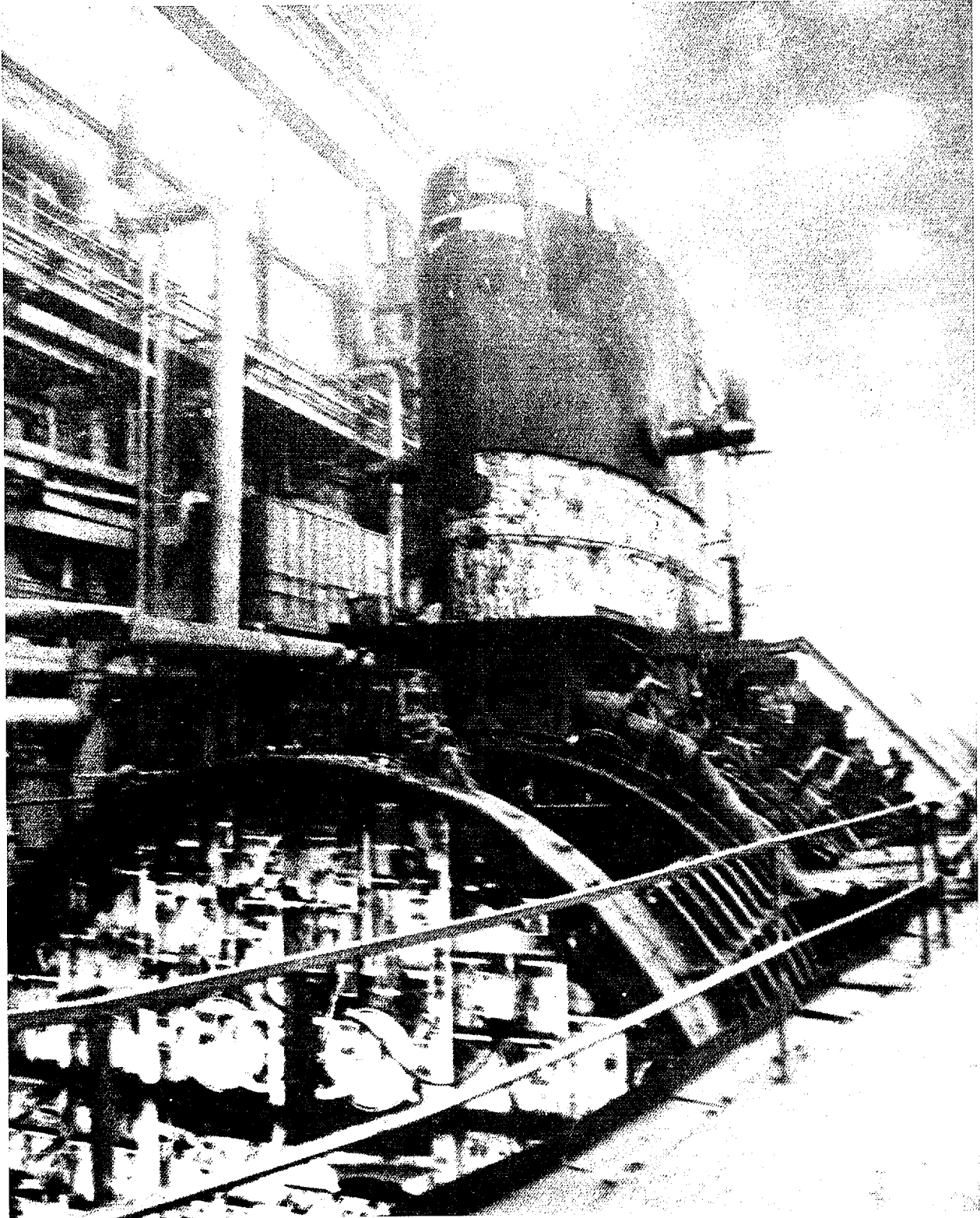

Decommissioning of nuclear submarines

At this time, just over 130 nuclear powered submarines have been taken out of service and are laid up. Eighty-eight of them belong to the Northern Fleet; fifty-two still carry nuclear fuel in the reactors.⁴⁵⁹ Fifteen reactor compartments have been removed from the hulls and have been prepared for storage. In all probability, around 150 nuclear submarines will be taken out of service with the Russian Navy by the year 2003.⁴⁶⁰ Inactive Northern Fleet submarines are laid up at Gremikha, Severodvinsk, Vidyaevo (Olenya Bay, Sayda Bay and the Nerpa yards), Polyarny (Shkval), Sevmorput, Gadzhievo (Ara and Ura Bays) and Zapadnaya Litsa.⁴⁶¹ The dismantling of first and second generation submarines has commenced, whilst the dismantling of third generation vessels is still in the planning stage.⁴⁶²

6.1 Laid up nuclear submarines

Since the middle of the 1980s, nuclear powered submarines have been taken out of service and prepared for decommissioning.⁴⁶³ The first generation nuclear submarines that were taken out of service early in the 1980s and laid up is now being prepared for dismantling. Until now Russia has not decommissioned a single submarine where the problems of handling and storage of reactor compartments have been solved in a satisfactory manner. The decommissioning of nuclear submarines has become a Russian national problem. There is a great shortage of qualified technical facilities coupled with a lack of sufficient funding to carry out the work. As increasing numbers of submarines are retired from active service, the lack of suitable storage for spent nuclear fuel and other nuclear waste will present a significant problem. Storage facilities are already filled to capacity.

Russian nuclear submarines are decommissioned for three reasons. Firstly, some of the vessels are more than 25 years old and past their effective operational life. Some of them have undergone serious accidents and are beyond repair. Secondly, the greatly reduced Russian defence budget precludes maintenance and upgrading of the large cold war force of nuclear submarines established by the Soviet Union. Thirdly, international disarmament treaties for the reduction of naval nuclear strategic warheads require a reduction in the number of submarines.⁴⁶⁴

Until the middle of the 1980s, older nuclear submarines were kept in service as long as possible. Most of these vessels were very run down and some of them spent up to ten years in ship repair yards. Large sums were spent on the maintenance of this large but ageing fleet. The only submarines that were taken out of service were those whose fuel assemblies had been so badly damaged that refuelling was impossible.⁴⁶⁵ These vessels were either laid up or dumped in the Kara sea.

Until 1986, there were no formal plans for the decommissioning of obsolete nuclear submarines.⁴⁶⁶ In 1986, the Central Committee of the Communist party and the Supreme Soviet ratified Decree No. 095-296 which laid down formal procedures for decommissioning and dismantling inactive nuclear submarines. The decree contained the following main points:

- Weapons and other important equipment to be removed. Vessels to be laid up with reduced crew in suitable locations at Navy yards.
- Fuel elements to be removed from the reactor.
- Decommissioning of vessel by cutting out the reactor compartment. Non-contaminated metal to be reused.
- Sealing and transporting the reactor compartments to suitable locations for long term storage. Storage to be undertaken where radiation safety is maintained and can be verified.

In connection with this, a special decree regarding

459 *Komsomolskaya Pravda*, June 23, 1995.

460 *Krasnaya Zvezda*, July 13, 1995.

461 Kvaerner Moss Technology as., *Disposal of Russian Nuclear Submarines*, January 19, 1996.

462 *Problems of Decommissioning of Nuclear Powered Submarines and Environmental Protection in the Northern areas*, Severodvinsk March 15 - 16, 1995.

463 *Morskoy sbornik* No. 4 - 1992.

464 *Morskoy sbornik* No. 7 - 1992.

465 *Morskoy sbornik* No. 4 - 1992.

466 *Decommissioning obsolete submarines and storing reactor compartments*. Paper presented at conference on Problems in Decommissioning and Dismantling of Nuclear Submarines, Moscow, June 19-22, 1995.

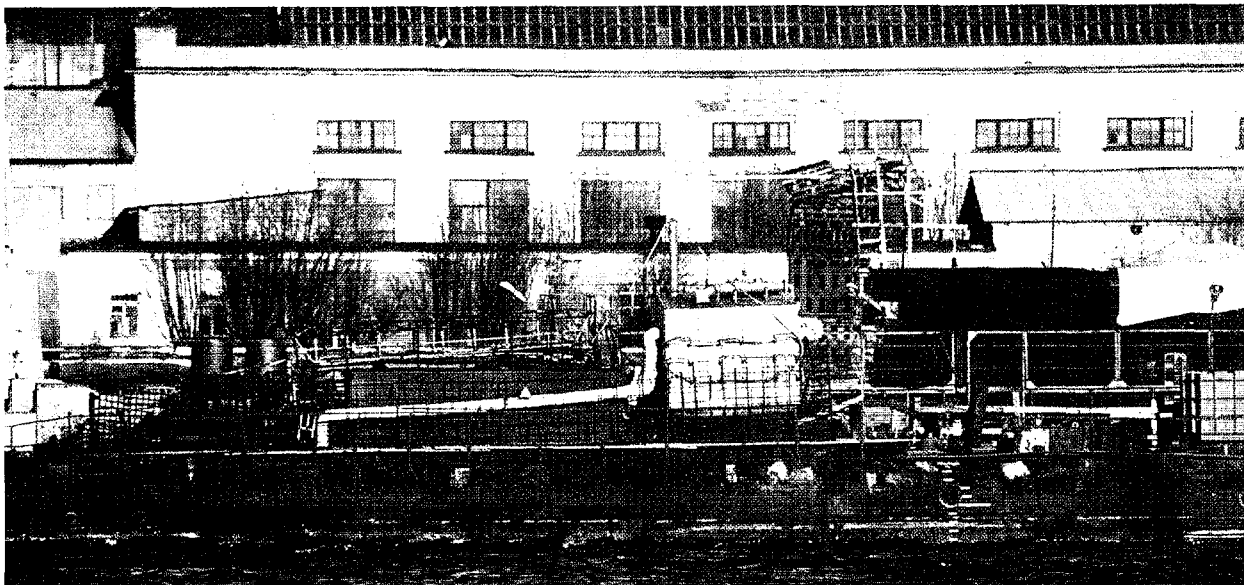

This Hotel class nuclear submarine is moored at the Sevmorput shipyard in Murmansk. Work on decommissioning the vessel had begun, but the spent fuel assemblies had not yet been removed from the reactor at the time that this photograph was taken. Above the reactor compartment may be seen a metallic coloured hut containing the equipment that is used for removing fuel assemblies from the reactor compartment. There are signs all around the quay where the submarine is moored warning of radiation danger, an indication that radiation from the reactor compartment can be measured outside the hull of the submarine.

safety routines for laid up nuclear submarines was ratified in early 1988.⁴⁶⁷ It was not until 1991, under the precepts of Resolution No. 714/13/0105, that the Russian Navy adjusted its guidelines for delivering inactive submarines for dismantling.⁴⁶⁸

The first resolution regarding the order in which the submarines were to be delivered for dismantling came in July 1992 when the Russian government ratified Decree no. 514. According to this, a number of submarines scheduled for dismantling and metal recycling were to be transferred from Navy jurisdiction to shipyards subject to the Ministry of Industry. In this way, commercial enterprises gained access to decommissioning work. Specifically, three Project 705 - Alfa class nuclear submarines with liquid metal cooled reactors (factory nos. 905, 910 and 106), four Project 667 A - Yankee class submarines (factory nos. 451, 462, 470 and 421), one Project 670 - Charlie class submarine (factory no. 903), and one Project 671 - Victor class (factory no. 615) vessel were listed.⁴⁶⁹

The shipyards received the proceeds from the sale of scrap metal as payment for their work in decommissioning the submarines.

The Russian Navy, represented by the Supreme Commander of the Northern Fleet, Admiral Oleg Yerofeev, has expressed great displeasure over this decree. He feels that the Navy should benefit from the sale of scrap metal since the submarines are the property of the Russian Navy.⁴⁷⁰



The reactor compartment from the Alfa class nuclear submarine K-47 has been in Severodvinsk since the 1970s. The fuel elements have been left inside the reactor because the metal coolant has solidified. There are plans to set the reactor afloat and tow it north to Gremikha on the Kola Peninsula for storage.

In August 1993, the Russian government ratified Decree no. 644-47 concerning the completion of dismantling operations on nuclear submarines. The decree particularly addresses plans for upgrading the Zvezdochka naval yard in Severodvinsk and the Nerpa Shipyard on the Kola Peninsula. The upgrading concerns largely the construction of new dry docks and equipment

467 *Morskoy sbornik*, No. 4 and 6 - 1993.

468 Russian Navy ratification, May 4, 1991.

469 Governmental decree No. 514, July 24, 1992.

470 *Nezavisimaya Gazeta*, April 22, 1995.

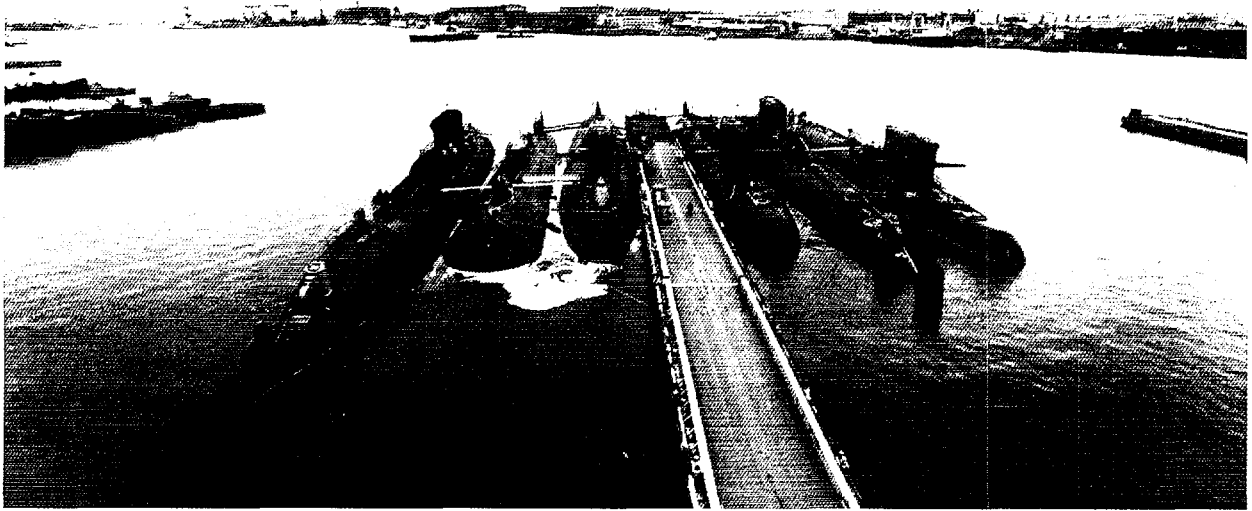

These six nuclear submarines (five Yankee class and one Charlie class) are laid up at a pier at the naval base Belomorskaya in Severodvinsk awaiting decommissioning. Many of the submarines that are presently laid up are in very poor technical condition. Compressors for pressurised air are mounted in all six of the vessels pictured here. Pressurised air is pumped into the hull to prevent the submarines from sinking at the quay. There are clear signs of air bubbles in the water around the Yankee class submarine moored closest to the pier on the left side, a strong indication that the vessel's hull is not airtight. On the other side of the channel, to the far right of the photograph, the apartment blocks of Severodvinsk may be seen, a town with 210 000 inhabitants.

for removal, transport and storage of spent nuclear fuel. It also encourages comprehensive research into the responsible decommissioning of nuclear submarines.⁴⁷¹ On May 1, 1994, Decree no. 548 outlining guidelines for the "federal programme for industrial decommissioning of weapons and equipment" was ratified.

The problems associated with the decommissioning of nuclear submarines were raised in the Duma on June 14, 1994, at the Commission for Emergency Action on March 14, 1995 and at two international conferences held in Severodvinsk on March 23, 1994, and in Moscow on June 19-20, 1995.

Despite the various decrees and discussion on the decommissioning of nuclear submarines, the actual work is far behind schedule. So far, no submarine has been decommissioned in a responsible manner in compliance with the regulations. Some submarines have been completely dismantled, but their reactor compartments have either been dumped in the Kara Sea or are still stored floating on the sea. According to naval yard authorities, safe decommissioning of nuclear submarines will not be possible for another five to seven years.⁴⁷² The Russian Ministry of Defence claims that

the present economic situation rules out a sustainable rate of decommissioning before 2005-2010.⁴⁷³ This is because of the time that is required to develop the necessary infrastructure. Many essential facilities are lacking, including proper equipment for defuelling the reactors, facilities for dismantling the vessels and above all, facilities for the treatment and storage of radioactive waste and reactor compartments.⁴⁷⁴

A new decommissioning dock for the Northern Fleet is under construction in Kherson, Ukraine, but delivery has been postponed by non-payment of the 8 million USD bill.⁴⁷⁵ The safety of the mooring areas for decommissioned submarines today is considered unsatisfactory. The Northern Fleet Supreme Commander, Admiral Oleg Yerofeev, has stated that the level of safety at these sites is steadily deteriorating, and that there is a real danger of radioactivity being released from laid up submarines because they can sink. He considers the lack of suitable storage facilities for the reactor compartments to be the greatest problem.⁴⁷⁶

Of the 88 nuclear submarines that have been taken out of service, the location is known for 70. These are shown in the table below.⁴⁷⁷

471 Steblin, P. G., director of the Nerpa yard, presented in the document: *Difficulties of decommissioning of submarines and protection of the northern environment*, Severodvinsk, March 15 - 16, 1995.

472 *Krasnaya Zvezda*, July 13, 1995.

473 *Murmansky Vestnik*, March 15, 1995.

474 *Severny Rabochy*, March 23, 1995.

475 *Jane's Navy International*, November-December 1995.

476 *Nezavisimaya Gazeta*, April 22, 1995.

477 Summary based on information given in Chapters. 2, 4 and 5 compared with information from *Disposal of Russian Nuclear Submarines*, Kværner Moss Technology, January 19 1996.

Table 10. Summary of locations of laid up nuclear submarines, including number of defuelled vessels.⁴⁷⁹ The summary states the number of submarines with and without fuel, respectively (w/o).

Z. Litsa	Ara	Ura	Sayda	Olenya	Shkval	Sevmorput		Gremikha	Severodvinsk
With/out	w/o	w/o	w/o	w/o	w/o	w/o	w/o	w/o	
Project 627 A									
November				0/1		3/0		4/0	
Project 658									
Hotel				0/2	1/0	1/0	1/0	1/0	
Project 659									
Echo-II		5/0	6/0	0/2	1/0	1/0			
Project 661									
Papa									1/0
Project 667 A									
Yankee				1/2					10/5
Project 667 B									
Delta						1/0			
Project 670									
Charlie-II		1/0	1/0		0/1				
Project 671									
Victor					0/1	3/0		8/0	
Project 705									
Alfa	1/1			0/1					1/2
Total	1/1	6/0	7/0	1/8	3/2	8/0	1/0	13/0	12/7

6.2 Safe storage of nuclear submarines

The steadily worsening technical condition of the laid up nuclear submarines has led to a number of temporary safety measures. These include attempts to keep the vessels afloat by the constant pumping of compressed air into the hulls, welding of bottom seacocks and periodic docking. In order to prevent leaks of radioactivity from the reactor core, the reactors are treated with self-sealing solutions.⁴⁷⁸

These measures minimise the risk of spontaneous chain reactions in the nuclear fuel through accidental contact with sea water. Nevertheless, there is a significant risk of leaks of radioactivity should the submarine sink. The reactors of vessels that have not been defuelled must be cooled periodically by circulating coolant through the primary circuit. This is achieved by supplying electrical current from a land-based source or from the vessel's own diesel generators or batteries. If all of these power sources should fail in the wintertime, there is a risk of the coolant freezing in the primary circuit and thus damaging the fuel assemblies, making them difficult to remove at a later date.

The safety measures that have been applied hardly include monitoring the condition of the nuclear fuel in the reactor. Hence it cannot be discounted that accidents or leaks of radioactivity could occur in future defuelling operations. The reactors themselves are in markedly worse condition than those on operational vessels, for there is more humidity and variations in temperature as well as the risk of sea water entering the hull. Compressed air is pumped into the hulls to prevent them from sinking. Corrosion is another problem for laid up submarines.⁴⁸⁰ Steps have been taken to prevent sea water from entering reactor compartments, and pipes and cable ports are sealed with a special putty.⁴⁸¹

Laid up nuclear submarines have only one third of the crew used on operational submarines, that is, less than 40 men. Overall, the Northern Fleet has about 2 000 people stationed on the laid up submarines, operating on shifts. The crew members often lack the necessary training or are assigned to a laid up submarine either because they are lacking in competence or are unfit to serve on an active vessel. Thus the lack of competent, qualified personnel increases the possibility of emergency procedures not being executed correctly in the event of a serious incident.⁴⁸²

478 *Morskoy sbornik*, no. 7 - 1992.

479 *ibid.*

480 *Murmansky Vestnik*, January 11, 1995.

481 *Difficulties in decommissioning of submarines and protection of the northern environment*, Severodvinsk, March 15-16 1995.

482 *Murmansky Vestnik*, January 11, 1995.



Work is underway to remove spent fuel assemblies from the reactor of a Charlie class submarine at the *Zvezdochka* shipyard. The costs of dismantling the submarine are paid by the shipyards themselves against the shipyard retaining the proceeds from the sale of the scrap metal. The only exceptions are the work to cut out the reactor compartment and the handling of the radioactive waste. These are operations paid for by the Russian state.

The work of removing spent nuclear fuel from laid up submarines is proceeding very slowly. This is partly because of a lack of proper equipment, and partly by limitations of transport and storage facilities. Since the early 1990s, the Northern Fleet has been responsible for funding the forwarding of spent nuclear fuel to the reprocessing plant RT-1 in Mayak.⁴⁸³ Hence the Northern Fleet prioritises the refuelling of operational submarines over the defuelling and decommissioning of inactive vessels. In the entire period between 1988-1995, only ten Northern Fleet submarines have been defuelled.

6.3 Dismantling of submarines

The Russian Navy bears the chief responsibility for the dismantling of its nuclear submarines. The Navy has ownership and is also responsible for safety. This is true despite the fact that a number of documents and decrees charge the State Committee for Defence Industries, Minatom and the Ministry of Finance with the responsibility of handling of spent fuel and radioactive waste from decommissioned submarines. The Navy's primary responsibility is to ensure the safe transport and temporary storage of reactor compartments and nuclear waste.⁴⁸⁴

There are several reasons for the unresolved problems of areas of responsibility and that decommissioning is proceeding so slowly. Firstly, the Navy does not wish to relinquish control of its submarines without being paid for them. Secondly, the yards that have been charged with the work of dismantling lack the necessary equipment. There is a severe shortage of storage for the large amounts of radioactive waste that the work will generate, and suitable transport containers are in short supply.⁴⁸⁵ All of this results both in a longer lead time before the inactive submarine is finally processed at the shipyard and a further accumulation and backlog of laid up submarines.

6.3.1 Economic aspects

The work of scrapping the nuclear submarines is financed by the Navy yards against receiving a partial refund on the revenue from the sale of scrap metal. However this does not apply to the removal of missile and reactor compartments which is financed by the state. Navy yards are permitted to co-operate with commercial institutions and foreign enterprises. They are also given the opportunity to sell the scrap metal on the international market. Until March 1995, tax exemptions were granted for Navy yards selling metals from dismantled submarines.⁴⁸⁶

Official documents and decrees assume that decommissioning nuclear submarines is self-financing, that is, that the participants in the decommissioning work will make a profit on the sale of the salvaged metals. However, Navy yards that decommission submarines operate at a large loss. For example, the decommissioning of the Project 667 A - Yankee class K-241, factory no. 462 in 1993 resulted in a loss of 311 million roubles (1993) for the *Zvezdochka* yard.⁴⁸⁷ Sixty tons of copper, 100 tons of lead and 20 tons of aluminium were salvaged from this submarine and sold.

The dismantling of a Project 667 A - Yankee class submarine generates 3 300 tons of scrap metal, of which there are 300 tons of stainless steel, 1 100 tons of low magnetic steel, 1 900 tons of ordinary steel, 50 tons of copper, 70 tons of brass, 70 tons of bronze, 30 tons of cuprous nickel, and 5 tons of aluminium.⁴⁸⁸ The corresponding figures for a project 667 B - Delta-I class submarine are a total of 2 096 tons broken down into 554 tons of stainless steel, 220 tons of non-ferrous metals, 90 tons of titanium alloy, 95 tons of copper wiring and 58 tons of lead.⁴⁸⁹

483 Böhmer, N., and Nilsen, T., *Reprocessing Plants in Siberia*, Bellona working paper no. 4 - 1995.

484 *Nezavisimaya Gazeta*, April 22, 1995.

485 *Decommissioning obsolete submarines and storing reactor compartments*. Paper presented at conference on Problems in decommissioning and dismantling of nuclear submarines, Moscow, June 19-22, 1995.

486 Shukharov, F. N., vice president of the nuclear submarine construction centre Severodvinsk, presented in the document: *Problems of decommissioning of nuclear powered submarines and environmental protection in Northern areas*, Severodvinsk March 15 - 16, 1995.

487 *Ibid.*

488 *Severny Rabochy*, March 23, 1995.

489 Kvaerner Moss Technology as., *Disposal of Russian nuclear submarines*, January 19, 1996.

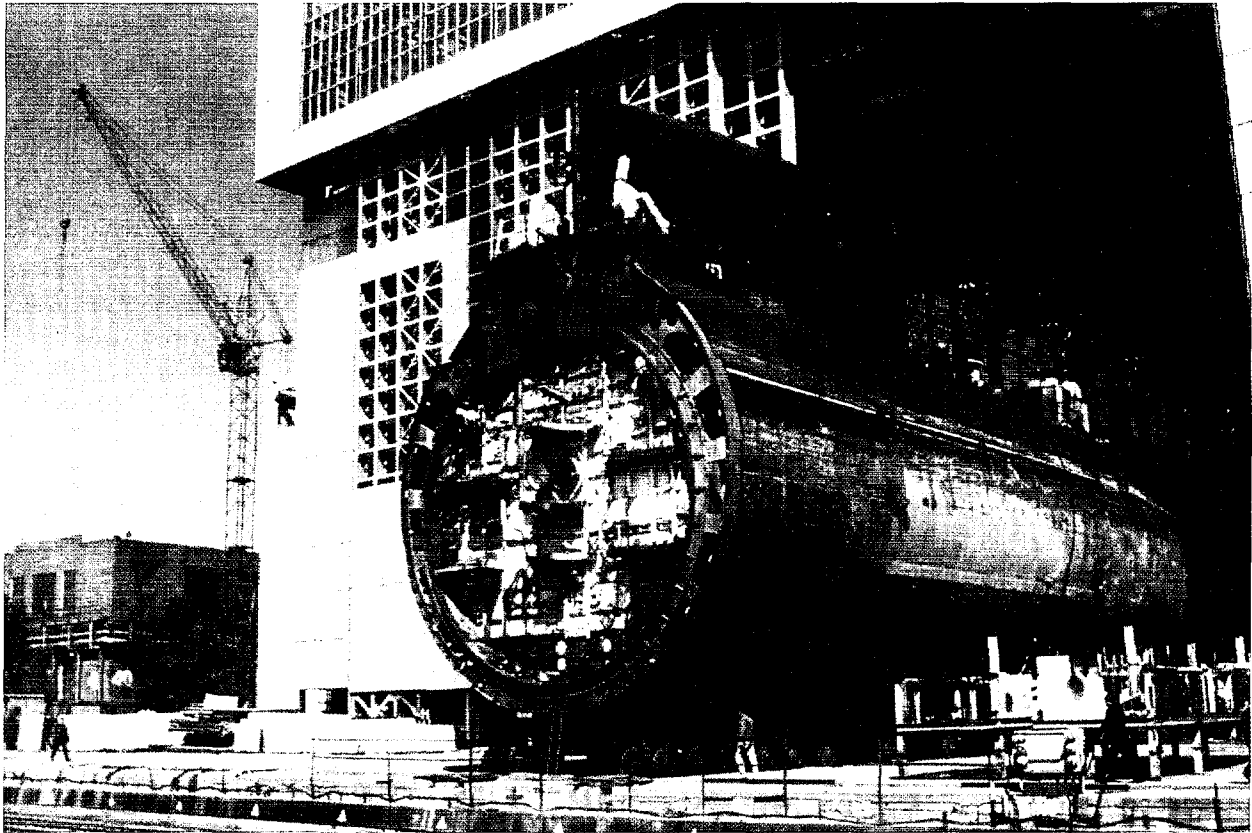

The naval yards in the closed city Severodvinsk west of Arkhangelsk carry out maintenance operations on active nuclear submarines as well as decommissioning procedures on older nuclear submarines. Severodvinsk is also the only place in Russia where new nuclear submarines continue to be built.

The Sevmash yards in Severodvinsk, charged with the task of dismantling the titanium-hulled submarines operate at an even greater loss per unit than Zvezdochka. The shipyard management estimate a loss of one billion roubles for the decommissioning of the Project 705 - Alfa class submarine K-463 (factory no. 915). Sevmash receives no tax relief on its foreign sales of metals. For the moment, the export tax on titanium alloys is set at 1 900 USD/ton, while the world market price is 1 000 USD/ton.⁴⁹⁰

With the current Russian industrial structure, real revenue from the sale of scrap metal can only be generated through export. Probably only the non-ferrous metals will be of interest to foreign buyers owing to the difficulty of smelting the tempered steel hulls. Until now, only Greece, Finland and China have bought ferrous scrap metal.⁴⁹¹ When dismantling nuclear submarines, special handling is required for large amounts of poisonous materials that have been used in the submarine. A submarine of the Project 667 B - Delta-I class is reported to contain 830 tons of noxious waste, of which 22 tons are battery acid.⁴⁹² No economic guarantees

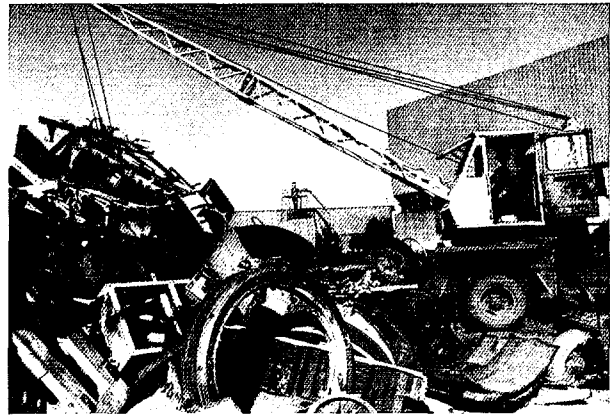

This scrap metal comes from a nuclear submarine that was dismantled in Severodvinsk. One Yankee class nuclear submarine generates 3 300 tons of scrap metal.

have been given by the state for the responsible handling of this waste.

There are much higher costs in dismantling the relatively few titanium-hulled vessels than in dismantling submarines with hulls made of tempered steel. This is

490 Shukharov, F. N., vice president of the nuclear submarine construction centre at Severodvinsk, presented in the document: *Problems of decommissioning of nuclear powered submarines and environmental protection in Northern areas*, Severodvinsk, March 15 - 16, 1995.

491 *Severnny Rabochy*, February 15, 1995.

492 Kværner Moss Technology as., *Disposal of Russian nuclear submarines*, January 19, 1996.

because a titanium hull requires more time to dismantle and more advanced equipment.⁴⁹³ Furthermore, it would appear that the Russian defence industry prefers to keep the metal itself.

The indications are that it will prove impossible to finance the decommissioning of nuclear submarines through the sale of scrap metals. Consequently either the Russian state or other agencies must be prepared to render large scale economic assistance to this work.

6.4 Parties to the work of dismantling submarines

Many differing parties are involved in the decommissioning process. This is true both for the theoretical side of the work as well as the more practical aspects of it. Participants include the former design bureaus, which have been involved in the development of nuclear submarines, the different northern naval yards and a whole range of official and semi-private institutions. New concerns have also been created by the State Committee for Defence Industries.

Theoretical planning has been put forth by the central design bureaus such as Rubin Central Design Bureau in St. Petersburg, Lazurit in Nizhny Novgorod and NIIPTB Onega which is the main institution for submarine repair. War Dept. No. 54034 in St. Petersburg, VNIPIET, bears the responsibility for naval construction and the Krilov Central Scientific Research Institute is the main institute for building naval vessels. CDB-Design Bureau is responsible for the development of reactor technology for Russian nuclear submarines while Test Design Bureau for Machine Building (OKBM) in Nizhny Novgorod has developed the plans for long term storage of reactor compartments in the northern regions.⁴⁹⁴

The St. Petersburg based Eko-Bio corporation has issued comprehensive plans for decommissioning nuclear submarines at a planned cost of 4 billion USD. Funding would be secured from western financial institutions and revenue generated by metal sales. The plans cover all phases of decommissioning up to and including storage of the radioactive waste. The Eko-Bio plans stand little chance of being put into practice.⁴⁹⁵ Plans for industrial co-operation in decommissioning of nuclear submarines have been established between

Energiya and the Norwegian company Kvaerner Moss Technology as. These plans are also purely on paper and stand little chance of attracting the necessary financing.

For the practical work the Ekon corporation is an important player. Ekon is based in Severodvinsk and was established on October 22, 1992 with a number of smaller concerns as stockholders: Zvezdochka shipyard (Severodvinsk), Remkon (Moscow), Sudprom (Moscow) and *Severnaya korabelnaya kompaniya* (Murmansk). Though these companies are not state run, they are under the leadership of men who belonged to the highest strata of the Russian Navy. Up until now, Ekon has been responsible for the decommissioning of three nuclear submarines at Severodvinsk.

The actual dismantling of Russian nuclear submarines is carried out at the Severodvinsk shipyards Zvezdochka and Sevmash, and at the Kola based yard of Nerpa. Some of the work is also parcelled out to naval yards No. 10 Shkval and No. 35 Sevmorput. Each yard has different tasks in the process of dismantling the different submarine classes.

The Zvezdochka yard is working on dismantling the Project 667 A - Yankee-class as well as some first generation Project 675 - Echo-II class submarines. In all, Zvezdochka has scrapped five submarines. These submarines were designed by Rubin Central Design Bureau and it is thus this body that has been assigned the task of co-ordinating their dismantling. In 1995, a total of 70 nuclear submarines were decommissioned (38 in the Northern Fleet and 32 in the Pacific Fleet) that had been designed and developed by the Rubin Central Design Bureau.⁴⁹⁶

Dismantling a Yankee class submarine takes 630 000 man hours. This includes a complete cutting up of the hull and preparing the reactor compartment for transport. The cost in 1995 terms was 22 billion roubles. The capacity at Zvezdochka is for four to five submarines per year on the precondition that the existing equipment for removal and transport of the nuclear fuel is functioning properly.⁴⁹⁷

There are plans to increase the capacity of Zvezdochka and the Kola Peninsula based Nerpa yard. Decree no. 644-47 of August 31, 1993, concerns this proposed expansion as well as the building of more dock facilities and increasing the storage capacity for spent nuclear fuel. Russia is currently negotiating with the United States on co-operative projects to increase dismantling capacity. American cutting tools have already been delivered to the Nerpa yards, including a

493 Ibid.

494 Shukharov, F. N., vice president of the nuclear submarine construction centre Severodvinsk, presented in the document: *Problems of decommissioning of nuclear powered submarines and environmental protection in Northern areas*, Severodvinsk, March 15 - 16, 1995.

495 Consultations with representatives of Eko-Bio, St. Petersburg, January 1995.

496 Goryledzyan, E. A., Rubin Institute, orally presented from pp. 26 - 27 in the document *Problems of decommissioning of nuclear powered submarines and environmental protection in Northern areas*, Severodvinsk, March 15 - 16, 1995.

497 Ibid.



The decommissioning of Russian nuclear submarines is largely carried out manually in that the workers, as for example this man at the *Nerpa* shipyard, cuts into the hull using a blowtorch. The vessel pictured here is a Victor-I class submarine. The decommissioning of a larger Delta-I class submarine is estimated to take 32 000 working hours.

plasma torch for *Nerpa* and several other tools to the Severodvinsk yards.⁴⁹⁸ From the point of view of the United States, it makes sense to deliver equipment which facilitates the removal of the submarines' missile compartments. The construction of a decommissioning facility at *Nerpa* began in 1993 and is scheduled to be completed in 1996. However, due to economic problems, the work has been delayed by a few years.⁴⁹⁹

The dismantling of titanium-hulled submarines takes place at the Sevmash yards in Severodvinsk. At present, work is ongoing to dismantle the Project 705 - Alfa class submarine K-316 (factory no. 105). The submarine K-463 has already been dismantled, and its reactor compartment taken to Sayda Bay.⁵⁰⁰ Two other submarines of this class are ready to be processed (factory nos. 905 and 106).⁵⁰¹ A titanium-hulled submarine of the Project 661 - Papa class is also moored in Severodvinsk waiting to be dismantled at Sevmash.

6.5 Stages in decommissioning

After transfer to the naval yard, the hull is cut into three parts. The submarine's missile compartment is then removed, in compliance with the terms of the disarmament agreements. This work is carried out in dry dock. Upon removal of the missile compartments, the remaining fore and aft parts of the submarine are welded back together. This is done in order to keep the submarine afloat while waiting for capacity for the removal of the nuclear fuel and securing of the reactor to become available. The submarines can be kept floating for several years in this manner while waiting for a dismantling slot to open.⁵⁰² The next step in the process is the removal of nuclear fuel from the reactor. This is described in Chapter 7.

498 Consultations with Yngvar Aagård, October-November 1995.

499 Steblin, P. G., director of the *Nerpa* yard presented in the document *Problems of decommissioning of nuclear powered submarines and environmental protection in Northern areas*, Severodvinsk, March 15 - 16, 1995.

500 Shukharov, F. N., vice president of the nuclear submarine construction centre Severodvinsk, presented in the document: *Problems of decommissioning of nuclear powered submarines and environmental protection in Northern areas*, Severodvinsk, March 15 - 16, 1995.

501 Governmental decree No. 514, July 24, 1992.

502 Sinking Radioactive Nightmare, STV - Norra Magasinet, 1994.

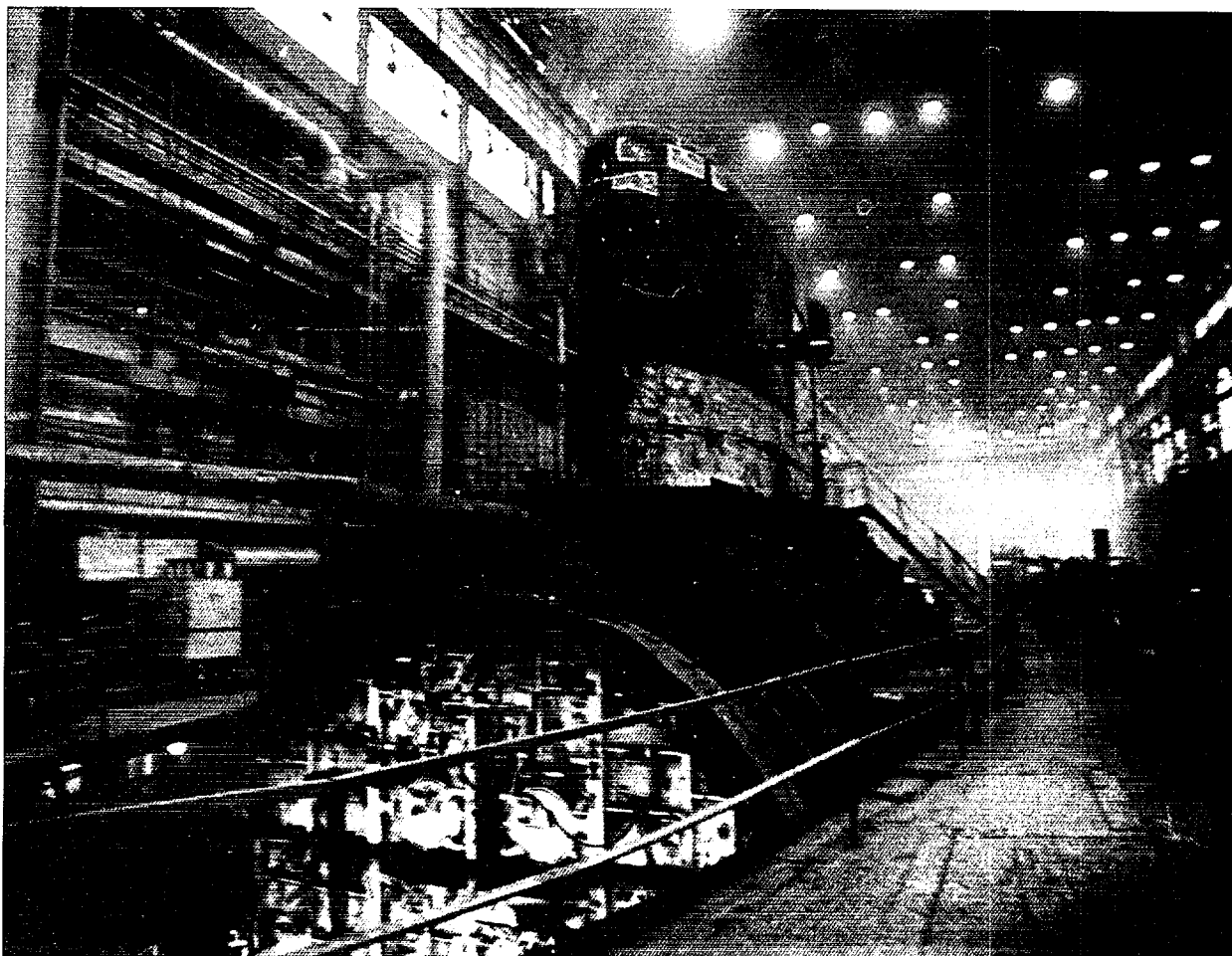

This Yankee class submarine is being opened up in one of the land-based dry docks at the *Zvezdochka* shipyard in Severodvinsk. The submarine must be in dry dock in order to remove both the missile section and the reactor compartment.

The terms of the START-II disarmament treaty require that the missile sections of the strategic nuclear submarines must be removed before the submarine can be considered among those that have been taken out of active service. This requirement has resulted in a situation where a number of the Yankee class submarines in Severodvinsk today remain afloat in two separate pieces. Here, the missile section has been removed and the vessel's forward and aft parts have been welded together again. The reactor compartment containing two reactors with their fuel assemblies remains inside the vessel's hull. As can be seen, sea water is penetrating through the crack between the two parts, thereby hastening the onset of corrosion and impairing the submarine's ability to float.

6.5.1 Preparation of the reactor compartments

The nuclear submarine is brought into dry dock and the process of cutting out the reactor compartment proceeds. It is estimated that the procedure of decommissioning of a Project 667 B - Delta-I class submarine will take 32 000 man hours.⁵⁰³ There are dry docks for this kind of work at the Severodvinsk and Nerpa yards, and there are plans to build a similar dock at naval yard no. 10 Shkval.

Preparing the reactor compartments for transport and long term storage can be accomplished in three different ways:

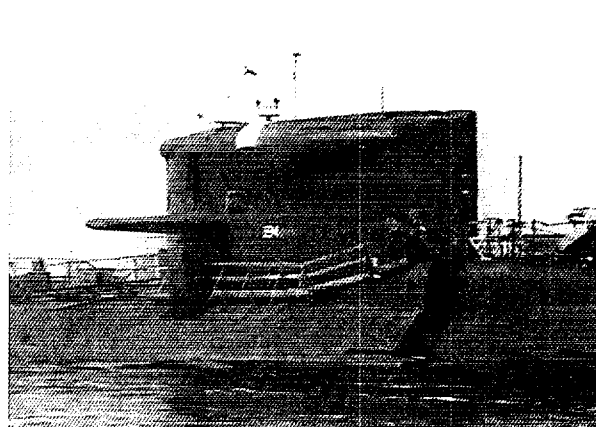

- The submarine is cut up to leave an extra compartment fore and aft of the reactor compartment;
- Only the reactor compartment is removed, to which pontoons are then fastened;
- The reactor compartment is filled with the buoyant substance polisterol, to help keep the reactor compartment afloat.

All three methods are intended to ensure that the

503 Kværner Moss Technology as., *Disposal of Russian nuclear submarines*, January 19, 1996.

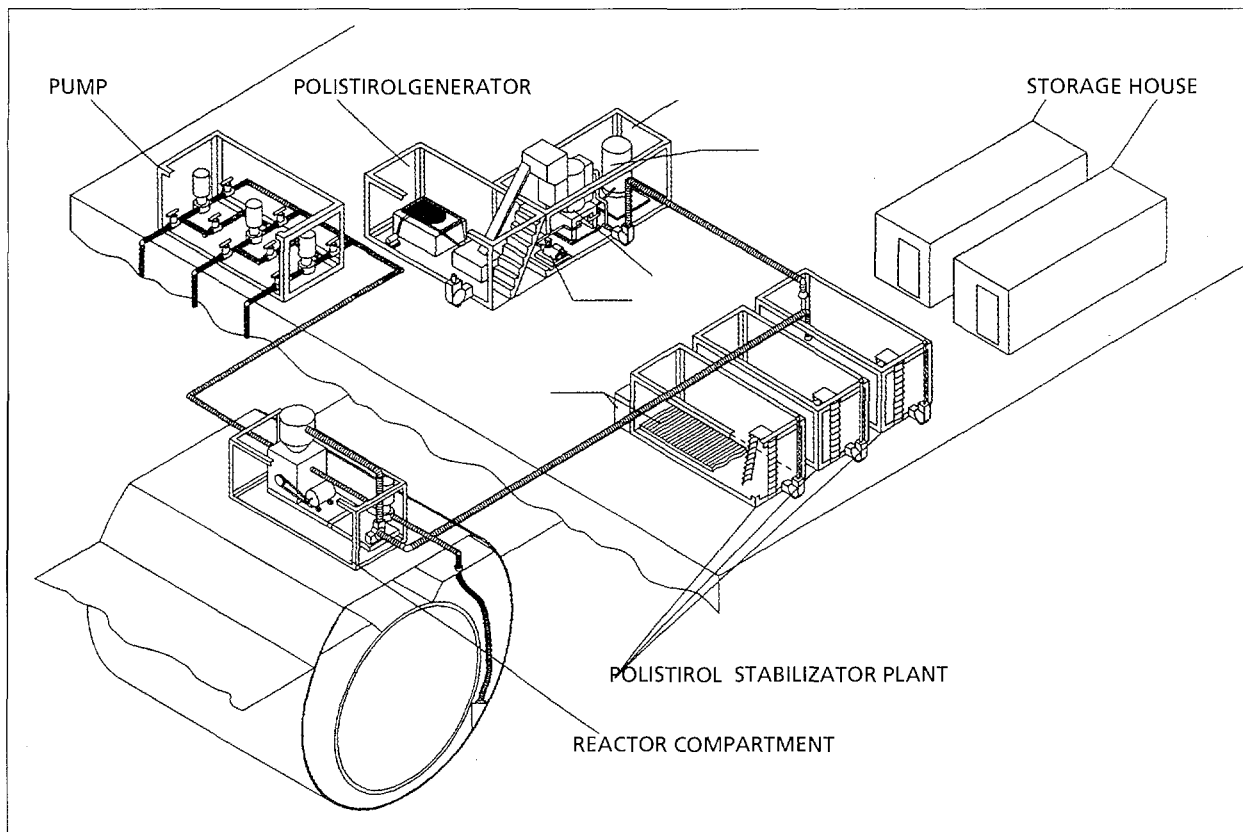

Drawing for a planned experimental plant for filling ballast tanks of nuclear laid up submarines with polystyrene to ensure their floating ability

reactor remains afloat for the purposes of transport and floating storage. The Russians claim that all three methods are guaranteed to keep the reactor compartments afloat for a minimum of ten years.⁵⁰⁴

The use of polystyrene eliminates the need for blowing compressed air into the compartments.⁵⁰⁵ This method has been developed by the state company Econol for the Rubin Central Design Bureau, and is a project supported and financed by the Russian Navy. If it is actually put into practice, naval yard no.10 Shkval in Polyarny will be assigned the work.

6.5.2 Dismantling submarines with damaged reactors

Six of the nuclear submarines that have been taken out of service have had accidents in which the fuel assemblies were damaged. Consequently, these vessels cannot be decommissioned in the normal way. Four belong to the Pacific Fleet and two to the Northern Fleet. The two

Northern Fleet vessels are K-192, factory no. 533 (Project 675 - Echo-II class) and K-64, factory no. 900 (Project 705 - Alfa class). The reactor compartment of the latter has already been removed. The four vessels from the Pacific Fleet are factory no. 175 and factory no. 180 of the Project 675 - Echo-II class, K-314, factory no. 610 of the Project 671 - Victor-I class, and K-66, factory no. 142 from the Project 659 T - Echo-I class.⁵⁰⁶ The design bureau Malakhit has developed plans for the decommissioning of these submarines and has applied to the Russian Navy for funding.⁵⁰⁷

Rubin Central Design Bureau also has proposed plans for decommissioning three Project 675 - Echo-II class vessels. These plans call for the use of specialised equipment to remove the nuclear fuel from the submarines. Removal of fuel from factory no. 175, a damaged Echo-II class vessel is deemed impossible.

After decommissioning, the reactor compartments of these vessels will be placed in interim storage with other more ordinary reactor compartments in tunnels in the

⁵⁰⁴ Program of complete disposal of Russian nuclear powered submarines decommissioned from the Northern Fleet, Energiya, October 1995.

⁵⁰⁵ Shukharov, F. N., vice president of the nuclear submarine construction centre Severodvinsk, presented in the document: *Problems of decommissioning of nuclear powered submarines and environmental protection in northern areas*, Severodvinsk March 15 - 16, 1995.

⁵⁰⁶ Shmakov, R. A., design bureau Malakhit, presentation of the document: *Problems of decommissioning of nuclear powered submarines and environmental protection in northern areas*, pp. 29 - 30, Severodvinsk, March 15 - 16, 1995.

⁵⁰⁷ Ibid.

⁵⁰⁸ Kvaerner Moss Technology as., *Disposal of Russian nuclear submarines*, January 19, 1996.

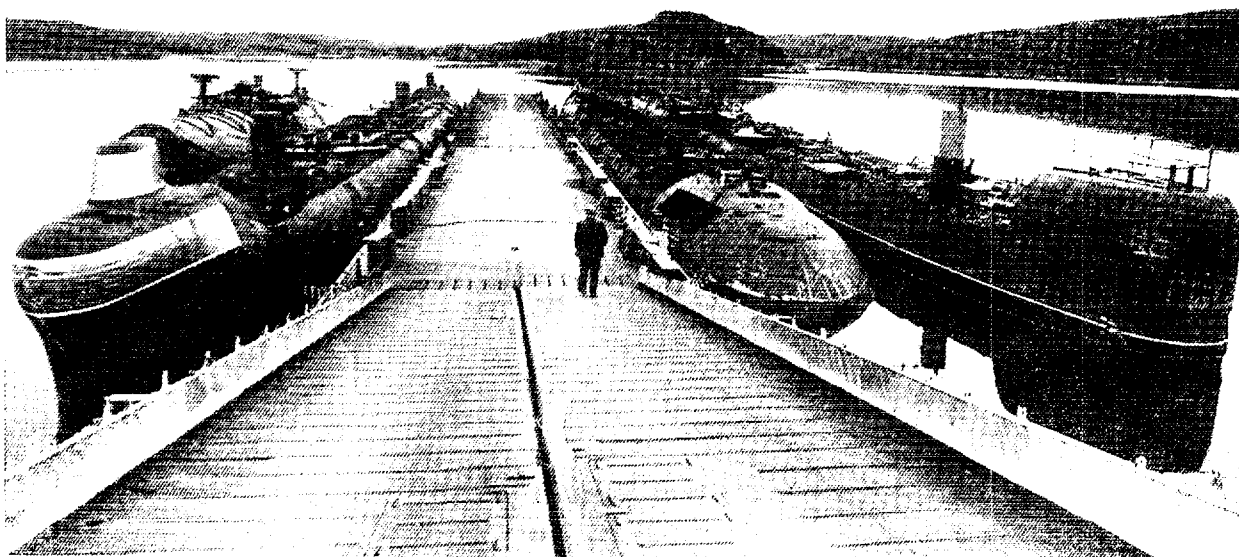

The reactor sections from decommissioned nuclear submarines are towed over water to these piers at Sayda Bay where they will be temporarily stored until a long term storage facility is established. At the very left edge of the picture is the reactor compartment from an Alfa class submarine. The three other hulls come from (left to right) Hotel class, Charlie class and Echo-I class vessels. Reactor compartments that are stored in this way may be kept afloat for an estimated ten years.

Ara Bay for a period of up to 100 years.⁵⁰⁸ An exception to this is the reactor compartment of K-64, Project 705 - Alfa class which will be stored at the dry dock in Gremikha.⁵⁰⁹

There may be other laid up submarines besides these six from which the nuclear fuel cannot be removed in the usual way. There are also six reactor compartments still containing their nuclear fuel that were dumped in the Kara sea. If these reactors are ever raised, they too will have to be decommissioned and stored in the proper fashion.⁵¹⁰

In addition to those vessels where reactor accidents have precluded normal defuelling procedures, the submarine K-162, factory no. 501 (Project 661 - Papa class) also presents problems. It is presently laid up in Severodvinsk. The K-162 is an experimental prototype from which the nuclear fuel cannot be removed in the same way as the more common reactor types. The equipment for defuelling the prototype has been lost and must be re-manufactured. As many as 50 fuel assemblies are allowed to remain in the reactor, in preparation for long-term storage.⁵¹¹

6.5.3 Transportation of reactor compartments

Reactor compartments which are processed in Severodvinsk and Nerpa are towed to Sayda Bay where they are moored to piers for temporary storage until a permanent

facility can be established. In 1994, four reactor compartments from Severodvinsk were towed here and another two were towed in the autumn of 1995. The distance from Severodvinsk to Sayda Bay is approximately 350 nautical miles. During the winter, all of the White Sea and parts of the eastern Barents Sea off the Kola Peninsula is ice covered. The reactor compartments are towed directly in the water, rather than aboard barges or other types of vessels. The danger of them sinking while under tow is greater than when moored in the Severodvinsk harbour basin. Usually two partial hulls with their reactor compartments are towed simultaneously.

One reactor compartment that was towed away in 1994 was loaded with solid nuclear waste. The same practice is anticipated for a number of reactors in the time to come. Again, it is the lack of storage capacity for solid radioactive waste in Severodvinsk that precipitates these kinds of measures. Furthermore, the Severodvinsk town administration have ruled that the total amount of radioactive waste stored in the city may not rise above present levels.⁵¹²

6.5.4 Plans for long term storage of reactor compartments.

The reactor compartments are kept afloat in the Sayda Bay pending the establishment of a permanent storage facility. No decision has yet been made as to how and

509 December 21, 1994 decision referred by Shmakov, R. A., the design bureau Malakhit, presentation of the document: *Problems of decommissioning of nuclear powered submarines and environmental protection in northern areas*, pp. 29 - 30, Severodvinsk, March 15 - 16, 1995.

510 Nilsen, T., and Böhmer, N., *Sources of Radioactive Contamination in Murmansk and Arkhangelsk Counties*, Bellona Report no.1 :1994.

511 Shmakov, R. A., design bureau Malakhit, presentation of the document: *Problems of decommissioning of nuclear powered submarines and environmental protection in northern areas*, pp. 29 - 30, Severodvinsk, March 15 - 16, 1995.

512 Nilsen, T., and Böhmer, N., *Sources of Radioactive Contamination in Murmansk and Arkhangelsk Counties*, Bellona Report no.1 :1994.

where this storage is going to be constructed. Several possibilities have been proposed and investigated.

The option of utilising one or more of the 400 meter tunnels in the Ara Bay on the Kola Peninsula for long term storage has received the most consideration. The tunnels were originally intended to conceal and shield strategic nuclear submarines, but were never completed. According to the current proposal, up to 100 reactor compartments could be stored in the tunnels.⁵¹³ Other sources claim that the plans call for storage of up to 130 reactor compartments in the Ara Bay tunnels.⁵¹⁴ Before the reactor compartments enter the tunnels, the pontoons both fore and aft will be removed. All currently accessible reactor compartments could be placed inside these tunnels by the year 2007.⁵¹⁵

A precondition for use is that the tunnels are dry. The project was approved by the Soviet Minister of Defence in 1990 and the first reactors were to be in place by 1994.⁵¹⁶ The Chernomorskaya yard in Sevastopol was to build derricks to lift the reactor compartments from barges to the tunnels. Storage permits were issued allowing storage of the reactor compartments in the tunnels for 70 to 100 years. After this period of time, radiation levels would have been significantly reduced allowing the compartments to be completely dismantled and the resulting scrap metal stored as ordinary solid nuclear waste.⁵¹⁷

Plans for utilising the Ara Bay tunnels for long term storage has met with criticism from many Russian agencies. The possibility of flooding in the tunnels resulting in leaks of radioactivity has been the cause of greatest concern. The storage facility would then be in conflict with Russian environmental regulations. Current laws prohibit the storage of radioactive waste in locations where there is a significant risk of leakage into the sea.

To safeguard against leakage from the tunnels at Ara Bay, the possibility of storing reactor compartments in the disused strip mining pits of Nikel has also been considered. This solution presupposes the building of a railway or a roadway of considerable size all the way from the coast. Andreeva Bay in Zapadnaya Litsa has also been considered as a possible long term storage location for reactor compartments. Both the latter locations entail considerable construction projects and the blas-

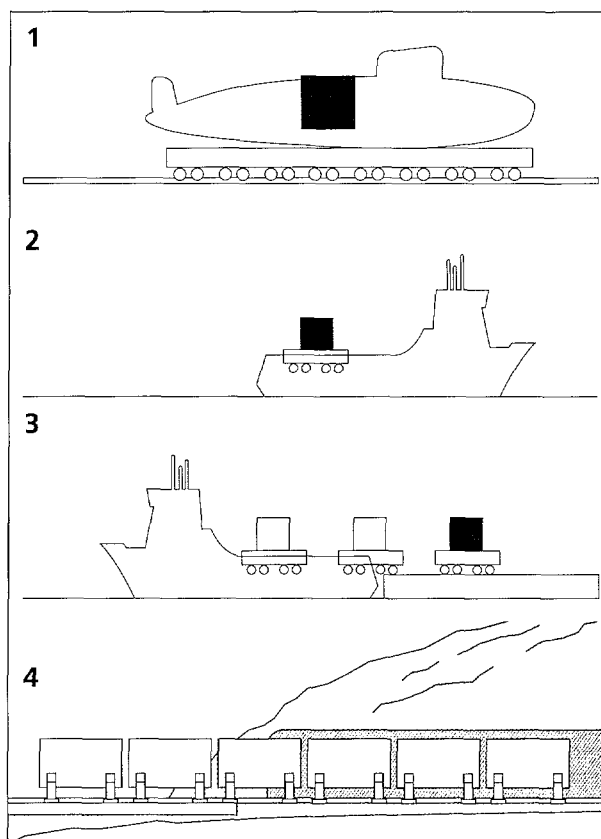

The illustration shows the planned way of handling reactor sections of decommissioned submarines. The first stage assumes cutting out of the reactor section (1). Then the reactor sections are loaded onboard transport vessel which delivers them to Ara-bay (2). In Ara-bay they are taken on-shore (3) and placed into the tunnels for long term storage (4).

ting of new tunnels, possibly even building large concrete structures.⁵¹⁸

A final possibility is storage in the permafrost at Novaya Zemlya. There are proposals to blast 2-3 kilometre long canals inland from the coast. The reactor compartments would then be towed up the canals. Once the canals had been filled with reactor compartments, dams would be built and the remaining water pumped out. Finally the reactor compartments, and possibly other types of radioactive waste, would be covered with sand and rock. According to Russian authorities, the permafrost will prevent the escape of radiation.⁵¹⁹

513 Consultations with representatives of Gosatomnadzor, Murmansk, February 1995.

514 Kværner Moss Technology as., *Disposal of Russian Nuclear Submarines*, January 19, 1996.

515 *Ibid.*

516 *Atomnaya Energiya*, Vol. 76, No. 5 - 1994.

517 Decommissioning obsolete submarines and storing reactor compartments. Paper presented at conference on Problems in decommissioning and dismantling of nuclear submarines, Moscow, June 19-22 1995.

518 Perovsky, V., *The possibilities for on shore storage of reactor sections*. (VNIPIET), St. Petersburg, 1995.

519 Kazakov, E. N., Moscow Institute of Industrial Technology, Oslo, December 1994.

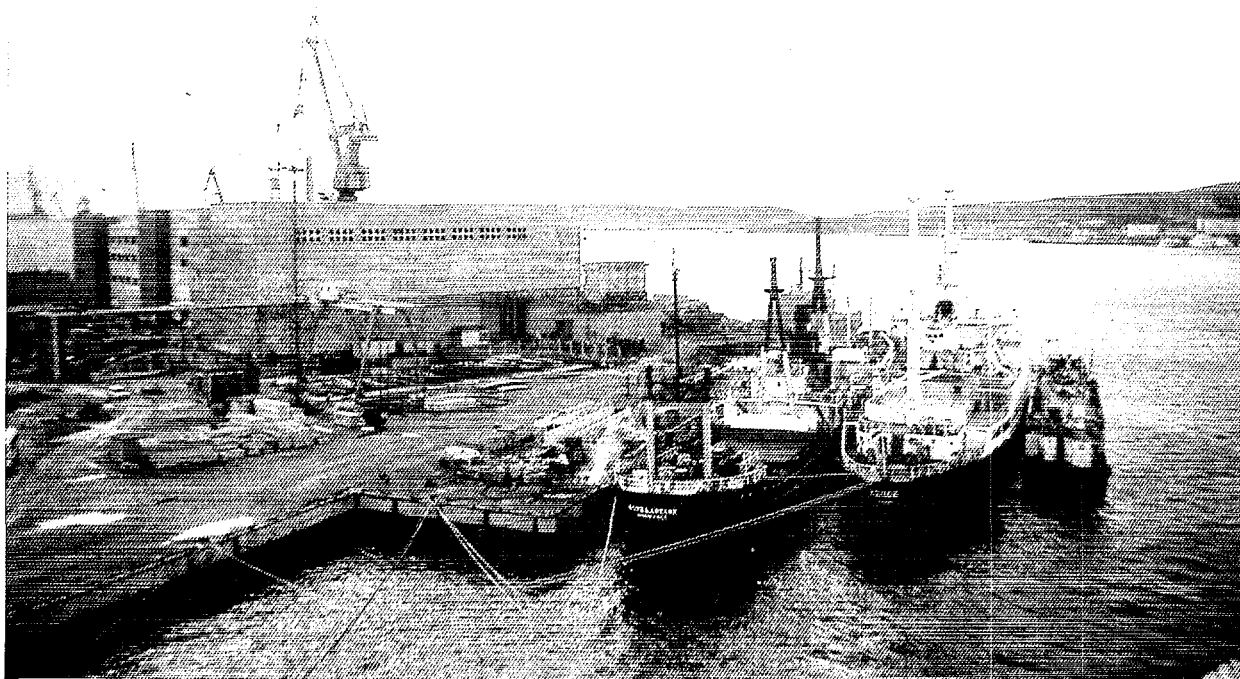

This purification plant for liquid radioactive waste belongs to *Atomflot*. It has an annual capacity of 1200 m³ of contaminated water. The capacity is expected to increase to 5 000 m³ annually as a result of a Russian-American-Norwegian co-operative project.

6.6 Radio ecological problems of dismantling

A nuclear submarine which has been prepared for dismantling contains that are radioactively contaminated to various degrees. More than 95% of the contaminated material comes from the reactor, representing approximately 7 % of the submarine volume.⁵²⁰

Usually, most of the liquid radioactive waste is drained from the reactor when the fuel assemblies are removed. The liquid waste constitutes about 200 m³. Twenty cubic metres comes from the primary coolant circuit, 4 m³ from filters, and 170 m³ from biological shielding tanks in the reactor compartment.⁵²¹

Considerable amounts of radioactive waste in the reactor compartment are concentrated on the inner surfaces of pipes and various tanks. Approximately 90% of the radioactivity is removed from the primary coolant circuit when the system is flushed after the initial draining. The radioactive waste thereby remains in liquid

form. The flushing of the primary cooling circuit produces about 100 m³ liquid waste with an activity of up to 3.7 TBq/l (10² Ci/l).⁵²² When decommissioning a twin nuclear reactor compartment, an additional 800 m³ of liquid nuclear waste is generated.⁵²³ The reason for the large volume of liquid waste is that water is used to continually flush the equipment and reactor parts to prevent them from becoming unnecessarily contaminated.⁵²⁴

Investigations of reactor compartments 3-5 years after removal of the nuclear fuel show that 90% of the remaining activity is represented by long life isotopes, 10¹³ to 10¹⁵ Bq in total. The primary cooling circuit contains as much as 4 x 10¹⁰ Bq in transuranium elements. Because of the varying reactor designs between the different classes of submarines, these values can vary to a large extent. Examination of hulls in which at least three compartments were remaining show gamma radiation higher than the permitted threshold values.⁵²⁵

There is no operational treatment plant for liquid radioactive waste at either Severodvinsk or Nerpa. The civilian icebreaker base *Atomflot* in Murmansk has one facility with an annual capacity of 1 200 m³. A trilateral

520 *Atomnaya Energiya*, Vol. 76, No. 5 - 1994.

521 Kvaerner Moss Technology as., *Disposal of Russian nuclear submarines*, January 19, 1996.

522 *Decommissioning obsolete submarines and storing reactor compartments*. Paper presented at conference on *Problems in decommissioning and dismantling of nuclear submarines*, Moscow, June 19-22, 1995.

523 Kvaerner Moss Technology as., *Disposal of Russian Nuclear Submarines*, January 19, 1996.

524 *Atomnaya Energiya*, Vol. 76, No 5, - 1994.

525 *Decommissioning obsolete submarines and storing reactor compartments*. Paper presented at conference on *Problems in decommissioning and dismantling of nuclear submarines*, Moscow, June 19-22, 1995.

Norwegian-American-Russian project is underway to expand this capacity to 5 000 m³ yearly. The Russian Pacific Fleet possesses equipment for treating liquid radioactive waste, and a similar solution is planned for Severodvinsk.⁵²⁶ The technology in such treatment is based on transferring the activity in the liquid medium to filters which can be treated as solid waste, but in much smaller volume.

⁵²⁶ Ibid.

Handling of spent fuel assemblies

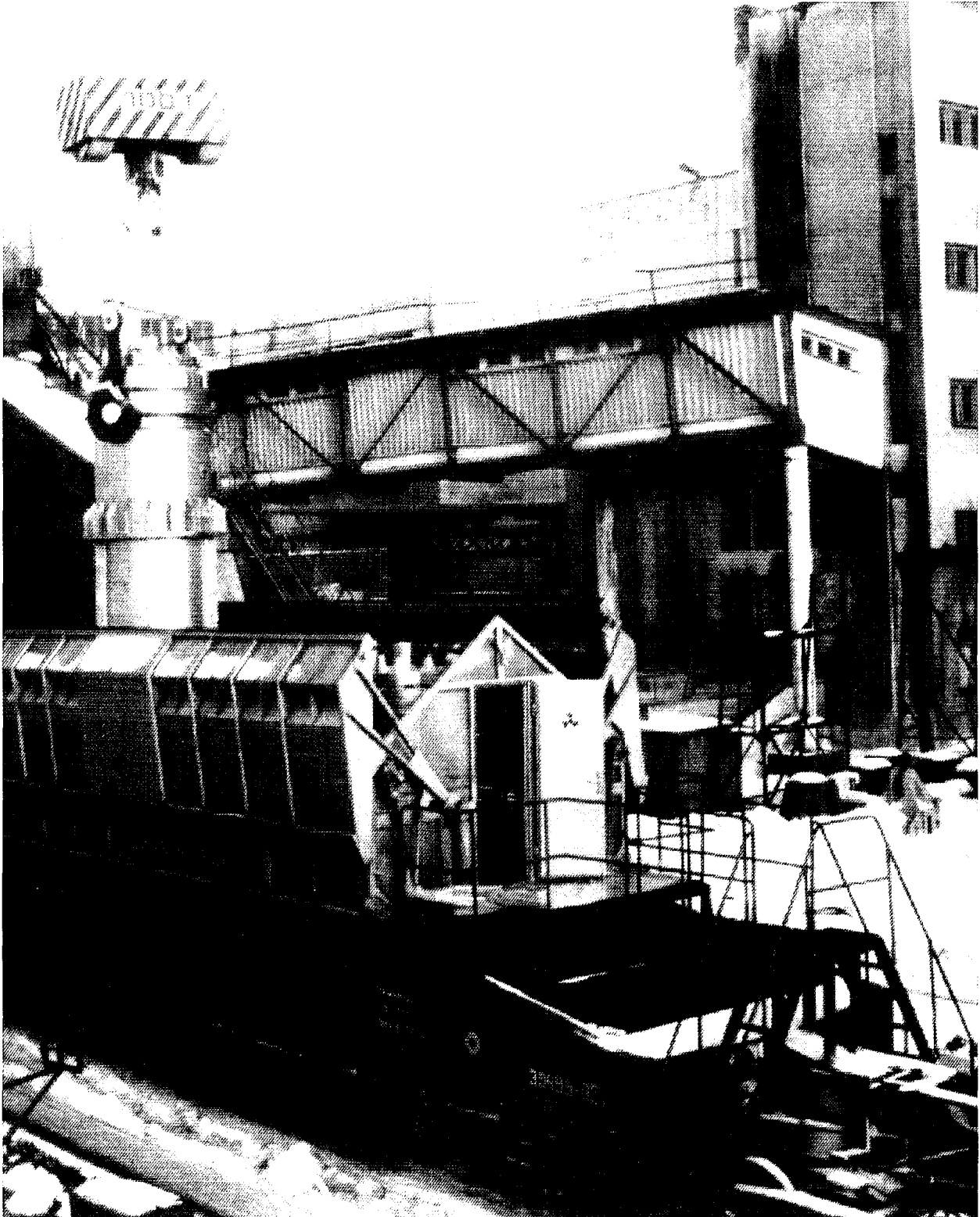

Handling of spent fuel assemblies

7.1

Organisation and Responsibility

In accordance with the “closed cycle” which was the policy of the former Soviet Union, the expectation is that all spent nuclear fuel should be reprocessed and used again. Behind this policy lay the expectation of a uranium shortage in the future. In reprocessing procedures, the spent nuclear fuel assembly is dissolved in an acid solution, and uranium and plutonium is separated from the other elements. This uranium can then be used in the production of new fuel assemblies. To that end, a resolution was passed in the middle of the 1960s to build a production facility at the Mayak Chemical Combine for the reprocessing of spent nuclear fuel. This was the beginning of the RT-1 reprocessing facility.⁵²⁷

The first technological system for the reprocessing of spent nuclear fuel both from VVER type pressurised water reactors (nuclear power plants) and from naval reactors (nuclear icebreakers and submarines) was started in 1976. Spent fuel assemblies were removed from the reactors and forwarded to the RT-1 reprocessing facility on special railroad cars. In 1973, the first specially modified train from the Northern Fleet consisting of nine cars, ran from Murmansk to Mayak.⁵²⁸

Because the storage facilities for spent fuel assemblies located at Andreeva Bay and at Gremikha are not connected to the railway, there were two steps in the process of forwarding spent fuel assemblies from the submarine reactors to the reprocessing facility at Mayak:

1. Establishment of a loading area whereby containers of spent nuclear fuel could be transferred from Northern Fleet service ships and transported to the railway;
2. Preparation of service ships to carry the containers of spent nuclear fuel by sea from Andreeva Bay and Gremikha to the transfer loading area.

Four locations were considered as possible transfer loading points: Severodvinsk (the harbour area), Seve-romorsk (the military building battalions pier near the industrial area of the ZhBI factory), Trifonov Creek, and Murmansk (Nizhnaya Rosta). The latter was finally selected (the surface storage area of Military Department 31326) because of the existence of a second railway track.⁵²⁹

An added benefit of the location was the presence of qualified technical expertise, for this was also the location of Sevmorput Shipyard Military Department 31326. Furthermore, Nizhnaya Rosta was situated close to Base 92 (today known as RTP Atomflot) where the Murmansk Shipping Company moored its nuclear icebreaker *Lenin* and was awaiting delivery of several more.⁵³⁰ This company too would need a transfer loading area to receive spent nuclear fuel assemblies from the icebreaker reactors.

Barge-4 was the vessel selected to transport the containers of spent nuclear fuel over water. This barge lacked an engine and had a displacement of 600 tonnes. *Barge-4* contained storage compartments, one of which was also equipped to store 39 containers of spent fuel assemblies. Furthermore, *Barge-4* had a dosimeter reading station, sanitary facilities for the ship's personnel and cabins for a military crew of nine. *Barge-4* was dumped in the Kara Sea in 1988.⁵³¹ Operations to forward spent nuclear fuel from the bases to the reprocessing facility at Mayak were organised in the following manner:

1. Empty containers were first secured from BTB (a land-based technical facility) and forwarded to Andreeva Bay and Gremikha. At Andreeva Bay and Gremikha the containers were loaded with spent nuclear fuel assemblies which had been stored for a minimum of three years.⁵³²
2. The spent fuel assemblies were examined, and documents were issued confirming that they were in condition acceptable for transportation. The containers

527 Böhmer, N., and Nilsen, T., *Reprocessing Plants in Siberia*, Bellona Working Paper No. 4-1995.

528 Ibid.

529 Perovsky, V. A. 1995.

530 Ibid.

531 Nilsen, T., and Böhmer, N., *Sources of Radioactive Contamination in Murmansk and Arkhangelsk Counties*, Bellona Report no.1 :1994.

532 The Environmental Committee of Murmansk, Branch of Radiation Safety, Murmansk 1993.

were then sealed and decontaminated to permissible levels for transport. They were subsequently hoisted aboard *Barge-4* and transported along the Kola coast to Pier No. 20 at Military Department 31326 at Rosta in the Kola Fjord.

3. At the same time, a special train arrived from Mayak with a consignment of empty railroad transport container cars. The cars were shunted one at a time onto a side track at Military Division 31236 to transfer the transport containers from the ship to the train. The remaining cars were stationed on the service tracks of Sevморпут Shipyard.
4. The loading transfer points on the territory of Military Department 31326 changed according to a schedule and the transfer of containers followed it. Empty containers were transferred to the barge while those that were loaded were lifted onto the specially constructed railroad cars destined for Mayak.
5. The actual work of transferring the containers was done by military personnel from the loading facility. Assisting operators (such as the crane operators, mechanics, etc.) were drawn from civilian personnel working for Military Department 31326.

The technical department of the Northern Fleet was generally in charge of the work. The process of transferring the transport containers from the barges to a special train required 7-8 working days on average. Between five and ten special trains per year were handled,⁵³³ with the first special train going from Murmansk to Mayak in 1973. This train had nine cars. In later years there were trains with as many as 22 cars.⁵³⁴ Up until 1994, there was no financial arrangement between the Northern Fleet and Mayak Chemical Combine. Responsibility was divided between the two concerns in the following manner:

- The technical department of the Northern Fleet was in charge of loading the service ships and ensuring and approving that the security regulations for spent nuclear fuel were followed. The department was responsible for ensuring that the spent fuel assemblies were correctly packed in the transport containers. The Northern Fleet was also in charge of transport from the storage facilities at Andreeva Bay and Gremikha to the transfer point at Rosta and the subsequent loading onto the special trains to Mayak.
- Mayak Chemical Combine was responsible for sending empty transport containers in the special train to the transfer loading docks in Rosta. Once the special train had arrived in Mayak, Chemical Combine authorities arranged for the unloading of the full contain-

ers as well as further intermediate storage and ultimately, reprocessing. Mayak owns the special railway cars and is responsible for ensuring that they are in good technical condition.⁵³⁵

The schedule of the special trains was determined by a special committee from Minatom. Minatom was also responsible for co-ordinating the transfer loading procedures. In the period from 1973 to 1994, at least 115 special trains made the journey from Rosta to Mayak, although the number of trains per year gradually decreased. In the period from 1973 to 1983 there were 58 trains. An overview of the number of special transport trains from 1984 to 1994 is given in the table.⁵³⁶

1984	10	special trains,	586 containers
1985	9	special trains,	503 containers
1986	3	special trains,	155 containers
1987	7	special trains,	386 containers
1988	6	special trains,	329 containers
1989	7	special trains,	426 containers
1990	4	special trains,	235 containers
1991	3	special trains,	216 containers
1992	3	special trains,	216 containers
1993	4	special trains,	280 containers
1994	1	special trains,	12 containers type TK 18
1995	4	special trains,	48 containers type TK 18 ⁵³⁷

According to local sources and people who took part in the operations, every step associated with the transport of spent nuclear fuel was strictly monitored by the Northern Fleet security authorities. Throughout the time that spent nuclear fuel was transported through Murmansk there were no breaches of radiation safety rules or pollution of the reloading area, even though there were certain problems now and then.⁵³⁸ Though the special trains from Rosta to Mayak ran on the regular Russian railway network, special safety measures were in effect and the Mayak trains were slower than ordinary trains.

7.2 Russian Submarine Fuel

The fuel assemblies for Russian nuclear submarines powered by pressurised water reactors are manufactured at the Machine-Building Plant in Electrosal outside of Moscow. The fuel assemblies for liquid metal cooled reactors (submarines of type 705 (Alpha class) and type

533 Murmansk Shipping Company, Dep. for nuclear Safety, 1993.

534 Böhmer, N., and Nilsen, T., *Reprocessing Plants in Siberia*, Bellona Working Paper No. 4-1995.

535 Ibid.

536 All the figures are from Murmansk Shipping Company Dep. For Nuclear Safety, with the exception of the year 1995.

537 Severny Rabochy, 1995.

538 Murmansk Shipping Company Dep. For Nuclear Safety

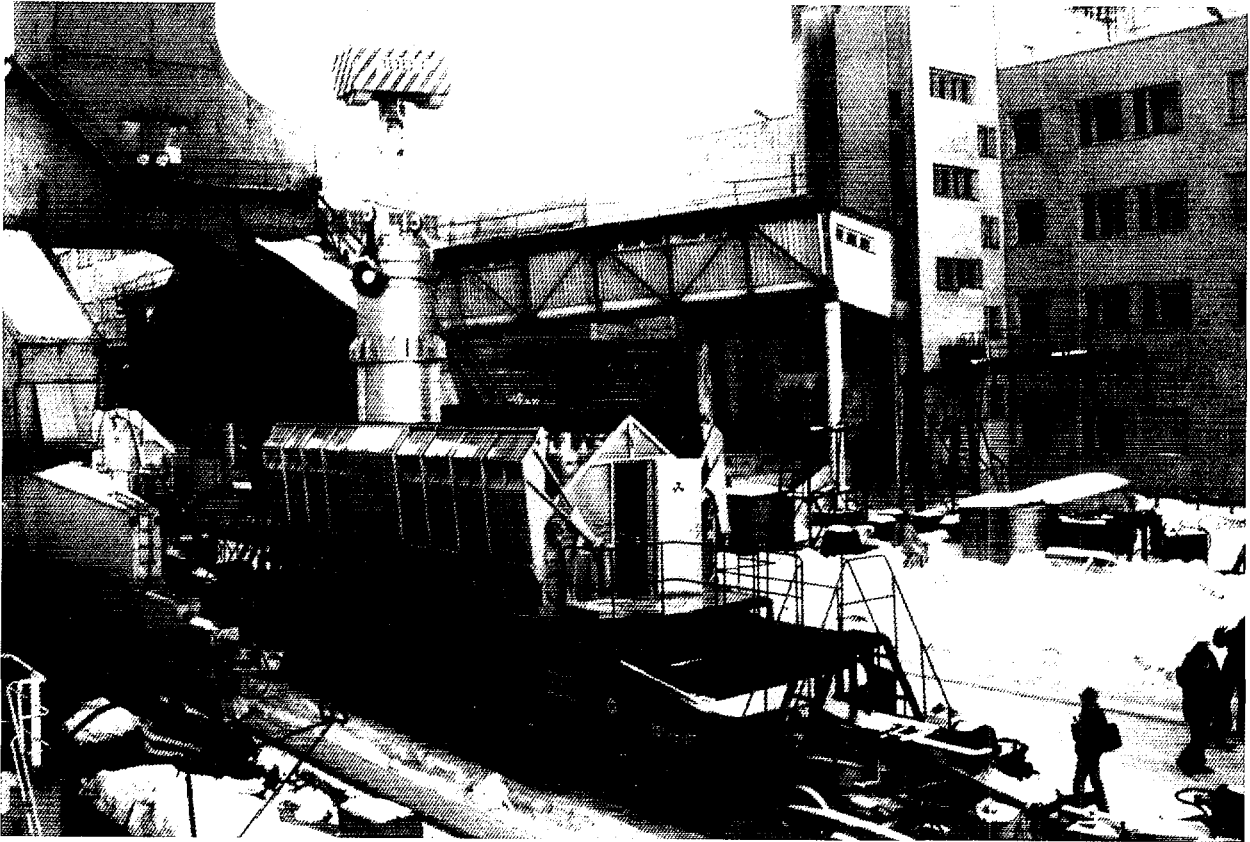

Containers of spent fuel assemblies are loaded into TUK-18 railway cars for transport to the reprocessing facility RT-1 in Mayak. This picture is from the civilian nuclear icebreaker base *Atomflot* in Murmansk.

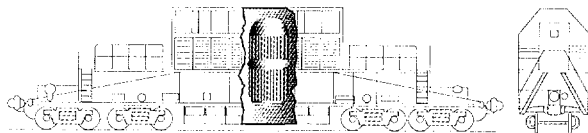

645-ZhTS) were manufactured at Ulbinsky Metallurgical Factory at Ust-Kamenogorsk in Kazakhstan.⁵³⁹

The reactor core of a Russian nuclear submarine has between 248 and 252 fuel assemblies, depending upon the type of reactor. Most Russian nuclear submarines have two reactors. Each fuel assembly consists of several tens of fuel rods. The design of these fuel rods varies from the traditional round rods to advanced flat plates.⁵⁴⁰ Most of the uranium fuel is clad in steel or zirconium.⁵⁴¹

The enrichment of fuel in pressurised water reactors varies from 21 percent of ^{235}U in first and second generation nuclear submarines to 43–45 percent of ^{235}U in third generation nuclear submarines.⁵⁴² Certain pressurised water reactors have fuel with even higher enrich-

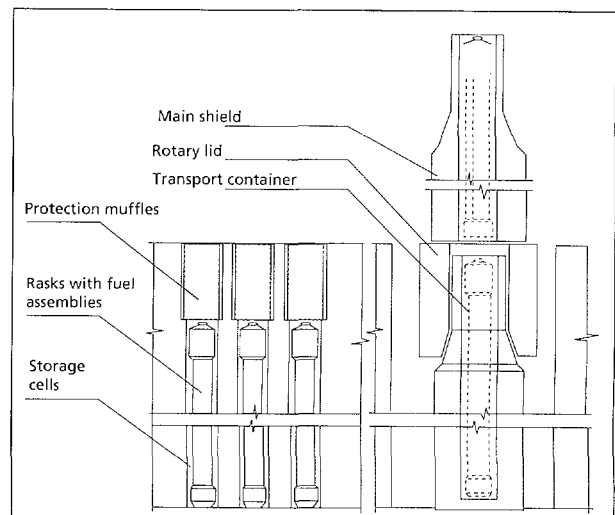

The drawing shows placing of containers with used nuclear fuel at the storage facility of Andreeva Bay.

ment. For example, the Pacific Fleet's nuclear-powered communication ships of type 1941–Kapusta class have reactor cores enriched to 55–90 percent of ^{235}U . The enrichment of fuel assemblies in liquid metal cooled reactors can be as much as 90 percent.⁵⁴³ Only fuel from submarines with pressurised water reactors is stored at Andreeva Bay. Hence the enrichment of most of the fuel

539 Bukharin, O., and Handler, J., 1995.

540 Ibid.

541 Nilsen, T., and Böhmer, N., *Sources of Radioactive Contamination in Murmansk and Arkhangelsk Counties*, Bellona Report no.1 :1994.

542 Bukharin, O. and Handler, J., 1995.

543 Ibid.

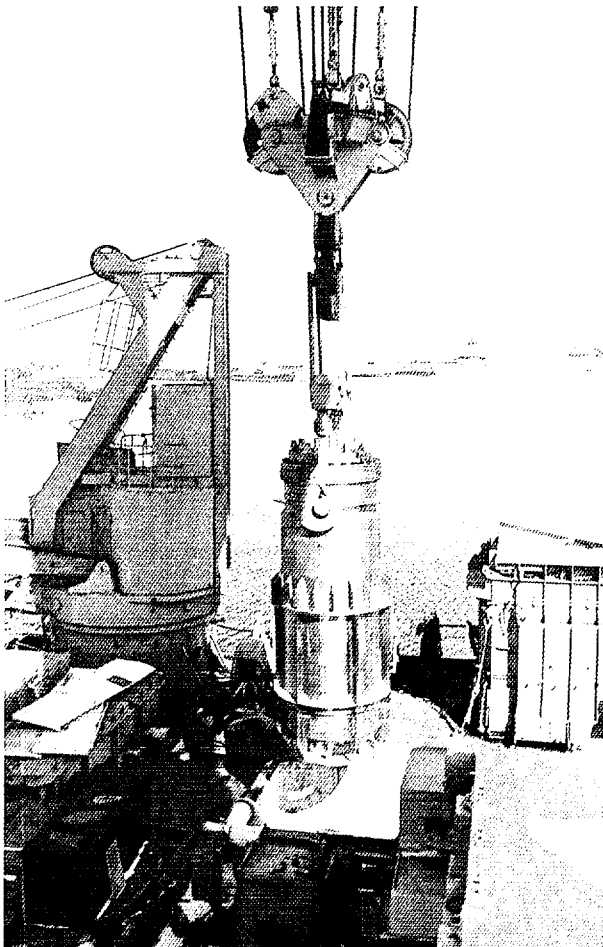

The unloading of container with used nuclear fuel from service ship project 2020 Malina class takes place at on of Severodvinsk Shipyards. This operation is considered as potentially dangerous since there is a high probability of a spontaneous chain reaction in case of an accident.

in the dry storage facilities does not exceed 45 percent of ^{235}U . Spent nuclear fuel from submarines with liquid metal cooled reactors is stored at Gremikha. Even so, it is worth noting that there is a submarine of type 705-Alpha class laid up at Zapadnaya Litsa with fuel still remaining inside its reactor. This is also true of a reactor compartment in Severodvinsk.

The reactor core in third generation nuclear submarines consists of fuel assemblies with different degrees of enrichment. The fuel assemblies towards the centre of the reactor core are enriched to 21 percent ^{235}U , while those near the edge of the reactor core are enriched up to 45 percent ^{235}U . The reactor of a third generation nuclear submarine contains about 115 kg of ^{235}U . Second generation nuclear submarine reactors contain a total of 350 kg of uranium, of which 70 kg are ^{235}U .⁵⁴⁴ A typical reactor core in the first generation of nuclear submarines has about 50 kg of ^{235}U of a total 250 kg of uranium. This is reportedly also the amount of uranium present in each of the reactors that were dumped

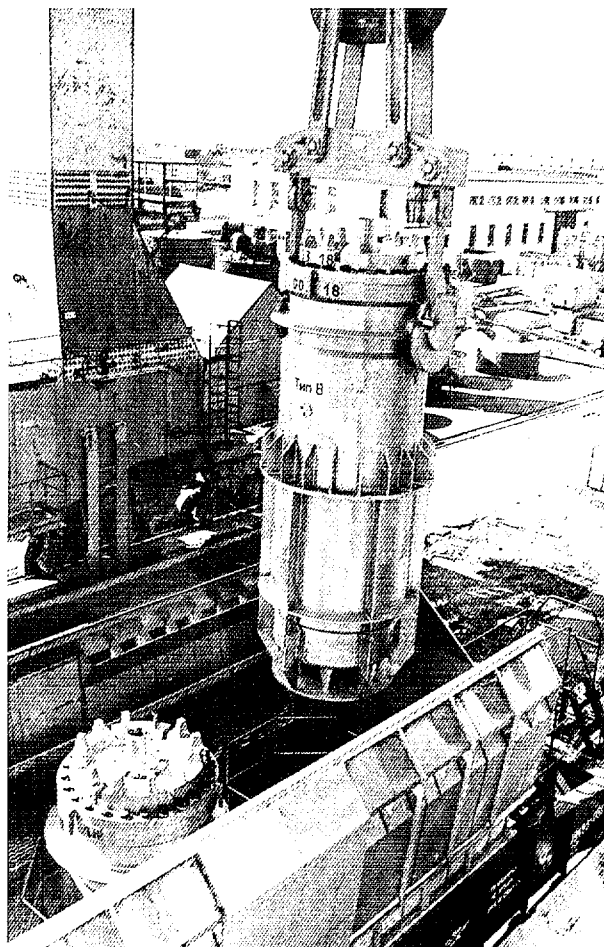

Container with used nuclear fuel is transferred from the service vessel to one of the special wagons. In Severodvinsk the loading operations are conducted by crane which has poor technical condition, so most of the time it is under repair. On the background there are four transport containers for nuclear fuel.

into the Kara Sea while still containing their nuclear fuel.

7.3 Transport containers⁵⁴⁵

In accordance with Minatom and Navy rules, TUK ("transport packing container") containers are used to transport spent nuclear fuel. Each TUK consists of two parts: a protective cover (the outward container) and a closed cylinder (internal casing). TUK-11 and TUK-12 containers were used for all reloading of fuel from nuclear vessels until 1993, and in 1994 they were replaced by the TUK-18 container. The TUK-11 and TUK-12 containers were manufactured in 1971-72 by the Uralmash factory in Ekaterinburg. The main difference between the two types of containers is in the height. Each container held one holster in which seven fuel

⁵⁴⁴ *Ibid.*

⁵⁴⁵ Unless otherwise stated, all the information in this chapter are from Office of Technology Assessment, *Nuclear waste in the Arctic and other regional impacts from Soviet nuclear contamination*, 1995.

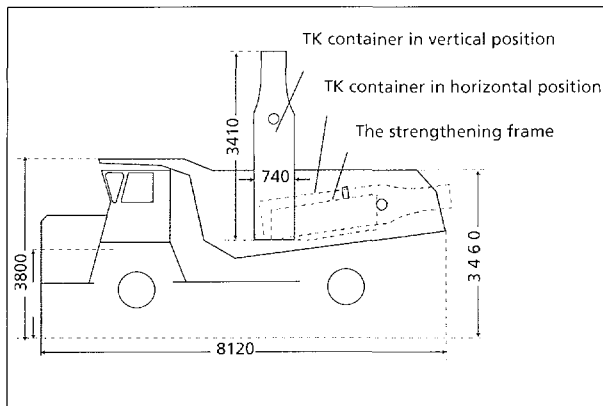

The drawing shows how transport-container type 12 is placed on the lorry «Belaz».

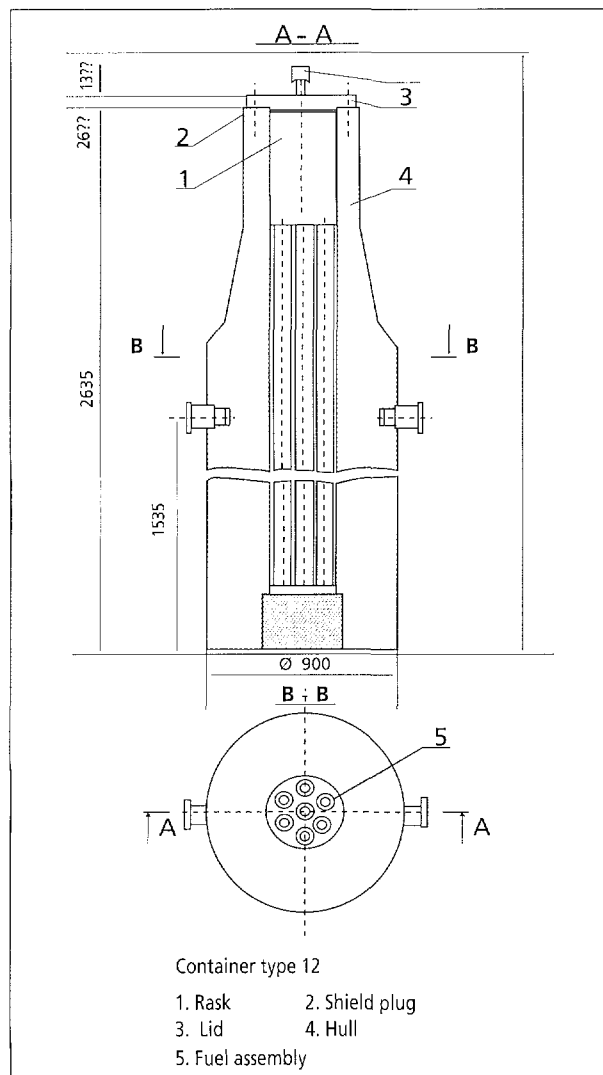

assemblies had been packed. (The cylinders for Murmansk Shipping Company held three to five fuel assemblies). The containers were made of stainless steel, weighed 8 850 kg each and were 327 mm thick. The

closed cylinders were also made of stainless steel, and weighed 260 to 300 kg when fully equipped. The TUK-11 and TUK-12 containers were transported on TK-4 railroad cars, each of which could hold four containers. In this way, a special train of nine or ten cars could transport one reactor core; a special train of 18–20 cars could take a maximum of two reactor cores.

In 1993 the TUK-11 and TUK-12 containers had become obsolete, and from 1994 onwards, TK-18 (TUK-18) containers have been exclusively used for the transport of spent naval fuel. The TK-18 containers were manufactured by the Izhorsky factory in the city of Kolpino. These too are made of stainless steel, and a single container weighs 40 tonnes with a thickness of 320 mm. Each TK-18 container holds up to seven closed cylinders, and each cylinder can take five to seven fuel assemblies. In 1989, four special railroad cars of the type TK-VG-18 were built at the Kalininsky Coach Works (now part of Mayak Chemical Combine) to transport the TK-18 containers. A TK-VG-18 car takes three TK-18 containers. The Russian Navy has 50 of these containers, half of which are owned by the Northern Fleet.⁵⁴⁶ A special train pulling four TK-VG-18 cars with their full capacity of twelve TK-18 containers is capable of transporting two to three reactor cores.⁵⁴⁷

7.4 Transport Routes

From 1973 to 1984 sea transport of spent nuclear fuel assemblies went over the following routes:⁵⁴⁸

- Andreeva Bay–Murmansk;
- Gremikha–Murmansk;
- Severodvinsk–Murmansk.

Since 1984, as a result of the cessation of activities of the storage facility for spent nuclear fuel from pressurised water reactors at Gremikha, sea transport has taken place only from Andreeva Bay. Until 1978, *Barge-4* was used for all sea transport of spent nuclear fuel. In 1979–1980, due to its technical condition, *Barge-4* was written off from the fleet of service ships. After its decommissioning, it was filled with solid radioactive waste from the Northern Fleet and dumped in the Kara Sea.⁵⁴⁹ Beginning in 1979, containers of spent nuclear fuel assemblies were transported on the Northern Fleet service ship *Severka*. This ship is a modified vessel of the Tissa class and was built in Hungary. *Severka* has three cargo holds and a capacity of up to 88 TUK-11 and TUK-12 containers. However, it is unsuitable for

546 Murmansk Shipping Companya dep. For Nuclear Safety, 1993.

547 Izvestia, March 14 1995.

548 Office of Technology Assessment, September 1995.

549 Yablokov, A. V. Et. Al., *Facts and problems related to dumping of radioactive material in the seas adjacent to the territory of the Russian Federation*, 1993.

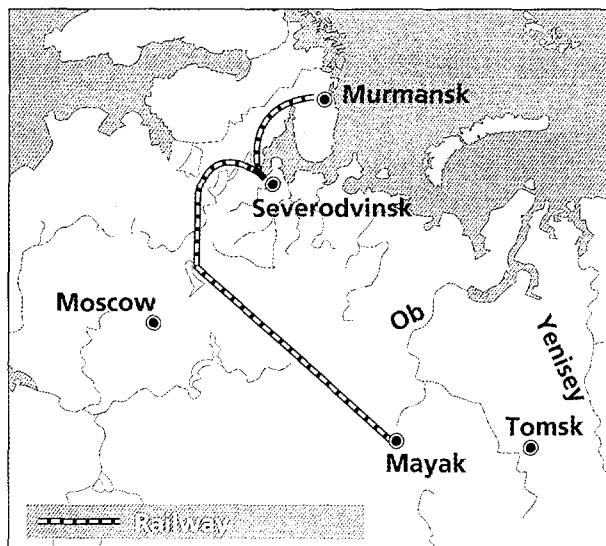

Map 8. Transport route for spent nuclear fuel from the Kola Peninsula to Mayak in the Southern Urals. The fuel assemblies are transported from the Kola Peninsula naval bases and from the naval yards at Severodvinsk to Murmansk on the Northern Fleet's Project 2020 - Malina class service ships, whereas they are transported from Murmansk to Mayak on TUK-18 type railroad cars.

TK-18 containers, and has subsequently been laid up.⁵⁵⁰

Until 1993, all rail transport of spent nuclear fuel by rail originated from Murmansk. No less than a third of the spent fuel assemblies originate from Zvezdochka Shipyard in Severodvinsk. These fuel assemblies may be categorised as "cold". In an effort to reduce the number of unnecessary transfers and to accelerate the defuelling of laid up submarines, Rear Admiral E. Rogachev (then in charge of the technical department) proposed to transport the spent nuclear fuel directly from Severodvinsk for reprocessing. Loading the containers would take place at sea on board technical service ships of the type 2020-Malina class. The proposal was adopted in December, 1991, by the Commander in Chief of the Northern Fleet Admiral F. Gromov (now Commander in Chief of the Russian Navy) and approved by the management of Minatom.⁵⁵¹ According to the specialists, a direct transfer of spent nuclear fuel to the reprocessing facility would permit the complete defuelling of all of the twelve laid up submarines in the course of three years. However, a lack of co-ordination and departmental conflicts between the local Minatom offices, city councils, factory management and the military had the result that so far, only one special train has

departed for Mayak, in May 1994. Nonetheless, according to the specialists, plans for transporting spent nuclear fuel directly from Severodvinsk in the future remain unchanged.

Even greater expectations are pinned on the opening of a transport route from the base facility Nerpichya at Zapadnaya Litsa. Many knowledgeable people working on these kinds of problems consider Nerpichya to be the ideal place from which to transport containers of spent nuclear fuel, including the TK-18 containers. Nerpichya has its own wharf, a 125 tonne naval crane and railway tracks down to the wharf.⁵⁵² The railway track is not yet in use, and it is unclear when the connection will be completed.⁵⁵³

A little further out in the Litsa Fjord is the Northern Fleet's main storage facility for spent nuclear fuel. There the main problem is the lack of container ships capable of transporting TK-18 containers. It is believed that OKTB *Vokshod* at Sevморput Shipyard in Murmansk is in the process of developing such a ship, and it could possibly be built at Sevморput in 1996-97.⁵⁵⁴

After 1973, the use of transportcontainers of type TK-11 and TK-12 was forbidden, and the loading area for spent nuclear fuel was moved from Sevморput Shipyard to the civilian nuclear icebreaker base Atomflot.⁵⁵⁵ At this base there was already cranes that could handle the containers for spent nuclear fuel. Atomflot has re-constructed the storage-ship *Lotta* so that it can handle the new containers of TK-18 type. *Lotta* was built in 1961 and has 12 room for storage of 68 containers with spent nuclear fuel.⁵⁵⁶ Three train-set loaded with spent nuclear fuel was transported away from Atomflot in 1995. About half of the spent fuel was from the Northern Fleet, while the other half was from nuclear icebreaker at Murmansk Shipping Company.⁵⁵⁷

7.5 Financial aspects

Over the last three to four years, the tempo at which spent nuclear fuel is transported and processed has slowed drastically.⁵⁵⁸ This is largely due to a sharp increase in the cost of transporting and reprocessing spent nuclear fuel following a change in the billing policy of Mayak Chemical Combine. Starting from January 1,

550 Perovsky, V. A. 1995.

551 *Problems of Decommissioning of Nuclear Powered Submarines and Environmental Protection in the Northern Areas.* Severodvinsk March 15 - 16, 1995.

552 *Murmansky Vestnik*, September 2, 1995.

553 Information given on a press conference at Atomflot, regarding transport of spent nuclear fuel, March 1995.

554 Perovsky, V. A., 1995.

555 Information given on a press conference at Atomflot, regarding transport of spent nuclear fuel, March 1995.

556 Nilsen, T., and Böhmer, N., *Sources of Radioactive Contamination in Murmansk and Arkhangelsk Counties*, Bellona Report no.1 :1994.

557 Severny Rabochny, 1995.

558 *Krasnaya Zvezda*, March 15, 1995.

1991, Mayak Chemical Combine required full coverage of its expenses.⁵⁵⁹ In May, 1995, it cost the Northern Fleet and Murmansk Shipping Company 5-6 billion roubles to process two reactor cores, even though the real cost of processing that amount of fuel was 8-9 billion roubles.⁵⁶⁰ The management of the Combine admits that the reprocessing of naval nuclear fuel represents a loss for Mayak. The extra costs are financed entirely by foreign currency earned by reprocessing spent nuclear fuel from foreign nuclear power stations. Nowadays, Mayak organises a special train only after having received payment in advance from the customer, regardless of who the customer is.⁵⁶¹ Pointed questions are asked by the Interdepartmental Commission for Environmental Safety. Academician A. Yablokov states flatly that Russia simply lacks the necessary government level resolutions on the importance of reprocessing spent nuclear fuel as well as ecological and economical evaluations of closed and open nuclear fuel cycles.⁵⁶²

The Russian Navy lacks funds to pay for the services of Mayak Chemical Combine, and at present, this constitutes the most important reason for the drop in the rate at which spent nuclear fuel is reprocessed. Thus there is a sharp increase in the amount of spent nuclear fuel that is stored at the naval bases, including fuel that remains in the reactors of laid up submarines. Specialists and the commanders of the fleet are both greatly concerned about this situation, for in theory it will be impossible to transport all this fuel to Mayak over the course of the next 30 to 40 years. In addition to this comes the spent

fuel that Mayak Chemical Combine cannot accept for reprocessing, including:

- All spent nuclear fuel from reactors with liquid metal cooled reactors;⁵⁶³
- Defective fuel assemblies, that is, parts that are bent or have broken cladding. This is especially true of the fuel assemblies that are stored in Storage Pool No. 1 at Gremikha and at unshielded locations at Gremikha and Andreeva Bay;⁵⁶⁴
- Furthermore, there are a number of submarine reactors with damaged fuel assemblies, for example, K-192 (former K-131) at Shkval Shipyard.⁵⁶⁵

Many experts believe that about 10% of the fuel assemblies accumulating at Northern Fleet bases and shipyards cannot be reprocessed.

In addition there are also 52 nuclear submarines that have been taken out of operation in which the used fuel has not been removed from the reactor.⁵⁶⁶ Fifty of these submarines have two reactors each, so that the total number of reactors with fuel elements is 102. As mentioned earlier, there are about 248 to 252 fuel elements in each reactor core. Many of these submarines have been taken out of operation for as long as 15 years. Because it is not possible to monitor the conditions of these fuel elements, it is impossible to tell how many of them may be damaged. Therefore, it may be possible that the amount of spent nuclear fuel that cannot be transported to RT-1 for reprocessing in the standard way is much higher than 10% as earlier assumed.

559 Nilsen, T., and Böhmer, N., *Sources of Radioactive Contamination in Murmansk and Arkhangelsk Counties*, Bellona Report no.1 :1994.

560 *Krasnaya Zvezda*, March 15, 1995.

561 Information given on a press conference at *Atomflot*, regarding transport of spent nuclear fuel, March 1995.

562 Footnote on a resolution document from March 1, 1995, No. 15.

563 The Environmental Committee of Murmansk, Branch of Radiation Safety, Murmansk 1995

564 Information given on a press conference at *Atomflot*, regarding transport of spent nuclear fuel, March 1995.

565 *Ibid.*

566 *Komsomolskaya Pravda*, June 23, 1995.

Nuclear submarine accidents

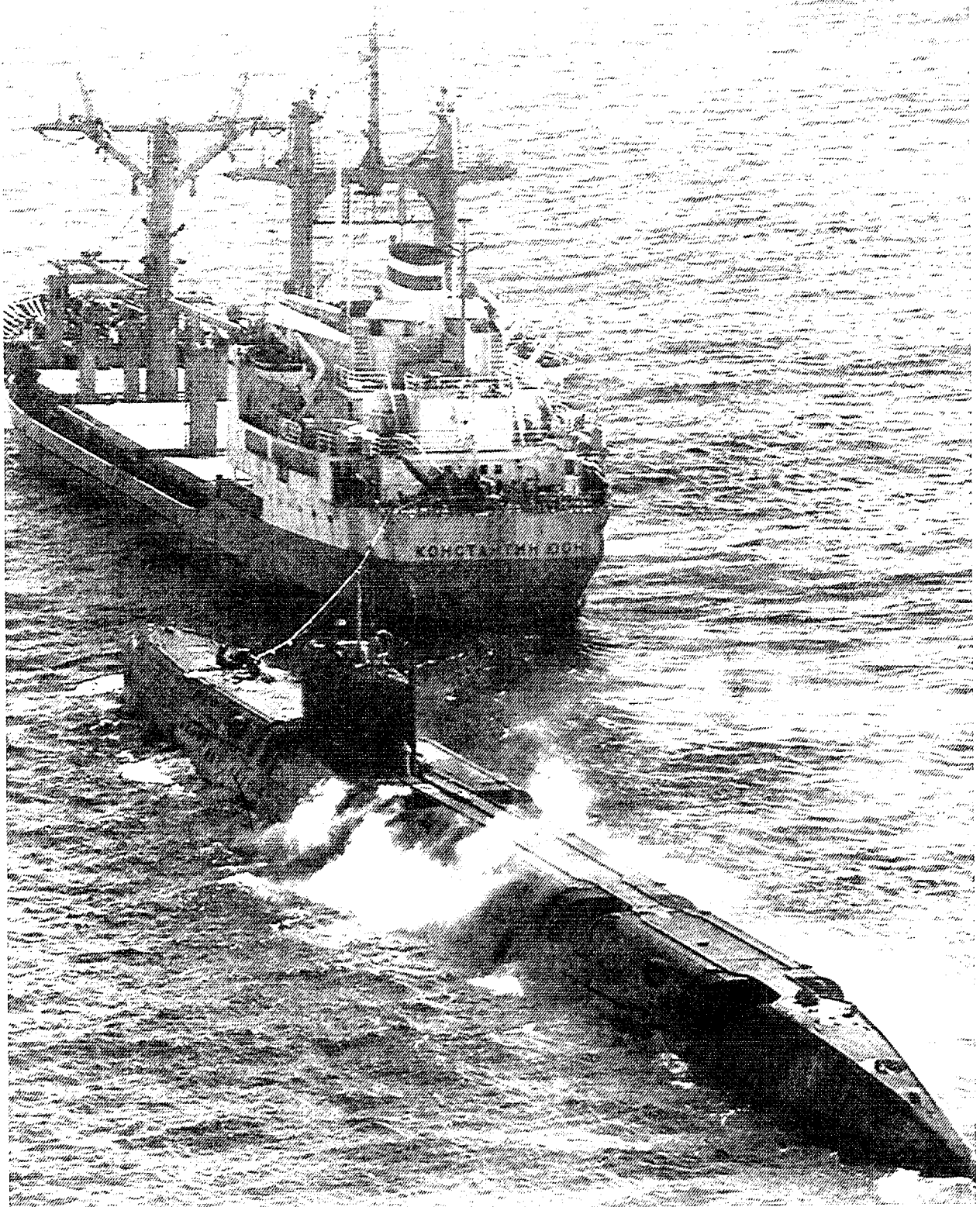

Chapter 8

Nuclear submarine accidents

From 1961 up to the present, there have been a number of accidents and incidents involving Soviet/Russian nuclear submarines. At least 507 people have died in accidents on submarines throughout this period.⁵⁶⁷ The most serious accidents have been caused by fires that have resulted in the sinking of the submarine, or by severe damage to the nuclear reactor following overheating of the reactor core (loss of coolant accidents) and a number of smaller incidents in which radioactivity has been released. Most of the vessels affected by accidents have belonged to the Russian Northern Fleet. This chapter discusses only those accidents that have resulted in the loss of life and/or in releases of radioactivity.

There have also been a number of other incidents in which Northern Fleet submarines have been involved. These include collisions with other submarines, fires at naval bases and shipyards, submarines that have become entangled in trawler nets, accidents during test launches of submarine launched missiles, collisions with icebergs and so forth.⁵⁶⁸

8.1 Sunken nuclear submarines

As a consequence of either accident or extensive damage, there are six nuclear submarines that now lie on the ocean floor: two American vessels (*USS Treasure* and *USS Scorpion*) and four Soviet (K-8, K-219, K-278 *Komsomolets* and K-27). The two American submarines and three of the Soviet nuclear submarines sank as a result of accident; the fourth Soviet vessel was scuttled in the Kara Sea upon the decision of responsible authorities when repair was deemed impossible and decommissioning too expensive. All four of the Soviet submarines belonged to the Northern Fleet.⁵⁶⁹

Despite the differences in time and in location, the Soviet submarine accidents all followed a similar pattern:⁵⁷⁰

1. Fire while submerged on return from patrol.
2. Surfacing of the submarine. Attempts made to salvage the submarine, both in submerged and surface position. By the time of surfacing, vessel had already lost power and possibility for outside contact.
3. Penetration of outside water into the vessel.
4. Command post loss of control over submarine's essential systems.
5. Loss of buoyancy and stability of pitch.
6. Capsize and sinking.

It was not always an accident involving the nuclear reactor that caused these submarines to sink. On all of the Soviet vessels that have sunk, the reactor's shutdown mechanism had been engaged. For extra security, the control rods were lowered manually to their lowest position, an operation entailing such great risk of radiation that it presented a real threat to life.⁵⁷¹

There have been a number of incidents involving naval nuclear reactors of the Northern Fleet that have had serious consequences. Among them are accidents that have resulted in the deaths or overexposure to radiation of the crew, as well as extensive damage to the submarine. The damage was expensive and difficult to repair; and in some instances, the damage to the vessel was so comprehensive that future use was impossible.

The three most serious accidents involving Soviet nuclear submarines are described below. The two American submarine wrecks are discussed in the Appendix.

8.1.1 K-8

The first accident involving a Soviet nuclear submarine involved the Project 627 A - November class vessel K-8, which sank in the Bay of Biscaya on April 8, 1970

567 Handler, J., *Radioactive waste situation in the Russian Pacific Fleet, nuclear waste disposal problems, submarine decommissioning, submarine safety, and security of naval fuel*, October 27, 1994.

568 An overview of accidents and incidents involving Russian nuclear and diesel submarines is given in; Ølgaard, P.L., *Nuclear ship accidents description and analysis*, March 1993; Nilsen, T., and Böhmer, N., *Sources of Radioactive Contamination in Murmansk and Arkhangelsk Counties*, Bellona Report no.1 :1994; Handler, J., *Radioactive waste situation in the Russian Pacific Fleet, nuclear waste disposal problems, submarine decommissioning, submarine safety, and security of naval fuel*, October 27, 1994.

569 *Nezavisimaya Gazeta*, September 10, 1994.

570 Mormul, N., Note, 1995.

571 *Ibid.*

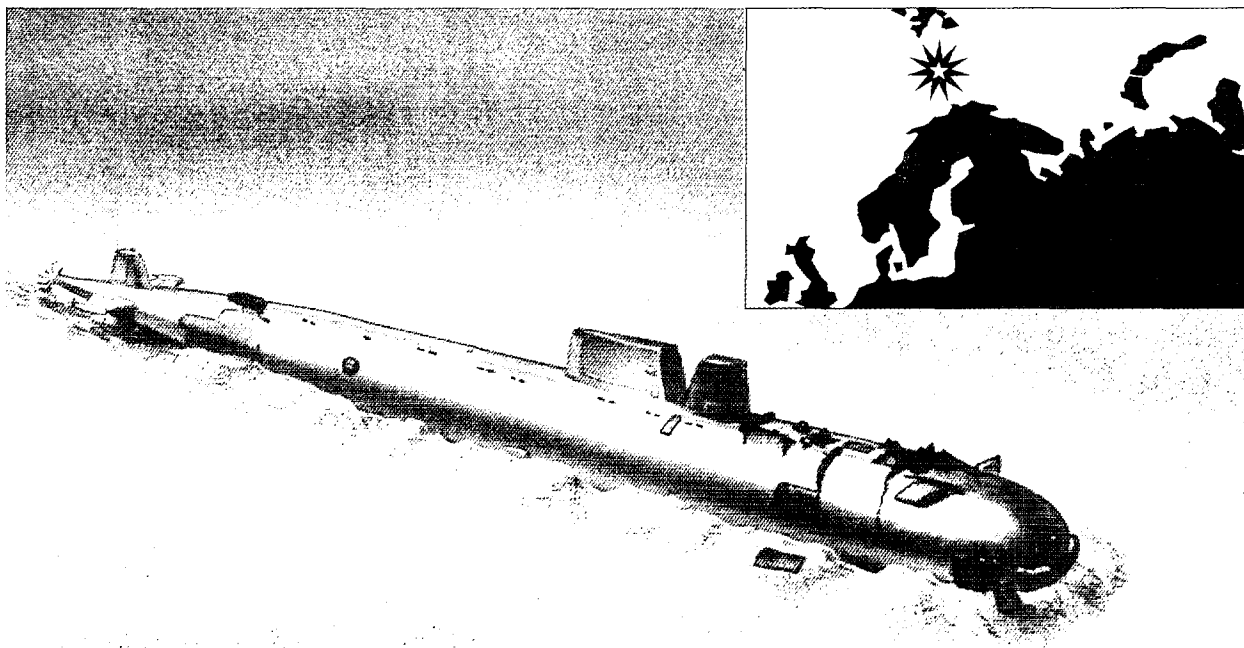

The nuclear submarine *Komsomolets* sank in the Norwegian Sea on April 7, 1989, south of Bear Island. The submarine sank with its reactor and two nuclear warheads on board, and lies at a depth of 1 685 metres.

while returning from the exercise *OKEAN*. Two fires started simultaneously in both the third (central) and eighth compartments. The submarine surfaced, but the crew was unable to extinguish the fires. The reactor emergency systems kicked in, leaving the submarine with virtually no power. The auxiliary diesel generators could not be started either. The control room and all the neighbouring compartments were filled with fumes from the fire. Air was pumped into the aft most main ballast tanks in an attempt to keep the vessel afloat. By April 10, the air tanks had been emptied, and water began to flow into the seventh and eighth compartments. On the evening of April 10, part of the crew was evacuated to an escorting ship. On the morning of April 11 at 06:20, the submarine sank at a depth of 4 680 metres following a loss of stability in pitch. Fifty two people died, including the captain of the vessel. Details of this accident were kept secret until 1991.⁵⁷²

8.1.2 K-219

In October 1986, the strategic nuclear submarine K-219 (Project 667 A - Yankee class) sank in the Atlantic ocean north of Bermuda with ballistic missiles on board after an explosion in one of the missile tubes. The explosion caused a leak in the fourth compartment (missile compartment). Steam and smoke from the missile fuel began to stream out of the damaged missile tube. At the time of the explosion, only one of the vessel's two reactors was running. The submarine surfaced and the

other reactor was started up. Despite the fact that water was beginning to come in, a fire broke out in the fourth compartment. A short in the electrical system tripped off one of the submarine's emergency systems. One life was lost in the struggle to lower the control rods. Though still in a surfaced position, the buoyancy of the submarine was steadily impaired when water filled the main ballast tank. When the second reactor broke down, the crew was transferred to a rescue vessel. The captain and nine crew members remained in the conning tower, but when the bow began to sink, they were obliged to abandon ship. On October 6, at 11:03, the submarine sank with a loss of four lives.⁵⁷³

The reason for the explosion in the missile tube is unclear. There are two theories of how the accident happened: a defect in the missile tube itself or a fire that broke out following a collision with an American submarine.⁵⁷⁴ The submarine had two nuclear reactors and carried 16 nuclear missiles.⁵⁷⁵

8.1.3 K-278 (*Komsomolets*)

In April, 1989, the nuclear submarine K-278, *Komsomolets*, (Project 685 - Mike class) sank in the Norwegian Sea following a fire. *Komsomolets* was a unique titanium-hulled submarine that could dive to depths of 1 000 metres. On the morning of April 7, 1989, the vessel was on the way back to her base at Zapadnaya Litsa, positioned at a depth of 160 m approximately 180 km south of Bear Island. At 11:03 the alarm sounded due to

572 Osipenko, L., Zhiltsov, L., and Mormul, N., *Atomnaya Podvodnaya Epopeya*, 1994.

573 *Morskoy sbornik*, No. 10, 1992.

574 *Ibid.*

575 UPI, *Russian nuclear sub could be an environmental time bomb*, New York, February 8, 1994.

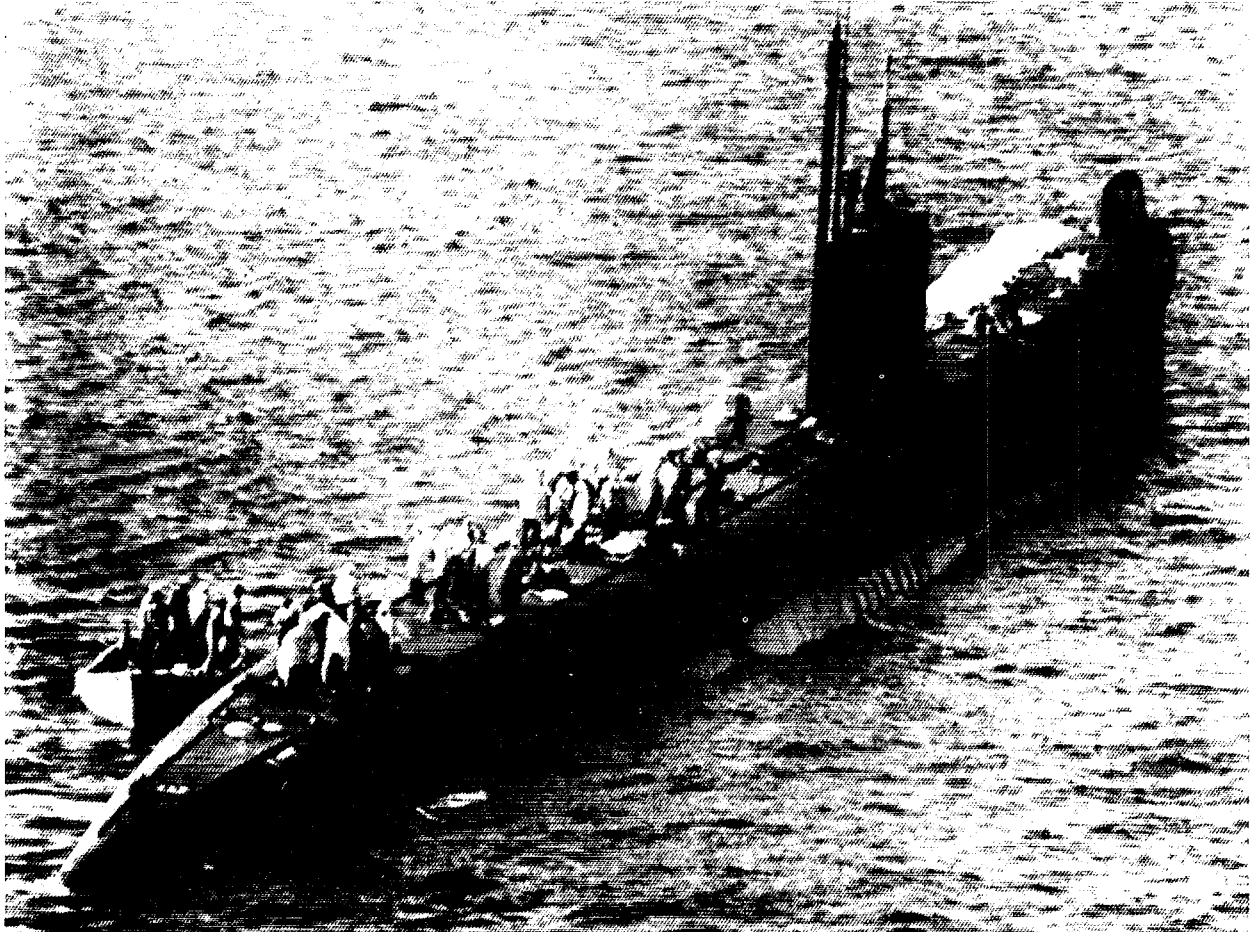

This is one of the Pacific Fleet's Echo-I class nuclear submarines. This vessel suffered a leak of radioactivity following a fire while it lay off the coast of Japan on August 21, 1980. The crew on deck have put on protective clothing against the radioactive gasses from the reactor compartment. Nine crew members died in the fire and three others were injured.

a fire in the seventh compartment. Eleven minutes after the fire had broken out, the vessel surfaced. However, the fire had caused short circuits in the electrical system which set off the reactor's emergency systems. The fire was so fierce that a leak was sprung in the compressed air system, and this led in turn to a spreading of the fire. Attempts by the crew to extinguish the flames were futile. The submarine lost power, and finally ran out of compressed air. By 17:00, the leak had worsened, and the submarine lost buoyancy and stability. The crew began to be evacuated into life rafts, but there were not enough rafts. The life rafts that were lowered were too far away for the crew to reach. At 17:08, the submarine sank at a depth of 1685 meters, with a loss of 41 lives and her commander. The ship *Aleksandr Khlobystov* which came to the rescue after 81 minutes took aboard 25 survivors and 5 fatalities. The exact cause of the fire is unknown. One speculation is that the concentration of oxygen in the seventh compartment was too high, setting off short circuits in the electrical system.⁵⁷⁶

It has also been asserted that shortly before the accident, the vessel had completed a test that indicated it

was not seaworthy.⁵⁷⁷ Others claim that K-278's crew was not qualified to serve on the *Komsomolets*.⁵⁷⁸

8.2 Reactor Accidents

The most serious accident in which radioactivity is released is the meltdown of the reactor core on board the submarine. This is called a nuclear accident. There have been a number of both major and more minor incidents involving naval reactors. These accidents can be grouped into two categories according to the degree of severity:

1. Nuclear accidents;
2. Reactor accidents.

8.2.1 Nuclear accidents

Nuclear accidents are classified either as "loss of con-

⁵⁷⁶ Romanov, D.A., *The Tragedy of the Nuclear Submarine "Komsomolets"*, 1995.

⁵⁷⁷ Conversations with some of the survivors from the *Komsomolets* accident, St. Petersburg, February 22, 1992.

⁵⁷⁸ Information given by Vice Admiral Chernov, St. Petersburg Press, March 12, 1995.

tol" (loss of regulation) accidents in which an uncontrolled chain reaction may occur, or as "loss of coolant accidents". There have been ten nuclear accidents in the entire period that Soviet nuclear submarines have been in operation, one of which occurred in 1970 during the construction of K-329, a vessel of the Charlie-I class. There were two incidents during refuelling operations on K-11 and K-431, another during repairs of a naval reactor at the shipyard (K-140), one during modifications of the submarine (K-222), four during operations at sea, and one during reactor shut down (K-314). Two of the accidents occurred on Pacific Fleet submarines, seven at the Northern Fleet, and one at the shipbuilding yard in Nizhny Novogorod.⁵⁷⁹

K-19

The first nuclear accident to occur on a Russian submarine was on the Northern Fleet's ballistic missile submarine K-19 (Project 658 - Hotel class). On July 4, 1961, during exercises in the North Atlantic, a leak developed in an inaccessible part of the submarine K-19's primary cooling circuit. The leak was specifically located to a pipe regulating the pressure within the primary cooling circuit. The leak caused a sudden drop in pressure, setting off the reactor emergency systems.⁵⁸⁰

To prevent overheating of the reactor, superfluous heat must be removed, and this is done by continually circulating coolant through the reactor. There was no built-in system for supplying coolant to the primary circuit, and it was feared that an uncontrolled chain reaction might start. An improvised system to supply coolant to the reactor was devised. This required officers and midshipmen to work for extended periods under radioactive conditions in the more remote areas of the reactor compartment as they attended to the leak in the primary circuit.⁵⁸¹ The radiation in this case came from noxious gases and steam. All of the crew were exposed to substantial doses of radiation, and eight men died of acute radiation sickness after having undergone doses of 50 to 60 Sv (5 000 - 6 000 rem). The crew was evacuated to a diesel submarine, and K-19 was towed home to base on the Kola Peninsula.⁵⁸²

K-11

The second nuclear accident to occur was in February 1965 aboard the Project 627 - November class subma-

rine K-11. The submarine lay in dock at the naval yard in Severodvinsk and work was underway to remove the reactor core (Operation No. 1). On February 6, the reactor lid was opened, and the following day, the lid was lifted without having first secured the control rods.⁵⁸³ Releases of radioactive steam were detected with an abrupt deterioration of conditions. Radiation monitors were going off scale, and all personnel were withdrawn. No work was done on the submarine over the course of the next five days while the specialists tried to discover the reason for the problem. The wrong conclusions were drawn, and the raising of the reactor lid was attempted again on February 12. Once again, the control rods had not been secured, and when the reactor lid was raised, there were releases of steam and a fire broke out. There are no data on radioactive contamination levels or radiation exposure of the personnel. The reactor was finally retired and replaced.⁵⁸⁴

K-27

On May 24, 1968, the nuclear submarine K-27 (Project 645) was out at sea. During sea trials, the nuclear reactor had operated at reduced power, and on May 24, power inexplicably suddenly dropped. Attempts by the crew to restore power levels failed. Simultaneously, gamma radiation in the reactor compartment increased to 150 R/h. Radioactive gases were released to the reactor compartment from the safety buffer tank, and radiation on board the submarine increased. The reactor was shut down, and approximately 20% of the fuel assemblies were damaged. The incident was caused by problems in the cooling of the reactor core.⁵⁸⁵ The entire submarine was scuttled in the Kara Sea in 1981.⁵⁸⁶

K-140

In August 1968, the Project 667 A - Yankee class nuclear submarine K-140 was in the naval yard at Severodvinsk for repairs. On August 27, an uncontrolled increase of the reactor's power occurred following work to upgrade the vessel. One of the reactors started up automatically when the control rods were raised to a higher position. Power increased to 18 times its normal amount, while pressure and temperature levels in the reactor increased to four times the normal amount. The automatic start-up of the reactor was caused by the incorrect installation of the control rod electrical cables

579 Handler, J., *Radioactive waste situation in the Russian Pacific Fleet, nuclear waste disposal problems, submarine decommissioning, submarine safety, and security of naval fuel*, October 27, 1994.

580 Ølgaard, P.L., *Nuclear Ship Accidents, Description and Analysis*, March 1993.

581 Cherkashin, N., "Hiroshima" Arose in Broad Daylight: Heroes and Victims on the First Soviet Strategic Cruise Missile Submarine K-19, 1993.

582 *Pravda*, July 1, 1991.

583 Ølgaard, P.L., *Nuclear Ship Accidents, Description and Analysis*, March 1993.

584 Osipenko, L., Zhiltsov, L., and Mormul, N., *Atomnaya Podvodnaya Epopeya*, 1994.

585 *Morskoy sbornik*, No. 8 -, 1993.

586 Yablokov, A. V., *Facts and problems related to radioactive waste disposals in seas adjacent to the territory of the Russian Federation*, Moscow, 1993.

and by operator error. Radiation levels aboard the vessel deteriorated.⁵⁸⁷

K-329

In 1970, while the brand new Project 670 - Charlie class submarine K-329 lay in harbour at the shipbuilding yard Krasnoe Sormovo in Nizhny Novgorod, there was an uncontrolled start up of the ship's reactor. This led to a fire and the release of radioactivity.⁵⁸⁸

K-222

On September 30, 1980, the submarine K-222 was at the factory in Severodvinsk due for a thorough reactor check. During the course of work, the submarine's crew left for lunch leaving the factory personnel on board the vessel. As a result of a breach in the pertinent procedural instructions, power was sent through the safety rod mechanisms without the controls also being engaged. Following a failure in the automatic equipment, there was an uncontrolled raising of the control rods with a subsequent uncontrolled start up of the reactor. As a result of this, the reactor core was damaged.⁵⁸⁹

K-123

On August 8, 1982, while on duty in the Barents Sea, there was a release of liquid metal coolant from the reactor of the Project 705 - Alfa class submarine K-123. The accident was caused by a leak in the steam generator. Approximately two tons of metal alloy leaked into the reactor compartment, irreparably damaging the reactor such that it had to be replaced.⁵⁹⁰ It took nine years to repair the submarine.⁵⁹¹

K-314

On August 10, 1985, the Project 671 - Victor-I class submarine K-314 was at the Chazhma Bay naval yard outside Vladivostok. The reactor went critical during refuelling operations because the control rods had been incorrectly removed when the reactor lid was raised. The ensuing explosion led to the release of large amounts of radioactivity, contaminating an area of 6 km in length on the Shotovo Peninsula and the sea out-

side the naval yard. Ten people working on the refuelling of the vessel died in the accident. The damaged reactor compartment still contains its nuclear fuel.⁵⁹²

K-431

In December 1985, the reactor of the nuclear submarine K-431 (Project 675 - Echo-II class) overheated while the vessel was returning to base outside Vladivostok. It is now laid up at the naval base in Pavlovsk.⁵⁹³

K-192 (formerly K-131)⁵⁹⁴

On June 25, 1989, while on the way back to its base at Gadzhievo on the Kola Peninsula, the Project 675 - Echo-II class submarine K-192 suffered an accident involving one of the two reactors on board. At the time of the accident, the submarine was in the Norwegian Sea, about 100 km north-west of Senja in Troms and approximately 350 km south of Bear Island. A leak was discovered in the primary circuit, and the submarine surfaced immediately. Because of the leak, the levels of coolant in the primary circuit had dropped, and the crew hooked up water from the submarine's fresh water tanks. The reactor was not immediately shut down. The contaminated water from the leak was pumped out into the sea, but there is no information about its activity level. When the vessel's fresh water supplies had been consumed, a hose was connected from the Soviet freighter Konstantin Yuon to maintain a supply of coolant to the reactor. Afterwards, the reactor was shut down, and the submarine ran on its diesel engines around the Finnmark coast towards the Kola Peninsula. The temperature of the coolant was at 150 °C on the morning of June 26, 120 °C the same evening, and 108 °C on June 27.⁵⁹⁵

Releases of radioactive iodine were detected in the areas immediately surrounding the submarine, and sometime later, also at a monitoring post at Vardø in Finnmark.⁵⁹⁶ The Northern Fleet service ship *Amur* also came to the assistance of K-192, and the radioactive contaminated coolant was transferred to *Amur* which had a treatment facility on board for liquid radioactive waste. On June 26, the crew of K-192 made an attempt to close the leak in the pipe from the cooling system, and in order to accomplish this, the supply of coolant from *Amur* was shut off. It is not known how long the

587 Osipenko, L., Zhiltsov, L., and Mormul, N., *Atomnaya Podvodnaya Epopeya*, 1994.

588 Handler, J., *Radioactive waste situation in the Russian Pacific Fleet, nuclear waste disposal problems, submarine decommissioning, submarine safety, and security of naval fuel*, October 27, 1994.

589 Osipenko, L., Zhiltsov, L., and Mormul, N., *Atomnaya Podvodnaya Epopeya*, 1994.

590 *Ibid.*

591 Ølgaard, P.L., *Nuclear Ship Accidents, Description and Analysis*, March 1993.

592 Handler, J., *Radioactive waste situation in the Russian Pacific Fleet, nuclear waste disposal problems, submarine decommissioning, submarine safety, and security of naval fuel*, October 27, 1994.

593 *Ibid.*

594 Unless stated otherwise, the information in this section is from *The Eco-Planet*, No. 40 - 1991, and *Morskoy sbornik*, No. 10,-1992.

595 Osipenko, L., Zhiltsov, L., and Mormul, N., *Atomnaya Podvodnaya Epopeya*, 1994.

596 Backe, S., *The Accident of the Soviet Echo-II Class Submarine, Preparatory Measures, Measurements of Radioactivity, Iodine Releases and Consequences*, November 3, 1989.

coolant supply was shut off; however, the individual in charge of monitoring the coolant supply "forgot" to turn it on again when he left his post to go and eat dinner. This person later claimed that he had not in fact forgotten, but was waiting for orders to turn on the supply again. These orders did not come before dinner.⁵⁹⁷

Due to the loss of coolant, the temperature in the reactor increased and the alarm went. The supply of coolant was immediately switched on again, but too late. The supply of cold coolant led to the cracking of the overheated fuel assemblies, and water came into contact with the uranium fuel. The heavily contaminated water being pumped over to *Amur* led to the breakdown of the treatment plant. Subsequently, water was taken in directly from the sea and pumped out into it again. The total activity and amounts of contaminated water released from K-192 into the sea is not known. At this point, the vessel was positioned in international waters somewhere between the North Cape and the Kola Coast, more than 12 nautical miles off the coast. On June 28, K-192 arrived at the Ara Bay base facility belonging to the naval base at Gadzhievo.⁵⁹⁸ At base the activity of the contaminated coolant was estimated at 0.3 Ci/l, totalling 74 TBq, 2 000 Ci.⁵⁹⁹ The submarine's crew received doses of up to 40 mSv (4 rem).⁶⁰⁰

K-192 was laid up at the base facility in the Ara Bay until 1994 when it was towed to Navy yard No. 10 - Shkval. Compressed air is now pumped into the hull to maintain buoyancy. The fuel assemblies in the damaged reactor cannot be removed by standard procedures.⁶⁰¹ (See Chapter 6 on the decommissioning of nuclear submarines).

K-8

On October 13, 1960, one of the most serious accidents involving a naval reactor occurred on a Northern Fleet vessel. The incident was caused by a loss of coolant to the reactor, and is classified accordingly. The Project 627 - November class submarine K-8 was on exercise in the Barents Sea when a leak developed in the steam generators and in a pipe leading to the compensator reception. The equipment for blocking these leaks was also damaged such that the crew itself began the work of stopping the leak. They mounted a provisional system for supplying water to the reactor to ensure cooling of the reactor and thereby avoid the risk of a core melt in the reactor. Large amounts of radioactive gases leaked out which contaminated the entire vessel. The true acti-

Some SSN nuclear power units failures and accidents causing radiation discharge

K-387	1976	Main condenser breakage (2 persons injured to death)
TK-208	1986/87	Cleaning unit leakage
K-279	1984	Leaky steam generator
K-447	1985	Leaky steam generator
K-508	1984	Leaky steam generator
K-208	1985	Leaky steam generator
K-210	1984	Leaky steam generator
K-216	1984	Leaky steam generator
K-316	1987	Leaky steam generator
K-462	1984/86	Critical underspace leakage of primary circuit
K-38	1984/86	Critical underspace leakage of primary circuit
K-37	1984/86	Critical underspace leakage of primary circuit
K-371	1986	Critical underspace leakage of primary circuit
K-367	1985	Automatic control break

vity of the gases could not be determined because the instrumentation only went to a certain level. Three of the crew suffered visible radiation injuries, and according to radiological experts in Moscow, certain crew members had been exposed to doses of up to 1.8 - 2 Sv (180 - 200 rem).⁶⁰²

8.3 Fires resulting in loss of life

In addition to the accidents involving fires whereby the vessels themselves were lost, there have been four serious accidents involving fires on Northern Fleet nuclear submarines that have resulted in the loss of human life.

K-3

On September 8, 1967, while sailing in the Norwegian Sea on the way home to its base on the Kola Peninsula, a fire broke out on board the nuclear submarine K-3 (Project 627 A - November class). The fire started in the submarine's hydraulic system, and crew members in the compartment when the fire broke out had to evacuate the compartment. This resulted in the flames spreading to other parts of the submarine. The automatic extinguishers were based on CO₂ gas, and this gas killed the

597 Nilsen, T., *The Accident on the Submarine K-192*, August 2, 1995.

598 *Morskoy sbornik*, No. 10,-1992.

599 Yablokov, A. V., *Facts and problems related to radioactive waste disposals in seas adjacent to the territory of the Russian Federation*, Moscow 1993.

600 *Morskoy sbornik*, No. 10,-1992.

601 Shmakov, R.A., Design Bureau Malakhit, presentation of the paper *Problems in Decommissioning Nuclear Submarines and the Protection of the Environment in Arctic regions*, Pp. 29-30, Severodvinsk, March 15 - 16, 1995.

602 Osipenko, L., Zhiltsov, L., and Mormul, N., *Atomnaya Podvodnaya Epopeya*, 1994.

crew members who were in the first and second compartments foremost in the submarine. When the dividing door in the bulkhead from the third compartment was opened to see what had happened to the people in the second compartment, the gas spread, and more people lost consciousness. The foremost compartments were then completely sealed off, and the submarine surfaced. Four days later, K-3 had returned to base. A total of 39 crew members died in the fire.⁶⁰³

K-19

On February 24, 1972, while the vessel was on patrol in the North Atlantic, a fire broke out in the ninth compartment on board the Project 658 - Hotel class submarine K-19. The fire started at 10:23 AM, and the ninth compartment was immediately closed off to prevent the fire from spreading to other parts of the vessel. Twelve crew members in the tenth compartment aft in the submarine were thereby isolated, and were not rescued until March 18, after 24 days of fighting the fire. A total of 28 people died in the fire which was caused by a break in one of the hydraulic pipes. Over 30 ships were involved in the rescue of K-19, and the submarine finally returned to base on the Kola Peninsula on April 4.⁶⁰⁴

Some emergencies on SSNs

K-508	Apr.	1984	Fire
K-38	March	1985	Fire
K-279	Dec.	1986	Fire caused by shot circuitry in electrical equipment
K-255	March	1985	Fire caused by shot circuitry in electrical equipment
K-369	Dec.	1985	Fire
K-239	Dec.	1987	Fire
K-42	Apr.	1984	Fire
K-517	May	1984	Fire
K-192		1985	Oil heater explosion
K-298		1985	Fire
K-503	Jan.	1984	Water penetration into the reactor compartment
K-475		1984	Water penetration into the reactor compartment

K-47

On the 26 of September 1976 when the submarine was in the Barents Sea on its way to the home port fire broke up in the 8-th compartment. 8 crew members died of injuries.

K-131

On June 18, 1984, a fire broke out in the eighth compartment aboard the Project 675 - Echo-II class submarine K-131. This submarine too was returning to base on the Kola Peninsula. The cause of the accident was that the clothes of one of the crew members caught fire while he was working on some electrical equipment. The fire spread to the seventh compartment and caused the death of 13 crew members.⁶⁰⁵

8.4

Causes of Accident⁶⁰⁶

The complex "man-machine" system represented in the modern nuclear submarine, increases the risk of accidents. The causes of the various accidents depend to a large extent on both the qualities of the reactor and the situation leading up to the accident.

The existing framework of project development, building and delivery of military technology (navy) and ammunition is not regulated by law, but by decree of defunct authorities, such as the Central Committee of the Communist Party, various councils of Soviet ministers, the military-industrial complex, as well as joint decisions handed down by the Ministry of Ship Building and the Ministry of the Navy. The administrative body of the military industrial complex, led by the vice-chairman of the council of ministers, itself issued the documents that established the norms, and it was this same body that monitored and enforced the norms that it had itself created. The practice of merging the functions of public agencies contributed to the fact that the Navy itself did not take part in working out quality control and safety requirements for nuclear submarines. Even if the Navy politely refused to receive equipment that they knew in advance to be defective, it could nonetheless be forced to accept it through a common resolution issued by the authorities.

This structure of resolutions and decrees has followed the delivery of all new nuclear submarines to the Soviet Navy. Soviet nuclear submarines were built under enormous time constraints. If the Central Committee of the Communist Party had determined that a particular submarine was to be built by the close of a certain year or a particular season, the submarine yards could not postpone delivery, even if the vessel had not been completed or undergone sea trials. Hence nuclear submarines were often delivered to the Navy without all the necessary safety equipment having been installed. Furthermore, the procedural guidelines and the specifi-

⁶⁰³ Ibid.

⁶⁰⁴ Ølgaard, P.L., *Nuclear Ship Accidents, Description and Analysis*, March 1993.

⁶⁰⁵ Osipenko, L., Zhiltsov, L., and Mormul, N., *Atomnaya Podvodnaya Epopeya*, 1994.

⁶⁰⁶ Unless otherwise stated, the information in this section is taken from *Nezavisimaya Gazeta*, October 10, 1994.

cations of the contract were modified and simplified. It was not uncommon for a nuclear submarine to be delivered to the Navy from the building yard with missing or defective parts. In 1989 there were 529 complaints of nuclear submarines being delivered with faulty equipment. In 1990-91 a new nuclear submarine was returned to the building yard due to numerous defects in the mechanical equipment. Another submarine was delivered without light switches having been installed in the cabins or in the missile compartment.⁶⁰⁷

The servicing and repair of nuclear submarines was carried out at naval yards that fell under the jurisdiction of different authorities. This system was established at the dawning of the age of nuclear submarines and it came to the full during the cold war. Almost 25 nuclear submarine projects were initiated and developed during this period. The lack of sufficient standardisation led to problems in the planning stage, in the competence levels of the crew and in an unavailability of spare parts. The quality and safety of the equipment was compromised, and this has been one of the most important contributing factors to the higher incidence of accidents amongst Soviet nuclear submarines as compared to for example American vessels.

There were also many common factors in the accidents on board Russian nuclear submarines, reflected again and again in the accident statistics:

1. The frequency of accidents was increased as early as the planning stage due to technological deficiencies in a number of areas (information, securing secrets of propulsion and means of carrying out research) and deficiencies in construction. One of the main problems was the poor quality of the metals and materials that were used.
2. At the construction stage, breaches in the technological standards by the builders affected the quality of the finished product such that the finished submarines that were actually delivered to the Navy fell short of the quality of their design. Furthermore, the schedule for delivery of various systems and parts, as well as the order in which operations were completed and breaches in the proper technical procedures, all contributed to lowering the quality of the submarine. The quality of the work was poor due to a lack of technical understanding amongst the workers. In some instances, there was not even enough technical equipment at the navy shipyards and floating bases.
3. During the testing and approval stage, there were interruptions to the schedule due to delays in deliveries and installation of parts and systems. Under outside pressure from concerned parties, the submarines were approved even before the equipment on board had been tested.
4. The frequency of accidents also increased during the

submarines' operational life due to poor maintenance, a disregard of the directions for use and improper procedures for technical equipment and ammunition. The crew were assigned to tasks other than their direct responsibilities, and therefore were lacking in training, especially with regards to measures designed to ensure the survivability of the submarine. At one time, one submarine commander sent in a complaint that eleven of the 28 new members of the crew could not speak Russian and therefore were not qualified to work with the nuclear reactor. Many of the new crew for the nuclear submarines had received only six months training, training that often was insufficient or irrelevant to the situations they might confront on a nuclear submarine.⁶⁰⁸ There was a widespread irresponsible attitude from incompetent outside specialists. The crews were too inexperienced to be able to foresee potential dangers that could lead to critical situations while the submarine was in operation. The search and rescue bases, which have shown a lack of co-ordination in conducting searches, weakened overall preparedness in a number of accidents. The absence of formal conclusions at inquests and a lack of ready information in response to the questions about the nature of the accidents and their frequency resulted in a failure to implement measures to improve the conditions on board the nuclear submarines.

A number of general measures could be implemented to reduce the frequency of accidents, including the following:

- a) Transition and transformation into a professional navy.
- b) Reform of the governing powers in the military industrial complex; division into legislative, executive and administrative functions. Development, production and delivery of ships and military technology regulated by law.

Without implementing these types of reforms, it will be difficult to reduce the frequency of accidents.

There are three main factors contributing to the safe operation and use of nuclear submarines:

1. The quality of the design and construction of the vessel, its ammunition and technical equipment;
2. Skill in the operation of nuclear submarines and in the use of pertinent technology over the course of the vessel's operational lifetime;
3. Professional training of the crew and professional administration of work on nuclear submarines.

Russia continues to lead the world in the field of submerged speed and deep-diving submarines. The shipbuilding industry in the former Soviet Union expended considerable resources and employed experienced and highly skilled personnel to build its submarines. This made it possible to build submarines at a rapid pace; however,

607 Handler, J., *Submarine Safety - The Soviet/Russian Record*, Jane's Intelligence Review, July 1992.

608 Ibid.

there were hardly any vessels, submarines or surface vessels, that were delivered to the Navy free of flaws. The deficiencies were often serious. As a rule, nuclear submarines were delivered from the shipbuilding yards at the end of the year. Regardless of the circumstances, the shipbuilding yard had to guarantee that the vessel would be delivered no later than December 31. Tremendous pressure was put on the chairman of the State Committee for Approval from the whole hierarchy of the Ministry of Shipping and Industry, and strange though it may seem, he was also pressured by the Chief Commander of the Navy. The chairman faced a choice between telling the truth about the condition of the submarines - and thereby lose his job - or else avoiding the question. The latter course of action was invariably chosen.

Regardless of incompleteness or missing parts, nuclear submarines were delivered to the Navy as long as they were capable of operating under their own steam. Every so often, a submarine might remain at the building yard until it was capable of operating independently. A special contract was established entitled *Joint Decisions of the Ministry of Shipping and the Navy*, where the building yards promised to improve or amend faults and deficiencies within a certain period of time. The Navy also agreed to this.

Any submarine that formally entered service with the Navy could be assigned to any kind of assignment or mission within the Navy's sphere of operation, including battle. However, there was no sense of concern or organised plan for conditions of storm or chaos; nor were there any preparations made for such emergencies. It was precisely here that accidents could happen. A serious consequence of this lack of concern was its unfortu-

nate effect on the attitude of the crew - rather than feeling a sense of responsibility themselves, they simply signed on for duty on incomplete nuclear submarines and hoped for the best.

The day-to-day running of a nuclear submarine involves a whole series of routine procedures and operations, ranging from weekly monitoring and overhaul to varying and more extensive service procedures at the shipyard. The execution of such work requires a sufficient number of naval yards and repair shops, as well as spare parts and operative materiel. The bulk of the Northern Fleet's resources was allocated to the development and construction of its main components: ships and ammunition. The rest received what was left - but this was very little. By the end of the 1980s, the Soviet Union had more nuclear and diesel submarines than all the other nations of the world combined. Yet Russia's submarines barely achieved half of the American operational life. The useful life of the Russian submarine was shortened by the limited possibilities for repair and an underdeveloped industry.

The division of labour aboard the nuclear submarines could also have been better. Today, the vessel's commanding officer has total responsibility. He is also liable for mistakes made by his subordinates, even when it is apparent that another individual's poor judgement has caused the error. The problem is that the commanding officer seldom has the opportunity to discharge this responsibility. Furthermore, the crew of submarines, especially officers, work under conditions of constant physical and psychological overload, with irregular working hours and rest periods.

Appendix

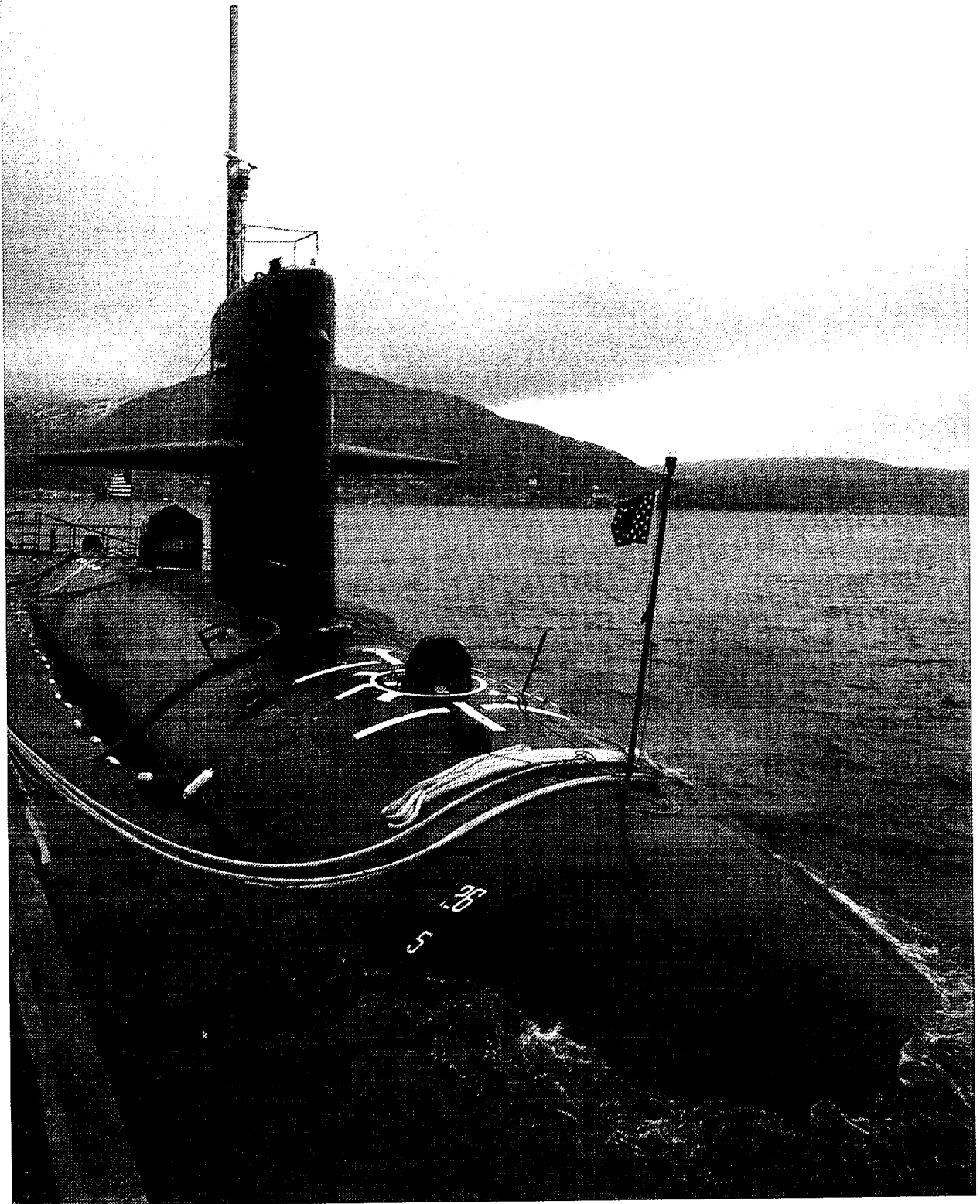

Appendix

Excluding Russia, there are at this time four countries with nuclear submarines in service: the United States, the United Kingdom, France and China. These four nations have a total of 133 nuclear submarines in operation. The USA and the Soviet Union/Russia have been the leading countries in developing new nuclear submarines. In the aftermath of the second World War it became obvious that the limiting factor in the further development of the submarine was the matter of fuel. Efforts were therefore focused on developing an alternative to the existing source of power, the diesel engine.

1. USA

In 1949, the United States Navy began to explore the possibility of utilising nuclear power in its submarines. Development work was headed by then Captain, now Admiral Rickover, and corporations such as Westinghouse, General Electric, Combustion Engineering and Babcock & Wilcox were important players in the process. To find the optimal reactor for use on board a submarine, full-scale test models of the different types of reactors were built on land.⁶⁰⁹

1.1

Attack submarines, SSN

The construction of the world's first nuclear submarine, *USS Nautilus*, began in the early 1950's. The *USS Nautilus* (SSN 571) was launched in 1954, and in 1957, was the first submarine to sail beneath the polar ice. The prototype was powered by a pressurised water reactor (type S2W) yielding 70 MWt⁶¹⁰ and transferring 7 500 shp⁶¹¹ to each of the two propellers.⁶¹² *USS Nautilus* was followed by a second prototype, the *USS Seawolf* (SSN 575) which was equipped with a sodium cooled reactor. This reactor was designed to perform more effi-

ciently within a smaller volume, but it turned out to be difficult to utilise. The reactor was later replaced by a pressurised water reactor.⁶¹³

Based on the construction of *USS Nautilus*, a fleet of four Skate-class submarines were launched, offering the opportunity to experiment with different technologies. The first submarine of this class, the *USS Skate* (SSN 578), was the first submarine to surface at the North Pole.⁶¹⁴ The Skate class submarines were equipped with one pressurised water reactor, type S3W, giving a thermal power of 70 MWt. In this period (late 1950s), several different prototypes and reactor types were tested.⁶¹⁵

The Skipjack class was the next class to be developed. The submarine hulls in this class were shaped like a tear drop, the so-called Albacore-shape. The shape of the hull, along with a type S5W pressurised water reactor with a thermal power of 70 MWt delivering 15.000 shp to the propellers,⁶¹⁶ combined allowed the submarine to travel at speeds exceeding 30 knots. The Skipjack class vessels were the fastest submarines of the period.⁶¹⁷

Until the 1970s, the United States Navy predominantly used the S5W reactor. It yielded thermal power of 70 MWt, and was equipped with double steam generators, turbines and turbo generators.⁶¹⁸

The next step was to develop submarines for the purpose of anti-submarine warfare, and to this end, the silent prototype *USS Tullibee* (SSN 597) was built. The prototype was fitted with a small reactor generating a

609 Eriksen, V.O., *Sunken Nuclear Submarines*, 1990; and Clancy, T., *Submarine*, 1993.

610 Thermal power

611 Shaft Horse Power

612 Eriksen, V.O., *Sunken Nuclear Submarines*, 1990.

613 Clancy, T., *Submarine*, 1993.

614 Ibid.

615 Eriksen, V.O., *Sunken Nuclear Submarines*, 1990.

616 Ibid.

617 Clancy, T., *Submarine*, 1993.

618 Eriksen, V.O., *Sunken Nuclear Submarines*, 1990.

power of 20 MWt and 2 500 shp.⁶¹⁹ There were considerable technical problems with this submarine, and the prototype was the only one built. However, the more successful technical aspects from the *Tullibee* project were used in later submarines.⁶²⁰

Following the *USS Tullibee* came a new class of silent and deep diving attack submarines, the Permit class. The first submarine in this class was the *USS Treasure* (SSN 593), equipped with the proven S5W reactor. The pressurised hull was made of HY80 steel, and the submarine had a maximum diving depth of 400 meters.⁶²¹ The submarine sank during a diving test on April 10, 1963, and all the crew were lost. The loss of *Treasure* led to modifications in the construction of this class of submarines. The next vessel was a modified version, the *USS Permit* (SSN 594), from which this class of submarines takes its name.⁶²²

The Permit class of attack submarines was followed by the Sturgeon class, which also used the S5W reactor.⁶²³ The noise from these submarines was reduced in comparison to the Permit-submarines, but its top speed was only about 25 knots. Its maximum diving depth was 400 meters. There was a total of 37 submarines in this class.⁶²⁴

In 1976, the *USS Los Angeles* (SSN 688) was completed. She was the first of approximately 60 submarines in the silent Los Angeles-class. The class is equipped with a type S6G pressurised water reactor yielding 120 MWt, or 30 000 shp. This reactor is a modified version of the D2G-reactor used in nuclear destroyers from the early 1960s.⁶²⁵ With this reactor, the submarine has a submerged maximum speed of 32 knots.⁶²⁶ The increased maximum speed compared to the Permit/Sturgeon, led to a reduced maximum diving depth of 300 meters due to its thinner hull.⁶²⁷

1.2.

Ballistic missile submarines, SSBN

The first nuclear powered ballistic missile submarine (SSBN) to be built in the United States, was the *USS George Washington* (SSBN 598), which for the most part was a modified Skipjack-submarine. The hull was exten-

ded to accommodate 16 Polaris missiles. The first launch test was near Cape Canaveral, Florida, on July 20, 1960. A total of five submarines was built in this class. There were also five submarines in the Ethan Allen-class which was specifically designed to carry the Polaris missiles. These vessels were larger and quieter than their predecessors in the George Washington-class.⁶²⁸

In the succeeding class, the missile tubes were expanded to accommodate the newly developed Polaris A3 missiles, and the class would later also carry the Poseidon C3 and the Trident C4. The technology used in making the Permit class so silent was also installed. The first submarine in this class was the *USS Lafayette* (SSBN 616), from which the class takes its name.⁶²⁹ A total of nine Lafayette class submarines were built.⁶³⁰

The fourth generation of SSBN submarines was the Ohio-class, built to run as silently as possible. With a length of 170.7 meters and a displacement 18 750 tons, this is the largest submarine in the United States Navy. Originally, the class was to be powered with the same reactor as the Lafayette-class, the S5W-reactor, but the type S8G reactor was selected instead. This is a silent operating reactor with power of 220 MWt and 60 000 shp. The coolant circulates through natural convection.⁶³¹

All submarines in this class are equipped with 24 Trident C-4 or Trident-II D-5 missiles. Plans originally called for 20 submarines in this class, but due to the START II-agreement, only 18 were built.⁶³²

1.3.

Accidents

During a diving test on April 10, 1963, after a nine months maintenance period, the *USS Treasure* sank approximately 160 km east of Cape Cod, at 41:43'N, 64:57'W. The accident was probably caused by a water leak in the pipes in the engine room, preventing the submarine from rising to the surface.

The submarine was crushed by the water pressure, and is now lying in six pieces at a depth of 2 600 meters. The entire crew of 129 was lost. There have been no attempts to raise parts of the submarine, but samples

619 Ibid.

620 Clancy, T., *Submarine*, 1993.

621 Eriksen, V.O., *Sunken Nuclear Submarines*, 1990.

622 Clancy, T., *Submarine*, 1993.

623 Eriksen, V.O. *Sunken Nuclear Submarines*, 1990.

624 Clancy, T., *Submarine*, 1993.

625 Eriksen, V.O., *Sunken Nuclear Submarines*, 1990.

626 Jane's Fighting Ships, *Recognition Handbook*, 1994.

627 Clancy, T., *Submarine*, 1993.

628 Ibid.

629 Ibid.

630 Toppan, A., *USN Submarine List*, URL: <http://www.wpi.edu/~elmer/>, 1995

631 Eriksen, V.O., *Sunken nuclear submarines*, 1990.

632 Clancy, T., *Submarine*, 1993.

have been taken to check for leaks of radioactivity in the area. The samples indicate low concentrations of radioactivity in the sediments (12 Bq/kg ^{60}Co).⁶³³

The Skipjack class submarine, *USS Scorpion*, sank May 22, 1968 approximately 650 kilometres south-west of the Azores while heading from Gibraltar to Norfolk, Virginia. It sank at a depth of 3 600 meters. The submarine was torn into two pieces, and there are speculations that the accident may have been caused by the explosion on board of one of the torpedoes. *USS Scorpion's* crew of 99 were all lost. In addition to the nuclear reactor, there were also two torpedoes with nuclear warheads

onboard. Samples taken in the area indicate low levels of radioactive contamination in the sediments.⁶³⁴

Development and research on nuclear submarines in the United Kingdom began in 1954. A land-based prototype reactor, called the DS/MP, was completed at Dounreay in Scotland in 1963. The United Kingdom has co-operated closely with the United States, and the first nuclear submarine of the Royal Navy was fitted with an American type S5W pressurised water reactor. The reactor was installed in the submarine *HMS Dreadnought* launched in 1963.⁶³⁵ This submarine closely resembles the American Skipjack class.⁶³⁶

2. United Kingdom

2.1

Attack submarines

The operation of the DS/MP reactor in Dounreay and experiences with the S5W reactor led to the development of the first generation of British pressurised water naval reactors, the PWR-1, with a thermal power of 70 MWt, and 15 000 shp. This reactor was installed in the first generation of British nuclear submarines, the Valiant class, with the first being installed in *HMS Valiant*, from which the class takes its name.

The second generation of the PWR-1 reactor was installed in the Swiftsure-class, which went into service in 1973.⁶³⁷ This class of submarines had a speed of just over 30 knots. At this time, there are five submarines of this class in operation.⁶³⁸

A third generation of the PWR-1 reactor was developed to prolong the operational life of the reactor core. This reactor was installed in the Trafalgar class, which began service in the late 1970s. Much effort was expended in reducing the noise of the submarine.⁶³⁹ The Trafalgar class has a maximum speed of 32 knots,⁶⁴⁰ and at present, there are seven vessels in active service.

2.2

Ballistic missile submarines

Based on the Valiant class, the Resolution class of submarines was developed in order to accommodate the Polaris ballistic missiles. The class was fitted with first generation PWR-1 naval reactors. The Royal Navy ordered four submarines of this type in 1963.⁶⁴¹

In 1976, a new type of reactor was ordered so as to increase safety margins, ease inspection while in operation, and improve the power output. A land based prototype, the STF2, was built at Dounreay, and on this basis, a new reactor type, the PWR-2, was developed yielding a thermal power of 130 MWt and 27 500 shp. This reactor was used for the first time on board a vessel of the Vanguard class, which is slated to replace the Resolution class of submarines. Vanguard class submarines are equipped with Trident missiles.⁶⁴²

633 Ølgaard, P.L., 1994.

634 Ibid.

635 Eriksen, V.O., *Sunken nuclear submarines*, 1990.

636 Preston, A., 1980.

637 Ibid.

638 Jane's Fighting Ships, Recognition Handbook, 1994.

639 Eriksen, V.O., *Sunken nuclear submarines*, 1990.

640 Jane's Fighting Ships, Recognition Handbook, 1994.

641 Eriksen, V.O., *Sunken nuclear submarines*, 1990.

642 Ibid.

3. France

Contrary to other countries which first of all developed nuclear powered attack submarines, the first efforts of France were directed into the building of a ballistic missile submarine. The French programme began in 1959. By 1964, there was a land-based prototype reactor ready at Cadarache in southern France. A reactor based on the prototype was installed in the first of the Le Redoutable class of ballistic missile submarines. Launched in 1969, the *Le Redoutable* generated 16 000 shp with a top speed (submerged) of 25 knots. A total of six submarines of this class were built until 1984. The Le Redoutable class was followed by the Le Triomphant class which is powered by a type K15 reactor yielding thermal power of 150 MWt and 41 500 shp.⁶⁴³

The first class of French nuclear powered attack submarines was equipped with second generation reactors. The first submarine in this class was Le Rubis, from whence the class gets its name. With a length of 72.1 meters and a displacement of 2 670 tons, this is the world's smallest nuclear powered submarine.⁶⁴⁴ The submarines in the Le Rubis class have a top speed of 25 knots. At present, there are 6 operational submarines in this class, including *Amethyste* and *Perle* which are somewhat longer and of an improved design.⁶⁴⁵

4. China

China has a total of six operational nuclear submarines, five attack submarines and one ballistic missile submarine. The five attack submarines are of the Han class, and are fitted with a pressurised water reactor yielding 15 000 shp. These submarines are quite noisy, and have a maximum speed of 30 knots. China's only ballistic missile submarine is of the Xia class, and is comparable to the Russian Yankee-II submarine. The Xia class submarine utilises the same type of reactor as the Han-submarine, and has a maximum speed of 20 knots.⁶⁴⁶

5. India

India is developing a nuclear powered submarine, most probably an attack submarine. The naval reactor for this submarine is being developed in co-operation with Russia.⁶⁴⁷

Table 11. Countries outside Russia with operational nuclear submarines⁶⁴⁸

	Attack submarines		Ballistic missile submarines	
	SSN	SSBN	SSN	SSBN
	Class	Number	Class	Number
United States	<i>Los Angeles</i>	58 (3)	Ohio	16 (2)
	Sturgeon	23		
	Permit	1		
	Narwhal	1		
	Special operations	2		
United Kingdom	Valiant		Resolution	2
	Swiftsure	5	Vanguard	1 (3)
	Trafalgar	7		
France	Le Rubis	6	Le Redoutable	5
China	Han	5	Xia	1
Total		108		25

643 *Ibid.*

644 Clancy, T., *Submarine* 1993.

645 Jane's Fighting Ships, Recognition Handbook, 1994.

646 Clancy, T., *Submarine*, 1993.

647 Jane's, *Jane's Fighting Ships*, 1994.

648 International Institute for Strategic Studies, 1995.

References

- Aftenposten*, Ukjent atomulykke i nord (Unknown nuclear accident in the north), Oslo March 13 1993.
- Aleshin, V. S., *Vessel Nuclear Reactors*.
- Atomnaya Energiya*, Moscow, No. 1 and 3 1992, No. 4 1993, No. 2, 4, 5 and 6 1994.
- Backe, S., *Havari av sovjetisk ubåt, Echo-II, Beredskapstiltak, radioaktivitetmålinger, utslipp av jod og konsekvenser* (The loss of a Soviet Echo II submarine, preparedness, radiation monitoring, release of radioactive iodine and consequences), National Institute of radiation Hygiene (new name 1993 "Norwegian Radiation Protection Authority"), Østerås 3 November 1989.
- Bakhmetyev, A. M., *Methods of judging safety levels and securing nuclear energy generators*, 1992.
- Barents News*, Kirkenes, 1995.
- Berlin, J., Kondratyeva, V., Musorin, E., Nevriev, J. and Shiriaev, A., *The Flying Dogs Island*, unpublished article, 1993.
- Bukharin, Oleg and Handler, Joshua, *Russian Nuclear Powered Submarine Decommissioning*, Science & Global Security, No. 5 pp. 245 - 271, Amsterdam 1995.
- Bøhmer, Nils and Nilsen, Thomas, *Reprocessing Plants in Siberia*, Bellona Working Paper No. 4, Oslo 1995.
- Castberg, Rune, Note, The Fridtjof Nansen Institute, Lysaker 1995.
- Cherkashin, Nicolay, «Hiroshima» appeared at High Noon, Heroes and Victims of the first Soviet Strategic Cruiser-Missile Submarine K-19, Logbook in the Series Shipwreck Alarm, Moscow 1993.
- Clancy, Tom, *Submarine, A guided tour inside a nuclear warship*, New York 1993.
- Decommissioning obsolete submarines and storing reactor compartments*. Paper presented at conference on *Problems in decommissioning and dismantling of nuclear submarines*, Moscow, June 19-22 1995.
- Document from the local *Gosatomnadzor* (V. Dimitriev), Severodvinsk Environmental Committee (M. Mailov) and the Control Committee for objects subject to the Ministry of Defence (A. Gordienko), Severodvinsk 1995.
- "Eco-planet" No. 40 - 1991.
- Eriksen, Viking Olver, *Kjernevåpen - hva nå?* (Nuclear weapons-what now?), Kjeller 1995.
- Eriksen, Viking Olver, *Sunken Nuclear Submarines*, Oslo 1992.
- Faulkner, Keith, *Jane's Fighting Ships, Recognition Handbook*, Surrey 1994.
- Goriyledzyan, E. A., Shmakov, R. A., Shukharov, F. N. and Steblin, P. G., Lectures presented in the document: *Problems of decommissioning of nuclear powered submarines and environmental protection in Northern areas*, Severodvinsk March 15 - 16, 1995.
- Handler, Joshua, *Radioactive Waste Situation in the Russian Pacific Fleet, Nuclear Waste Disposal Problems, Submarine Decommissioning, Submarine Safety, and Security of Naval Fuel*, Greenpeace Trip Report, Washington D. C. October 27, 1994.
- Handler, Joshua, *Submarine Safety - The Soviet/Russian Record*, Jane's Intelligence Review, London July 1992.
- Handbook from the firms subject to GRTsAS, presented before the Russian Government in 1993.
- Handbook *On implementation plan for handling of nuclear waste and spent fuel in Severodvinsk Territory*, Summer 1994.
- Handbook from the Russian Ministry of Defence, April 1994.
- International Institute for Strategic Studies, *Militærbalansen 1995/96* (The Military Balance 1995/96), Oslo 1995.
- Izvestiya*, Moscow, July 13, 1993, May 12 and June 3, 1995.
- Jane's Defence Weekly*, London, September 16 and November 4, 1995, January 3 and February 28, 1996.
- Jane's Fighting Ships 1995 - 96*, 98th edition, London 1995.
- Jane's Intelligence Review*, London, December 1993 and March 1994.
- Jane's Navy International*, London, November - December 1995.

- Klinov, Aleksey, Note, Severodvinsk 1994.
- Kommersant Daily*, Moscow June 29, 1995.
- Komsomolets Zapolyarya*, Murmansk January 19, 1991.
- Komsomolskaya Pravda*, Moscow, June 30, 1989 and June 23, 1995.
- Krasnaya Zvezda* (Red Star), Moscow, December 26, 1992, January 28 (with references to the Russian Magazine *Russkoe orushie* (Russian Weapons) which refers to the book: Kostev, Georgy (Rear Admiral), *Post-War History of the Russian Navy (1945 - 1991)*), April 15 and 29, May 27, July 13 and October 13, 1995.
- Kremlin, A. E., *Security at Nuclear Energy Installations*, Moscow.
- Kurchatov, Aleksandr, *New Chernobyls at Sea*, chronicle in the *Moscow Times*, Moscow March 2, 1996.
- Kværner Moss Technology as., *Disposal of Russian Nuclear Submarines*, a report presented to the Ministry of Foreign Affairs, Oslo January 19, 1996.
- Lee, Robin, *State of the Russian Navy Data Page*, with sub-files, available at URL: [<http://www.webcom.com/~amraam/rnav.html>], last updated January 1996.
- Lingjærde, Rolf O., *Kjernekraft Status og Utvikling 1995* (Nuclear energy, status and development 1995), Institute of Energy Technology, Kjeller November 1995.
- Morskoy sbornik*, Moscow No. 6, 1990, No. 1, 1991, Nos. 4 and 7, 1992, Nos. 3, 4, 6, 9 and 12, 1993, Nos. 4, 7 and 12, 1994, Nos. 1, 6 and 8, 1995.
- Moscow News, The Great Uranium Caper*, English edition No. 48, Moscow December 8 - 14, 1995.
- Murmansky Vestnik*, Murmansk, December 2, 1993, January 5 and 11 and March 15, 1995.
- Na strazhe Zapolyarya*, Severomorsk. April 19, 21 and 22, May 31, June 21 and 24, 1995.
- NATO, *Cross-border environmental problems emanating from defence related installations and activities*, Volume 1: Radioactive contamination, Committee on the Challenges of Modern Society, Phase 1: 1993 - 1995, Report No. 204, April 1995.
- Nezavisimaya Gazeta*, Moscow, April 22, October 25 and 31, 1995 and January, 1996.
- Nevskoye Vremya*, St. Petersburg February 22, 1996.
- Nilsen, Thomas and Bøhmer, Nils, *Sources to Radioactive Contamination in Murmansk and Arkhangelsk Counties*, Bellona report No. 1 - 1994, Oslo March 1, 1994.
- Nilsen, Thomas, *Ulykken med atomubåten K-192* (The accident on the nuclear submarine K-192 (former K-131)), Bellona Working Paper, Murmansk August 2, 1995.
- Norwegian High Command, *Atomdrevne fartøyer ved Nordflåten og avfallsproblemene* (Nuclear Powered Vessels of the Northern Fleet and Connected Disposal Problems), Note to The Ministry of the Environment, Oslo April 7, 1992.
- Nuclear Engineering International, *World Nuclear Industry Handbook 1996*, Surrey 1996.
- Office of Naval Intelligence, *Worldwide Submarine Proliferation in the Coming Decade*, 3rd edition, Washington D. C., May 1995.
- Office of Technology Assessment, *Nuclear Waste in the Arctic, an Analysis of Arctic and Other Regional Impacts from Soviet Nuclear Contamination*, Congress of the United States, Washington D. C., September 1995.
- Office of Technology Assessment, Environment Program, Summary of Workshop on *Russian Naval Spent Nuclear Fuel and Waste Management*, Congress of the United States, Washington D. C., April 1995.
- Osipenko, Leonid G., Zhiltsov, Lev M. and Mormul, Nicolay G., *Atomnaya Podvodnaya Epopeya* (The Nuclear Underwater Era), Moscow 1994.
- Papkovsky, B. N. (Minatom), *Status and Problems with Decommissioning of Marine Reactors in Russia*, lecture presented in the document: *Russian Naval Spent Nuclear Fuel and Waste Management*, Office of Technology Assessment, Washington D. C., April 1995.
- Pavlov, Aleksandr S., *Military Vessels of the Soviet Union and Russia 1945 - 1995*, 3rd edition, Yakutsk 1994.
- Perovsky, Vyacheslav A. (VNIPIET), Handbook presented before the Murmansk County Committee for Ecology and Natural Resources, Murmansk 1992.
- Perovsky, Vyacheslav A. (VNIPIET), *Possibilities for the Storing of Reactor Compartments Onshore*, St. Petersburg 1995.
- Petrov, Oleg, *Radioactive Waste and Spent Nuclear Fuel in the Navy of Russia*, Moscow - Oslo 1995.
- Polmar, Norman and Noot, Jurrien, *Submarines of the Russian and Soviet Navies, 1718 - 1990*, Naval Institute Press, Maryland 1991.
- Polyarnaya Pravda*, Murmansk,

- February 28 and September 26, 1995, January 24, 1996.
- Pravda*, Moscow July 1, 1991.
- Preston, Antony, *Dreadnought to Nuclear Submarines*, National Maritime Museum, London 1980.
- Publicity brochure from naval yard No. 35, Sevморput, 1992
- Resolution document March 1, 1995, No.15, Moscow 1995.
- Ries, Tomas and Skorve, Johnny, *Investigating Kola, A Study of Military Bases Using Satellite Photography*, The Norwegian Institute of International Affairs, Oslo 1987.
- Romanov, D. A., *The Tragedy of the Nuclear Submarine «Komsomolts»*, St. Petersburg 1995.
- The Rose Isles of the White Sea*, Severodvinsk 1992.
- Rossiyskaya Gazeta*, Moscow September 14, 1995.
- Russian Governmental Decree No. 514, Moscow July 24, 1992 (signed by J. Gaydar) and decree No. 644-47, Moscow August 31, 1992.
- Russian Presidential Decree, No. H-1344, Moscow November 8, 1992.
- Russian Presidential Decree, Moscow June 5, 1995
- Rybny Murman*, Murmansk, June 23 - 29, 1995, February 2 - 6, 1996.
- Sarkisov, A. A., *Physical Basis for the Use of Nuclear Steam Producing Installations*, Moscow.
- Severny Rabochy*, Severodvinsk, June 3 and July 17, 1993, January 27, March 3 and November 18, 1994, January 19, February 15, March 7, 23, 24 and 25 and November 20, 1995.
- Sinking Radioactive Nightmare*, SVT2 - Norra Magasinet, Luleå 1994
- Skogan, John Kristian, *Sovjetunionens Nordflåte* (The Soviet Northern Fleet) 1968 - 85, NUPI - report No. 105, Oslo 1986.
- Skogan, John Kristian, *Russland og betydningen av Kola-halvøya i historisk lys* (Russia and the importance of the Kola Peninsula seen in a historic perspective), The Norwegian Institute of International Affairs, Note No.477, Oslo October, 1992.
- Skorve, Johnny, *The Kola Satellite Image Atlas*, The Norwegian Institute of International Affairs, Oslo 1991.
- Sudoexport, *Tanker Undersea*, Moscow 1994.
- Sudoexport, *Undersea Transport Container Carrier*, Moscow 1994.
- Sudostroenie* (Ship construction), No. 9 - 1990 and No. 1 - 1991.
- The St. Petersburg Press*, February 20 - 26, 1996.
- Toppan, Andrew, *USN Submarine List*, available at URL: <http://www.wpi.edu/~elmer/>, Last updated 11/13 1995, Version 1.2.
- United States General Accounting Office, *Nuclear Safety, Concerns With Nuclear Facilities and Other Sources of Radiation in the Former Soviet Union*, Report to Senator Bob Graham, Washington D. C. November, 1995.
- UPI, *Russian nuclear sub could be an environmental time bomb*, New York February 8, 1994.
- Vårt Vern*, Oslo No. 3, 1993.
- Yablokov, Aleksey V. et al., *Facts and problems related to radioactive waste disposals in seas adjacent to the territory of the Russian Federation*, Moscow 1993.
- Yemalenikov, Aleksandr and Popov, Boris, *Atom bez grifa sekretno* (Unconfidential Atoms), IPPNW, Moscow - Berlin 1992.
- Ølgaard, P. L., *Nuclear ship accidents description and analysis*, NT-4 (2nd edition), Department of Electrophysics, Technical University of Denmark, March 1993.
- Ølgaard, P. L., *Potential risk of nuclear ships*, NT-11, Department of Electrophysics, Technical University of Denmark, July 1994.

Suggested reading

- Argumenty i fakty, *The Army in Figures*, A. Kondrasjov, no. 8, 1996.
- Bergman, R., Baklanov, A. and Segerstahl, B., *Overview of nuclear risks on the Kola Peninsula (Summary Report)*, International Institute for Applied Systems Analysis, Laxenburg, Austria, May 1996.
- Cochran, T., Arkin, W., Norris, R. and Sands, J. *Soviet Nuclear Weapons*, Nuclear Weapons Databook, volume IV, Natural Resources Defense Council, Inc., New York, 1989.
- Feshbach, M., *Russia in Transition, Ecological Disaster, Cleaning up the Hidden Legacy of the Soviet Regime*, A Twentieth century fund report, New York, 1995.
- Izvestija, *Submarine officers conducted a rocket missile launch from the north to the firing range at Arkhangelsk*, V. Litovkin, 29. August 1995.; *Baksjanskij, 3. captain, and his God prevailed against the military prosecution*, V. Litovkin, 31. January 1996.; *Who shall benefit from the AES-contamination*, A. Pasjkov, 5. March 1996.
- Komsomolets Zapoljarja, *The North Fleet has greater financial difficulties than during the war*, 24. February 1996.
- Krasnaja Zvezda, «*Pjotr Velikij*» - a new side of the Russian Fleet history. *We must hope it's not the last*, O. Potsjnjuk, 13. October 1995.; *Russias strategic nuclear naval forces go to the bottom*, N. Kalistratov, 13. January 1996.
- LeSage, L. G. and Sarkisov A. A., *Nuclear Submarine Decommissioning and Related Problems*, Proceedings of the NATO Advanced Research Workshop, Moscow, 19. - 22. June 1995.
- Moskovskaja Pravda, *Northern hostages*, D. Barinov, 5. August 1995.; *War fleet of the Soviet Union (Russia) in the years 1989 - 95*, 25 January 1996.
- Murmansk vestnik, *Rockets are business*, I. Stalinskaja, 9. June 1995.; *Strategic nuclear naval forces: realities and perspectives*, 17. January 1996.; *The North Fleet has a billion-debt*, I. Stalinskaja, 27. March 1996.; *Liquid metal*, N. Mormul, 3. April 1996.; *Catastrophe is far off, but we cannot be complacent*, V. Kondratjev, 13. April 1996.; *So yet again I leave for circumnavigation*, I. Zjeveljuk, 18. April 1996.
- Na strazje Zapoljarja, *We ensure safety*, A. Malov, 12. July 1995.; *Lacking in funds, but optimistic* V. Gundarov, 7. October 1995.; *Lacking in funds*, I. Zjeveljuk, 25. October 1995.; *The crews shall not starve*, V. Mirtsjenko, 25. October 1995.; *Watches from the supreme commander*, I. Zjeveljuk, 1. November 1995.; «*Presidential salute*», I. Zjeveljuk, 2. November 1995.; *Honour, tradition and duty*, A. Bljudenov, 4. November 1995.; *Lieutenants of the North Fleet*, V. Massalskij, 16. November 1995.; *With the Fleet remains only promising ships and units*, admiral O. Jerofejev, 23. november 1995.; *Difficulties can be surmounted if one acts*, P. Lysenko, 30. November 1995.; *Press release from the armed navy*, 6. December 1995.; *Where the rockets «sleep»*, D. Litovkin, 10. December 1995.; *Not all depends on politicians*, admiral O. Jerofejev, 16. December 1995.; *The importance of the Fleet must increase*, admiral F. Gromov, 20. December 1995.; *As before, the North Fleet is among the best*, I. Zjeveljuk, 20. December 1995.; *For the Fleet, the times of change have passed*, admiral I. Kasatonov, 21. December 1995.; «*Vepr*» is put to use, L. Teltevsckaja, 23. December 1995.; *Farewell arms!*, A. Bobretsov, 24. January 1996.; *Daily lives in the «elite»*, I. Zjeveljuk, 14. February 1996.; *War on two fronts*, V. Serga, 7. March 1996.; *On the commencement of the nationwide collection for completion of ships*, 6. April 1996.
- Nezavisimaja gazeta, *Admirals are concerned about the destiny of the Russian Fleet*, 1. March 1996.
- Nezavisimaja gazeta (enclosed: Nezavisimaja vojennoje obozrenije), *Crew deficiency in the armed forces threatens national security*, V. Mukhin and A. Ovtsjinnikov, February 1996.; *The naval component of the nuclear triad*, admiral O. Jerofejev, March 1996.
- Novaja Tambovskaja gazeta, *The navy and its friends stand united in Tambovsk*, V. Polozov, 13. October 1995.
- Office of Naval Intelligence, *Worldwide submarine challenges*, Washington D. C. February 1996.
- Pravda, N. Kalistratov, 27. December 1995.
- Pravda-5, *Lacking a powerful navy Russia is no longer Russia*, fleet admiral I. Kapitanets, 23. February 1996.

Pravda Severa, *How one bids the U-boats goodbye*, O. Khimanytsj, 2. September 1995.

Rabotsjaja tribuna, *Theft is impossible, but detonation even more so*, V. Lasjukul, 15. November 1995.

Rossijskije vesti, *Last mooring of the nuclear cruiser*, D. Litovkin, 20. April 1996.

The International Center for Technology Assessment, *The Threat of Nuclear Submarine Operations to Global Security and Environmental Safety*, (Preliminary Report), Washington D. C., 1996.

Vestnik vojennoj informatsii, *What disturbs the Russian army*, no. 10, October 1995.

Vetsjernyj Murmansk, *The admiral is puzzled*, M. Kumunzjijeva, 2. December 1995.